

**Economic and Social Council**Distr.: General
26 September 2019

Original: English

Economic Commission for Europe

Inland Transport Committee

World Forum for Harmonization of Vehicle Regulations**Working Party on Passive Safety****Sixty-sixth session**

Geneva, 10-13 December 2019

Item 2 of the provisional agenda

UN Global Technical Regulation No. 7 (Head restraints)**Proposal for Amendment 1 of Phase 2 of UN Global
Technical Regulation No. 7 (Head restraints)****Submitted by the expert from the European Association of Automotive
Suppliers ***

The text reproduced below was prepared by the expert from the European Association of Automotive Suppliers (CLEPA) to amend the proposal of Amendment 1 (ECE/TRANS/WP.29/GRSP/2019/5, amended by GRSP-65-24) to Global Technical Regulation N° 7. Head Restraints proposed by Japan and the Informal Working Group on Phase 2 of Head Restraints. This document is based on ECE/TRANS/WP.29/GRSP/2019/10 and supersedes it. The modifications to the existing text of the UN Global Technical Regulation No. 7 (ECE/TRANS/180/Add.7) are marked in bold for new or strikethrough for deleted characters.

* In accordance with the programme of work of the Inland Transport Committee for 2018–2019 (ECE/TRANS/274, para. 123 and ECE/TRANS/2018/21/Add.1, Cluster 3.1), the World Forum will develop, harmonize and update UN regulations to enhance the performance of vehicles. The present document is submitted in conformity with that mandate.



I. Proposal

Paragraph 5.4.4.5., amend to read:

"5.4.4.5. The **presence of a non-use position of a** head restraint shall be marked with a label in the form of a pictogram which may include explanatory text. The label shall either provide an indication when the head restraint is in a non-use position or provide information to enable an occupant to determine whether the head restraint is in a non-use position. The label shall be durably affixed and located such that it is clearly visible by an occupant when entering the vehicle to the designated seating position. **The number of labels is not requested to exceed the number of head restraints with non-use positions.** Examples of possible designs of pictograms are shown in Figure 1.

..."

Annex 2, paragraph 2.1., amend to read:

"2.1. The seat shall be adjusted such that its H-point coincides with the R-point; if the seat back is adjustable, it is set at the design seat back angle; both these adjustments shall be in accordance with the requirements of paragraph 2.1. of Annex 1.

The head restraint shall be adjusted to its highest and most rearward position relative to the seat back."

Annex 3, paragraph 2.3., amend to read:

"2.3. The area of measurement is anywhere between two vertical longitudinal planes passing at 85 mm on either side of the torso line and above ~~the top of the seat back~~ **a height of 540 mm."**

Annex 3, paragraph 2.5., amend to read:

"2.5. Determine the gap dimension by measuring the straight line distance between the inner edges of the two furthest contact points, as shown in Figures 3-1, ~~and 3-2 and 3-3.~~"

Annex 3, insert a new Figure 3-3, to read:

"Figure 3-3

Portion of gap above 540mm.

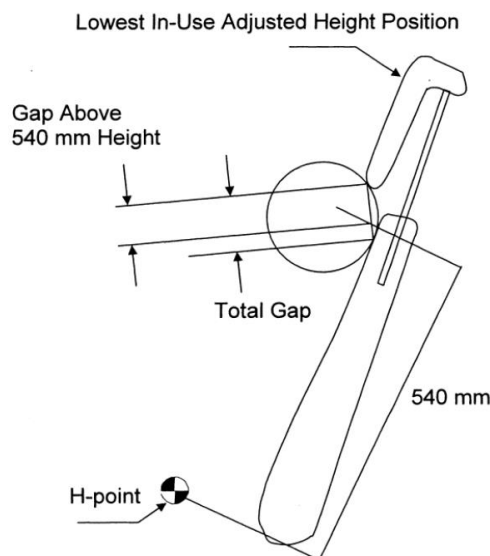

"

Annex 3, paragraph 3.3., amend to read:

"3.3. The gap between the bottom of the head restraint and the top of the seat is measured as the perpendicular distance between two parallel planes, described as follows (see Figure 3-34):"

Annex 3, Figure 3-3 (former), renumber as Figure 3-4

Annex 4, shall be deleted

Annexes 5 to 7 (former), renumber as Annexes 4 to 6

Annex 8 (former), renumber as Annex 7 and insert a new paragraph 2.10. to read:

"2.10. Alternatively, when the manufacturer demonstrates that the difference of the reference positions of the cylinder measured in paragraphs 2.3. and 2.6. of this Annex is smaller than the value required by paragraph 5.2.2. of the Regulation, then the test result will also comply to paragraph 5.2.2. of the Regulation. In this case measurements of 2.4. and 2.7. of Annex 7 do not need to be recorded."

Annexes 9 to 13 (former), renumber as Annexes 8 to 12

II. Justification

1. This document clarifies the way to apply and to understand GTR7, phase 2 static alternative provisions which have been detected as not being fully clear. It also aligns the area where the gap is measured to actual practice in UN Regulation No. 17 and Federal Motor Vehicle Safety Standard 202 which considers only gaps over a height of 540mm.

2. The new paragraph 2.10. to Annex 7 "Height Retention Test", aims at facilitating testing by laboratories, which can more easily measure the displacement on the top of the head restraint. As the displacement of the head restraint on the top of the head restraint is greater than the bottom of the head restraint, any head restraint fulfilling the displacement requirement of 25 mm already on the top of the head restraint would be considered also compliant with the displacement requirement of the height retention test.