

I. Proposal for supplement 7 to the 03 series of amendments to UN Regulation No.51 (Noise of M and N categories of vehicles)

Annex 3, paragraph 3.2.5.3.1.2 amend to read:

"3.2.5.3.1.2 For vehicles having an exhaust provided with outlets more than 0.3 m apart **or more than one silencer**, one set of measurements shall be made for each outlet. ~~The highest levels shall be recorded.~~

Annex 3, paragraph 3.2.5.3.1.3 amend to read:

"3.2.5.3.1.3 ~~In the case of an exhaust provided with two or more outlets spaced less than 0.3 m apart and which are connected to the same silencer; the microphone position is related to the outlet nearest to one extreme edge of the vehicle or, when such outlet does not exist, to the outlet which is highest above the ground.~~

If a vehicle has two or more exhaust outlets spaced less than or equal to 0.3 m apart and connected to a single silencer, only one measurement shall be made. The microphone shall be located relative to the outlet furthest away from the vehicle longitudinal centerline, or when such outlet does not exist, to the outlet, which is highest above the ground.

Annex 3, paragraph 3.2.5.3.1.5 amend to read:

"3.2.5.3.1.5. ~~For exhaust outlets located under the vehicle body, the microphone shall be located a minimum of 0.2 m from the nearest part of the vehicle, at a point closest to, but never less than 0.5 m from the exhaust pipe reference point, and at a height of 0.2 m above the ground, and not in line with the exhaust flow. The angularity in requirement in paragraph 3.2.5.3.1.2 may not be met in some cases.~~

For vehicles, where the reference point of the exhaust pipe is not accessible, or located under the vehicle body, as shown in Figure 3b and 3c in Annex 3, because of the presence of obstacles which form part of the vehicle (e.g. spare wheel, fuel tank, battery compartment), the microphone shall be located at least 0.2 m from the nearest obstacle, including the vehicle body, and shall not be located under the vehicle. Its axis of maximum sensitivity shall face the exhaust outlet from the position least concealed by the above mentioned obstacles. In case the distance from the exhaust outlet to the other side of the vehicle is larger than 0.2 m (Figures 3c and 3d in Annex 3), the following distances of d_1 and d_2 shall be chosen:

Case 1:

d_1 shall be equal to 0.5 m and the distance from the side (outer border of the vehicle) shall be at least 0.2 m.

d_2 shall be equal to 0.5 m and the distance from the side (outer border of the vehicle) shall be at least 0.2 m.

Case 2 (if Case 1 is not fulfilled):

d_1 shall be at least 0.5 m and the distance from the side (outer border of the vehicle) shall be equal to 0.2 m.

d_2 shall be at least 0.5 m and the distance from the side (outer border of the vehicle) shall be equal to 0.2 m.

When several positions are possible, as shown in Figure 3c, the microphone position giving the lowest value of d_1 or d_2 shall be used.

Annex 3 – Appendix, amend to read:

Figure 3a

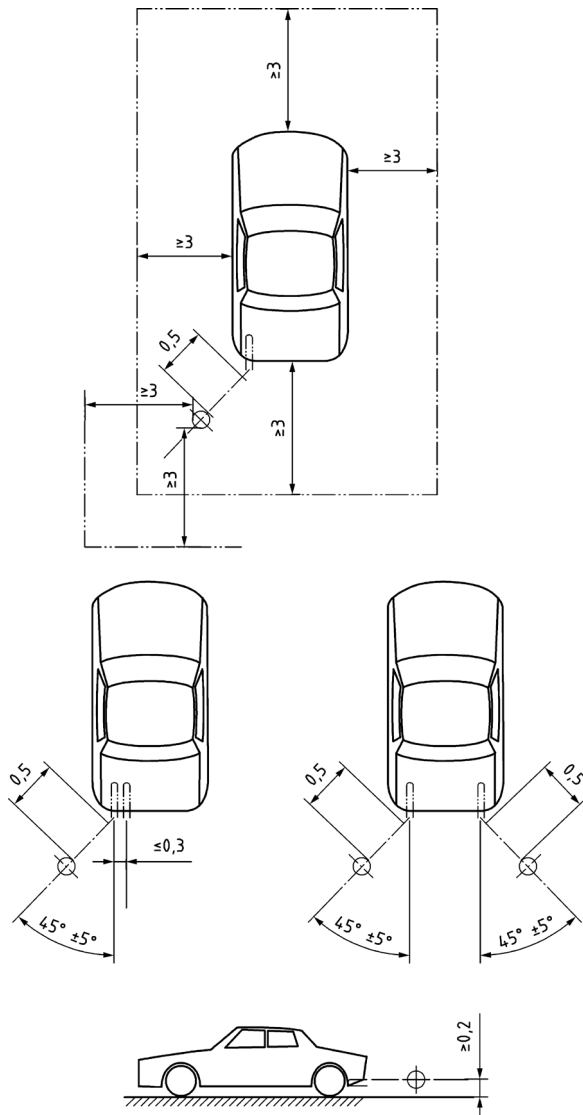

Figure 3b

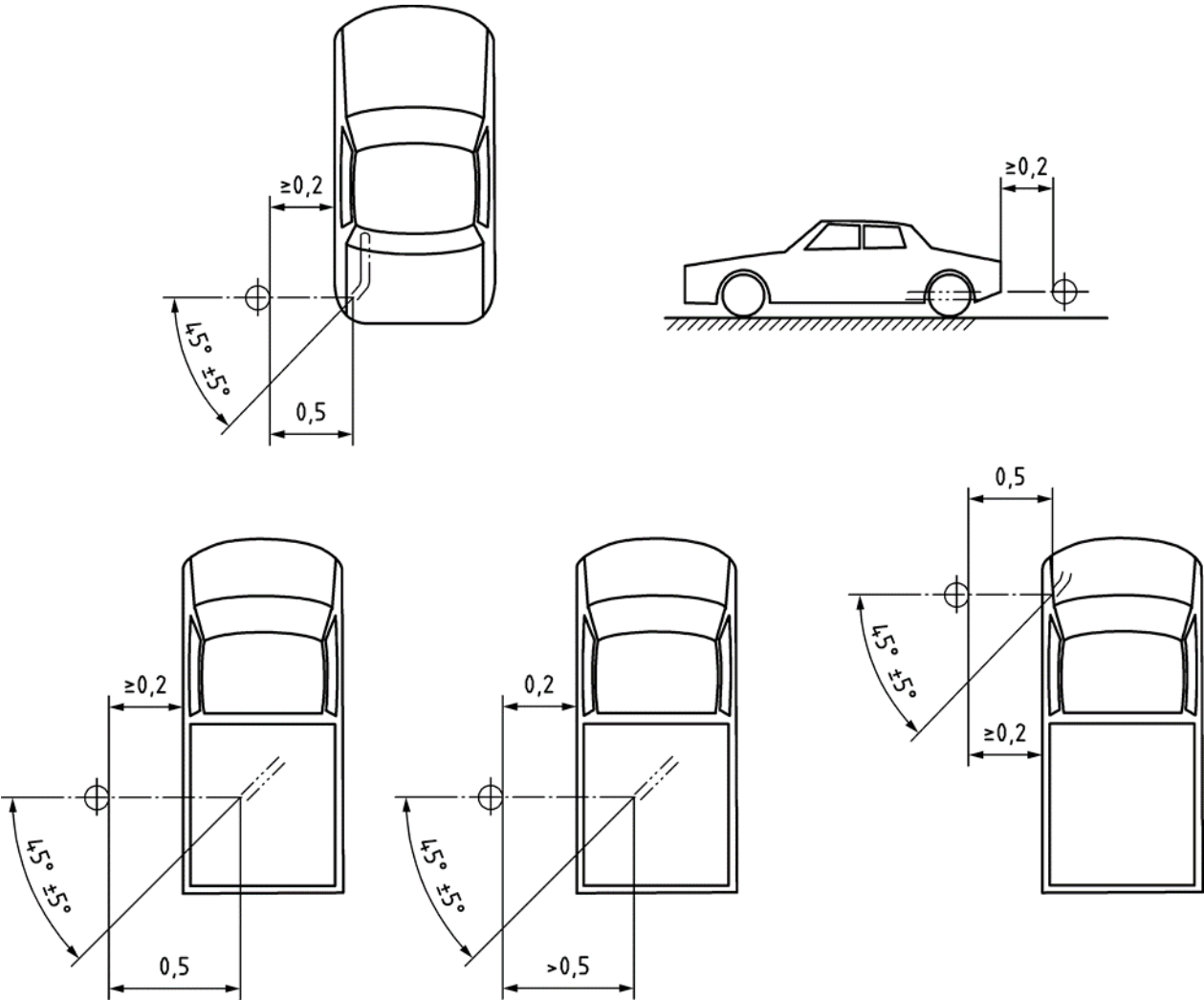

Figure 3c

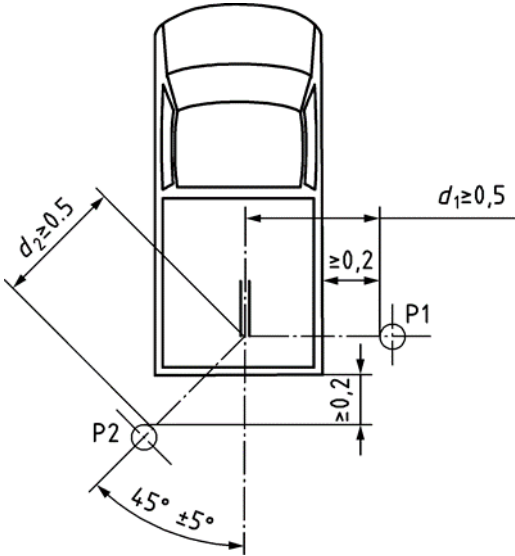
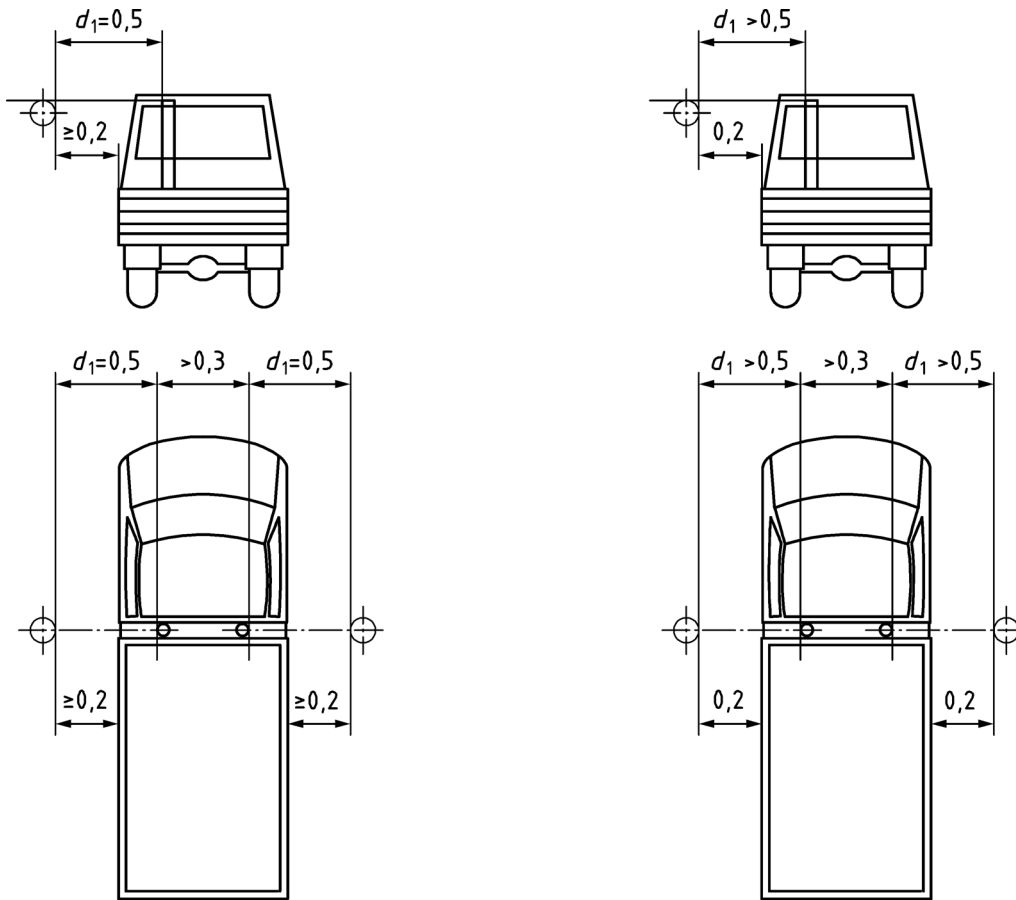

Figure 3d



II. Justification

Annex 3, paragraphs 3.2.5.3.1.2, 3.2.5.3.1.3 and 3.2.5.3.1.5.

All paragraphs have been updated according to the latest revision of ISO 5130:2019, to ensure a defined location of the microphone position, due to various exhaust outlet configurations.

Annex 3 – Appendix.

Figures 3b to 3d have been updated in according to the latest revision of ISO 5130:2019.