



**Economic and Social Council**

Distr.: General  
9 June 2016

Original: English

---

**Economic Commission for Europe**

Inland Transport Committee

**World Forum for Harmonization of Vehicle Regulations**

**Working Party on Passive Safety**

**Fifty-ninth session**  
Geneva, 9-13 May 2016

**Report of the Working Party on Passive Safety  
on its fifty-ninth session**

**Addendum 1**

## Draft 02 series of amendments to Regulation No. 129

Submitted by the Chair of GRSP \*

### Note by the secretariat

The text reproduced below represents the consolidated 02 series of amendments to UN Regulation No. 129, including all the amendments to ECE/TRANS/WP.29/GRSP/2016/4, adopted by GRSP at its fifty-ninth session (see para. 44 of the report). The modifications to the current text of UN Regulation No. 129 are marked in bold for new characters.

*Table of content*, insert a new Annexe 23:

*Paragraph 1.*, amend to read:

- "1. Scope
- This Regulation applies (in its Phases 1 and 2) to the following child restraint system for child occupants of power driven vehicles:
- (a) Integral Universal ISOFIX Enhanced Child Restraint Systems (i-Size);
  - (b) Integral Specific vehicle ISOFIX Enhanced Child Restraint Systems;
  - (c) **non-integral Universal Enhanced Child Restraint Systems (i-Size booster seat);**
  - (d) **non integral specific vehicle enhanced child restraint systems (specific vehicle booster seat)."**

*Insert new paragraph 2.3.*, to read:

**"2.3. "Integral Universal" and "Non-Integral Universal"**

*Paragraph 2.3.(former)*, renumber as paragraph 2.3.1.

*Insert new paragraph 2.3.2.*, to read:

**"2.3.2. " i-Size booster seat" (Non-Integral Universal Enhanced Child Restraint System) is a category of Enhanced Child Restraint Systems with integrated backrest and stowable ISOFIX connectors if any, primarily designed for use in all i-Size seating positions of a vehicle."**

*Insert new paragraph 2.7.2.*, to read:

**"2.7.2. "Specific vehicle booster seat" is a category of Non-Integral Enhanced Child Restraint System, with integrated backrest, for use in specific vehicle types, with vehicle anchorages approved according to Regulation No. 14. This category includes "Built-in booster seats."**

*Insert new paragraph 2.17.2.*, to read:

---

\* In accordance with the programme of work of the Inland Transport Committee for 2016–2017 (ECE/TRANS/254, para. 159 and ECE/TRANS/2016/28/Add.1, cluster 3.1), the World Forum will develop, harmonize and update Regulations in order to enhance the performance of vehicles. The present document is submitted in conformity with that mandate.

"2.17.2. **" i-Size booster seat fixture" means a fixture, of the dimensions given in figure 1 of Annex 17, Appendix 5 of Regulation No. 16 and used by an Enhanced Child Restraint System manufacturer to determine the appropriate dimensions of a i-Size booster seat and its compatibility with most vehicle seating positions and, in particular, those which have been assessed without ISOFIX attachments<sup>1</sup>, according to Regulation No. 16 as being compatible with such a category of an Enhanced Child Restraint System."**

*Paragraph 2.51., amend to read:*

"2.51. **"ECRS position"**

"2.51.1. **"ISOFIX position"** means a location as defined in paragraph 2.17. of Regulation No. 14.

"2.51.2. **" i-Size seating position"** means a seating position, declared by the vehicle manufacturer, which is designed to accommodate any i-Size Enhanced Child Restraint System, as defined in this Regulation."

*Insert new paragraphs 2.56. to 2.56.2., to read:*

"2.56. **"Lock-off device"** locks and prevents movement of one section of the webbing of an adult safety-belt relative to another section of the webbing of the same belt. Such devices may act upon either the diagonal or the lap sections or secure together both lap and diagonal sections of the adult belt. The term covers the following classes:

2.56.1. **"Class A device"** prevents the child from pulling the webbing of the retractor through to the lap part of the belt, when the adult belt is used to restrain the child directly.

2.56.2. **"Class B device"** (to be used in phase III) allows the retention of an applied tension in the lap part of an adult safety-belt, when the adult belt is used to restrain the Enhanced Child Restraint System. The device intends to prevent the webbing from slipping from the retractor through the device, which would release the tension and place the restraint in a non-optimal position."

*Paragraph 2.56.(former), renumber as paragraph 2.57.*

*Paragraph 3.2.2., amend to read:*

"3.2.2. The applicant shall indicate the kind of application:

- (a) Application for an i-Size Enhanced Child Restraint Systems; or
- (b) Application for a specific vehicle ISOFIX; **or**
- (c) **Application for a i-Size booster seat Enhanced Child Restraint System; or**
- (d) **Application for a specific vehicle booster seat Enhanced Child Restraint System;**
- (e) **Or any combination of (a), (b), (c) and (d) as long as they fulfil paragraphs 5.4.2.2. and 6.1.3.3."**

<sup>1</sup> Detail B describes the standard dimensions without ISOFIX attachments. Figure 1 gives the dimensions for optional jstowable ISOFIX attachments.

Paragraph 4.3., amend to read:

- "4.3. The following information shall be clearly indicated on the product:
- (a) The orientation of the Enhanced Child Restraint System relative to the vehicle;
  - (b) The size range(s) of the Enhanced Child Restraint System in centimetres;
  - (c) The maximum occupant mass allowed for the Integral Enhanced Child Restraint System in kilograms.

**If the Enhanced Child Restraint System is to be used in combination with an adult safety-belt, the correct webbing path shall be clearly indicated by means of a drawing permanently attached to the Enhanced Child Restraint System. If the restraint is held in place by the adult safety-belt, the webbing paths shall be clearly marked on the product by colour coding. The colours used for the path of the safety-belt when the device is installed in the forward-facing position shall be red and when installed in the rearward-facing shall be blue. The same colours shall also be used on the labels on the device that illustrate the methods of use.**

**There shall be a clear differentiation between the intended paths for the lap section and the diagonal section of the safety belt. Indication such as colour coding, words, shapes, etc. shall distinguish between sections of the safety belt.**

The marking defined in this paragraph shall be visible with the Enhanced Child Restraint System in the vehicle, with the child in the Enhanced Child Restraint System."

Insert new paragraphs 4.7. to 4.7.2., to read:

- "4.7. **Marking for non-integral ECRS**
- 4.7.1. ***i*-Size booster seat Enhanced Child Restraint Systems shall have a permanently attached label with the following information visible to the person installing the Enhanced Child Restraint System in the car:**

***i*-Size booster seat** 

- 4.7.2. ***Specific vehicle booster seat* Enhanced Child Restraint System (except built-in) shall have a permanently attached label with the following information visible to the person installing the Enhanced Child Restraint System in the car:**

***Specific vehicle booster seat*** 

Paragraphs 4.7.(former), renumber as paragraph 4.8.

Paragraphs 5.4.2. to 5.4.2.2., amend to read:

- "5.4.2. The following additional symbols:
- 5.4.2.1. The words "i-Size universal ISOFIX", or "***i*-Size booster seat**", or "specific vehicle ISOFIX" or "**specific vehicle booster seat**" depending on the category of Enhanced Child Restraint System;

- 5.4.2.2. The size range for which the Enhanced Child Restraint System has been designed;
- 5.4.2.3. In case the ECRS is equipped with a module, the size range is not on the approval mark but on the module mark."

*Paragraph 5.4.2.3.(former)*, renumber as paragraph 5.4.2.4.

*Paragraph 6.1.1.*, amend to read:

- "6.1.1. Enhanced Child Restraint Systems in the i-Size category are **primarily designed** for use in i-Size seating positions, when the Enhanced Child Restraint Systems are fitted in conformity with the vehicle manufacturer's instructions.

**The instructions of a forward facing i-Size integral ECRS that utilise a top tether as the anti-rotation device may declare that the ECRS can be used in any ISOFIX seating positions.**

**The instructions of other i-Size integral ECRS may declare that the ECRS can be used in ISOFIX seating positions specified in a car fitting list.**

**Enhanced Child Restraint Systems in the i-Size booster seat category are primarily designed for use in all i-Size seating positions.**

Enhanced Child Restraint Systems in the specific vehicle ISOFIX category are for use in all ISOFIX positions and also in the luggage area, if the restraints are fitted in conformity with the vehicle manufacturer's instructions.

**Enhanced Child Restraint Systems in the specific vehicle booster seat category are to be used according to manufacturer's instructions."**

*Insert new paragraphs 6.1.3. to 6.1.3.5.*, to read:

- "6.1.3. According to the category as defined by Table 2, the Non-Integral Enhanced Child Restraint System and the child shall be secured in a vehicle seating position:
- 6.1.3.1. For the i-Size booster seat category, by means of the adult safety seat belt and possibly with optional ISOFIX attachments, if these are stowable (see Regulation No. 16, Annex 17, Appendix 5, Figure 1, Detail B).
- 6.1.3.2. For the specific vehicle booster seat category, by means of the adult safety seat belt and possibly with attachments designed by the manufacturer of the Enhanced Child Restraint System, secured to anchorages as designed by the vehicle manufacturer. Only ISOFIX attachments shall be used in conjunction with ISOFIX anchorage system.

**Table 2**  
**Possible configurations of Non-Integral Enhanced Child Restraint Systems for type approval**

	<i>Orientation</i>	<i>Category</i>	
<b>Non-Integral</b>		<b>i-Size booster seat</b>	<b>Specific vehicle booster seat (Built-in included)</b>

	<i>Orientation</i>	<i>Category</i>	
	<b>Forward Facing</b>	<b>A</b>	<b>A</b>
	<b>Rearward Facing</b>	<b>NA</b>	<b>NA</b>

A: Applicable

NA: Non-Applicable

**6.1.3.3.** For non-integral Enhanced Child Restraint Systems, type approval shall not be granted for a stature below 100 cm. Non-integral Enhanced Child Restraint Systems shall not be declared for use below a stature of 100 cm.

Non integral ECRS shall not be approved with an upper stature limit of 105 cm or below.

Booster seats shall insure lateral protection of the child as described in paragraph 7.1.3.1.3. up to a stature of 135 cm.

ECRS shall accommodate an uninterrupted range of child statures.

*Note:* For example, a booster seat shall not accommodate children of 100 cm to 130 cm and then children of 140 cm to 150 cm with an "interruption".

**6.1.3.4.** Enhanced Child Restraint Systems of the i-Size booster seat category shall have a main load-bearing contact point, between the Enhanced Child Restraint System and the adult safety belt. This point shall not be less than 150 mm from the Cr axis when measured with the Enhanced Child Restraint System on the dynamic test bench installed in accordance with paragraph 7.1.3.5.2.2. of this Regulation, without a dummy. This shall apply to all adjustment configurations and variable belt paths.

**6.1.3.5.** The adult seat belt required to secure a i-Size booster seat on the dynamic test bench is defined in Annex 23 to this Regulation. The Enhanced Child Restraint System shall be secured onto the test bench using the appropriate standard seat belt described in Annex 23 using a preload tension of 50N +/- 5N. The dummy shall not be installed unless the design of the restraint is such that the installation of a dummy would increase the amount of belt used. With the Enhanced Child Restraint System in the installed position, there shall be no additional tension in the belt, apart from that exerted by the standard retractor (4 ± 3 N), where fitted. Where the retractor belt is used, this condition shall be met with at least 150 mm of belt remaining on the spool.

A clamping mechanism used according to paragraph 7.1.3.5.2.2. shall not have any influence on the belt path."

*Insert new paragraph 6.2.1.6., to read:*

**"6.2.1.6.** For i-Size or specific vehicle booster seats, the lap portion of the adult seat belt shall be positively guided to ensure that the loads transmitted by the adult lap belt are transmitted through the pelvis. The shoulder portion of the adult safety belt shall be positively guided to ensure that the child torso and neck do not escape."

Paragraphs 6.2.1.6.(former) to 6.2.1.9.(former), renumber as paragraphs 6.2.1.7. to 6.2.1.10.

Paragraph 6.3.2.1., amend to read:

"6.3.2.1. Internal geometric characteristics

The Technical Service conducting the approval tests shall verify that the internal dimensions of the Child Restraint System conform to the requirements of Annex 18. The minimum dimensions for shoulder breadth, hip breadth and sitting height shall be fulfilled **simultaneously for any stature within the size range declared by the manufacturer. Integral Enhanced Child Restraint System shall also fulfil** the minimum and maximum dimensions of shoulder height, **for any stature within the size range declared by the manufacturer."**

Paragraph 6.3.2.2., amend to read:

"6.3.2.2. External dimensions

**The Technical Service conducting the approval tests shall verify that the external dimensions of the Enhanced Child Restraint System conform to the requirements of paragraphs 6.3.2.2.1. and 6.3.2.2.2., as applicable.**

**6.3.2.2.1. Integral Class Enhanced Child Restraint Systems**

**The maximum external dimensions for the width, height and depth of the Enhanced Child Restraint System and the locations of the ISOFIX anchorages system, with which its attachments shall engage, shall be defined by the ISOFIX vehicle seat fixture as defined in paragraph 2.17.1. of this Regulation.**

- (a) **i-Size Forward facing Enhanced Child Restraint Systems shall fit within the ISO/F2x size envelope for a reduced-height forward-facing toddler CRS;**
- (b) **i-Size Rearward facing Enhanced Child Restraint Systems shall fit within the ISO/R2 size envelope for a reduced-size rearward-facing toddler CRS;**
- (c) **Specific vehicle ISOFIX Enhanced Child Restraint Systems shall fit:**
  - (i) **in vehicle(s) specified in a list; or**
  - (ii) **at least in one of the ISO (R1, R2, R3, F2, F2X, F3, L1, L2) size envelopes as described in Annex 17, Appendix 2 of Regulation No. 16.**

**When conducting this assessment, the Integral Enhanced Child Restraint System shall be adjusted to the largest size of its declared stature range (height, depth and width dimensions as defined in Annex 18). If the Enhanced Child Restraint System is capable of being adjusted to different positions of seat surface inclination, the fitting assessment shall be done in at least one position. If other positions of inclination are outside the limits of the applicable size envelope, the user manual shall indicate that the child restraint may not fit in all approved vehicles when used in one of these positions.**

**i-Size booster seats shall be adjusted to accommodate children of 135 cm stature (height, depth and width dimensions as defined in Annex 18) or**

to the largest size of its declared stature range in case the upper limit is below 135 cm. In this case, it must fit within each of its declared Vehicle Seat Fixtures in at least one adjustable position. The Enhanced Child Restraint System may be adjusted to other inclined positions (less or more reclined) that are outside the Vehicle Seat Fixture's height; in this case, the child restraint manufacturer's user manual shall clearly indicate that when used in one of these configurations, the Enhanced Child Restraint System may not fit in all vehicles approved for a Universal fixture."

**"6.3.2.2.2. Non-Integral Class Enhanced Child Restraint Systems**

The maximum external dimensions for the width, height and depth of the Enhanced Child Restraint System and the locations of the ISOFIX anchorages system if any, with which its attachments shall engage, shall be defined by the i-Size booster seat fixture as defined in paragraph 2.17.2. of this Regulation.

- (a) i-Size booster seat Enhanced Child Restraint Systems shall fit within the ISO/B2 size envelope;
- (b) Specific vehicle booster seat Enhanced Child Restraint Systems shall fit:
  - (i) in vehicle(s) specified in a list; or
  - (ii) at least in one of ISO/B2 –ISO/B3 size envelope as described in Annex 17, Appendix 2 of regulation No. 16.

When conducting this assessment, the non-integral Enhanced Child Restraint System shall be adjusted to accommodate children of 135 cm stature (height, depth and width dimensions as defined in Annex 18) or to the largest size of its declared stature range if the upper limit is below 135 cm. If the Non-integral Enhanced Child Restraint System is capable of being adjusted to different positions of seat surface inclination, the fitting assessment shall be done in at least one position. If other positions of inclination are outside the limits of the applicable size envelope, the user manual shall indicate that the child restraint may not fit in all approved vehicles when used in one of these positions. If the Non-integral Enhanced Child Restraint System has a declared stature range above 135 cm, and if it is necessary to adjust the child restraint outside the limits of the applicable size envelope for such adjustments (height, depth and width dimensions), the user manual shall indicate that the child restraint may not fit in all approved vehicles when used in one of these positions."

*Paragraph 6.6.3.1., amend to read:*

- 6.6.3.1. The Enhanced Child Restraint System shall be tested as prescribed in paragraph 7.1.2. of this Regulation; at no point during the whole test shall the manikin be fully ejected from the device, in addition when the test bench is in the upside down position the manikin's head shall not move more than 300 mm from its original position in a vertical direction relative to the test bench, **once the applied load has been removed.**

*Paragraph 6.6.4.1.3., amend to read:*

- "6.6.4.1.3. The dynamic test shall be performed on Child Restraint Systems which have not previously been under load. **The Enhanced Child Restraint System of**



the i-Size booster seat category shall be tested on the test bench described in Annex 6, and in conformity with paragraph 7.1.3.1. below."

Insert new paragraph 6.6.4.1.7., to read:

"6.6.4.1.7. In the case of non-integral Enhanced Child Restraint System making use of ISOFIX attachments, the dynamic test shall be carried out as follows:

6.6.4.1.7.1. With the ISOFIX attachments in use, and

6.6.4.1.7.2. Without the ISOFIX attachments in use."

Paragraph 6.6.4.3.1., the table amend to read:

"

Criterion	Abbreviation	Unit	Q0	Q1	Q1,5	Q3	Q6	Q10	
Head performance criterion (only in case of contact during in-vehicle testing)	HPC* (15)		600	600	600	800	800	<b>800</b>	
Head acceleration 3 ms	A head Cum3 ms ***	g	75	75	75	80	80	<b>80</b>	
Upper neck tension Force	Fz	N	For monitoring purpose only**						
Upper neck flexion moment	My	Nm	For monitoring purpose only**						
Chest acceleration 3 ms	A chest Cum 3 ms ***	g	55	55	55	55	55	<b>55</b>	
Chest deflection	TBC	mm	NA	For monitoring purpose only**					
Abdominal pressure	P	Bar	NA	NA	1.2	1.0	1.0	1.2	

\* HPC: see Annex 17.

\*\* To be reviewed within 3 years following entry into force of the series 01 of this Regulation.

\*\*\* Cum 3ms means cumulative 3ms value.

Paragraph 6.6.4.5.2., the table amend to read:

"

Criterion	Abbreviation	Unit	Q0	Q1	Q1,5	Q3	Q6	Q10	
Head performance criterion	HPC (15)		600	600	600	800	800	<b>For monitoring purpose only</b>	
Head acceleration 3 ms	A head Cum 3 ms**	g	75	75	75	80	80		
Upper neck tension force	Fz	N	For monitoring purpose only*						
Upper neck flexion moment	Mx	Nm	For monitoring purpose only*						

\* To be reviewed within 3 years following entry into force of this Regulation.

\*\* Cum 3ms means cumulative 3ms value"

Paragraph 6.6.4.1.1., amend to read:

"6.6.4.1.1. Forward facing Enhanced Child Restraint Systems

Head excursion: No part of the head of the dummy shall pass beyond the planes BA, DA and DE as defined in Figure 1 below. This shall be judged up to 300 ms or the moment that the dummy has come to a definitive standstill whatever occurs first. **Except for booster seats when testing using Q10 dummy where:**

- (a) **the value in relation to the DA plane is 840 mm; and**
- (b) **the value in relation to the BA plane is 550 mm; and**
- (c) **the rebound phase is not considered for the assessment of the plane DA and DE."**

*Paragraph 6.6.4.5.1., amend to read:*

"6.6.4.5.1. Main injury assessment criterion — Head containment

...

- (b) Head shall not exceed ... Appendix 3, Figure 1. **This criteria is for monitoring purpose only for tests with a Q10 dummy."**

*Paragraph 7.1.2.3., amend to read:*

"7.1.2.3. At this static inverted position a mass equivalent to 4 times that of the dummy, **with a tolerance of -0/+5 per cent with reference to dummies nominal masses as in Annex 8**, shall be applied vertically downwards in a plane perpendicular to the axis of rotation in addition to the dummy utilizing the load application device described in Annex 21. The load shall be applied in a gradual controlled manner at a rate not exceeding gravitational acceleration or 400 mm/min. Maintain the prescribed maximum load for a duration of 30 -0/+5 seconds."

*Paragraph 7.1.3., amend to read:*

"7.1.3. Dynamic testing for frontal, rear and lateral impact:

- (a) Frontal impact test shall be performed on i-Size (Integral Universal ISOFIX Enhanced Child Restraint Systems), Specific vehicle ISOFIX Enhanced Child Restraint Systems **and to non-integral Enhanced Child Restraint Systems i-Size booster seats and specific vehicle booster seats;**
- (b) Rear impact test shall be performed on i-Size and Specific Vehicle ISOFIX Rearward and Lateral facing Enhanced Child Restraint Systems;
- (c) Lateral impact test are performed only on the test bench for i-Size Integral Universal ISOFIX Enhanced Child Restraint Systems, Specific vehicle ISOFIX **and for non-integral Enhanced Child Restraint Systems i-Size booster seats and specific vehicle booster seats;**

..."

*Paragraph 7.1.3.1.1.5.1., amend to read:*

"7.1.3.1.1.5.1. Deceleration test device:

The deceleration of the trolley shall be achieved by using the apparatus prescribed in Annex 6 to this Regulation or any other device giving equivalent results. This apparatus shall be capable of the performance specified in paragraph 7.1.3.4. and hereafter specified:

**For frontal impact, the trolley shall be so propelled that, at the beginning of the test, its velocity is  $50 + 0/-2$  km/h and its acceleration curve is within the hatched area of the graph in Annex 7, Appendix 1.**

**For rear impact, the trolley shall be so propelled that, at the beginning of the test, its velocity is  $30 +2/-0$  km/h and its acceleration curve is within the hatched area of the graph in Annex 7, Appendix 2.**

**In addition to fulfilling the above requirements, the Technical Service shall use a mass of trolley (equipped with its seat), as specified in paragraph 1. of Annex 6, greater than 380 kg.**

**However, if the tests above were performed at a higher speed and/or the acceleration curve has exceeded the upper level of the hatched area and the child restraint meets the requirements, the test shall be considered satisfactory.**

**It is however permitted the deceleration curve exceeds the lower boundaries of the performance requirements but for a cumulative period less than 3 ms time;"**

*Paragraphs 7.1.3.5.2. and 7.1.3.5.2.1., amend to read:*

- "7.1.3.5.2. Installation for frontal, rear and lateral impacts.
- 7.1.3.5.2.1. Installation of Integral Universal ISOFIX Enhanced Child Restraint Systems (i-Size), or Integral Specific vehicle ISOFIX Enhanced Child Restraint Systems on the test bench.

The unoccupied ISOFIX Enhanced Child Restraint System shall be attached to the ISOFIX anchorage system.

Securing the ISOFIX attachments to the ISOFIX lower anchorages shall be permitted to draw the unoccupied Enhanced Child Restraint System towards those anchorages.

An additional force of  $135 +/- 15$ N shall be applied in a plane parallel to the surface of the test seat cushion. The force shall be applied along the centre line of the Enhanced Child Restraint System and at a height no more than 100 mm above the cushion.

If present, the top tether shall be adjusted to achieve a tension load of  $50 +/- 5$ N. Alternatively, and if present, the support-leg shall be adjusted according to the Enhanced Child Restraint System manufacturer's instructions.

The Enhanced Child Restraint System centre line shall be aligned with the centre line of the test bench.

The dummy shall be placed in the Enhanced Child Restraint System separate from the seat-back of the chair by a flexible spacer. The spacer shall be 2.5 cm thick and 6 cm wide. It shall have length equal to the shoulder height less the thigh height, both in the sitting position and relevant to the dummy size being tested. The resulting height of the spacer is listed in the table below for the different dummy sizes. The board should follow as closely as possible the curvature of the chair and its lower end should be at the height of the dummy's hip joint.

	Q0	Q1	Q1.5	Q3	Q6	Q10 (design targets)
	Dimensions in mm					
Height of spacer device for positioning of dummy	<b>173 ± 2</b>	229 ± 2	237 ± 2	250 ± 2	270 ± 2	359 ± 2

Adjust the ECRS belt in accordance with the manufacturer's instructions, but to a tension of  $250 \pm 25$  N above the adjuster force, with a deflection angle of the strap at the adjuster of  $45 \pm 5^\circ$ , or alternatively, the angle prescribed by the manufacturer.

The spacer shall then be removed and the dummy pushed towards to the seat back. Distribute the slack evenly throughout the harness.

The longitudinal plane passing through the centre line of the dummy shall be set midway between the two lower ECRS belt anchorages, however note shall also be taken of paragraph 7.1.3.2.1.3. above.

**7.1.3.5.2.2. Installation of a non-integral Enhanced Child Restraint Systems i-Size booster seat or specific to vehicle booster seat on the test bench.**

The unoccupied booster seat shall be placed on the test bench.

If present and tested, securing the ISOFIX attachments to the ISOFIX lower anchorages shall be permitted to draw the unoccupied Enhanced Child Restraint System towards these anchorages. An additional force of  $135 \pm 15$  N shall be applied in a plane parallel to the surface of the test bench seat cushion. The force shall be applied along the centre line of the Enhanced Child Restraint System and at a height of no more than 100 mm above the test bench seat cushion.

The dummy shall be placed in the Enhanced Child Restraint System.

**Figure 1**  
**Load cell positions**

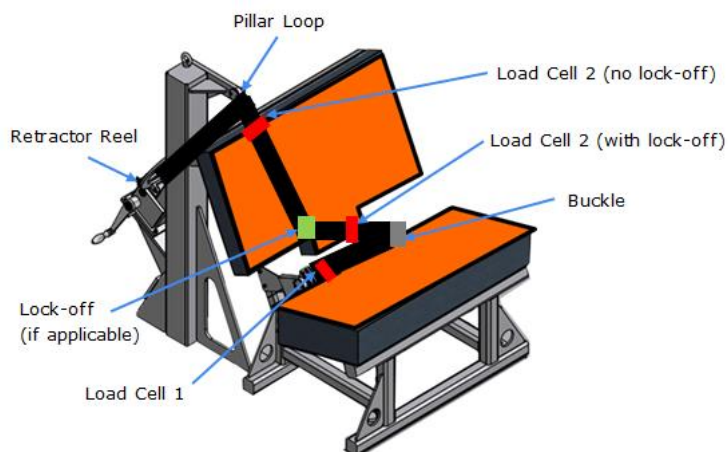

Fit load cell 1 to the outboard position as shown Figure 1. Install the Enhanced Child Restraint System in the correct position. If a lock-off device is fitted to the Enhanced Child Restraint System and acts upon

the diagonal belt, place load cell 2 at a convenient position behind the Enhanced Child Restraint System between the lock-off device and the buckle as shown above. If no lock-off device is fitted or if the lock-off device is fitted at the buckle, position the load cell at a convenient position between the pillar loop and the Enhanced Child Restraint System.

Adjust the lap portion of the reference belt to achieve a tension load of  $50 \text{ N} \pm 5 \text{ N}$  at load cell 1. Make a chalk mark on the webbing where it passes through the simulated buckle.

While maintaining the belt at this position, adjust the diagonal to achieve a tension of  $50 \text{ N} \pm 5 \text{ N}$  at load cell 2 by either locking the webbing at the Enhanced Child Restraint System webbing locker or by pulling the belt between the belt clamping mechanism and the standard retractor. If the tension in load cell 2 is achieved by pulling the belt between the clamping mechanism and the retractor, the clamping mechanism shall now be locked.

Extract all webbing from the retractor spool and rewind the excess webbing keeping a tension of  $4 \pm 3 \text{ N}$  in the belt between the retractor and the pillar loop. The spool shall be locked before the dynamic test. Conduct the dynamic crash test.

#### **7.1.3.5.2.3. After installation**

After installation, the dummy position shall be adjusted so that:

The dummy centre line and the Enhanced Child Restraint System centre line shall be aligned exactly with the centre line of the test bench.

The arms of the dummy shall be positioned symmetrically. Elbows shall be positioned in such a way that the upper arms are closely aligned with the sternum.

Hands shall be positioned on the thighs.

Legs shall be positioned parallel to one another or at least symmetrically.

For lateral impact, positive measures shall be taken to ensure the stability of the dummy is maintained until  $t_0$  and this shall be confirmed using video analysis. Any means used to stabilise the dummy before  $t_0$  shall not influence the dummy kinematics after  $t_0$ .

Because the foam of the test bench seat cushion will compress after installation of the Enhanced Child Restraint System, the dynamic test shall be conducted no more than 10 minutes after installation.

To allow the test bench seat cushion to recover, the minimum period between two tests using the same test bench seat cushion shall be 20 minutes.

Example for arm alignment:

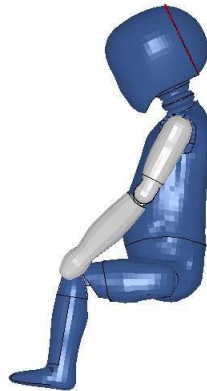

Arms are aligned with sternum

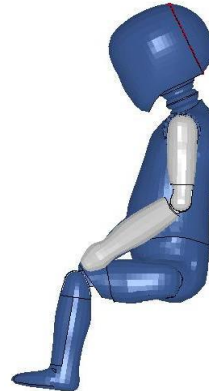

Arms are not aligned with sternum

Paragraph 7.1.3.6., amend to read:

"7.1.3.6. Size indication

The dynamic tests shall be conducted with the largest dummy and the smallest dummy as defined in the following tables according to the size range indicated by the manufacturer for the Enhanced Child Restraint System.

Table 7  
Selection criteria for the dummy according to the range

Size range indication (in cm)	$\leq 60$	$60 < x \leq 75$	$75 < x \leq 87$	$87 < x \leq 105$	$105 < x \leq 125$	$> 125$
Dummy	Q0	Q1	Q1.5	Q3 <sup>2</sup>	Q6	Q10 <sup>1</sup>

<sup>1</sup> No lateral impact test **using the Q10 dummy** is required for i-Size booster seats with a size range upper limit between 125 cm and 135 cm. .

Where the Enhanced Child Restraint System requires ... defined above."

Paragraphs 7.3. to 7.3.3., amend to read:

"7.3. Certification of test bench cushion

7.3.1. The test bench cushion shall be certified when new to establish initial values for **impact peak** deceleration, and then after every 50 dynamic tests or at least every month, whichever is the sooner.

7.3.2. The certification and measuring procedures shall correspond to those specified in the latest version of ISO 6487; the measuring equipment shall correspond to the specification of a data channel with a channel filter class (CFC) 60.

Using the test device defined in Annex 14 to this Regulation, conduct three tests **on the bench base prepared as described in Annex 6, foam covered with textile**,  $150 \pm 5$  mm from the front edge of the cushion on the centre line and at  $150 \pm 5$  mm in each direction from the centre line.

<sup>2</sup> ECRS shall not be approved only on the base of Q3 test results in non-integral configuration

Place the **bench cushion** on a flat rigid **surface**. Place the device vertically above the test point, **at a height of  $500 \pm 5$  mm** and allow it to fall freely to make impact on the seat surface. **Record the** deceleration curve.

- 7.3.3. **The initial peak recorded values for impact deceleration shall be  $24 \pm 4$  g and subsequent peak** values recorded shall not deviate by more than 15 percent from the initial values."

*Paragraph 8.1.*, amend to read:

- "8.1. The test report shall record the results of all tests and measurements including the following test data:
- (a) The type of device used for the test (acceleration or deceleration device),
  - (b) The total velocity change,
  - (c) The trolley speed immediately before impact only for deceleration sleds,
  - (d) The acceleration or deceleration curve during all the velocity change of the trolley and at least 300 ms,
  - (e) The time (in ms) when the head of the manikin reaches its maximum displacement during the performance of the dynamic test,
  - (f) The place occupied by the buckle during the tests, if it can be varied, and
  - (g) **The name and address of the laboratory where tests have been performed,**
  - (h) And any failure or breakage,
  - (i) The following dummy criteria: HPC, Head acceleration **Cum3ms**, Upper neck tension force, Upper neck moment, Chest acceleration **Cum3ms, Chest deflection**; Abdominal Pressure (in frontal impact); and
  - (j) **Adult Seat belt bench installation forces."**

*Insert new paragraph 14.2.2.*, to read:

- "14.2.2. **For i-Size booster seat category Enhanced Child Restraint Systems the following label shall be clearly visible on the exterior of the packing:**

*Notice*

**This is a i-Size booster seat Enhanced Child Restraint System. It is approved according to Regulation No. 129, for use primarily in " i-Size seating positions" as indicated by vehicle manufacturers in the vehicle user's manual.**

**If in doubt, consult either the Enhanced Child Restraint System manufacturer or the retailer.**

*Paragraphs 14.2.2. to 14.2.8.(former)*, renumber as 14.2.3. to 14.2.9.

Insert new paragraphs 16.5. and 16.6., to read:

- "16.5. As from the official date of entry into force of the 02 series of amendments to this Regulation, no Contracting Party applying this Regulation shall refuse to grant or refuse to accept type approvals to this Regulation as amended by the 02 series of amendments.
- 16.6. Until 1 September 2020, type approvals to the preceding series of amendments to the Regulation which are not affected by the 02 series of amendments to the Regulation shall remain valid and Contracting Parties applying this Regulation shall continue to accept them.
- 16.7. Until 1 September 2022, Contracting Parties applying this Regulation shall not refuse to grant extensions of approval to the 01 series of amendments to this Regulation."

Paragraphs 14.2.2. to 14.2.8.(former), renumber as paragraphs 14.2.3. to 14.2.9.

Annex 2, amend to read:

## "Annex 2

### Arrangements of the approval mark

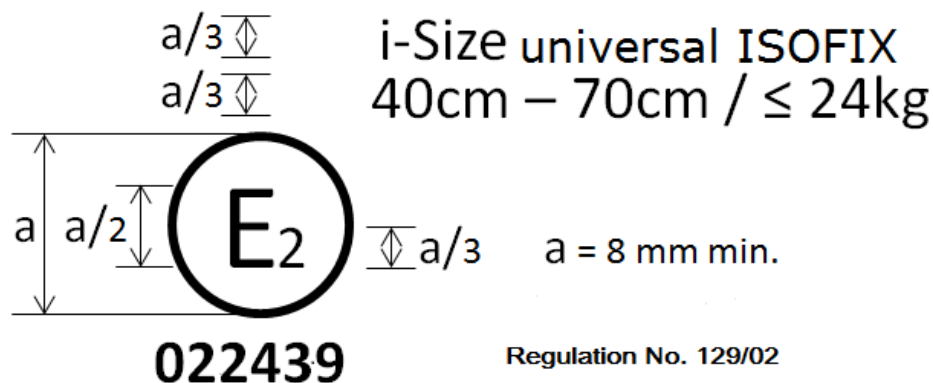

The Enhanced Child Restraint System bearing the above approval mark is a device capable of being fitted in any i-size seating position of the vehicle and of being used for the 40 cm - 70 cm size range and mass limit of 24 kg; it is approved in France (E 2) under the number 022439. The approval number indicates that the approval was granted in accordance with the requirements of the Regulation concerning the approval of Enhanced Child Restraint Systems used onboard of motor vehicles as amended by the 02 series of amendments. In addition the name of the regulation has to be identified on the approval mark followed by the series of amendment according to which the approval has been granted.



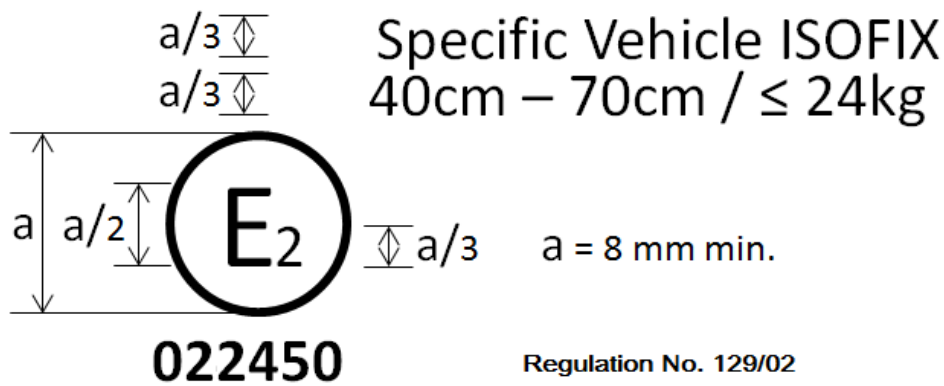

The Enhanced Child Restraint System bearing the above approval mark is a device not capable of being fitted in every vehicle and capable of being used for the 40 cm - 70 cm size range and mass limit of 24 kg; it is approved in France (E 2) under the number 022450. The approval number indicates that the approval was granted in accordance with the requirements of the Regulation concerning the approval of Specific vehicle ISOFIX Enhanced Child Restraint Systems used onboard of motor vehicles as amended by the 02 series of amendments. In addition the name of the regulation has to be identified on the approval mark followed by the series of amendment according to which the approval has been granted.

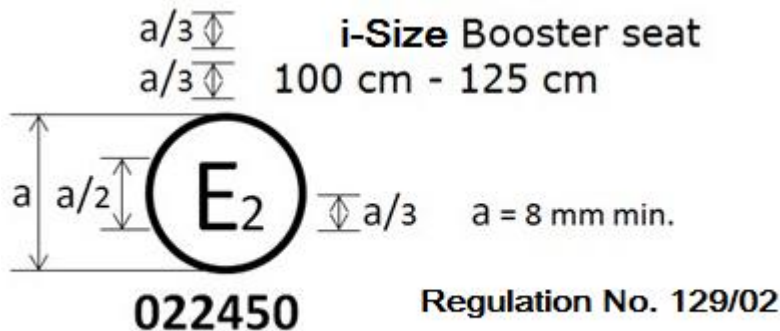

The Enhanced Child Restraint System bearing the above approval mark can be fitted in any i-Size booster seating position and used for the 100 cm - 125 cm size range; it is approved in France (E 2) under the number 022450. The approval number indicates that the approval was granted in accordance with the requirements of the Regulation concerning the approval of Enhanced Child Restraint Systems used on-board of motor vehicles as amended by the 02 series of amendments. In addition, the name of the regulation is to be identified on the approval mark followed by the series of amendment according to which the approval has been granted.

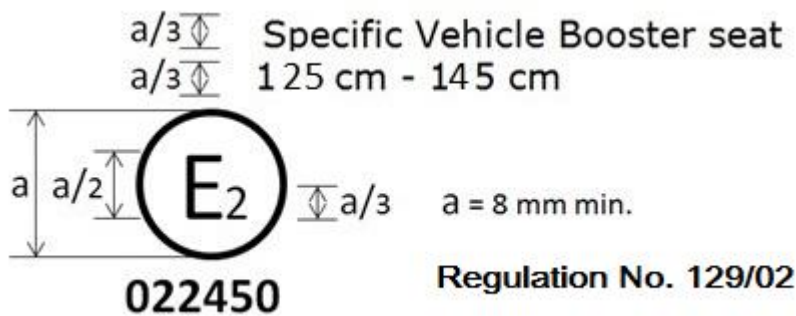

The Enhanced Child Restraint System bearing the above approval mark is a device not capable of being fitted in every vehicle but capable of except being used for the 125 cm - 145 cm size range; it is approved in France (E 2) under the number 022450. The approval number indicates that the approval was granted in accordance with the requirements of the Regulation concerning the approval of specific vehicle booster seat Enhanced Child Restraint Systems used on-board of motor vehicles as amended by the 02 series of amendments. In addition the name of the Regulation needs to be identified on the approval mark followed by the series of amendment according to which the approval has been granted.

In case the ECRS is equipped with a module, the size range is not on the approval mark but on the module mark.

### Arrangements of the approval mark in combination with a module mark

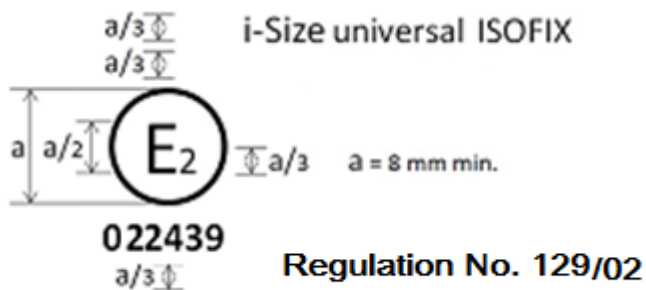

The Enhanced Child Restraint System bearing the above approval mark is a device, including module(s), capable of being fitted in any i-size compatible vehicle seating position. It is approved in France (E 2) under the number 022439. The approval number indicates that the approval was granted in accordance with the requirements of the Regulation concerning the approval of Enhanced Child Restraint Systems used onboard of motor vehicles as amended by the 02 series of amendments. In addition the name of the regulation has to be identified on the approval mark followed by the series of amendment according to which the approval has been granted.



indicates that the approval was granted in accordance with the requirements of the Regulation concerning the approval of Enhanced Child Restraint Systems used onboard of motor vehicles as amended by the **02** series of amendments."

*Annex 6, Appendix 2, amend to read:*

## "Annex 6 - Appendix 2

### Arrangement and use of anchorages on the test trolley

1. The anchorages shall be positioned as shown in the figure below.
2. Enhanced Child Restraint Systems in the i-Size universal, specific and restricted categories shall use the following anchorage points: H<sub>1</sub> and H<sub>2</sub>.
3. For testing of Enhanced Child Restraint Systems with top tether, the anchorage G<sub>1</sub> or G<sub>2</sub> shall be used.
4. In the case of Enhanced Child Restraint Systems utilising a support-leg, the Technical Service shall select the anchorages to be used according to paragraph 3. above and with the support-leg adjusted as specified in paragraph 7.1.3.6.3. of this Regulation.
5. The structure carrying the anchorages shall be rigid. The upper anchorages shall not be displaced by more than 0.2 mm in the longitudinal direction when a load of 980 N is applied to them in that direction. The trolley shall be so constructed that no permanent deformation shall occur in the parts bearing the anchorages during the test.

Figure 1

**Top View – Bench with ISOFIX anchorages (Tolerance general: ±2 mm)**

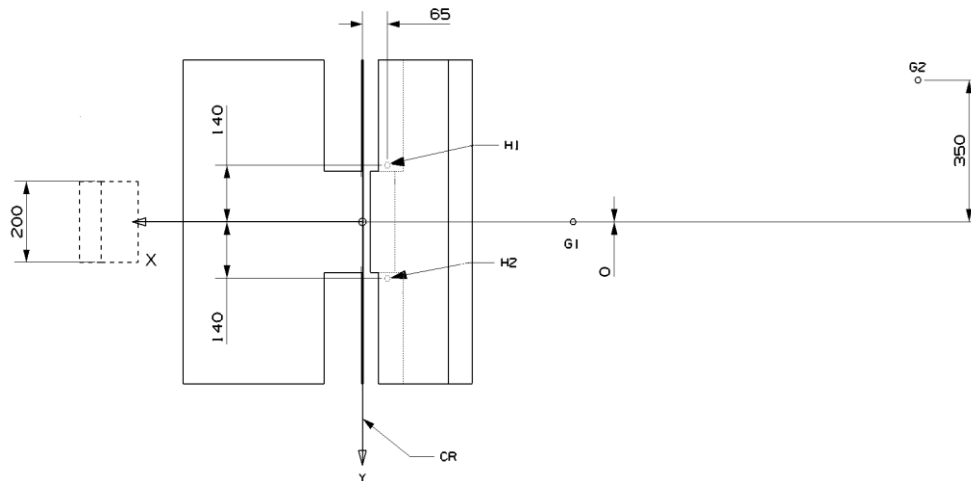
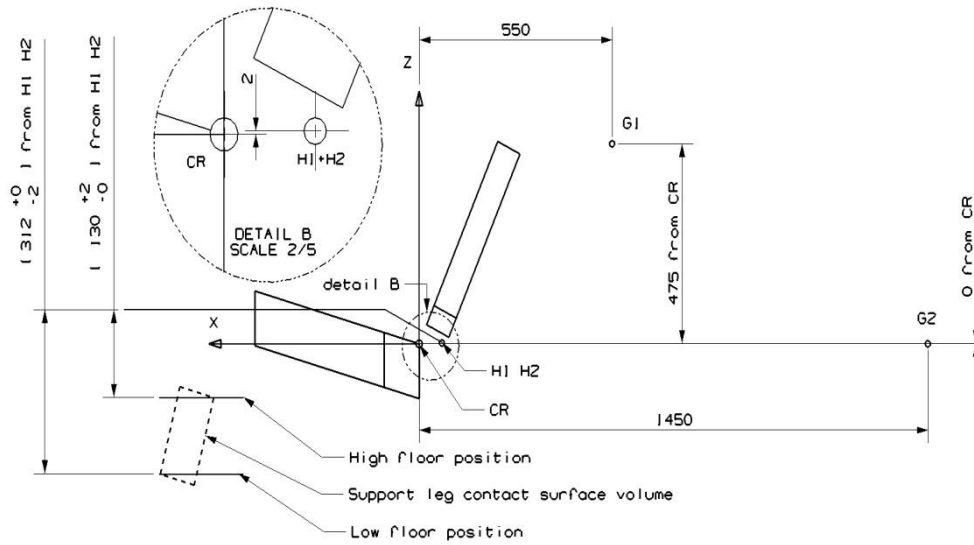

Figure 2  
Side View – Bench with anchorages (Tolerance general:  $\pm 2$  mm)



## Definition of belt anchorages

Table 1  
Belt anchorages points

Direction	Upper Anchorage (P)			Buckle (A2)			Lower outer (A1)		
	X	Y	Z	X	Y	Z	X	Y	Z
Distance (mm)	-240	-220	-630	-29	200	59	10	-200	14.5

Figure 3  
Top View – Bench with belt anchorages (Tolerance general:  $\pm 2$  mm)

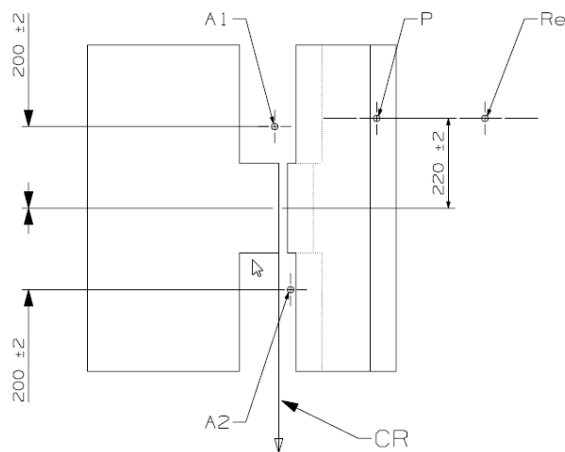

"Re" is located on the centre line of the retractor spool

**Figure 4**  
**Side View – Bench with belt anchorages (Tolerance general:  $\pm 2$  mm)**

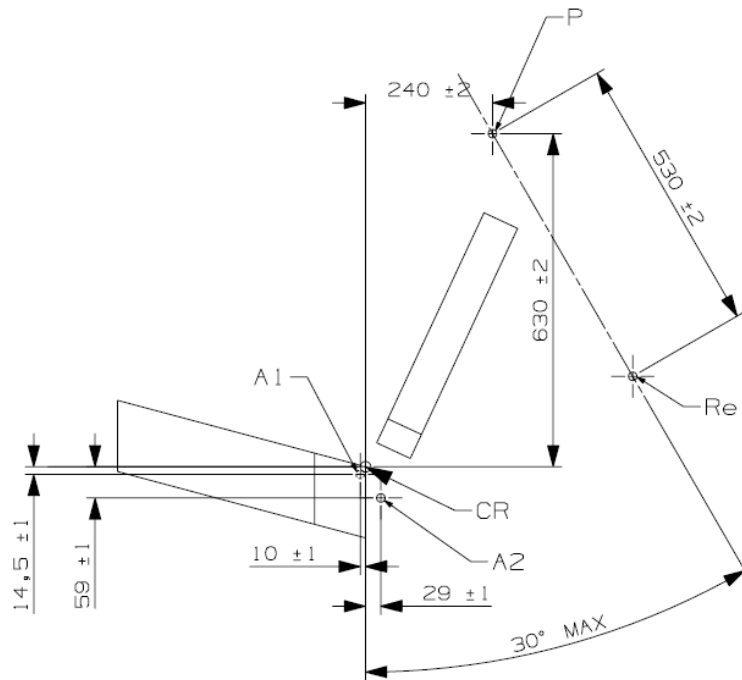

**"Re" is located on the centre line of the retractor spool"**

*Annex 17, paragraph 1.2.4., amend to read:*

"1.2.4. Values of HPC for which the time interval ( $t_1 - t_2$ ) is greater than 15 ms are ignored for the purposes of calculating the maximum value."

Annex 18, amend to read:

## "Annex 18

### Geometrical dimensions of Enhanced Child Restraint Systems

Figure 1

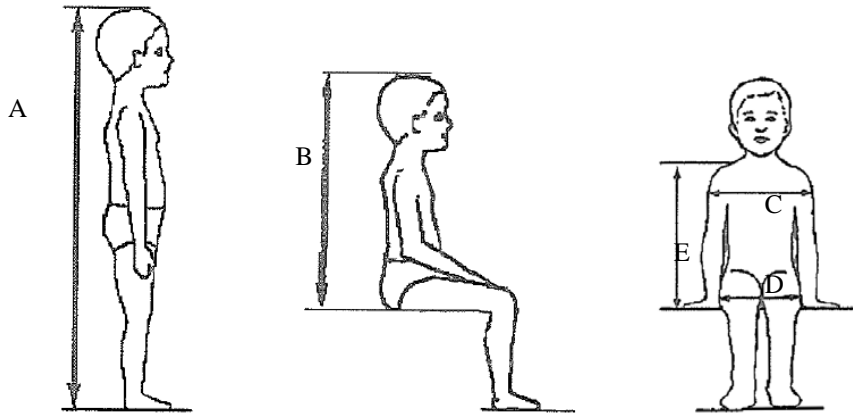

<i>Stature cm</i>	<i>Minimum Sitting height cm</i>	<i>Minimum Shoulder breadth cm</i>	<i>Minimum Hip breadth cm</i>	<i>Minimum Shoulder height cm</i>	<i>Maximum Shoulder height cm</i>
<i>A</i>	<i>B</i>	<i>C</i>	<i>D</i>	<i>E1</i>	<i>E2</i>
	<i>95%ile</i>	<i>95%ile</i>	<i>95%ile</i>	<i>5%ile</i>	<i>95%ile</i>
≤40				≤27.4	
45	39.0	12.1	14.2	27.4	29.0
50	40.5	14.1	14.8	27.6	29.2
55	42.0	16.1	15.4	27.8	29.4
60	43.5	18.1	16.0	28.0	29.6
65	45.0	20.1	17.2	28.2	29.8
70	47.1	22.1	18.4	28.3	30.0
75	49.2	24.1	19.6	28.4	31.3
80	51.3	26.1	20.8	29.2	32.6
85	53.4	26.9	22.0	30.0	33.9
90	55.5	27.7	22.5	30.8	35.2
95	57.6	28.5	23.0	31.6	36.5
100	59.7	29.3	23.5	32.4	37.8
105	61.8	30.1	24.9	33.2	39.1
110	63.9	30.9	26.3	34.0	40.4
115	66.0	32.1	27.7	35.5	41.7
120	68.1	33.3	29.1	37.0	43.0
125	70.2	<b>33.3</b>	<b>29.1</b>	38.5	44.3

<i>Stature cm</i>	<i>Minimum Sitting height cm</i>	<i>Minimum Shoulder breadth cm</i>	<i>Minimum Hip breadth cm</i>	<i>Minimum Shoulder height cm</i>	<i>Maximum Shoulder height cm</i>
<i>A</i>	<i>B</i>	<i>C</i>	<i>D</i>	<i>E1</i>	<i>E2</i>
	<i>95%ile</i>	<i>95%ile</i>	<i>95%ile</i>	<i>5%ile</i>	<i>95%ile</i>
130	72.3	<b>33.3</b>	<b>29.1</b>	40.0	46.1
135	74.4	<b>33.3</b>	<b>29.1</b>	41.5	47.9
140	76.5	<b>34.2</b>	<b>29.6</b>	43.0	49.7
145	78.6	<b>35.3</b>	<b>30.8</b>	44.5	51.5
150	81.1	<b>36.4</b>	<b>32.0</b>	46.3	53.3

..."

Annex 20, amend to read:

**"Minimum list of documents required for approval**

	i-Size or <b>i-Size booster seat</b> ECRS	Specific vehicle, ISOFIX or booster <b>seat</b> ECRS	paragraph:
General documents	Application letter/request	Application letter/request	3.1.

..."



Annex 21, amend to read:

## "Annex 21

...

### Load application device II

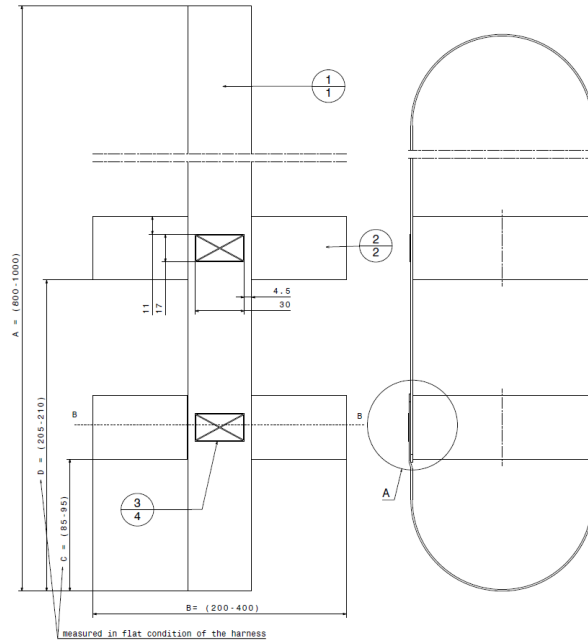

...

Insert new Annex 23, to read:

## "Annex 23

### Standard safety-belt

1. The safety-belt for the dynamic test and for the maximum length requirements shall be made according to the configuration shown in Figure 1. These are a three-point retracting belt system.
2. The three-point retracting belt has the following rigid parts: a retractor (R), a pillar loop (P), two anchorage points (A1 and A2) (see Figure 1), and a central part (N, in detail in Figure 3). The retractor shall comply with the requirements of Regulation No. 16 (paragraph 6.2.5.2.2.) for retraction force. The retractor spool diameter is  $33 \pm 0.5$  mm [(example is given in Mutual Resolution No. 1 (M.R.1))].
3. The retracting belt shall be fitted to the anchorages on the test bench, described in Annex 6, Appendix 2 as follows:
  - (a) Belt anchorage A1 shall be fitted to trolley anchorages B0 (outboard);
  - (b) Belt anchorage A2 shall be fitted to trolley anchorage A (inboard);
  - (c) Belt pillar loop P shall be fitted to trolley anchorage C;

- (d) Belt retractor R shall be fitted to trolley anchorage such that the spool centre line is positioned on Re.

The value of X in Figure 1 below is  $200 \pm 5$  mm. The effective strap length between A1 and the centre line of the retractor spool Re (when the webbing is fully extracted including the minimum length of 150 mm for testing of Enhanced Child Restraint System shall be  $[2,820] \pm 5$  mm when measured in a straight line without load and on a horizontal surface. This length may be increased for the testing of restricted categories; for all categories with the Enhanced Child Restraint System installed, there shall be a minimum of 150 mm of strap length on the retractor spool.

4. The strap requirements for the belt as follows:
- (a) Material: polyester spinnblack;
  - (b) Width:  $48 \pm 2$  mm at 10,000 N;
  - (c) Thickness:  $1.0 \pm 0.2$  mm;
  - (d) Elongation:  $8 \pm 2$  per cent at 10,000 N.

Figure 1  
Standard seat belt configurations

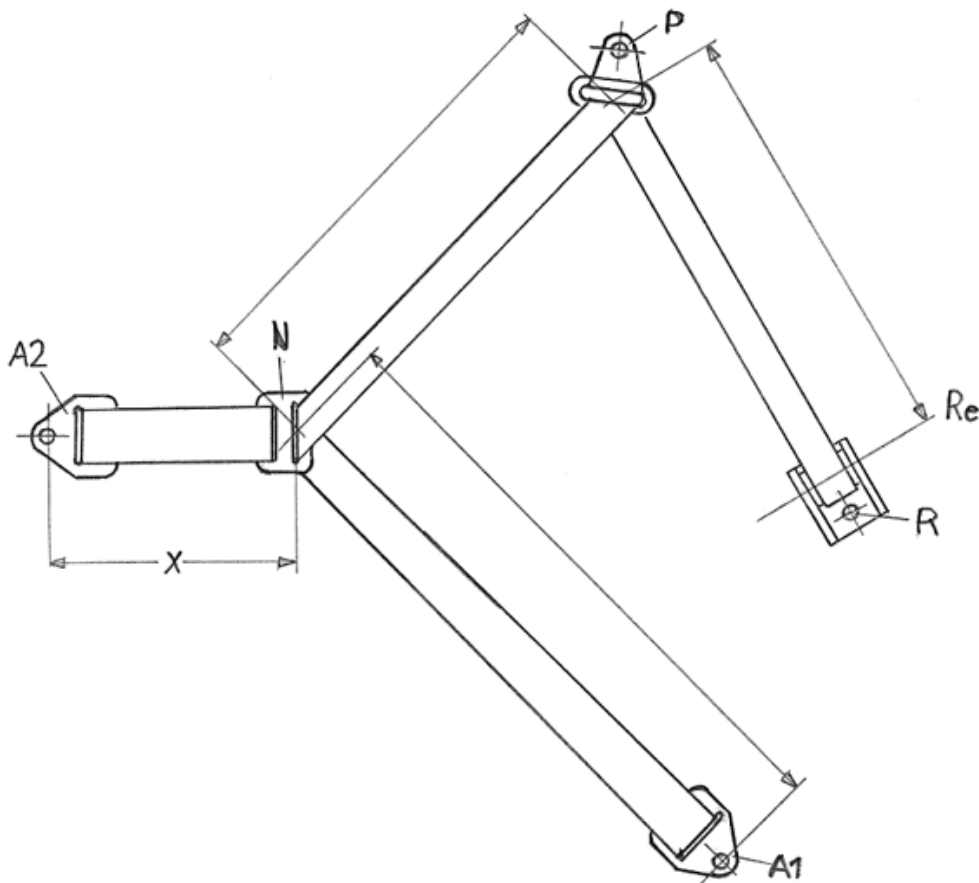

Figure 2  
Typical standard anchorage plate

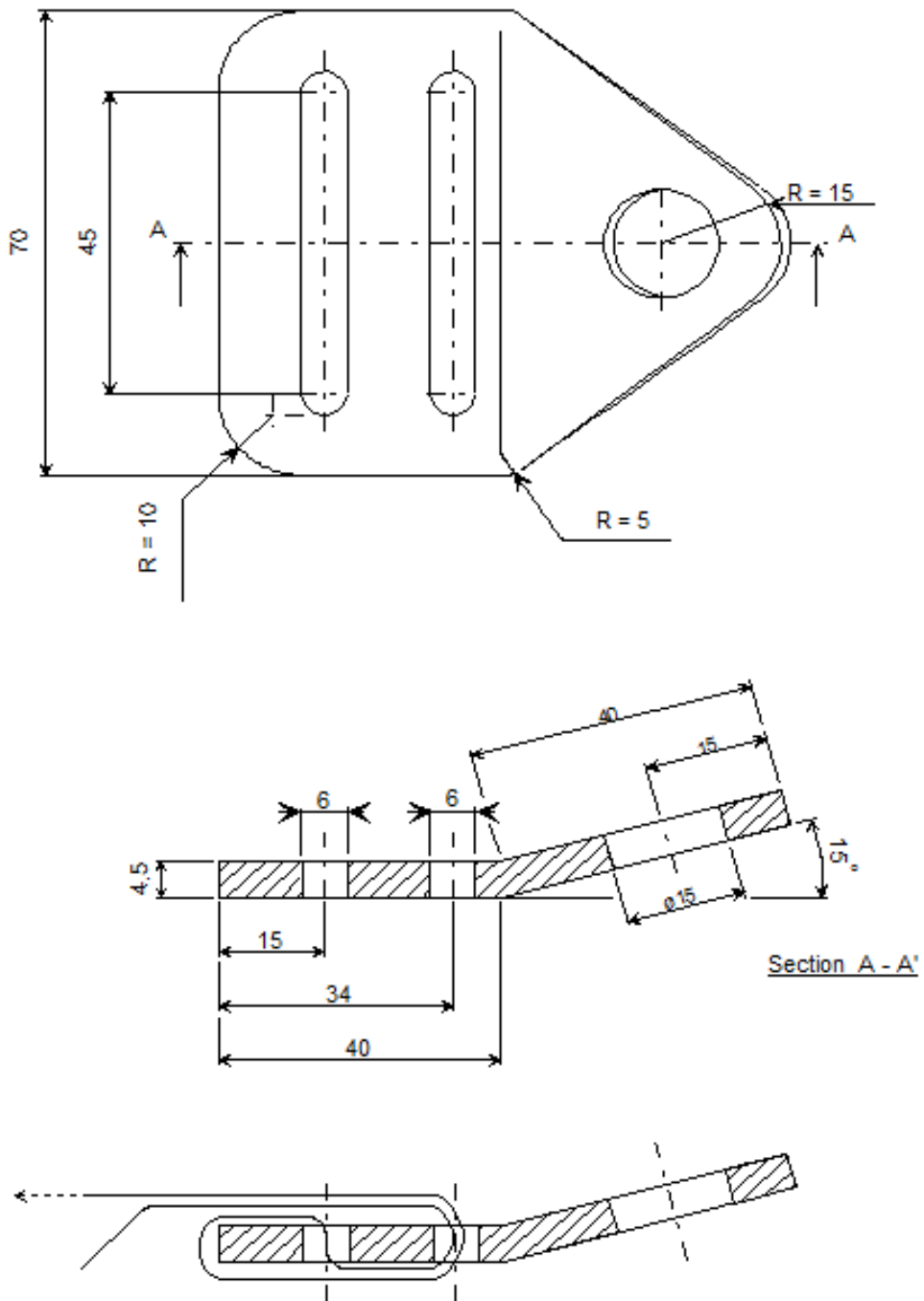
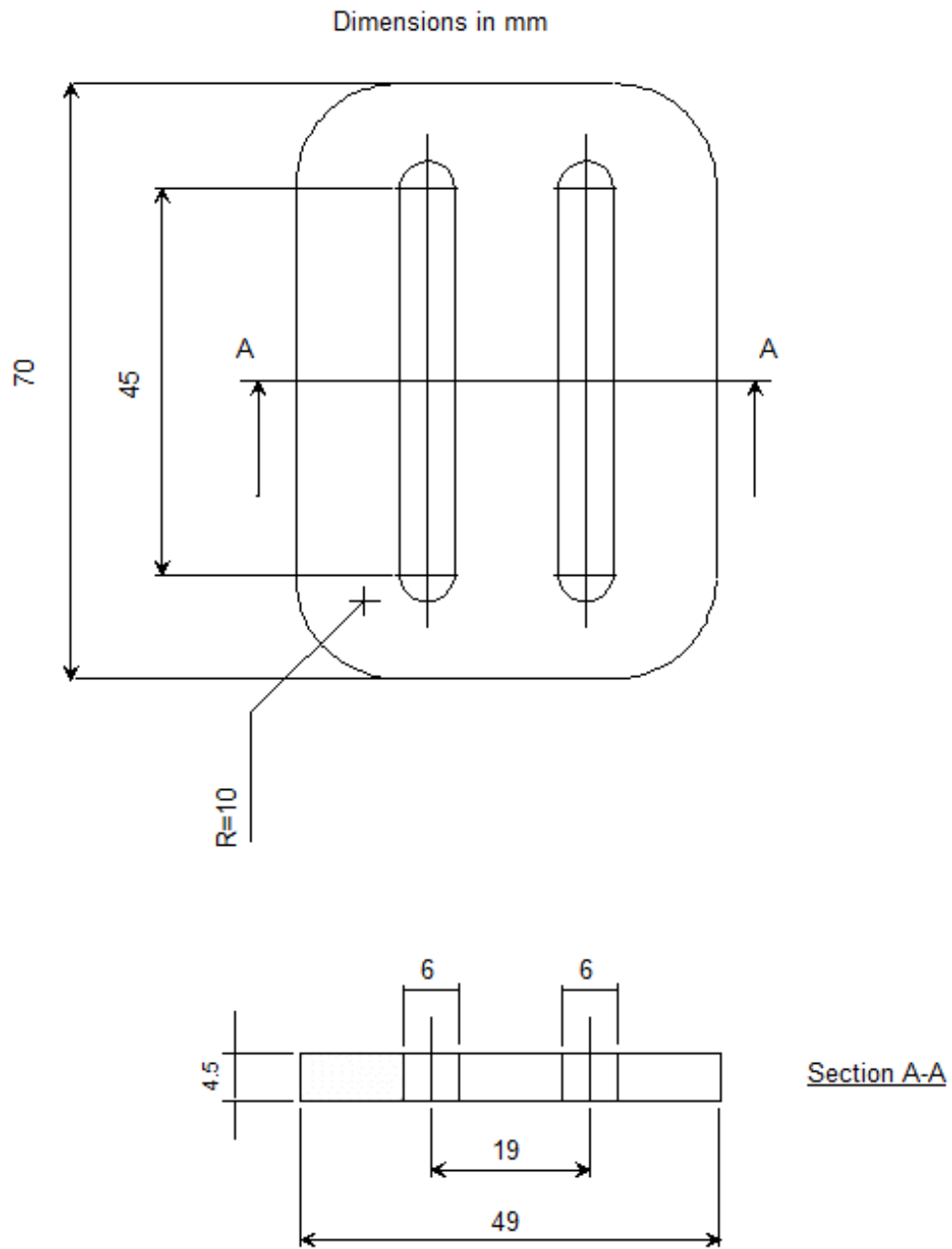

Figure 3  
Central part of the standard belt configuration



**Figure 4**  
**Pillar loop**

**Finish: Chromium plated**

