

Proposal for collective amendments to Regulation Nos. 44 and 129

I. Proposal for Supplement 10 to the 04 series of amendments to Regulation No. 44 (Child restraint systems)

Paragraph 6.1.6., amend to read:

~~The child restraint manufacturer has to declare in written form that the flammability of materials used to manufacture the restraint system is in conformity with the parts of EN 71:2009 part 2. Tests confirming the validity of the declaration may be carried out at the discretion of the test authority.~~

The applicant shall declare in writing that when testing materials in accordance with Annex 24 of this regulation, the materials used shall not burn, nor transmit a flame front across its surface, at a rate of more than [250] mm per minute. Each material used in a child restraint system shall conform to these requirements. However, the requirement concerning transmission of a flame front shall not apply to a surface created by cutting a test specimen for purposes of testing pursuant to Annex 24.

In the case of a built-in child restraint system, the requirements shall be met in both the "in-use" and in the "stowed" positions.

If a material stops burning before it has burned for 60 seconds from the start of timing, and has not burned more than 51 mm from the point where the timing was started, it shall be considered to meet the burn-rate requirement specified above.

Add a new annex 24 to read:

ANNEX 24

Flammability of materials intended to be used in child restraint systems

1. Definitions
"Occupant compartment air space" means the space within the occupant compartment that normally contains refreshable air.
2. Material selection (see Figure 1 below)
 - 2.1. Any portion of a single or composite material which is within 13 mm of the occupant compartment air space shall meet the requirements in Paragraph 6.1.6.
 - 2.1.1 Any material that does not adhere to other material(s) at every point of contact shall meet the requirements of Paragraph 6.1.6. when tested separately
 - 2.1.2 Any material that adheres to other materials at every point of contact shall meet the requirements of Paragraph 6.1.6. when tested as a composite with the other material(s).

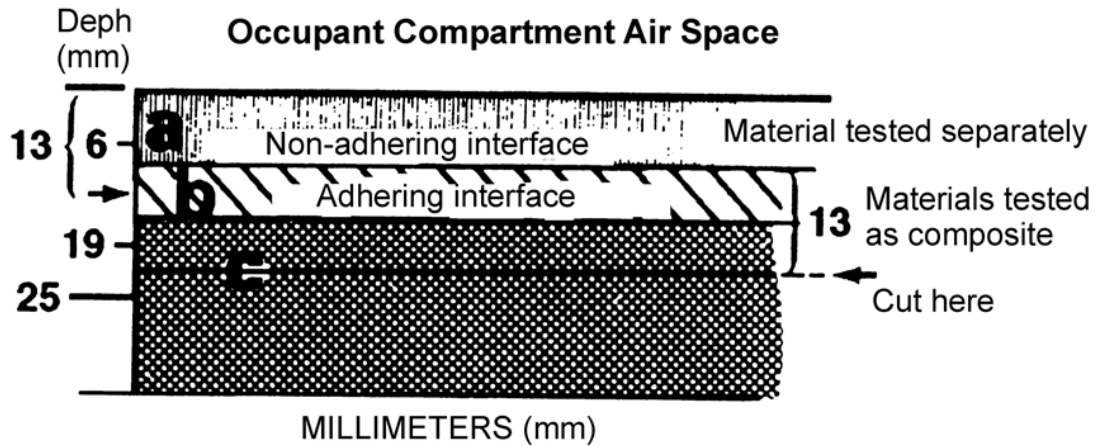

Figure 1

Material A has a non-adhering interface with material B and is tested separately. Part of material B is within 13 mm of the occupant compartment air space, and materials B and C adhere at every point of contact; therefore, B and C are tested as a composite. The cut is in material C as shown, to make a specimen 13 mm thick.

3. Test procedure

- 3.1 The test is conducted in a metal cabinet for protecting the test specimens from drafts. The interior of the cabinet is 381 mm long, 203 mm deep, and 356 mm high. It has a glass observation window in the front, a closable opening to permit insertion of the specimen holder, and a hole to accommodate tubing for a gas burner. For ventilation, it has a 13 mm clearance space around the top of the cabinet, ten holes in the base of the cabinet, each hole 19 mm in diameter and legs to elevate the bottom of the cabinet by 10 mm, all located as shown in Figure 2.
- 3.2 Prior to testing, each specimen is conditioned for 24 hours at a temperature of 21 deg.C, and a relative humidity of 50 percent, and the test is conducted under those ambient conditions.
- 3.3 The test specimen is inserted between two matching U-shaped frames of metal stock 25 mm wide and 10 mm high. The interior dimensions of the U-shaped frames are 51 mm wide by 330 mm long. A specimen that softens and bends at the flaming end so as to cause erratic burning is kept horizontal by supports consisting of thin, heat-resistant wires, spanning the width of the U-shaped frame under the specimen at 25 mm intervals. A device that may be used for supporting this type of material is an additional U-shaped frame, wider than the U-shaped frame containing the specimen, spanned by 10-mil wires of heat-resistant composition at 25 mm intervals, inserted over the bottom U-shaped frame.
- 3.4 A bunsen burner with a tube of 10 mm inside diameter is used. The gas adjusting valve is set to provide a flame, with the tube vertical, of 38 mm in height. The air inlet to the burner is closed.
- 3.5 The gas supplied to the burner has a flame temperature equivalent to that of natural gas.

4. Preparation of specimens

- 4.1. Each specimen of material to be tested shall be a rectangle 102 mm wide by 356 mm long, wherever possible.
The thickness of the specimen is that of the single or composite material used in the vehicle, except that if the material's thickness exceeds 13 mm, the specimen is cut down to that thickness measured from the surface of the specimen closest to the occupant compartment air space.
Where it is not possible to obtain a flat specimen because of surface curvature, the specimen is cut to not more than 13 mm in thickness at any point.
The maximum available length or width of a specimen is used where either dimension is less than 356 mm or 102 mm.
- 4.2. The specimen is produced by cutting the material in longitudinal as well as transvers direction.

The specimen is oriented so that the surface closest to the occupant compartment air space faces downward on the test frame.
- 4.3. Material with a napped or tufted surface is placed on a flat surface and combed twice against the nap with a comb having seven to eight smooth, rounded teeth per 25 mm.

5. Test

- 5.1. Mount the specimen so that both sides and one end are held by the U-shaped frame, and specimen is not more than 51 mm, so that the sides of the specimen cannot be held in the U-shaped frame, place the specimen in position on wire supports as described in 2.3, with one end held by the closed end of the U-shaped frame.
- 5.2. Place the mounted specimen in a horizontal position, in the center of the cabinet.
- 5.3. With the flame adjusted according to 2.4, position the bunsen burner and specimen so that the center of the burner tip is 19 mm below the center of the bottom edge of the open end of the specimen.
- 5.4. Expose the specimen to the flame for 15 seconds.
- 5.5. Begin timing (without reference to the period of application of the burner flame) when the flame from the burning specimen reaches a point 38 mm from the open end of the specimen.
- 5.6. Measure the time that it takes the flame to progress to a point 38 mm from the clamped end of the specimen. If the flame does not reach the specified end point, time its progress to the point where flaming stops.
- 5.7. Calculate the burn rate from the formula:

$$B = 60 \times (D/T)$$

Where:

B = Burn rate in millimeters per minute

D = Length the flame travels in millimeters, and

T = Time in seconds for the flame to travel D millimeters.

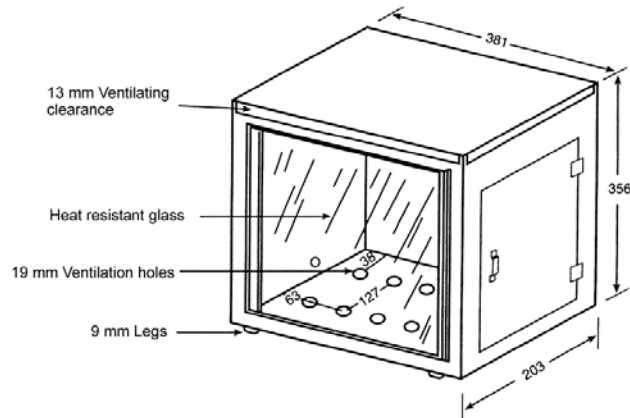

Figure 2
All dimensions in millimeters (mm)

II. Proposal for Supplement 05 to the 00 series of amendments to Regulation No. 129 (Enhanced Child restraint systems)

Paragraph 6.3.1.2., amend to read:

~~The Child Restraint System manufacturer shall declare in writing that the flammability of materials used to manufacture the restraint system is in conformity with the relevant paragraphs of EN 71-2:2011. Tests confirming the validity of the declaration may be carried out at the discretion of the Technical Service.~~

The applicant shall declare in writing that when testing materials in accordance with Annex 24 of this regulation, the materials used shall not burn, nor transmit a flame front across its surface, at a rate of more than [250] mm per minute. Each material used in a child restraint system shall conform to these requirements. However, the requirement concerning transmission of a flame front shall not apply to a surface created by cutting a test specimen for purposes of testing pursuant to Annex 24.

In the case of a built-in child restraint system, the requirements shall be met in both the "in-use" and in the "stowed" positions.

If a material stops burning before it has burned for 60 seconds from the start of timing, and has not burned more than 51 mm from the point where the timing was started, it shall be considered to meet the burn-rate requirement specified above.

Add a new annex 23 to read:

ANNEX 23

Flammability of materials intended to be used in child restraint systems

1. Definitions
"Occupant compartment air space" means the space within the occupant compartment that normally contains refreshable air.
2. Material selection (see Figure 1 below)
 - 2.1. Any portion of a single or composite material which is within 13 mm of the occupant compartment air space shall meet the requirements in Paragraph 6.3.1.2.

2.1.1 Any material that does not adhere to other material(s) at every point of contact shall meet the requirements of Paragraph 6.3.1.2. when tested separately

2.1.2 Any material that adheres to other materials at every point of contact shall meet the requirements of Paragraph 6.3.1.2. when tested as a composite with the other material(s).

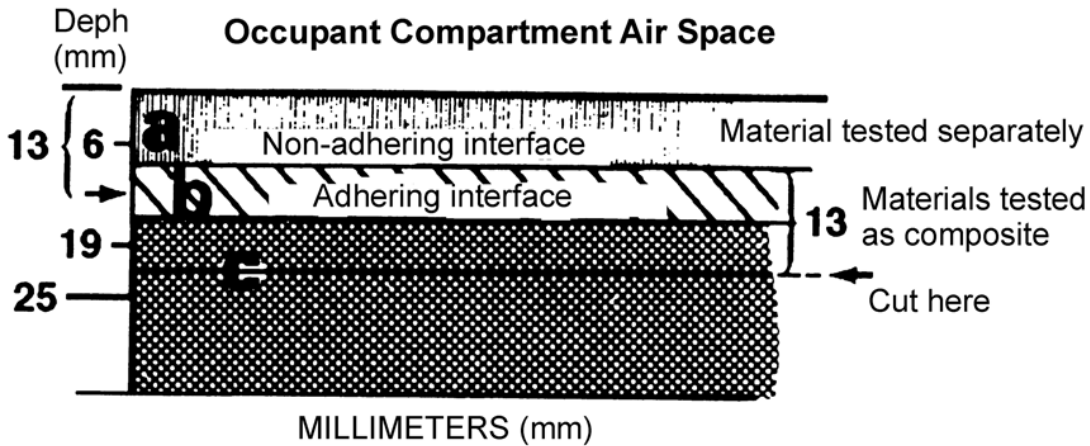

Figure 1

Material A has a non-adhering interface with material B and is tested separately. Part of material B is within 13 mm of the occupant compartment air space, and materials B and C adhere at every point of contact; therefore, B and C are tested as a composite. The cut is in material C as shown, to make a specimen 13 mm thick.

3. Test procedure

- 3.1 The test is conducted in a metal cabinet for protecting the test specimens from drafts. The interior of the cabinet is 381 mm long, 203 mm deep, and 356 mm high. It has a glass observation window in the front, a closable opening to permit insertion of the specimen holder, and a hole to accommodate tubing for a gas burner. For ventilation, it has a 13 mm clearance space around the top of the cabinet, ten holes in the base of the cabinet, each hole 19 mm in diameter and legs to elevate the bottom of the cabinet by 10 mm, all located as shown in Figure 2.
- 3.2. Prior to testing, each specimen is conditioned for 24 hours at a temperature of 21 deg.C, and a relative humidity of 50 percent, and the test is conducted under those ambient conditions.
- 3.3. The test specimen is inserted between two matching U-shaped frames of metal stock 25 mm wide and 10 mm high.
The interior dimensions of the U-shaped frames are 51 mm wide by 330 mm long.
A specimen that softens and bends at the flaming end so as to cause erratic burning is kept horizontal by supports consisting of thin, heat-resistant wires, spanning the width of the U-shaped frame under the specimen at 25 mm intervals.
A device that may be used for supporting this type of material is an additional U-shaped frame, wider than the U-shaped frame containing the specimen, spanned by 10-mil wires of heat-resistant composition at 25 mm intervals, inserted over the bottom U-shaped frame.
- 3.4. A bunsen burner with a tube of 10 mm inside diameter is used.
The gas adjusting valve is set to provide a flame, with the tube vertical, of 38 mm in height. The air inlet to the burner is closed.
- 3.5. The gas supplied to the burner has a flame temperature equivalent to that of natural gas.

4. Preparation of specimens

- 4.1. Each specimen of material to be tested shall be a rectangle 102 mm wide by 356 mm long, wherever possible.
The thickness of the specimen is that of the single or composite material used in the vehicle, except that if the material's thickness exceeds 13 mm, the specimen is cut down to that thickness measured from the surface of the specimen closest to the occupant compartment air space.
Where it is not possible to obtain a flat specimen because of surface curvature, the specimen is cut to not more than 13 mm in thickness at any point.
The maximum available length or width of a specimen is used where either dimension is less than 356 mm or 102 mm.
- 4.2. The specimen is produced by cutting the material in the longitudinal as well as transvers direction. The specimen is oriented so that the surface closest to the occupant compartment air space faces downward on the test frame.
- 4.3. Material with a napped or tufted surface is placed on a flat surface and combed twice against the nap with a comb having seven to eight smooth, rounded teeth per 25 mm.

5. Test

- 5.1. Mount the specimen so that both sides and one end are held by the U-shaped frame, and specimen is not more than 51 mm, so that the sides of the specimen cannot be held in the U-shaped frame, place the specimen in position on wire supports as described in 2.3, with one end held by the closed end of the U-shaped frame.
- 5.2. Place the mounted specimen in a horizontal position, in the center of the cabinet.
- 5.3. With the flame adjusted according to 2.4, position the bunsen burner and specimen so that the center of the burner tip is 19 mm below the center of the bottom edge of the open end of the specimen.
- 5.4. Expose the specimen to the flame for 15 seconds.
- 5.5. Begin timing (without reference to the period of application of the burner flame) when the flame from the burning specimen reaches a point 38 mm from the open end of the specimen.
- 5.6. Measure the time that it takes the flame to progress to a point 38 mm from the clamped end of the specimen. If the flame does not reach the specified end point, time its progress to the point where flaming stops.
- 5.7. Calculate the burn rate from the formula:

$$B = 60 \times (D/T)$$

Where:

B = Burn rate in millimeters per minute

D = Length the flame travels in millimeters, and

T = Time in seconds for the flame to travel D millimeters.

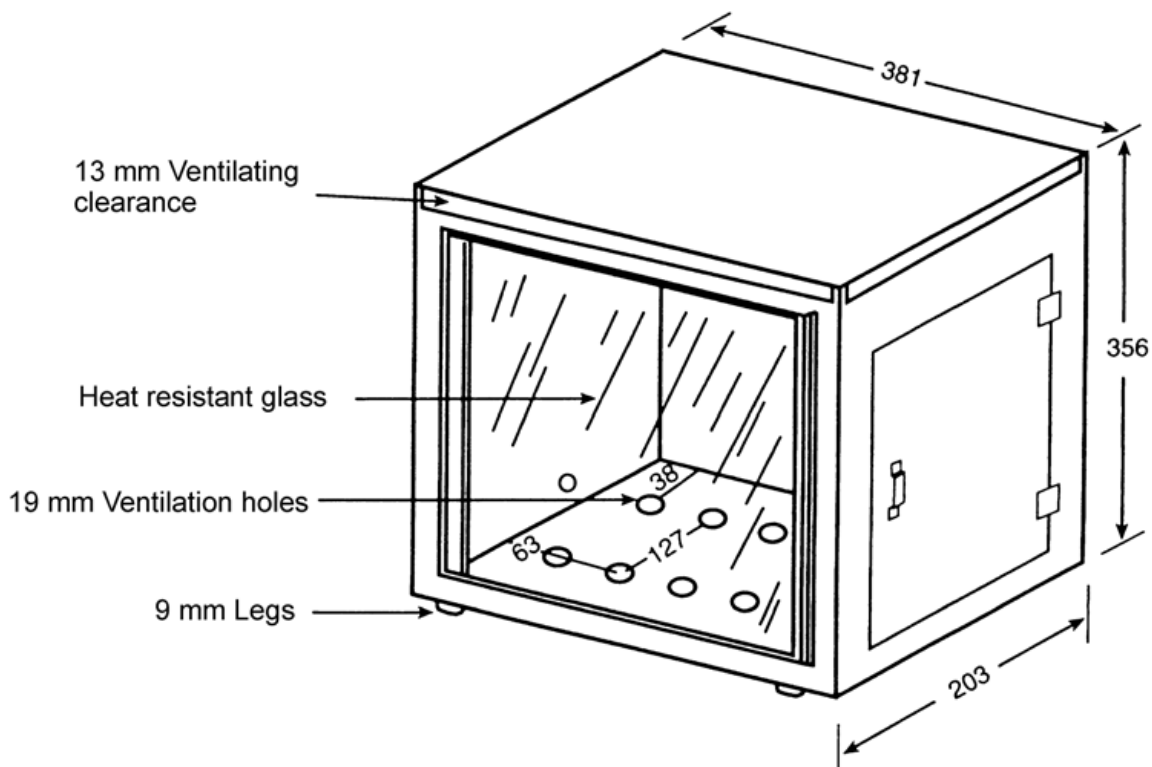

Figure 2
All dimensions in millimeters (mm)

2 Justification

Further to the discussions at the May 2015 GRSP session on the issue of flammability requirements of the materials used in CRS construction, Sweden and Denmark suggest copying the test procedure applied in FMVSS 302, which is commonly and widely used throughout the industry.

This ensures safe materials used in child restraints and the proposed method would also harmonise with international common practice.

As to the required maximum burn rate, GRSP is requested to reach a decision.
