

Proposal for the 02 series of amendments to Regulation No. 127 (Pedestrian safety) – Proposal of amendments to ECE/TRANS/WP.29/GRSP/2015/8 submitted by the expert from the European Commission as Chair of the Task Force on Bumper Test Area within the Informal Working Group on global technical regulation No. 9 Phase 2*

The text reproduced below was prepared by the experts in the Task Force on Bumper Test Area (TF-BTA) which is a subgroup of the Informal Working Group on global technical regulation No. 9, Phase 2. TF-BTA proposes an amendment to the provisions of the bumper test. This text is based on informal document GRSP-56-41 distributed and endorsed, in principle, during the fifty-sixth session of the Working Party on Passive Safety (GRSP)(ECE/TRANS/WP.29/GRSP/56, para. 32). The modifications to the current text of the UN Regulation are marked in bold for new or strikethrough for deleted characters. **Further amendments requested by OICA are highlighted in red.**

I. Proposal

Insert new paragraph 2.12., to read:

"2.12. "Bumper beam" means the structural cross member under the bumper fascia protecting the front of the vehicle. The beam does not include foam, cover support or any pedestrian protection devices."

Former paragraph 2.12., renumber as paragraph 2.13.

Former paragraph 2.13., renumber as paragraph 2.14. and amend to read:

"2.14. "Bumper test area" means ~~the frontal surface of the bumper limited by two longitudinal vertical planes intersecting points 66 mm inside the defined corners of the bumpers.~~ either the front vehicle fascia between the left and right corner of bumper as defined in paragraph 2.17., ~~minus the areas covered by the distance of 42 mm inboard of each corner of bumper, with this distance to be set from the most outboard point with a flexible tape held tautly along the outer surface of the vehicle,~~ or the outermost ends of the bumper beam as defined in paragraph 2.12. (see Figure 5D), whichever area is wider, **minus the areas inboards covered by a distance of 42 mm in transversal direction. ~~This distance is to be set with a flexible tape held tautly along the outer surface of the vehicle."~~**

Former paragraphs 2.14. and 2.15., renumber as paragraphs 2.15. and 2.16.

Former paragraph 2.16., renumber as paragraph 2.17. and amend to read:

"2.17. "Corner of bumper" means ~~the transversal position of the vehicle's point of contact with a vertical plane which makes an angle of 60° with the vertical~~ the transversal position of the vehicle's point of contact with a vertical plane which makes an angle of 60° with the vertical

* In accordance with the programme of work of the Inland Transport Committee for 2012–2016 (ECE/TRANS/224, para. 94 and ECE/TRANS/2012/12, programme activity 02.4), the World Forum will develop, harmonize and update Regulations in order to enhance the performance of vehicles. The present document is submitted in conformity with that mandate.

longitudinal plane of the vehicle and is tangential to the outer surface of the bumper (see Figure 5). corner gauge as defined in Figure 5B.

For determination of the corner of bumper, the front surface of the corner gauge is moved parallel to a vertical plane with an angle of 60° to the vertical longitudinal centre plane of the vehicle (see Figures 5A and 5C) at any height of the centre point of the corner gauge between:

- (a) Equal to and above the point found on the vertical line intersecting the Lower Bumper Reference Line at the assessment position in transversal direction or at 75 mm above the ground reference plane, whichever is higher.
- (b) Equal to and below the point found on the vertical line intersecting the Upper Bumper Reference Line at the assessment position in transversal direction or at 1,003 mm above the ground reference plane, whichever is lower.

For determination of the corner of bumper, the gauge is moved to contact the outer contour/front fascia of the vehicle touching at the vertical centre line of the gauge. The horizontal centre line of the gauge is kept parallel to the ground plane.

The corners of bumper on both sides are subsequently defined as the outermost points of contact of the gauge with the outer contour/front fascia of the vehicle as determined in accordance with this procedure. Any points of contact on the top and the bottom edges of the gauge are not taken into account. The rear and side view mirrors and the tyres shall not be considered."

Figure 5, amend to read:

"Figure 5A

Corner of bumper example (see paragraph 2.17., note that the corner gauge is to be moved in vertical and horizontal directions to enable contact with the outer contour/front fascia of the vehicle)

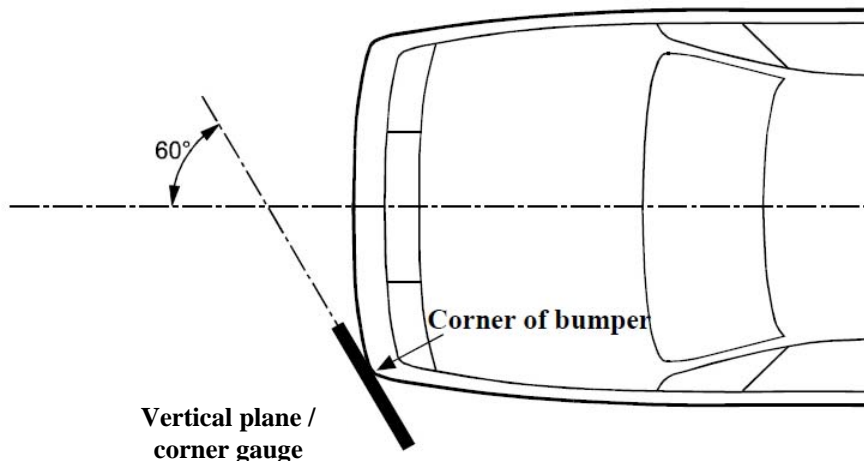
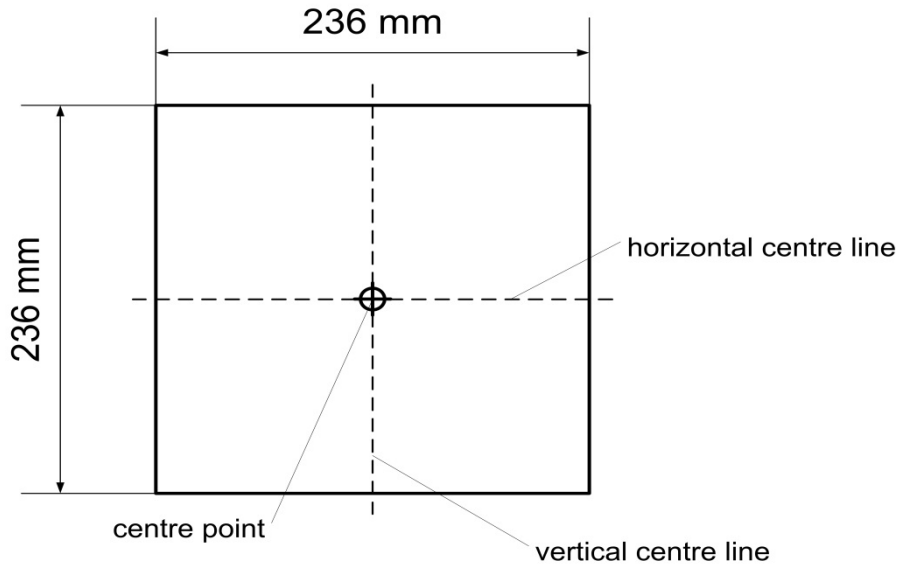

Figure 5B
Corner gauge



The front surface of the corner gauge is flat.

The centre point is the intersection of the vertical and horizontal centre lines on the front surface.

Figure 5C

Determination of the corner of bumper with the corner gauge (shown in random location)

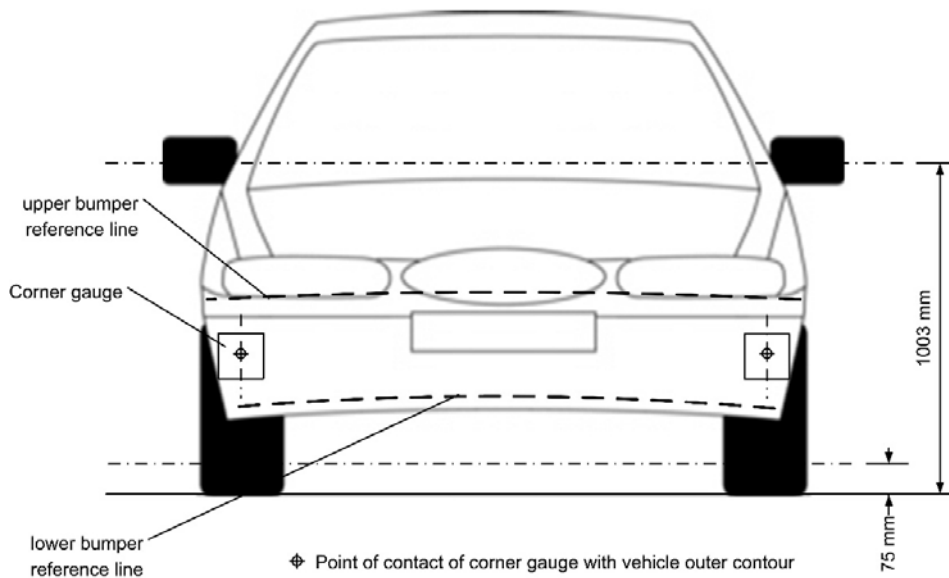
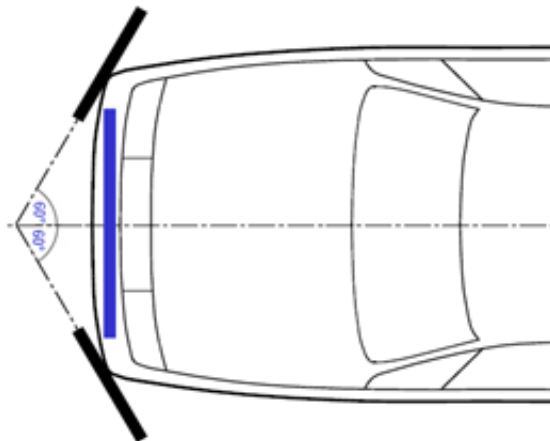

Figure 5D

Determination of bumper test area (note that the corner gauges are to be moved in vertical and horizontal directions to enable contact with the outer contour/front fascia of the vehicle)



Former paragraphs 2.17. to 2.42., renumber as paragraphs 2.18. to 2.43.

Paragraph 4.2., amend to read:

"4.2. An approval number shall be assigned to each type approved; its first two digits (at present 02 corresponding to the 02 series of amendments)... number to another vehicle type."

Paragraphs 11.1. to 11.4., amend to read:

["11.1. As from the official date of entry into force of the **02** series of amendments, no Contracting Party applying this Regulation shall refuse to grant or refuse to accept type approvals under this Regulation as amended by the **02** series of amendments.

11.2. As from 1 September 2019, Contracting Parties applying this Regulation shall grant type approvals only if the vehicle type to be approved meets the requirements of this Regulation as amended by the **02** series of amendments.

11.3. Contracting Parties applying this Regulation shall not refuse to grant extensions of type approvals for existing vehicle types which have been granted according to the ~~preceding~~ **original series of this Regulation or to the 01 series of amendments to this Regulation.**

11.4. Contracting Parties applying this Regulation shall continue to accept type approvals to the ~~preceding~~ **original series of this Regulation and to the 01 series of amendments to the Regulation.**"]

Annex 2, amend to read:

"Annex 2

Arrangements of approval marks

(See paragraphs 4.4. to 4.4.2. of this Regulation)

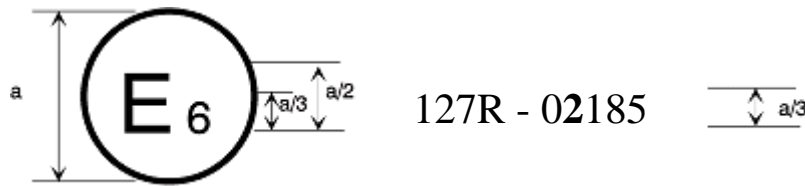

$a = 8 \text{ mm min}$

The above approval mark affixed to a vehicle shows that the vehicle type concerned has been approved in Belgium (E 6) with regard to its pedestrian safety performance pursuant to Regulation No. 127... as amended by the 02series of amendments."

Annex 5, paragraph 1.5., amend to read:

"1.5. A minimum of three lower legform to bumper tests shall be carried out, one each to the middle and the outer thirds of the bumper at positions judged to be the most likely to cause injury. Tests shall be to different types of structure, where they vary throughout the area to be assessed. The selected test points shall be a minimum of ~~132~~ **84** mm apart horizontally, and a minimum of ~~66~~ **42** mm inside the defined corners of the bumper. These minimum distances are to be set with a flexible tape held tautly along the outer surface of the vehicle. The positions tested by the laboratories shall be indicated in the test report."

II. Justification

1. Research showed a need to revise the procedure for determining the bumper test area. The current provisions allow the area to be narrower than intended in the legislative provisions.
2. The TF-BTA held several meetings to assess the raised issue.
3. Findings show a probability that the cost/effectiveness as determined by legislators is negatively affected by the indicated shortcomings.
4. Detailed accident data give evidence of an equal distribution of first pedestrian contact at the front of passenger cars in crashes with at least one injury suffered from contact with a part of the vehicle front end.
5. For the bumper test area, the left and right corner of bumper are first determined through a revised method incorporating a corner gauge tracing the external front bumper fascia that determines the most outboard contact points.
6. During testing, injurious points have been found outside test areas defined by measurements dependent on the outer contour, particularly at the ends of the bumper beam when they extend beyond the left and right corner of bumper. For this reason, the entire width of the bumper beam should also be included in the bumper test area in the second step. Lastly, the widest area is selected for assessment.
7. A clearer definition of what is the bumper beam is provided by the Research Council for Automobile Repairs.
8. The margin zone of half the width of the legform is needed to ensure stable measurement results **in the whole bumper test area on angled surfaces. As the bumper beam method is not linked to external fascia and its position/angle, the margin zone is not applied for the latter.**

9. A proposal not including the bumper beam width as part of the test zone was also presented to GRSP at its December 2014 session, but was not endorsed awaiting the present proposal for amendment.
