

**Economic and Social Council**Distr.: General
27 February 2015

Original: English

Economic Commission for Europe

Inland Transport Committee

World Forum for Harmonization of Vehicle Regulations**Working Party on Passive Safety****Fifty-seventh session**

Geneva, 18-22 May 2015

Item 3(a) of the provisional agenda

**Global technical regulation No.9 (Pedestrian safety) – Proposal for
Phase 2 of the global technical regulation****Proposal for amendments to global technical regulation No. 9
(Pedestrian safety)****Submitted by the expert from the European Commission as Chair of
the Task Force on Bumper Test Area within the Informal Working
Group on global technical regulation No. 9, Phase 2***

The text reproduced below was prepared by the experts in the Task Force on Bumper Test Area (TF-BTA) which is a subgroup of the Informal Working Group on global technical regulation No. 9, Phase 2. TF-BTA proposes an amendment to the provisions of the bumper test. This text is based on informal document GRSP-56-39 distributed at and endorsed during the fifty-sixth session of the Working Party on Passive Safety (GRSP)(ECE/TRANS/WP.29/GRSP/56, para. 9). The modifications to the current text of global technical regulation No. 9 are marked in bold for new or strikethrough for deleted characters.

* In accordance with the programme of work of the Inland Transport Committee for 2012–2016 (ECE/TRANS/224, para. 94 and ECE/TRANS/2012/12, programme activity 02.4), the World Forum will develop, harmonize and update Regulations in order to enhance the performance of vehicles. The present document is submitted in conformity with that mandate.

I. Proposal

Part B, Text of the Regulation,

Insert new paragraph 3.9., to read:

"3.9. "Bumper beam" means the structural cross member under the bumper fascia protecting the front of the vehicle. The beam does not include foam, cover support or any pedestrian protection devices."

Former paragraph 3.9., renumber as paragraph 3.10.

Former paragraph 3.10., renumber as paragraph 3.11. and amend to read:

"3.11. "Bumper test area" means the frontal surface of the bumper limited by two longitudinal vertical planes intersecting the corners of the bumper and moved 66 mm parallel and inboard of the corners of the bumpers. either the front vehicle fascia between the left and right corner of bumper as defined in paragraph 3.14., minus the areas covered by the distance of 42 mm inboard of each corner of bumper, with this distance to be set from the most outboard point with a flexible tape held tautly along the outer surface of the vehicle, or the outermost ends of the bumper beam as defined in paragraph 3.9. (see Figure 5D), whichever area is wider."

Former paragraphs 3.11. and 3.12., renumber as paragraphs 3.12. and 3.13.

Former paragraph 3.13., renumber as paragraph 3.14. and amend to read:

"3.14. "Corner of bumper" means the transversal position of the vehicle's point of contact with a vertical plane which makes an angle of 60° with the vertical longitudinal plane of the vehicle and is tangential to the outer surface of the bumper (see Figure 5).corner gauge as defined in Figure 5B.

For determination of the corner of bumper, the front surface of the corner gauge is moved parallel to a vertical plane with an angle of 60° to the vertical longitudinal centre plane of the vehicle (see Figures 5A and 5C) at any height of the centre point of the corner gauge between:

- (a) Equal to and above the point found on the vertical line intersecting the Lower Bumper Reference Line at the assessment position in transversal direction or at 75 mm above the ground reference plane, whichever is higher.**
- (b) Equal to and below the point found on the vertical line intersecting the Upper Bumper Reference Line at the assessment position in transversal direction or at 1,003 mm above the ground reference plane, whichever is lower.**

For determination of the corner of bumper, the gauge is moved to contact the outer contour/front fascia of the vehicle touching at the vertical centre line of the gauge. The horizontal centre line of the gauge is kept parallel to the ground plane.

The corners of bumper on both sides are subsequently defined as the outermost points of contact of the gauge with the outer contour/front fascia of the vehicle as determined in accordance with this procedure. Any points of contact on the top and the bottom edges of the gauge are not taken into account. The rear and side view mirrors and the tyres shall not be considered."

Figure 5, amend to read:

"Figure 5A

Corner of bumper example (see paragraph 3.14., note that the corner gauge is to be moved in vertical and horizontal directions to enable contact with the outer contour/ front fascia of the vehicle)

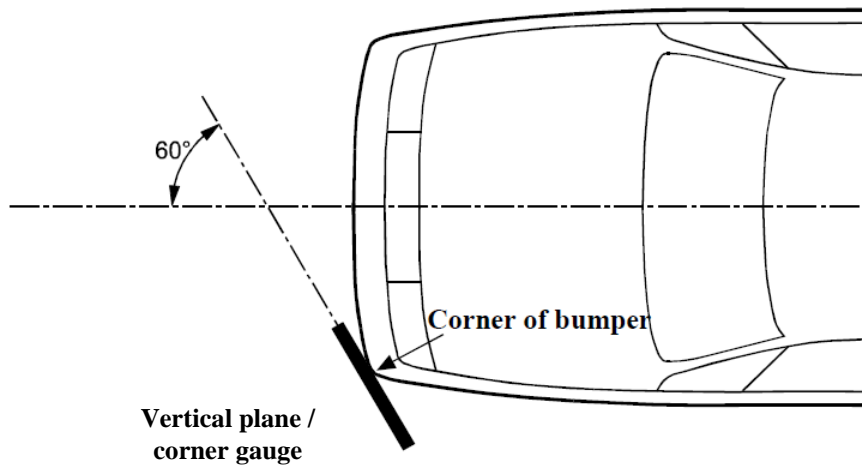
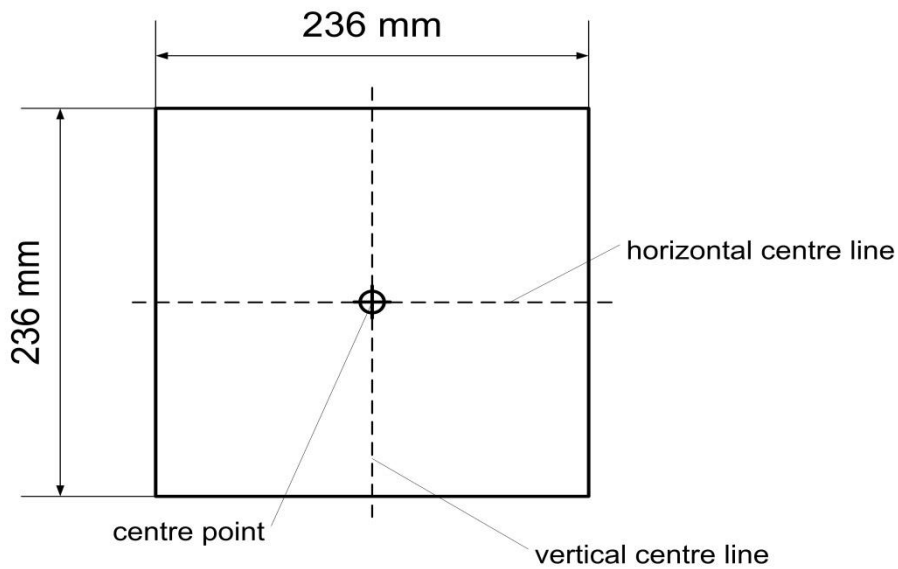

Figure 5B

Corner gauge



The front surface of the corner gauge is flat.

The centre point is the intersection of the vertical and horizontal centre lines on the front surface.

Figure 5C
Determination of the corner of bumper with the corner gauge (shown in random location)

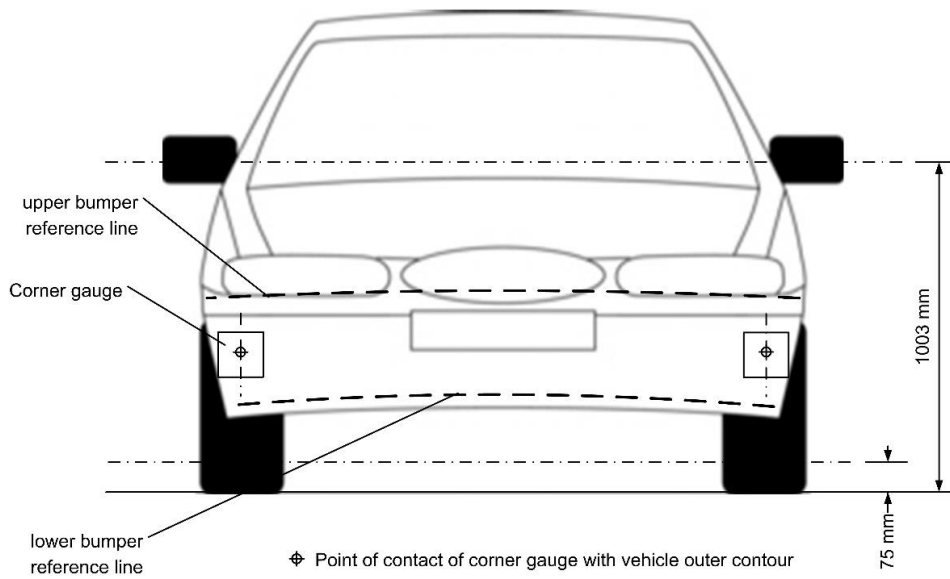
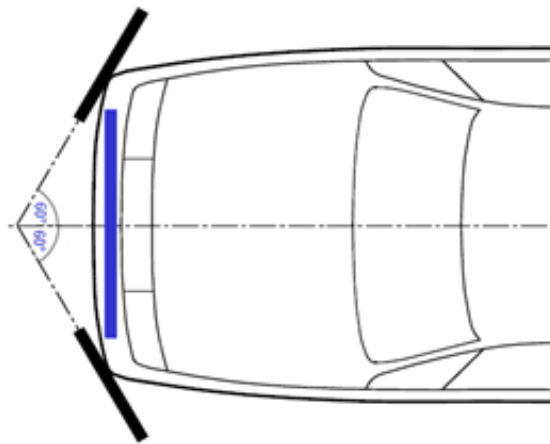

Figure 5D
Determination of bumper test area (note that the corner gauges are to be moved in vertical and horizontal directions to enable contact with the outer contour/front fascia of the vehicle)



Former paragraphs 3.14. to 3.29., renumber as paragraphs 3.15. to 3.30.

II. Justification

1. Research showed a need to revise the procedure for determining the bumper test area. The current provisions allow the area to be narrower than intended in the legislative provisions.
 2. The TF-BTA held several meetings to assess the raised issue.
 3. Findings show a probability that the cost/effectiveness as determined by legislators is negatively affected by the indicated shortcomings.
 4. Detailed accident data give evidence of an equal distribution of first pedestrian contact at the front of passenger cars in crashes with at least one injury suffered from contact with a part of the vehicle front end.
 5. For the bumper test area, the left and right corner of bumper are first determined through a revised method incorporating a corner gauge tracing the external front bumper fascia that determines the most outboard contact points.
 6. During testing injurious points have been found outside test areas defined by measurements dependent on the outer contour, particularly at the ends of the bumper beam when they extend beyond the left and right corner of bumper. For this reason, the entire width of the bumper beam should also be included in the bumper test area in the second step. Lastly, the widest area is selected for assessment.
 7. A clearer definition of what is the bumper beam is provided by the Research Council for Automobile Repairs.
 8. The margin zone of half the width of the legform is needed to ensure stable measurement results on angled surfaces. As the bumper beam method is not linked to external fascia and its position/angle, the margin zone is not applied for the latter.
 9. A proposal not including the bumper beam width as part of the test zone was also presented to GRSP at its December 2014 session, but was not endorsed awaiting the present proposal for amendment.
-