

**Economic and Social Council**Distr.: General
18 July 2014

Original: English

Economic Commission for Europe**Inland Transport Committee****World Forum for Harmonization of Vehicle Regulations****Working Party on General Safety Provisions****107th session**

Geneva, 30 September–3 October 2014

Item 5 of the provisional agenda

Regulation No. 43 (Safety glazing)**Proposal for Supplement 3 to the 01 series of amendments to Regulation No. 43 (Safety glazing)****Submitted by the expert from Germany ***

The text reproduced below was prepared by the expert from Germany on behalf of the Informal Group on Plastic Glazing (IGPG) developing new positions for windscreens and laminated plastic panes other than windscreens. It is based on informal document GRSG-106-16 (see report ECE/TRANS/WP.29/GRSG/85, para. 16). The modifications to the current text of UN Regulation No. 43 are marked in bold for new or strikethrough for deleted characters.

* In accordance with the programme of work of the Inland Transport Committee for 2012–2016 (ECE/TRANS/224, para. 94 and ECE/TRANS/2012/12, programme activity 02.4), the World Forum will develop, harmonize and update Regulations in order to enhance the performance of vehicles. The present document is submitted in conformity with that mandate.

I. Proposal

Contents, insert new Annexes 17, 18 and 19, to read:

"Annex 17 Rigid plastic windscreens

Annex 18 Laminated rigid plastic panes

Annex 19 Laminated rigid plastic windscreens"

Annexes 17 to 21 (former), renumber as Annexes 20 to 24

The text of the Regulation,

Insert new paragraphs 2.6.3. and 2.6.4., to read:

"2.6.3. "Laminated – rigid plastic pane" means a plastic pane consisting of two or more layers of plastic held together by one or more interlayers of plastic material.

2.6.4. "Laminated – rigid plastic windscreen" means a plastic windscreen consisting of two or more layers of plastic held together by one or more interlayers of plastic material."

Paragraph 2.18., replace the reference to "Annex 17" by "Annex 20".

Paragraph 2.19., amend to read:

"2.19. "Type of safety glazing material" means a glazing as defined in paragraphs 2.1. to 2.7. not exhibiting any essential differences, with respect, in particular, to the principal and secondary characteristics defined in Annexes 4 to 12 and 14 ~~to 16~~ to 19;"

Paragraph 2.26., replace the reference to "Annex 18" by "Annex 21".

Paragraph 5.2., amend to read:

"5.2. An approval number shall be assigned to each type as defined in Annexes 5, 7, 11, 12, 14, 15 ~~and~~, 16 **and 18 or, in the case of windscreens, to each group ..."**

Paragraph 5.5.5., amend to read in /L and /M:

"5.5.5. VIII in the case ...

...

/L For panes with a light scatter not exceeding 2 per cent after 1,000 cycles on the outer surface and 4 per cent after 100 cycles on the inner surface (see Annexes 14 ~~and~~, 16 **and 18, paragraph 6.1.3.1.).**

/M For panes with a light scatter not exceeding 10 per cent after 500 cycles on the outer surface and 4 per cent after 100 cycles on the inner surface (see Annexes 14 ~~and~~, 16 **and 18, paragraph 6.1.3.2.)."**

Insert new paragraphs 5.5.11. to 5.5.13., to read:

"5.5.11. XIII in the case of rigid plastic windscreens.

5.5.12. XIV in the case of laminated rigid plastic panes with the signification as described in paragraph 5.5.5.

5.5.13. XV in the case of laminated rigid plastic windscreen."

Paragraph 5.8., replace the reference to "Annex 21" by "Annex 24".

Insert new paragraphs 7.13. to 7.15., to read:

- 7.13. As regards rigid plastic windscreens, the requirements contained in Annex 17.**
- 7.14. As regards laminated rigid plastic panes, the requirements contained in Annex 18.**
- 7.15. As regards laminated rigid plastic windscreens, the requirements contained in Annex 19."**

Paragraph 8.2.1.2., amend to read:

- 8.2.1.2. Plastic glazing materials shall be subjected to the tests listed in the following table. In the case of the abrasion test, the applicant shall have the alternative between the Taber test and the set of three tests composed of the carwash, sand drop and the wiper test.**

Test	Windscreens		Plastics other than windscreens						
	Rigid plastics	Laminated rigid plastics	Rigid plastics		Laminated rigid plastics		Multiple glazing		
	Motorised vehicles		Motorised vehicles	Trailers and unoccupied vehicles	Motorised vehicles	Trailers and unoccupied vehicles	Motorised vehicles	Trailers and unoccupied vehicles	Flexible plastics
Flexibility	A3/12	A3/12	A3/12	A3/12	A3/12	A3/12	A3/12	A3/12	A3/12
227 g ball	A17/5	A19/5.2	A14/5	A14/5	A18/5	A18/5	A16/5	A16/5	A15/4
2260g ball	-	A19/5.1							
Headform ^{1/}	A17/4	A19/4	A14/4	-	A18/4	-	A16/4	-	-
Light transmission ^{2/}	A3/9.1	A3/9.1	A3/9.1	-	A3/9.1	-	A3/9.1	-	A3/9.1
Optical distortion	A3/9.2	A3/9.2	-	-	-	-	-	-	-
Secondary image	A3/9.3	A3/9.3	-	-	-	-	-	-	-
Fire resistance	A3/10	A3/10	A3/10	A3/10	A3/10	A3/10	A3/10	A3/10	A3/10
Chemical resistance	A3/11	A3/11	A3/11.2.1.	A3/11	A3/11	A3/11	A3/11	A3/11	A3/11.2.1.
Abrasion ^{3/}	A17/6.1	A19/6.1	A14/6.1	-	A18/6.1	-	A16/6.1	-	A16/6.1
Weathering	A3/6.4	A3/6.4	A3/6.4	A3/6.4	A3/6.4	A3/6.4	A3/6.4	A3/6.4	A3/6.4
Humidity	A17/6.4	A19/6.4	A14/6.4	A14/6.4	A18/6.4	A18/6.4	A16/6.4	A16/6.4	-
Cross-cut ^{2/}	A3/13	A3/13	A3/13	-	A3/13	-	A3/13	-	-
High temperature	-	A3/5	-	-	A3/5	-	-	-	-
Radiation resistance	-	A3/6	-	-	A3/6	-	-	-	-
Resistance to temperature changes	-	A3/8	-	-	-	-	-	-	-

^{1/} Test requirements are dependent on the location of the glazing within the vehicle.

^{2/} Applies only if the glazing is to be used in a location requisite for driving visibility.

^{3/} Either Taber test or **the set of** sand drop, carwash and wiper test ."

Paragraph 10.2., replace reference to "Annex 20" by "Annex 23".

Annex 1, Paragraph 2., amend to read:

"2. Description of the type of glazing: please refer to Appendices 1, 2, 3, 4, 5, 6, 7, 8 ~~and 9, 10, 11 and 12~~ 2/, and in the case of windscreens, the list conforming to ~~Appendix 10~~ **Appendix 13.**"

Appendices 1, 2, 3 and 5, the bottom line, replace the reference to "Appendix 10" by "Appendix 13".

Insert new Appendices 10, 11 and 12, to read:

"Annex 1 – Appendix 10

Rigid plastic windscreens

(Principal and secondary characteristics as defined in Annex 17 to Regulation No. 43)

Approval No. Extension No.

Principal characteristics:

The chemical designation of the material

Classification of the material by the manufacturer

Nominal thickness

Process of manufacture

Shape and dimensions

Colouring of the plastic product

Nature of the surface coating

Secondary characteristics:

Conductors incorporated (yes/no)

Obscuration incorporated (yes/no)

Remarks

Documents attached: list of windscreens (see Appendix 13)

Annex 1 – Appendix 11

Laminated rigid plastic panes

(Principal and secondary characteristics as defined in Annex 18 to Regulation No. 43)

Approval No. Extension No.

Principal characteristics:

Number of layers of plastic

Number of layers of interlayer

- Nominal thickness
- Nominal thickness of interlayer (s).....
- Nature and type of interlayer (s)
- Special treatment of plastic
- Colouring of plastic product
- Chemical designation of single sheet material
- Classification of the material
- Process of manufacture
- Shape and dimensions
- Nature of the surface coating
- Secondary characteristics:**
- Colouring of interlayer (total/partial)
- Conductors incorporated (yes/no)
- Opaque obscuration incorporated (yes/no)
- Remarks"**

Annex 1 – Appendix 12

Laminated rigid plastic windscreens

(Principal and secondary characteristics as defined in Annex 19 to Regulation No. 43)

Approval No. Extension No.

Principal characteristics:

- Number of layers of plastic
- Number of layers of interlayer
- Nominal thickness
- Nominal thickness of interlayer (s).....
- Nature and type of interlayer (s)
- Special treatment of plastic
- Colouring of plastic product
- Chemical designation of single sheet material
- Classification of the material
- Process of manufacture
- Shape and dimensions
- Nature of the surface coating

Secondary characteristics:

- Colouring of interlayer (total/partial)

Conductors incorporated (yes/no)

Opaque obscuration incorporated (yes/no)

Remarks

Documents attached: list of windscreens (see Appendix 13)."

Appendix 10 (former), renumber as "Appendix 13" and amend to read:

"For each of the windscreens covered ...

...

R-point coordinates (A, B, C) relative to the center of the upper edge of the windscreen.

Description of the commercially available specific device mentioned in Annex 3, paragraph 4.9.2. (if applicable)

..."

Annex 2, insert the following new paragraphs at the end of the Annex:

"Rigid plastic windscreens

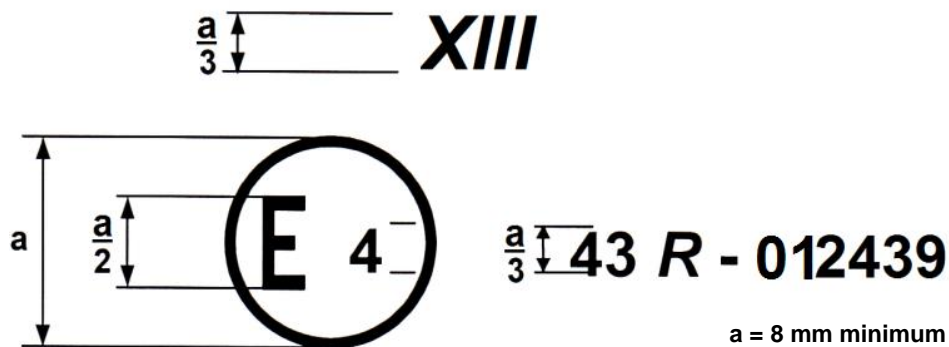

The above approval mark affixed to a rigid plastic windscreen shows that the component concerned has been approved in the Netherlands (E 4) pursuant to Regulation No. 43 under approval No. 012439. The approval number indicates that the approval was granted in accordance with the requirements of Regulation No. 43, as amended by the 01 series of amendments.

Laminated rigid plastic panes

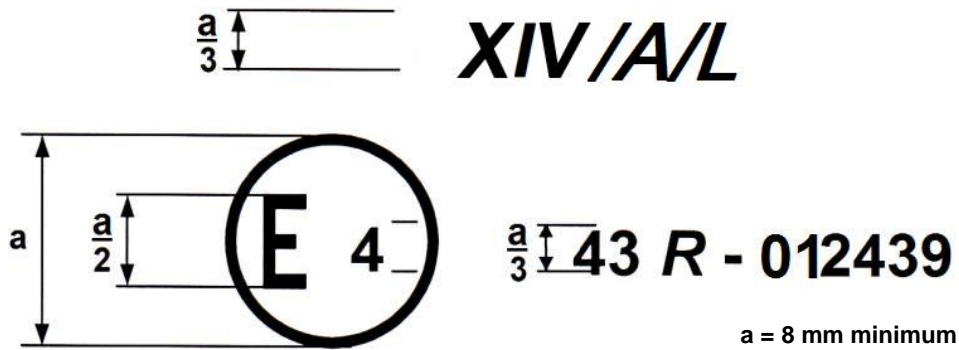

The above approval mark affixed to a laminated rigid plastic glazing pane for forward facing panels with a light scatter not exceeding 2 per cent after 1,000 cycles (in case of Taber test) on the outer surface and 4 per cent after 100 cycles on the inner surface shows that the component concerned has been approved in the Netherlands (E 4) pursuant to Regulation No. 43 under approval No. 012439. The approval number indicates that the approval was granted in accordance with the requirements of Regulation No. 43, as amended by the 01 series of amendments.

Laminated rigid plastic windscreens

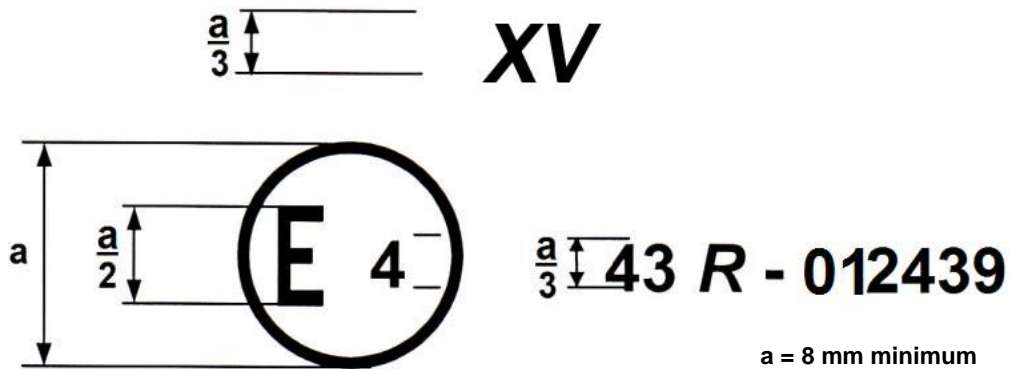

The above approval mark affixed to a laminated rigid plastic windscreen shows that the component concerned has been approved in the Netherlands (E 4) pursuant to Regulation No. 43 under approval No. 012439. The approval number indicates that the approval was granted in accordance with the requirements of Regulation No. 43, as amended by the 01 series of amendments."

Annex 3, insert a new paragraph 4.7. (including a new Figure 6), to read:

"4.7. Sand Drop Test

4.7.1. Apparatus

The sand drop test equipment shall consist essentially of that illustrated in Figure 6. The gravity tube consists of three separate rigid polyvinylchloride tubes (PVC hard) of the same diameter, with two polyamide sieves mounted in between. The sieves should have a mesh size of 1.6 mm. The speed of the turntable shall be 250 ± 10 rev/min.

Figure 6
Sand drop equipment

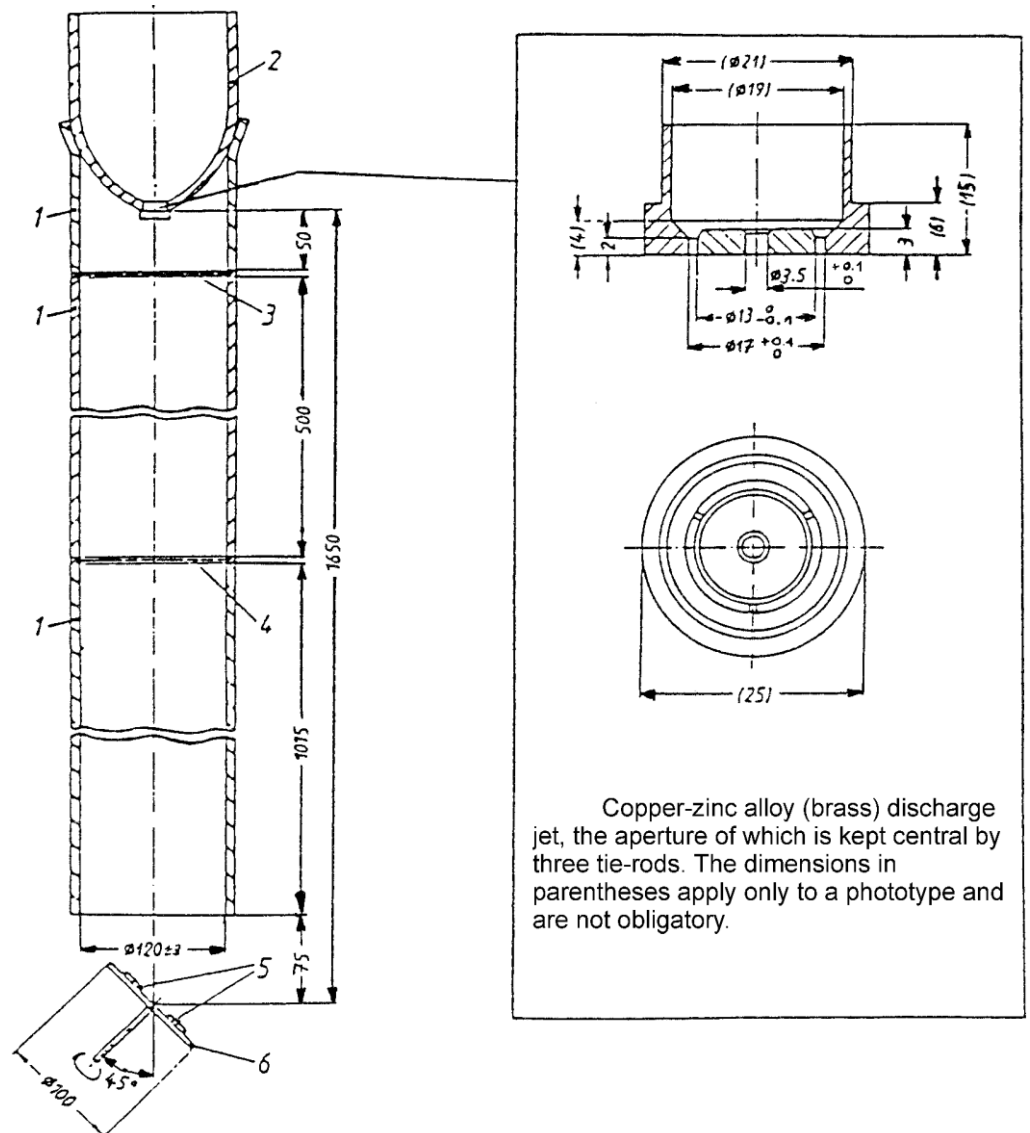

4.7.2. Abrasive material

Natural quartz sand of grain size of 0.50/0.70 mm, with no oversize, obtained by sieving on wire sieves complying with ISO 565 with a mesh size of 0.50 mm and 0.70 mm. The sand may be used up to 10 times.

4.7.3. Test pieces

Three square flat pieces 50 mm x 50 mm of each type shall be taken from the flattest part of the windscreen in the area specified in paragraph 2.2. of Annex 21 (test area A). The test shall be carried out on the face corresponding to the outside of the windscreen.

The test piece shall be conditioned to $(23 \pm 2) ^\circ\text{C}$ and (50 ± 5) per cent relative humidity (rH) for minimum 48 hours and subjected to testing at ambient temperature.

4.7.4. Test procedure

Three kilograms of 0.50/0.70 mm grain size quartz sand shall drop through a gravity tube from a height of 1.650 mm onto the sample to be tested. The test piece and, if necessary, a control-piece shall be mounted on a turntable, the axis of which is a 45° angle to the direction of the sand.

The test pieces shall be mounted on the turntable in such a way that the area to be measured does not extend beyond the turntable. One cycle of 3 kg sand drop shall be performed while the turntable is rotating.

The surface of the test piece shall be washed in water containing 1 per cent detergent and rinsed with distilled or demineralized water, then carefully dried with a grease-free and dust-free linen cloth.

Immediately after drying and before abrasion, the initial haze shall be measured according to Annex 3, paragraph 4.4.3. of this Regulation, and the haze shall be measured again immediately after abrasion. A hazemeter, according to Annex 3, paragraphs 4.1.3. to 4.1.5. of this Regulation, shall be used for measuring the haze."

Annex 3, insert a new paragraph 4.8. (including new Figures 7 to 10), to read:

"4.8. Car Wash Test

4.8.1. Apparatus

The apparatus shall comprise at least the following individual components:

4.8.1.1. Washing brush:

diameter	(1,000 ± 40) mm
width	300 mm
rotation speed	(127 ± 5) rev/min
brush rotation	rotates in the opposite direction relative to the direction of travel of the test panel holder
material	polyethylene
bristle profile	x-shaped, spliced
bristle thickness	(0.8 ± 0.2) mm
bristle length	(440 ± 20) mm visible

penetration depth (100 ± 20) mm (see Figure 7)

The state of the brushes shall be regularly controlled. At least one monitoring of the total amount of operating hours in use for the brush and an automatic replacement of the brush shall be conducted as soon as 30 operating hours are reached (30 hours equates around 300 test runs since one test takes around 6 minutes). The amount of operating hours shall be reported with the haze increase result of the sample.

4.8.1.2. Spray nozzle:

number	2 (spray alternatively and against the direction of travel of the test panel holder)
material	stainless steel
spread of jet	65°
water flow rate	(2.2 ± 0.1) l/min. at (300 ± 50) kPa

The two nozzles shall spray alternately and against the direction of travel of the test panel holder. They shall produce the specified spray pattern (see instrument calibration in Figure 8).

4.8.1.3. Test panel holder

feed speed	(5 ± 0.2) m/min.
------------	------------------

pattern of movement if the brush is rotating clockwise, the right nozzle is spraying and the test panel holder travels from the left side to the right side (and vice versa)

Figure 7

Movement pattern of washing brush and nozzle

Key

- 1 brush
- 2 spray nozzle
- 3 test panel holder
- 4 spray jet (horizontal middle of the jet strikes brush 50 mm above table directly in the brush)
- a penetration depth

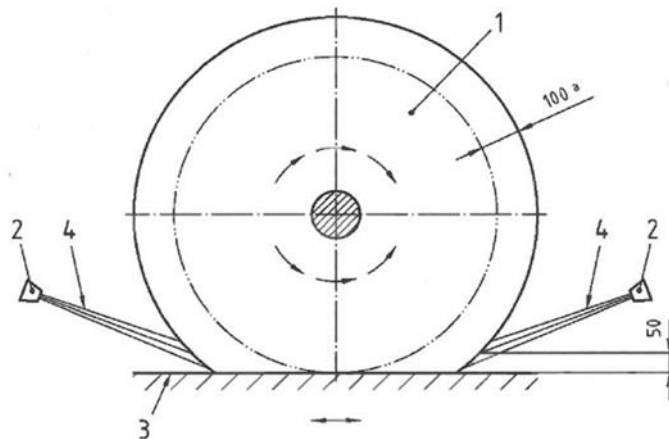

Dimensions in mm

4.8.2. Spray suspension

Prepare a suspension consisting of $(1.5 \pm 0.05 \text{ g})$ of silica powder (silica micro-powder having a mean particle size of $24 \mu\text{m}$) per litre of tap water in a container, stirring vigorously. The water temperature shall be between $15 \text{ }^\circ\text{C}$ and $30 \text{ }^\circ\text{C}$. The suspension shall be stirred continuously during the test procedure in such a way that the silica powder does not settle on the bottom of the container.

4.8.3. Test samples

The size of the samples shall be $50 \text{ mm} \times 100 \text{ mm}$.

Prior to testing the samples shall be conditioned for at least 48 hours at an ambient temperature $(23 \text{ }^\circ\text{C} \pm 2 \text{ }^\circ\text{C})$ and an ambient relative humidity $(50 \text{ per cent} \pm 5 \text{ per cent})$.

4.8.4. Procedure

4.8.4.1. Prearrangements

4.8.4.1.1. The abrasion test shall be carried out at room temperature and only on the outside surface of the plastic safety glazing material.

4.8.4.1.2. Check the state of the polyethylene brushes as described in paragraph 4.8.1.1. of this annex and replace them if they have reached 30 operating hours in total.

4.8.4.1.3. Do the instrument calibration as follows: Set up the equipment as shown in Figure 8. Fill with washing suspension (see paragraph 4.8.2. of this annex and wet the brush sufficiently. Determine the flow rate of the water, $(2.2 \pm 0.1) \text{ l/min.}$, by measurement and adjust by altering the pressure, $(300 \pm 50) \text{ kPa}$. Check the spray pattern of the nozzles (see Figure 9) If the spray pattern cannot be achieved or if the pressure regulation exceeds the tolerances, check, and if necessary replace, the nozzles.

Figure 8
Calibration arrangement

Key:

- 1 brush
- 2 spray nozzle
- 3 test panel holder
- 4 spray jet
- 5 sheet of cardboard

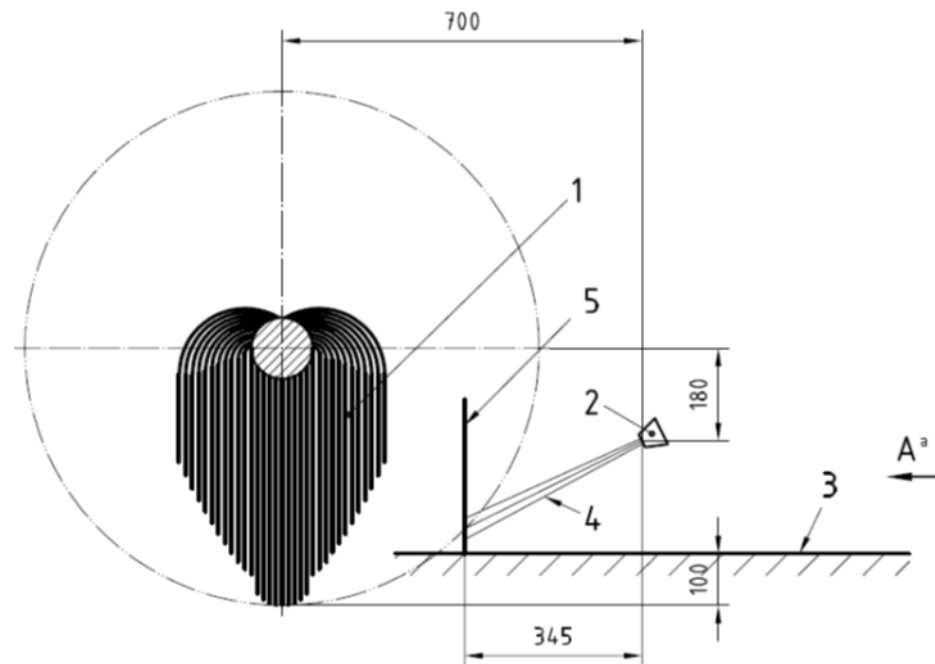

Dimensions in mm

Figure 9
View A of spray pattern

Key:

- 1 sheet of cardboard
- 2 spray pattern

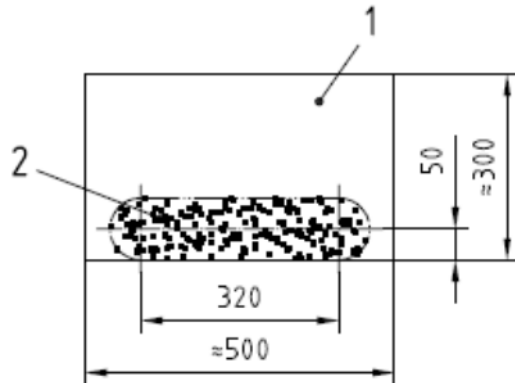

Dimensions in mm

Furthermore perform a trial run without a test panel, carrying out 10 washing operations (10 double passes), to distribute the suspension evenly in the apparatus.

Determine the initial haze of the sample as in Annex 3, paragraph 4.4.3. of this Regulation.

4.8.4.2. Test

- 4.8.4.2.1. Affix the samples with the outside surface face up onto a supporting plate by using a double-faced adhesive tape (Sample positioning on the test holder as shown in Figure 10).

Figure 10
Description of sample positioning on the test panel holder

Key:

- 1 test panel holder movement
- 2 supporting plate 150 mm x 300 mm
- 3 available positions for the samples (50 mm x 100 mm) within the test area
- 4 example for positioning the three different sample types in the test area
- 5 no sample in this area (at least 50 mm at the start and finish of the test panel holder and at least 30 mm edgewise to the direction of travel of the test panel holder)

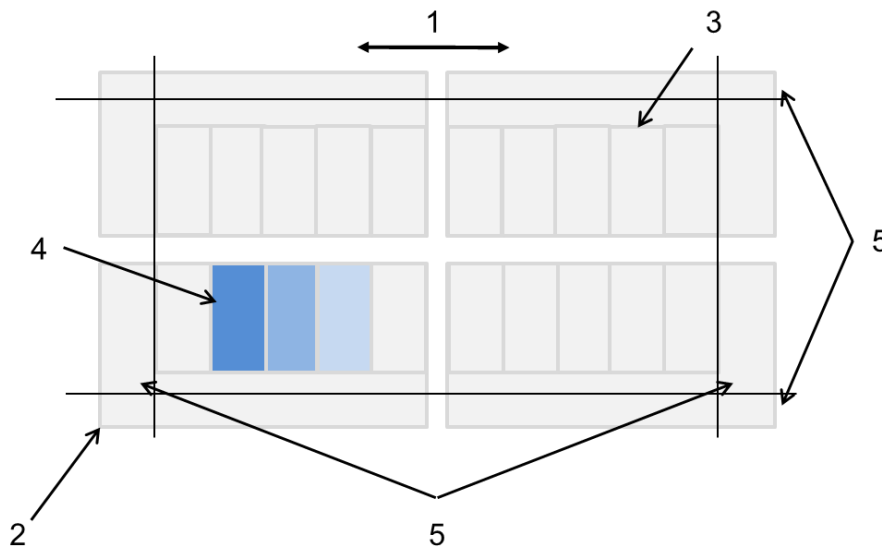

4.8.4.2.2. An area of at least 50 mm at the start and finish of the test panel holder and of at least 30 mm edgewise to the direction of travel of the test panel holder may not be used as testing area for the test specimen.

4.8.4.2.3. Carry out 10 washing operations (10 double passes) using the to-and-fro pattern of movement. Rinse the washed test samples after removing the adhesive tape with cold water, and then clean it with a suitable solvent, e.g. Isopropyl alcohol (IPA), using soft, non-scratching paper tissues and wiping in the direction of the scratches. Finally, leave for 30 minutes to dry off. In case of any inhomogeneous surface appearance of the sample repeat this cleaning process to ensure complete removal of any residue

4.8.4.2.4. After drying, take the final readings of haze, as described in Annex 3, paragraph 4.4.3. of this Regulation, of the test specimens across the direction of scratching.

4.8.4.3. Expression of the results

Subtract the average initial haze from the average total light scattered, the difference representing the light scatter resulting from washing the test specimen. Report this difference for 10 washing operations (10 double strokes) for the outside surface of the test samples. "

Annex 3, insert a new paragraph 4.9. (including new Figures 11 to 16), to read:

"4.9. Wiper laboratory test

Determination of whether a rigid plastic material intended to be used as safety glazing in locations requisite for driver visibility and additionally equipped with a system suitable to wipe the surface has a certain minimum resistance against the action of a wiper including dirt at ambient temperature.

4.9.1. Apparatus

The apparatus¹ is shown schematically in the following figures and includes at least the following individual components:

- 4.9.1.1. A base apparatus with two pillars providing a back and forth linear motion with 37 ± 2 cycles per minute and the possibility to adjust the stroke length (half a wipe cycles) to 130 ± 5 mm, which leads to an average wipe speed of 160 ± 15 mm/s (speed range from 0 (reversal point) to maximal speed (between the two reversal points)),**
- 4.9.1.2. A wiper carriage assembly (see 1 in the Figures 11 and 12) having a beam which spans across the width of the base apparatus and can be mounted at its ends to the pillars, furthermore this carriage assembly has two self-supporting arms (see 2 in the Figures 11 and 12) where a wiper holder can be attached (the distance between the sample surface and bearing of self-supporting arm at the carriage assembly is 100 to 105 mm),**
- 4.9.1.3. A wiper holder² (see 3 in the Figure 11) suitable to attach a normal wiper blade (see 4 in the Figure 11) and adjusted to provide a load of 15 ± 0.5 g/cm (the weight of the wiper blade and its holder together with the wiper blade width determine the wiper load in g/cm),**
- 4.9.1.4. Two sample boxes³ (see 5 in Figure 11 and 12) made out of inert, material in the interior dimension of 200 mm x 120 mm (50 mm height) used to be filled with the aqueous suspension and having a hole at the bottom⁴ where the test sample can be inserted and therefore used as a test sample holder,**
- 4.9.1.5. Different spacer plaques (see 7 in Figure 11) (e.g. made out of the sample box material) in the dimension of the sample but with different thicknesses used to compensate different test sample thicknesses (it is necessary that the bottom surface of the sample box and the sample surface to be tested are on the same height); furthermore care has to be taken to avoid scratching the test sample placed on top of the spacer (e.g. by placing a ultrathin soft film on the surface of the spacer),**

¹ Suitable apparatus are so called scrub resistance tester according to ISO 11998 (wiper carriage assembly according to DIN 53 778).

² For a design drawing see Appendix 1.

³ For a design drawing see Appendix 2.

⁴ The hole shall be in the middle of the bottom plate, slightly larger than the sample dimension of 150 mm to 100 mm has a depth of 10 mm (correlates to thickness of the bottom plate and defines the maximum test sample thickness (10 mm)). Alternatively the box only consists of four walls and does not have a bottom while the test samples are larger and pressed from below against the four walls of the sample box with a good sealing in between.

4.9.1.6. A stainless steel tray (see 11 in the figure 11 and 12),

4.9.1.7. A wipe cycle counter.

Figure 11

Cross-section view of the apparatus

Key

- 1 wiper carriage assembly moving back and forth
- 2 self-supporting arm
- 3 wiper blade holder
- 4 wiper blade
- 5 sample box working as test sample holder and as container for the aqueous suspension
- 6 test sample
- 7 spacer plaque (with a soft masking film on the surface to avoid scratching the sample placed on top of it) to adjust height of the sample to the level of the bottom surface of the sample box
- 8 adhesive tape to fix sample and to seal the gap between sample and its box
- 9 aqueous suspension filled into the box
- 10 adhesive tape⁵ to fix the sample box onto the stainless steel tray
- 11 stainless steel tray

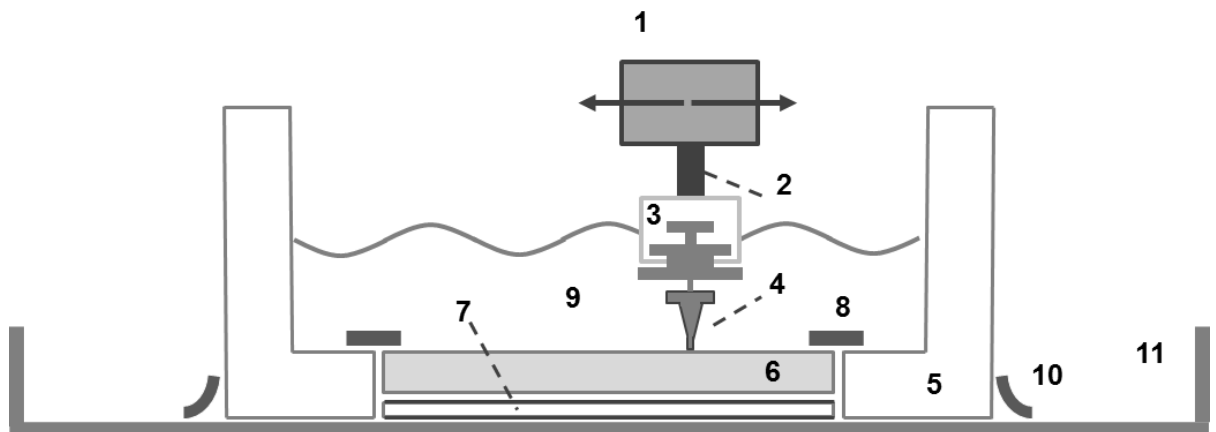

⁵ e.g. a suitable one is Tesa 4668

Figure 12
Bird's-eye view of the apparatus

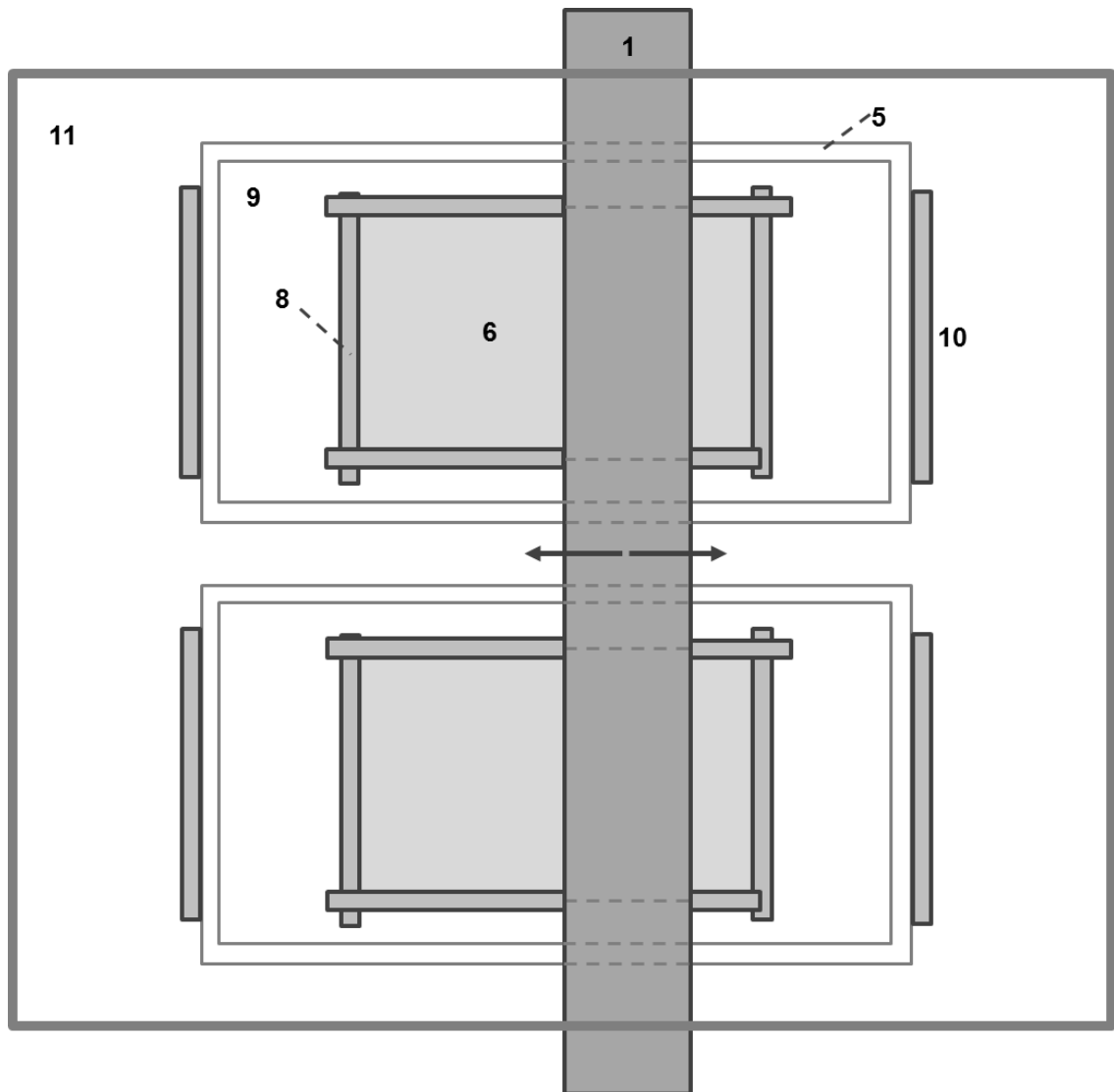

4.9.2. Wiper blade

The wiper used here to test the resistance of rigid plastic safety glazing against wiping with dirt shall be either:

- (a) A normal glass windscreen wiper blade based on chloroprene type rubber (CR grade), chlorinated and with a graphite based anti-friction coating on the surface⁶ in a width of 80 mm or,

⁶ a suitable wiper blade can be e.g. Bosch "H-Stoff P6.3" with a cross profile as shown in Figure 13, or its successor "H-Stoff P32" or equivalent. A complete description of the blade, including its hardness value, its mechanical properties and the composition and thickness of its coating shall be added to the test report.

- (b) A commercially available specific device which is adjusted to the surface characteristics of the rigid plastic glazing and actually intended to be used in the vehicle (e.g. a hydrophobic wiper blade) also in a width of 80 mm. The geometric and chemical characteristics and type of the specific device used for the Type Approval test shall be described in the test report.

In case the specific device has a significantly different cross profile it might be necessary to adapt the wiper blade holder respectively.

A new blade shall be used for every test sample. The wiper blade shall be fixed into the holder as shown below.

Figure 13
Cross profile of the chloroprene type rubber blade

Key

- 1 wiper blade lip (5 mm long)
- 2 wiper blade hinge (0.5 mm width)
- 3 wiper blade heel (5 mm long and used to fix the wiper blade to the wiper blade holder)
- 4 total length of the wiper blade 11 mm
- 5 total width of the wiper blade 9 mm
- 6 groove used to fix the wiper blade to the wiper blade holder (parts below the arrow are outside the wiper blade holder and parts above are within the guide rail of the wiper blade holder)
- 7 Wiper blade extremity (0.6 mm width)

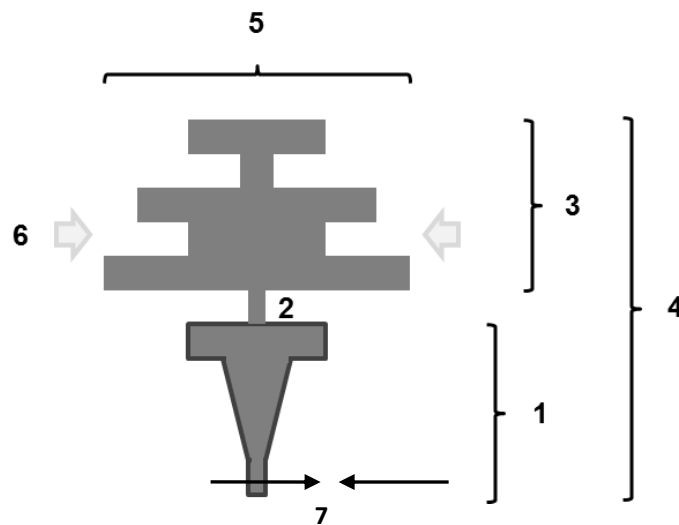

4.9.3. Sample

The size of the absolutely flat test samples shall be 150 mm x 100 mm (slightly larger than the wipe area of 130mm stroke length and 80 mm wiper blade length). The thickness of the test sample shall correspond to the thickness of the rigid plastic glazing part.

4.9.4. Aqueous suspension

The aqueous suspension shall contain:

- (a) 195 ± 1 g water (with a hardness of less than 205 mg/l after evaporation) (97.5 wt.-per cent)
- (b) 5 ± 0.2 g so called ISO test dust A4 (according to ISO 12103-1)⁷ (2.5 wt.-per cent)
- (c) And shall be freshly prepared at room temperature and stirred before use. This amount of aqueous suspension is sufficient for testing one sample and leads to a filling level of around 10 mm in the sample box. A new aqueous suspension shall be used for every test.

4.9.5. Procedure**4.9.5.1. Sample pre-treatment**

Before testing the samples shall be cleaned using a soft cloth soaked with iso-propanol followed by deionized water and drying. After cleaning the samples shall be conditioned for at least 24 hours at $23 \text{ }^\circ\text{C} \pm 2 \text{ }^\circ\text{C}$ and (50 ± 5) per cent relative humidity.

The initial haze value according to Annex 3, paragraph 4.4.3. of this Regulation of the test sample is measured at 9 measurement points across the sample (see 4 in Figure 16).

4.9.5.2. Test equipment pre-check**4.9.5.2.1. Before the equipment is used for testing samples the back and forth linear motion of the pillars of the base apparatus shall be checked for being uniform without any disturbance like getting stuck or starting to vibrate.****4.9.5.2.2. Build up the whole instrument including tray, wiper carriage assembly, wiper blade holders and new wiper blades but without sample box and sample (see Figure 14). To do so the two new wiper blades shall be mounted to their respective wiper blade holders and the latter ones shall be fixed to the carriage assembly. Then align using a spirit level the base plate where later the sample box will be placed and the wiper carriage assembly. Check that the distances of the two bearings of both self-supporting arms at the wiper carriage assembly and at the wiper blade holder are identical. Furthermore control visually that the wiper blade rest on the base plate uniformly without losing contact to the base plate at any point of the wiper blade.**

⁷ A suitable method (e.g. shaking the storage vessel) shall be used to homogenize the test dust and ensure that the 5 ± 0.2 g sample has the same type and size distribution than the whole amount

Figure 14
Equipment pre-check

Key

- 1 wiper carriage assembly moving back and forth
- 2 self-supporting arm
- 3 wiper blade holder
- 4 wiper blade
- 11 stainless steel tray

Pre-check

- A align base plate with spirit level
- B align wiper carriage assembly with spirit level
- C check that the bearings of the self-supporting arms have all the same distance
- D control visually that the wiper blade touches the base plate uniformly

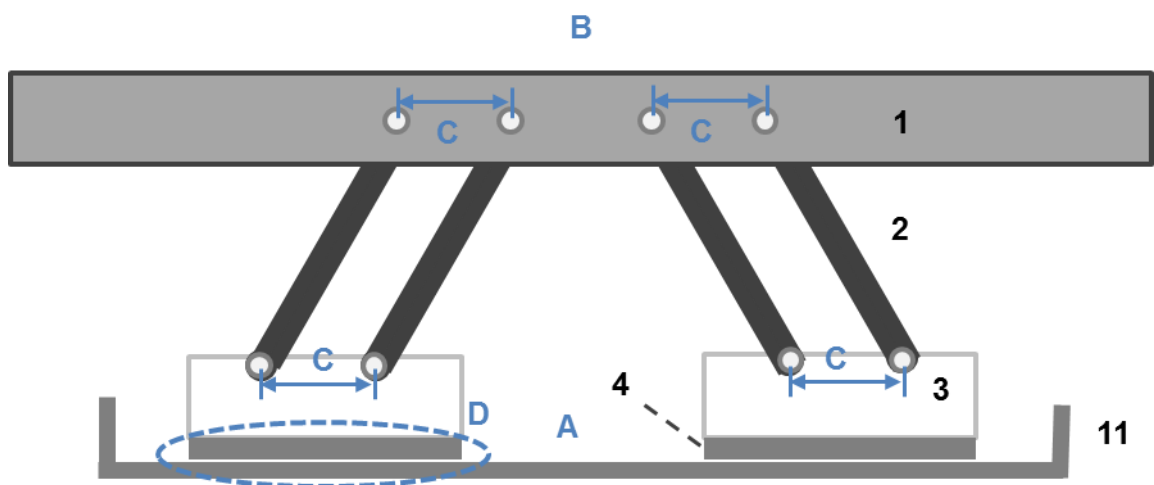

- 4.9.5.2.3. After this pre-check the wiper carriage assemble with the wiper blade holder and the wiper blade shall be removed from the base instrument to allow built up of the sample boxes.
- 4.9.5.2.4. The test shall be carried out under the following conditions: ambient temperature of $20\text{ }^{\circ}\text{C} \pm 5\text{ }^{\circ}\text{C}$, atmospheric pressure of 86 kPa to 106 kPa (860 mbar to 1,060 mbar), and relative humidity of (60 ± 20) per cent.
- 4.9.5.3. Abrasion procedure
- 4.9.5.3.1. With the instrument described above two samples shall be tested in parallel. In case there is only one sample to be tested the second sample box needs to be fitted with a dummy sample.⁸
- 4.9.5.3.2. The sample box shall be placed into the stainless steel tray and fixed using adhesive tape on the two short sides of the box according to Figure B. It is essential that the position of the box leads to a wiping area in exactly the middle of the sample (see 2 in Figure 16). A spacer plaque

⁸ The dummy sample should have a surface characteristic adapted to the surface characteristic of the wiper blade (e.g. both having a hydrophilic or hydrophobic surface) to allow smooth wiping.

adjusted to the thickness of the test sample so that the test sample surface and the bottom surface of the sample box are on the same height (no visible gap in height between sample and bottom surface of the sample box) shall be placed into the hole in the bottom of the sample box.

- 4.9.5.3.3. The sample shall be placed with the to be tested side facing up (representing the outside surface of the plastic glazing part) into the sample holder of the sample box onto the right spacer plaque (which has a soft masking film on its surface to avoid scratching the test samples backside). An adhesive tape shall be used all around the test sample to fix it into the holder and seal the space between sample edge and sample box (to avoid suspension penetrating underneath the sample). The tape shall be used in such a way that the overlay between tape and sample is at maximum 10 mm or in other words in such a way that the wiping area of the sample (see Figure 16) is free of any adhesive tape.
- 4.9.5.3.4. After fixing the sample the carriage assembly including wiper holders and blades from the pre-check shall be mounted to the pillars of the base apparatus. Thereby the wiper blades get into contact with their respective samples. The correct load (15 ± 0.5 g/cm) of the wiper blade onto the sample shall be checked using a spring balance.⁹ Ensure again that the whole equipment (especially test sample, box, and carriage assembly incl. wiper holder and blade) is aligned by using a spirit level.
- 4.9.5.3.5. A freshly prepared suspension shall be filled into each sample box and then the linear back and forth motion of the wiper blade shall be started.
- 4.9.5.3.6. In order to ensure a homogenous abrading it is necessary to follow the action described below:
- 4.9.5.3.6.1. After half of the test cycle numbers [10.000 cycles] the test shall be stopped and the two sample boxes shall be exchanged without turning them (see Figure 15)¹⁰; this leads to an exchange for the two simultaneously tested samples regarding their wiper blades and furthermore alters the alignment of the self-supporting arm carrying the blade (from left to right or the other way round).

⁹ Spring balance force: $1,177 \pm 39$ mN since the wiper blade is 80 mm long; the weight of the wiper blade holder including wiper blade and contributions of the cantilever arm (only ideally weightless) is 120 ± 4 g

¹⁰ Furthermore it is advisable to check if it is necessary to clean the wiper carriage assembly at that stage by disassembling and rinsing with water

Figure 15

Rearrangement of the sample boxes

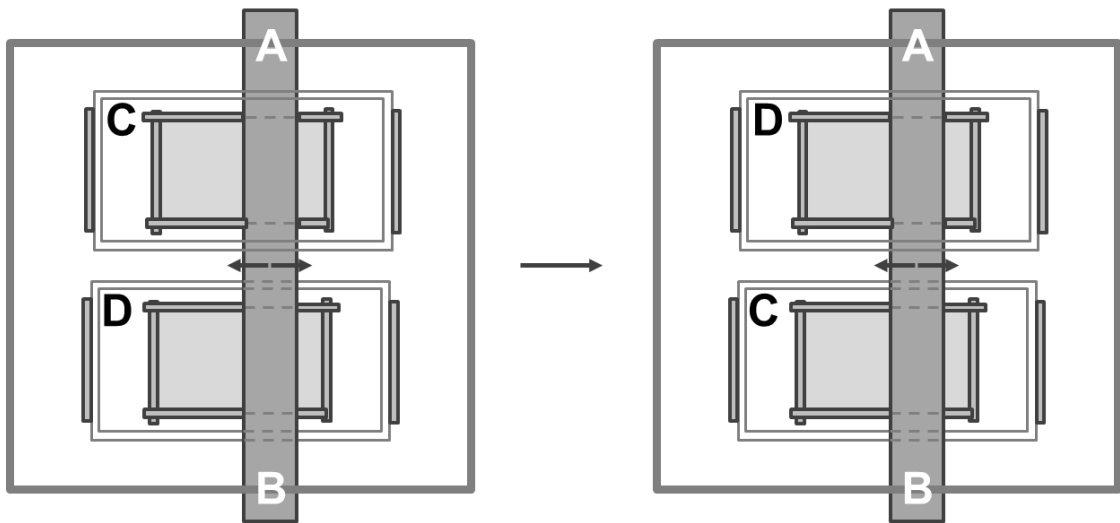

4.9.5.4. Sample treatment after abrasion

4.9.5.4.1. When the abrasion test is finished after [20.000] wipe cycles the suspension shall be drained and the abraded test samples shall be removed and cleaned using a multistep process including:

- (a) Washing with running water,
- (b) Drying,
- (c) Wiping with an iso-propanol soaked soft cloth,
- (d) Followed by deionized water, and
- (e) Drying.

4.9.5.4.2. After cleaning the abraded test samples shall be checked for visible chatter marks as this indicates a none uniform movement of the wiper during the abrasion test. In case of visible chatter marks this sample shall be discarded from further investigation and a retest with a new test sample needs to be done.

4.9.5.4.3. The samples without chatter marks shall be conditioned for at least 24 hours at $23\text{ }^{\circ}\text{C} \pm 2\text{ }^{\circ}\text{C}$ and (50 ± 5) per cent relative humidity. The final haze value according to this regulation of the test samples shall be measured within the middle of the samples (area of 75 mm x 60 mm). The area at the edges of the sample - 20 mm from the long edges and 37.5 mm from the short edges - shall be excluded from the optical measurement. These areas include the reversal point of the wiper blade and the two ends of the wiper blade, where localized different abrasion conditions could exist compared to the middle of the test sample.

4.9.5.4.4. Nine measurement points according to the Figure 16 below shall be used to determine the delta haze at these points and calculate an average delta haze afterwards.

Figure 16

Measurement points across the sample

Key

- 1 sample (150 mm x 100 mm)
- 2 wiping area on the sample (130 mm x 80 mm)
- 3 measurement area on the sample (75 mm x 60 mm)
- 4 locations of the 9 reading areas of the haze measurement (including coordinates of the centre of the area)

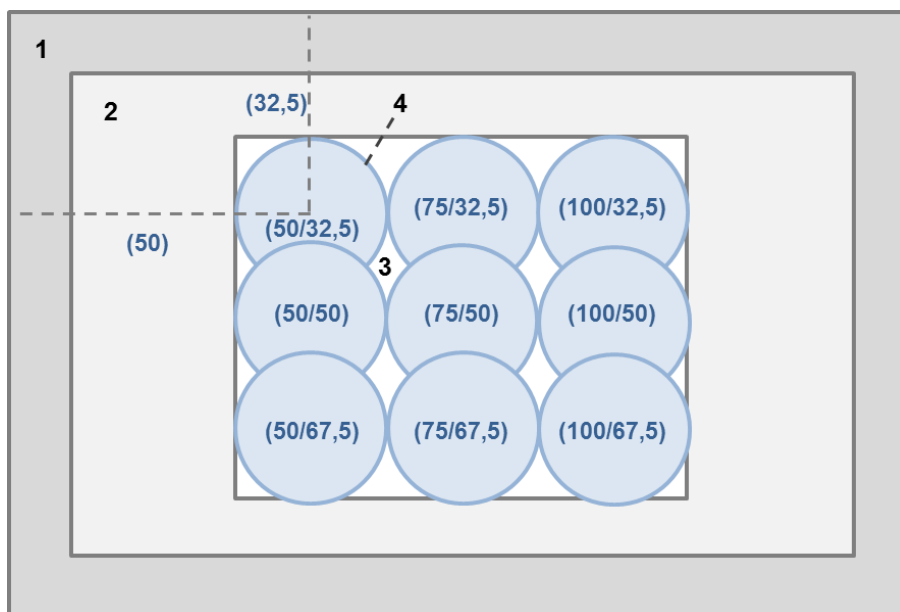

4.9.6. Expression of results

Subtract the initial haze from the final haze for every measurement point, the difference representing the so-called delta haze. Calculate out of these values for the individual measurement points the average delta haze (including standard deviation) resulting from abrasion action of aqueous dirt wiped for [20,000] cycles on the sample surface by a to be reported wiper blade type. "

Annex 3, re-number the subsequent figures accordingly.

Annex 3, paragraph 9.1.2.2., replace the reference to "Annex 18" by "Annex 21".

Annex 3, paragraph 9.1.4., replace the reference to "Annex 21" by "Annex 24".

Annex 3, paragraph 9.2.2.1., replace the reference to "Annex 18" by "Annex 21".

Annex 3, paragraph 9.2.6., in the first row of the table, replace the reference to "Annex 18" by "Annex 21".

Annex 3, paragraph 9.2.6.5., replace the reference to "Annex 18" by "Annex 21".

Annex 3, paragraph 9.3.5., in the first row of the table, replace the reference to "Annex 18" by "Annex 21".

Annex 3, paragraph 9.3.5.5., replace the reference to "Annex 18" by "Annex 21".

Annex 3, paragraph 11.2.4.1., amend to read:

"11.2.4.1. **The chemicals shall be applied to the side of the test piece which represents the outside face of the windscreen or safety glazing pane when mounted on the vehicle while this side is under tensile stress.**

The sample shall be simply supported as a horizontal level arm between a fixed supporting edge at one end in such a way that the entire width will rest on a cutting edge (fulcrum) which is 51 mm from the fixed end support. A load shall be suspended from the free end of the test specimen at a distance of 102 mm from the fulcrum as shown in Figure 21 below:

..."

Annex 3, insert new Appendix 1, to read:

"Annex 3 - Appendix 1

Design Drawing of the Wiper Blade Holder

Figure 1

Cross-cut view of the wiper blade holder with the support plate (left side) and the clamping plate (right side)

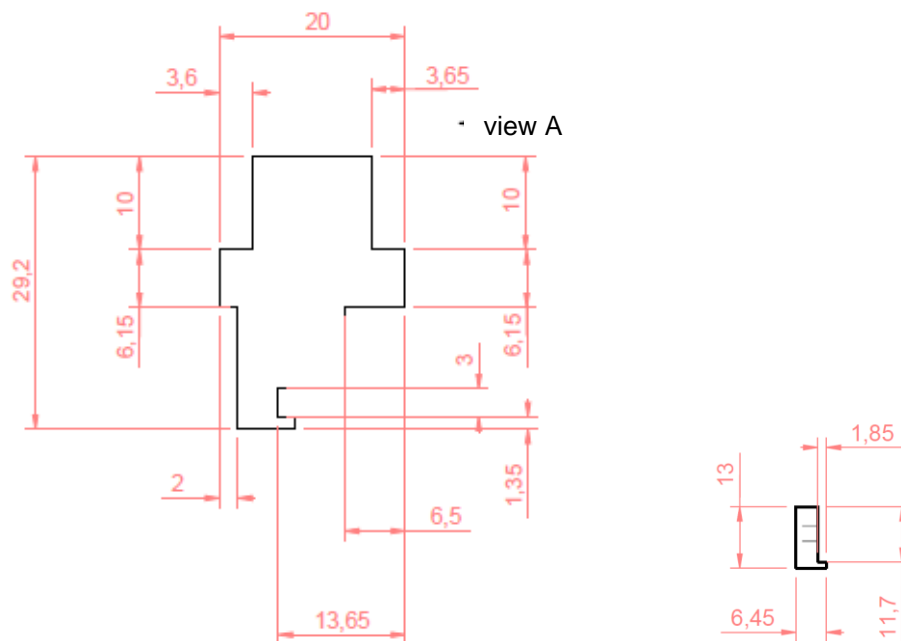

Figure 2
Side view of the support plate (left side) and the clamping plate (right side)

view from direction A

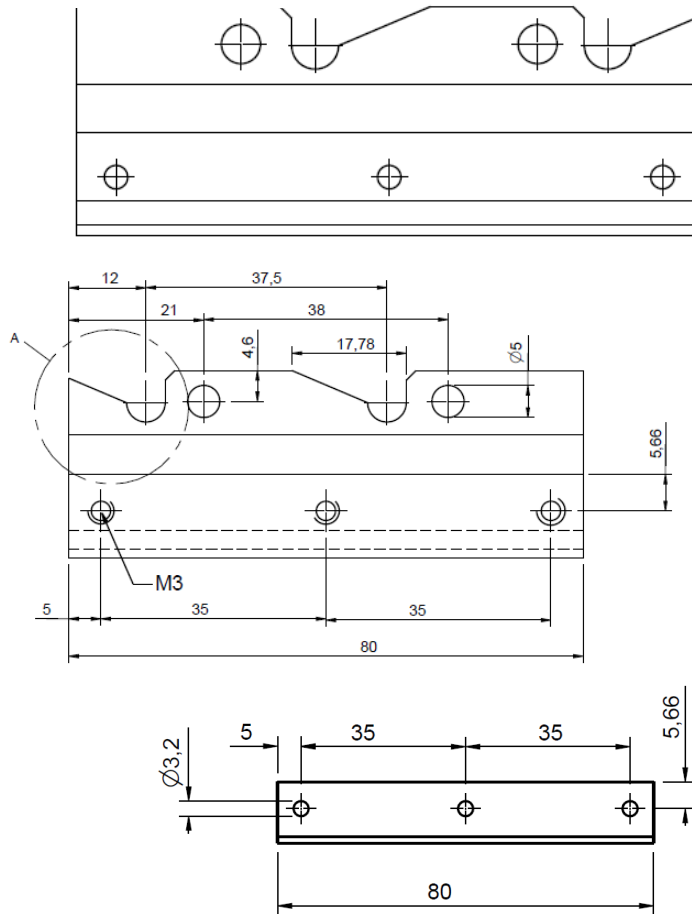
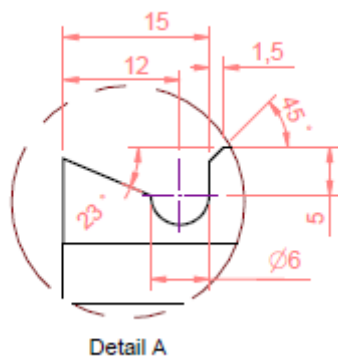
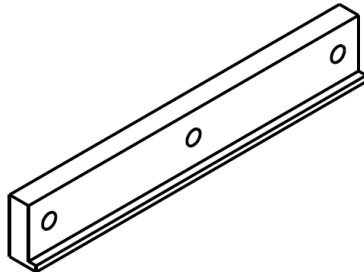

Figure 3
Details regarding the area A in figure 2



area A

Figure 4
3-D view of the wiper blade holder (after inserting the wiper blade into the support plate, the clamping plate is attached and fixed using three screws)



Annex 3, insert new Appendix 2, to read:

"Annex 3 - Appendix 2

Design Drawing from the Sample Box

Figure 1
Bird's-eye view of the box (dimensions are in mm)

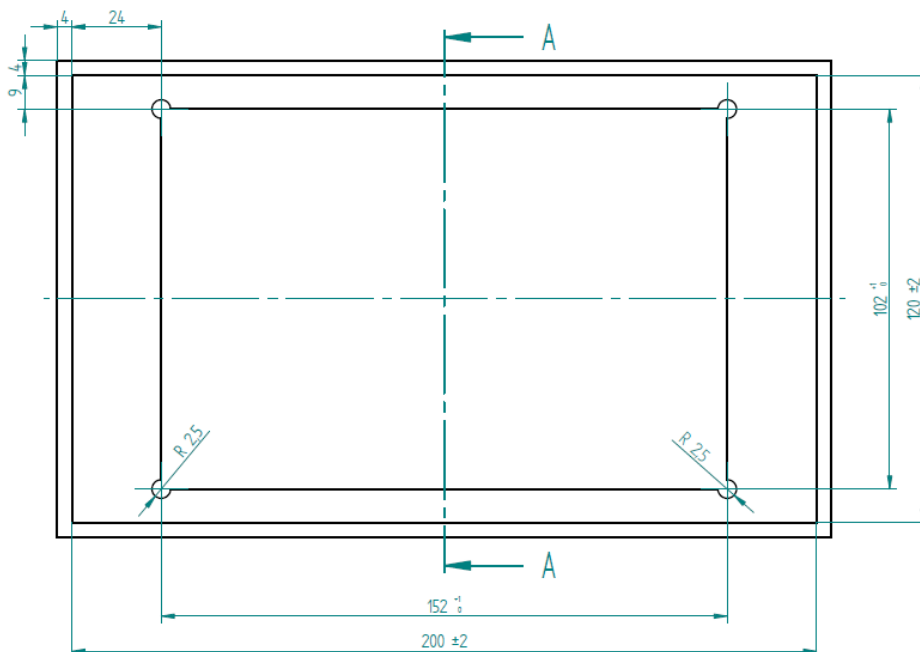

Figure 2
Cross cut view at A

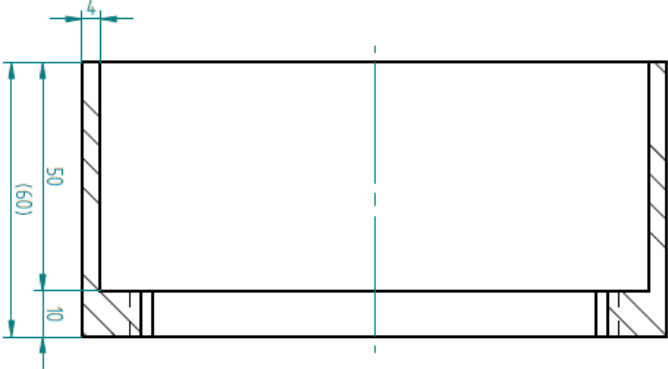
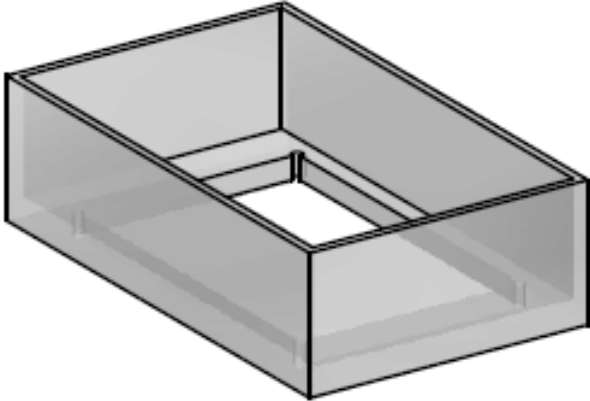

Figure 3
3-D view of the box



Annex 4, paragraph 2.5., replace the reference to "Annex 17" by "Annex 20".

Annex 5, paragraphs 2.5. and 2.5.1., replace all the references to "Annex 17" by "Annex 20".

Annex 13, paragraph 6.1., replace the references to "Annexes 4, 6, 8, 9 and 10" by "Annexes 4, 6, 8, 9, 10, 17 and 19".

Insert new Annexes 17, 18 and 19, to read:

"Annex 17

Rigid plastic windscreens

1. Definition of type

Rigid plastic windscreens shall be deemed to belong to different types if they differ in at least one of the following principal or secondary characteristics.

1.1. The principal characteristics are as follows:

1.1.1. Trade names or marks.

1.1.2. The chemical designation of the material.

1.1.3. The classification of the material by the manufacturer.

1.1.4. The process of manufacture.

1.1.5. The shape and dimensions.

Rigid plastic windscreens shall be deemed to belong to one group for the purposes of tests of mechanical properties and of resistance to the environment.

1.1.6. The nominal thickness. The thickness tolerance limit for extruded plastic products is ± 10 per cent of the nominal thickness. For plastic products produced by other techniques (e.g. cast acrylic sheet), the acceptable thickness tolerance is given by the equation (thickness tolerance limits (mm) = $\pm (0.4 + 0.1 e)$ where e is the nominal thickness in millimetres. Reference Standard is ISO 7823/1.

1.1.7. The colouring of the plastic product.

1.1.8. The nature of the surface coating.

1.2. The secondary characteristics are as follows:

1.2.1. The incorporation or otherwise of conductors.

1.2.2. The incorporation or otherwise of obscuration bands.

2. General

2.1. In the case of rigid plastic windscreens the tests shall be conducted either on flat test pieces rigorously representative of the finished product or on finished parts.

2.2. The test pieces must be freed from protecting masking and have to be cleaned carefully before the test.

2.2.1. They must be stored for 48 hours at a temperature of $23 \text{ }^\circ\text{C} \pm 2 \text{ }^\circ\text{C}$ and a

- relative humidity of 50 per cent \pm 5 per cent.
3. Flexibility test
 - 3.1. Indices of difficulty of the secondary characteristics. No secondary characteristic is involved.
 - 3.2. Number of test pieces

One flat test piece measuring 300 mm x 25 mm shall be subjected to testing.
 - 3.3. Test method
 - 3.3.1. The method used shall be that described in Annex 3, paragraph 12.
 - 3.4. Interpretation of results

For a test piece or sample to be considered rigid the vertical deflection of the test piece shall be less than or equal to 50 mm after 60 seconds.
 4. Headform test on a complete windscreen
 - 4.1. Indices of difficulty of the secondary characteristics: no secondary characteristic is involved.
 - 4.2. Number of windscreens

Six complete windscreens from the smallest-developed-area series and six complete windscreens from the largest-developed-area series selected in accordance with the provisions of Annex 13, shall be tested.
 - 4.3. Test method
 - 4.3.1. The method used shall be that described in Annex 3, paragraph 3.2.
 - 4.3.2. The drop height shall be 3 m. The HIC value is also to be measured.
 - 4.4. Interpretation of results

The test shall be deemed to have given a satisfactory result if the following conditions are fulfilled:

 - 4.4.1. The sample is not penetrated nor shall it break into fully separate large pieces.
 - 4.4.2. The HIC value shall be less than 1,000.
 - 4.4.3. A set of samples submitted for approval shall be considered satisfactory from the point of view of the headform test if all the tests give satisfactory results,
 5. Mechanical strength test – 227 g ball
 - 5.1. Indices of difficulty of the secondary characteristics:
 - (a) Without conductors;
 - (b) With conductors;
 - (c) With and without obscuration.
 - 5.2. Number of test pieces

Ten flat square pieces of 300 +10/-0 mm side or ten substantially flat finished parts shall be subjected to testing. In this later case the contact between the part and the supporting fixture shall be around the whole perimeter and of about 15 mm width. Upper and lower supporting

frames shall be clamped together in a way that ensures that the movement of the test piece during the test shall not exceed 2 mm.

- 5.3. Test method**
- 5.3.1. The method used shall be that prescribed in Annex 3, paragraph 2.1. the height of drop shall be 8.5 m at ambient temperature.**
- 5.4. Interpretation of results**
- 5.4.1. The ball test shall be considered to have given a satisfactory result if the following conditions are met:**
- (a) The ball does not penetrate the test piece**
 - (b) The test piece does not break into separate pieces**
- As a result of the impact, cracks and fissures in the sheet are however permissible.**
- 5.4.2. A set of test pieces submitted for approval shall be considered satisfactory from the point of view of the 227 g ball test if eight or more separate tests give a satisfactory result at the drop height.**
- 5.4.3. The ambient temperature ball drop test shall be only performed after the humidity test of paragraph 6.4.4. of this annex.**
- 5.5. 227 g ball test at $-18\text{ }^{\circ}\text{C} \pm 2\text{ }^{\circ}\text{C}$.**
- 5.5.1. To minimize the temperature change of the test piece, the test shall be performed within 30 seconds of the removal of the test piece from the conditioning appliance.**
- 5.5.2. The test method shall be that described in paragraph 5.3. of this annex, except that the test temperature shall be $-18\text{ }^{\circ}\text{C} \pm 2\text{ }^{\circ}\text{C}$.**
- 5.5.3. Interpretation of results**
- As in paragraph 5.4. of this annex**
- 6. Test of resistance to the environment**
- 6.1. Test of resistance to abrasion**
- For the purpose of testing the resistance to abrasion, either the Taber test or as an equivalent alternative the package of Sand drop test, Car-wash test and Wiper test shall be performed.**
- 6.1.1. Taber test**
- 6.1.1.1. Indices of difficulty and test method**
- The requirements of Annex 3, paragraph 4. shall apply; the test is performed for 1,000 cycles to measure abrasion of the outer surface of the product.**
- 6.1.1.2. Three flat square test pieces of 100 mm for each type of surface shall be subjected to testing.**

- 6.1.1.3. Interpretation of results**
The safety glazing shall be considered satisfactory with respect to abrasion resistance if the increase of haze as a result of abrasion of the test piece does not exceed 2 per cent.
- 6.1.1.4. A set of samples for approval shall be considered satisfactory if all samples meet the requirements.**
- 6.1.2. Sand Drop Test**
- 6.1.2.1. Indices of difficulty and test method**
The requirements of Annex 3, paragraph 4.7. shall apply. Three kilograms of sand shall be used.
- 6.1.2.2. Interpretation of results**
The safety glazing shall be considered satisfactory if the increase of haze as a result of abrasion of the test piece does not exceed 5 per cent.
- 6.1.2.3. A set of samples for approval shall be considered satisfactory if all samples meet the requirements.**
- 6.1.3. Car Wash Test**
- 6.1.3.1. Indices of difficulty and test method**
A car wash equipment as described in paragraph 4.8.1. of Annex 3 to this regulation shall be used. ten washing operations (ten double passes) shall be carried out
- 6.1.3.2. Three flat pieces 50 mm x 100 mm of each type shall be taken from the flattest part of the windscreen in the area specified in paragraph 2.2. of Annex 21 (test area A). The test shall be carried out on the face corresponding to the outside of the windscreen.**
- 6.1.3.3. Interpretation of results**
The safety glazing shall be considered satisfactory if the increase of haze as a result of abrasion of the test piece does not exceed 2 per cent.
- 6.1.3.4. A set of samples for approval shall be considered satisfactory if all samples meet the requirements.**
- 6.1.4. Wiper test**
- 6.1.4.1. Indices of difficulty and test method**
A wiper laboratory equipment as described in paragraph 4.9.1. of Annex 3 to this Regulation shall be used. [20,000] wiper cycles shall be carried out.
- 6.1.4.2. Three absolutely flat test samples of 150 mm x 100 mm shall be tested. The test shall be carried out on the face corresponding to the outside of the windscreen.**
- 6.1.4.3. Interpretation of results**
The safety glazing shall be considered satisfactory if the increase of haze as a result of abrasion of the test piece does not exceed 2 per cent.
- 6.1.4.4. A set of samples for approval shall be considered satisfactory if all samples meet the requirements.**

- 6.2. Test of resistance to simulated weathering**
- 6.2.1. Indices of difficulty and test method**
- The requirements of Annex 3, paragraph 6.4. shall apply. The total ultraviolet radiant exposure with the long arc xenon lamp shall be 500 MJ/m². During irradiation the test pieces shall be exposed to water spray in continuous cycles. During a cycle of 120 minutes the test pieces are exposed to light without water spray for 102 minutes, and to light with water spray for 18 minutes.
- 6.2.1.1. Other methods giving equivalent results shall be allowed.**
- 6.2.2. Number of test pieces**
- Three flat test pieces 130 mm x 40 mm cut from a flat sheet sample shall be subjected to testing.
- 6.2.3. Interpretation of results**
- 6.2.3.1. The resistance to the simulated weathering shall be considered to have given a satisfactory result if:**
- 6.2.3.1.1. The light transmittance measured in accordance with Annex 3, paragraph 9.1. does not fall below 95 per cent of the pre-weathering value. Additionally, the value shall not fall below 70 per cent.**
- 6.2.3.1.2. No bubbles or other visible decompositions, discolourations, milkiness or crazing shall occur during weathering.**
- 6.2.4. A set of test pieces or samples submitted for approval shall be considered satisfactory from the point of view of the resistance to simulated weathering if all test pieces have given a satisfactory result.**
- 6.3. Cross-cut test**
- 6.3.1. Indices of difficulty and test method**
- The requirements of Annex 3, paragraph 13. shall apply only to coated rigid products.
- 6.3.2. The cross-cut test shall be carried out on one of the test pieces from paragraph 6.2.**
- 6.3.3. Interpretation of results**
- 6.3.3.1. The cross-cut test shall be considered to have given a satisfactory result if at least the cross-cut value Gt1 is met.**
- 6.4. Resistance-to-humidity test**
- 6.4.1. Indices of difficulty and test method**
- The requirements of Annex 3, paragraph 7 shall apply.
- 6.4.2. Ten flat square test pieces of 300 mm side or ten test pieces of same size cut from windscreens, or ten original parts shall be subjected to testing.**
- 6.4.3. Interpretation of results**
- 6.4.3.1. The humidity test shall be considered to have given a satisfactory result if:**
- 6.4.3.1.1. No visible decompositions like bubbles or milkiness occur on any sample, and**

- 6.4.3.1.2. The light transmittance measured according to Annex 3, paragraph 9.1. shall not fall to less than 95 per cent of the pre-test value and additionally to no less than 70 per cent, on any sample.
- 6.4.4. After testing the test pieces shall be stored for at least 48 hours at a temperature of $23\text{ }^{\circ}\text{C} \pm 2\text{ }^{\circ}\text{C}$ and a relative humidity of 50 per cent ± 5 per cent, and then subjected to the 227 g ball drop test, under ambient temperature, described under paragraph 5.3. of this annex.
- 6.5. Fire resistance test
 - 6.5.1. Indices of difficulty and test method

The requirements of Annex 3, paragraph 10 shall apply.
 - 6.5.2. Interpretation of results

The fire-resistance test shall be considered to have given a satisfactory result if the burning rate is less than 110 mm/min.
 - 6.5.2.1. For the purpose of approval a set of samples will be considered satisfactory if all samples give a satisfactory result.
- 6.6. Resistance to chemicals
 - 6.6.1. Immersion test
 - 6.6.1.1. Indices of difficulty and test method

The requirements of Annex 3, paragraph 11.2.1. shall apply.
 - 6.6.1.2. Interpretation of results

A set of four samples for each chemical shall be tested; for each chemical, one of these samples shall be cross-cut according to paragraph 13. of Annex 3.

Three samples out of four, among which the cross-cut sample mentioned above, shall give satisfactory results for each chemical.
 - 6.6.2. Test under load
 - 6.6.2.1. Indices of difficulty and test method

The requirements of Annex 3, paragraph 11.2.4. shall apply.
 - 6.6.2.2. Interpretation of results

A set of four samples, not being the ones mentioned in paragraph 6.6.1. above, for each chemical shall be tested.

Three samples out of four shall give satisfactory results for each chemical.
- 7. Optical qualities

The requirements concerning optical qualities set out in Annex 3, paragraph 9. shall apply to every type of windscreen.

 - 7.1. Interpretation of results

A set of 4 samples shall be considered as satisfactory if all samples give satisfactory results.

Annex 18

Laminated rigid plastic panes

1. **Definition of type**

Laminated rigid plastic panes shall be deemed to belong to different types if they differ in at least one of the following principal or secondary characteristics.
- 1.1. **The principal characteristics are as follows:**
 - 1.1.1. **Trade names or marks.**
 - 1.1.2. **The chemical designation of the single sheet material.**
 - 1.1.3. **The classification of the material by the manufacturer.**
 - 1.1.4. **The process of manufacture.**
 - 1.1.5. **The shape and dimensions.**
 - 1.1.6. **The nominal thickness 'e' of the pane, a manufacturing tolerance of $\pm n \cdot x$ mm being allowed ('n' being the number of layers of rigid plastic in the pane and x is the manufacturing tolerance of the single rigid plastic sheets in the pane, its value is depending on the process of manufacture and being given in Annex 14, paragraph 1.1.6.).**
 - 1.1.7. **The nominal thickness of the interlayer or interlayers,**
 - 1.1.8. **The nature and type of the interlayer or interlayers, e.g. PVB or other plastics-material interlayer or interlayers,**
 - 1.1.9. **Any special treatment which one of the layers of plastic may have undergone.**
 - 1.1.10. **The colouring of the plastic product.**
 - 1.1.11. **The nature of the surface coating.**
- 1.2. **The secondary characteristics are as follows:**
 - 1.2.1. **The colouring (total or partial) of the interlayer or interlayers (colourless or tinted).**
 - 1.2.2. **The incorporation or otherwise of opaque obscuration.**
 - 1.2.3. **The presence or absence of conductors or heating elements.**
2. **General**
 - 2.1. **In the case of rigid plastic panes the tests shall be conducted either on flat test pieces rigorously representative of the finished product or on finished parts. All optical measurements shall be carried out on real parts.**
 - 2.2. **The test pieces must be freed from protecting masking and have to be cleaned carefully before the test.**
 - 2.2.1. **They must be stored for 48 hours at a temperature of $23\text{ }^{\circ}\text{C} \pm 2\text{ }^{\circ}\text{C}$ and a relative humidity of 50 per cent ± 5 per cent.**

- 2.3. To describe the breaking behaviour under dynamical stress, classes will be created depending on the application of the plastics. These classes are related to contact probabilities of the human head with the plastic glazing and they contain different requirements concerning the headform test.
3. Flexibility test
- 3.1. Indices of difficulty of the secondary characteristics
No secondary characteristic is involved.
- 3.2. Number of test pieces
One flat test piece measuring 300 mm x 25 mm shall be subjected to testing.
- 3.3. Test method
- 3.3.1. The method used shall be that described in Annex 3, paragraph 12.
- 3.4. Interpretation of results
For a test piece or sample to be considered rigid the vertical deflection of the test piece shall be less than or equal to 50 mm after 60 seconds.
4. Headform test
- 4.1. Indices of difficulty of the secondary characteristics
No secondary characteristic is involved.
- 4.2. Number of test pieces
Six flat test pieces (1,170 mm x 570 mm +0/-2 mm) or six complete parts shall be subjected to testing.
The table below shows the type of samples subject to testing, in accordance with the dimensions of the glazing to be assessed.

<i>Type of window</i>	<i>Characteristic of window</i>	<i>Dimensions of flat sample</i>	<i>Alternative</i>
Small window	Diameter D of the circle capable to be scribed: D < 150 mm	No test	
Other than small window	Diameter D of the circle capable to be scribed: 150 < D < 400 mm	1170 mm x 570 mm (material type testing and standard support frame)	Other part of same material, production procedure, thickness, colour with dimensions bigger than those of the original part, into which a 400 mm diameter circle can be scribed, and with a developed surface area of less than 1,170 mm x 570 mm (part type approval for the original part ¹¹)
	Diameter D of the circle capable to be scribed: 400 mm < D	1170 mm x 570 mm (material type testing and standard support frame)	Real part (submitted for approval) (part type approval and dedicated support frame)

¹¹ Original part dimensions are too small for performing the test.

- 4.3. Test method**
- 4.3.1.** The method used shall be that described in Annex 3, paragraph 3.2.
- 4.3.2.** For forward facing panes situated forward to an occupant and which have impact probability (classification XIV/A) the drop height shall be 3 m. The HIC value shall also be measured.
- 4.3.3.** For side windows, back windows with limited impact possibilities (classification XIV /B) and sunroofs the drop height shall be 1.5 m. The HIC value shall be measured.
- 4.3.4.** For panes which are not likely to be impacted as well as for small windows in motor vehicles and for all windows in trailers (classification XIV/C) the headform shall not be performed. A small window is a window into which a 150 mm diameter circle cannot be scribed.
- 4.4. Interpretation of results**
- The test shall be deemed to have given a satisfactory result if the following conditions are fulfilled:
- 4.4.1.** The test piece or sample is not penetrated nor shall it break into fully separate large pieces.
- 4.4.2.** The HIC value is less than 1,000.
- 4.4.3.** A set of test pieces submitted for approval shall be considered satisfactory from the point of view of the headform test if all the tests give satisfactory results.
- 5. Mechanical strength test – 227 g ball test**
- 5.1. Indices of difficulty of the secondary characteristics:**
- (a) Without conductors, obscuration(s) or heating elements,
- (b) With conductors, obscuration(s) or heating elements.
- 5.2. Number of test pieces**
- Ten flat square pieces of 300 +10/-0 mm side or ten substantially flat finished parts shall be subjected to testing. In this later case the contact between the part and the supporting fixture shall be around the whole perimeter and of about 15 mm width. Upper and lower supporting frames shall be clamped together in a way that ensures that the movement of the test piece during the test shall not exceed 2 mm.
- 5.3. Test method**
- 5.3.1.** The method used shall be that prescribed in Annex 3, paragraph 2.1.
- 5.3.2.** The height of drop shall be 6 m.
- 5.4. Interpretation of results**
- 5.4.1.** The ball test shall be considered to have given a satisfactory result if the following conditions are met:
- (a) The ball does not penetrate the test piece,
- (b) The test piece does not break into separate pieces.
- As a result of the impact, cracks and fissures in the test piece shall however be permitted.

- 5.4.2. A set of test pieces submitted for approval shall be considered satisfactory from the point of view of the 227 g ball test if eight or more separate tests give a satisfactory result at the drop height.
- 5.4.3. The ambient temperature ball drop test shall be only performed after the humidity test of paragraph 6.4.4. of this annex.
- 5.5. 227 g ball test at $-18\text{ }^{\circ}\text{C} \pm 2\text{ }^{\circ}\text{C}$.
- 5.5.1. To minimize the temperature change of the test piece, the test shall be performed within 30 seconds of the removal of the test piece from the conditioning appliance.
- 5.5.2. The test method shall be that described in paragraph 5.3. of this annex, except that the test temperature is $-18\text{ }^{\circ}\text{C} \pm 2\text{ }^{\circ}\text{C}$.
- 5.5.3. Interpretation of results as in paragraph 5.4. of this annex.
- 6. Test of resistance to the environment
 - 6.1. Test of resistance to abrasion
 - 6.1.1. Indices of difficulty and test method

The requirements of Annex 3, paragraph 4. shall apply; the test is performed for either 1,000, 500 or 100 cycles to measure abrasion of the surface of the product.
 - 6.1.2. Three flat square test pieces of 100 mm side for each type of surface shall be subjected to testing.
 - 6.1.3. Interpretation of results
 - 6.1.3.1. In the case of glazing of class L, the Taber abrasion test shall be considered to have given a satisfactory result if the increase of haze after abrasion does not exceed 2 per cent after 1,000 cycles on the outer surface of the test sample and 4 per cent after 100 cycles on the inner surface of the test sample.
 - 6.1.3.2. In the case of glazing of class M, the Taber abrasion test shall be considered to have given a satisfactory result if the increase of haze after abrasion does not exceed 10 per cent after 500 cycles on the outer surface of the test sample and 4 per cent after 100 cycles on the inner surface of the test sample.
 - 6.1.3.3. in the case of glazing of Class L for the abrasion on the outer surface of the test sample, either the Taber test or as an equivalent alternative the package of Sand drop test, Car-wash test and Wiper test shall apply as described in Annex 17, paragraphs 6.1.2., 6.1.3. and 6.1.4.
 - 6.1.3.4. For sun roofs no abrasion test is required.
 - 6.1.4. A set of samples for approval shall be considered satisfactory if all samples meet the requirements
 - 6.2. Test of resistance to simulated weathering
 - 6.2.1. Indices of difficulty and test method

The requirements of Annex 3, paragraph 6.4. shall apply. The total ultraviolet radiant exposure with the long arc xenon lamp shall be 500 MJ/m^2 . During irradiation the test pieces shall be exposed to water spray in continuous cycles. During a cycle of 120 minutes the test pieces

- are exposed to light without water spray for 102 minutes and to light with water spray for 18 minutes.
- 6.2.1.1.** Other methods giving equivalent results shall be allowed.
- 6.2.2.** Number of test pieces
- Three flat test pieces 130 mm x 40 mm cut from a flat sheet sample shall be subjected to testing.
- 6.2.3.** Interpretation of results
- 6.2.3.1.** The resistance to the simulated weathering shall be considered to have given a satisfactory result if:
- 6.2.3.1.1.** The light transmittance measured in accordance with Annex 3, paragraph 9.1. does not fall below 95 per cent of the pre-weathering value. Additionally, for windows which are required for driver visibility the value shall not fall below 70 per cent.
- 6.2.3.1.2.** No bubbles or other visible decompositions, discolouration, milkiness or crazing shall occur during weathering.
- 6.2.4.** A set of test pieces or samples submitted for approval shall be considered satisfactory from the point of view of the resistance to simulated weathering if all test pieces have given a satisfactory result.
- 6.3.** Cross-cut test
- 6.3.1.** Indices of difficulty and test method
- The requirements of Annex 3, paragraph 13. shall apply only to coated rigid products.
- 6.3.2.** The cross-cut test shall be carried out on one of the test pieces from paragraph 6.2.
- 6.3.3.** Interpretation of results
- 6.3.3.1.** The cross-cut test shall be considered to have given a satisfactory result if:
- 6.3.3.1.1.** At least the cross-cut value Gtl is met.
- 6.3.3.1.2.** The test piece shall be considered satisfactory from the point of view of approval if the test has given satisfactory results.
- 6.4.** Resistance-to-humidity test
- 6.4.1.** Indices of difficulty and test method
- The requirements of Annex 3, paragraph 7. shall apply.
- 6.4.2.** Ten flat square test pieces of 300 mm side, or ten original parts shall be subjected to testing.
- 6.4.3.** Interpretation of results
- 6.4.3.1.** The humidity test shall be considered to have given a satisfactory result if:
- 6.4.3.1.1.** No visible decompositions like bubbles or milkiness occur on any sample, and
- 6.4.3.1.2.** The light transmittance measured according to Annex 3, paragraph 9.1.

shall not fall to less than 95 per cent of the pre-test value and additionally to no less than 70 per cent, on any sample, for any window required for driver visibility.

- 6.4.4. After testing the test pieces shall be stored for at least 48 hours at a temperature of $23\text{ }^{\circ}\text{C} \pm 2\text{ }^{\circ}\text{C}$ and a relative humidity of 50 per cent ± 5 per cent, and then subjected to the 227 g ball drop test described under paragraph 5.3. of this annex.
- 6.5. Test of resistance to high temperature
 - 6.5.1. Indices of difficulty and test method

The requirements of Annex 3, paragraph 5. shall apply
 - 6.5.2. Three square test pieces of at least 300 mm x 300 mm which have been cut from three panes, one edge of which corresponds to the upper edge of the glazing shall be subjected to testing.
 - 6.5.3. Interpretation of results
 - 6.5.3.1. The test for resistance to high temperature shall be considered to give a positive result if bubbles or other defects are not formed more than 15 mm from an uncut edge or 25 mm from a cut edge of the test piece or sample or more than 10 mm away of any cracks which may occur during the test.
 - 6.5.3.2. A set of test pieces or samples submitted for approval shall be considered satisfactory from the point of view of the test for resistance to high temperature if all the tests give a satisfactory result;
- 6.6. Resistance-to-radiation test

This test has to be performed at the discretion of the laboratory conducting the tests.

 - 6.6.1. Indices of difficulty and test method

The requirements of Annex 3, paragraph 6. shall apply.
 - 6.6.2. Three test pieces of 76 mm x 300 mm shall be cut from the upper part of the pane in such a way that the upper edge of the test piece coincides with the upper edge of the pane. These test pieces shall be subjected to testing.
 - 6.6.3. Interpretation of results
 - 6.6.3.1. The test for resistance to radiation shall be deemed to have given a positive result if the following conditions are fulfilled:
 - 6.6.3.1.1. The total light transmittance when measured pursuant to paragraphs 9.1.1. and 9.1.2. of this annex does not fall below 95 per cent of the original value before irradiation and in any event does not fall:
 - 6.6.3.1.1.1. Below 70 per cent in the case of glass panes other than windscreens which are required to comply with the specifications regarding the driver's field of view in all directions;
 - 6.6.3.1.1.2. The test piece or sample may however show a slight coloration after irradiation when examined against a white background, but no other defect may be apparent.

- 6.6.3.2.** A set of test pieces or samples submitted for approval shall be considered satisfactory from the point of view of the resistance-to-radiation test if one of the following conditions is fulfilled:
- 6.6.3.2.1.** All the tests give a satisfactory result.
- 7.** **Optical qualities**
The requirements of Annex 3, paragraph 9.1. shall apply for products which are requisite for driver visibility.
- 7.1.** **Interpretation of results**
A set of 4 samples shall be considered as satisfactory if all samples give a satisfactory result.
- 8.** **Fire resistance test**
- 8.1.** **Indices of difficulty and test method**
The requirements of Annex 3, paragraph 10. shall apply.
- 8.2.** **Interpretation of results**
The fire-resistance test shall be considered to have given a satisfactory result if the burning rate is less than 110 mm/min.
- 8.2.1.** For the purpose of approval a set of samples will be considered satisfactory if all samples give a satisfactory result.
- 9.** **Resistance to chemicals**
- 9.1.** **Immersion test**
- 9.1.1.** **Indices of difficulty and test method**
The requirements of Annex 3, paragraph 11.2.1. shall apply.
- 9.1.2.** **Interpretation of results**
A set of four samples for each chemical shall be tested; for each chemical, in case of glazing of Class L, one of these samples shall be cross-cut according to paragraph 13. of Annex 3.
Three samples out of four, among which the cross-cut sample mentioned above when applicable, shall give satisfactory results for each chemical.
- 9.2.** **Test under load**
- 9.2.1.** **Indices of difficulty and test method**
The requirements of Annex 3, paragraph 11.2.4. shall apply.
- 9.2.2.** **Interpretation of results**
A set of four samples, not being the ones mentioned in paragraph 6.6.1. above, for each chemical shall be tested.
Three samples out of four shall give satisfactory results for each chemical.

Annex 19

Laminated rigid plastic windscreens

1. **Definition of type**

Laminated rigid plastic windscreens shall be deemed to belong to different types if they differ in at least one of the following principal or secondary characteristics.

 - 1.1. **The principal characteristics are as follows:**
 - 1.1.1. **Trade names or marks.**
 - 1.1.2. **The chemical designation of the single sheet material.**
 - 1.1.3. **The classification of the material by the manufacturer.**
 - 1.1.4. **The process of manufacture.**
 - 1.1.5. **The shape and dimensions.**

Laminated rigid plastic windscreens shall be deemed to belong to one group for the purposes of tests of mechanical properties and of resistance to the environment.
 - 1.1.6. **The nominal thickness 'e' of the pane, a manufacturing tolerance of $\pm n \cdot x$ mm being allowed ('n' being the number of layers of rigid plastic in the windscreen and x is the manufacturing tolerance of the single rigid plastic sheets in the windscreen, its value is depending on the process of manufacture and being given in Annex 14, paragraph 1.1.6.).**
 - 1.1.7. **The nominal thickness of the interlayer or interlayers,**
 - 1.1.8. **The nature and type of the interlayer or interlayers, e.g. PVB or other plastics-material interlayer or interlayers,**
 - 1.1.9. **Any special treatment which one of the layers of plastic may have undergone.**
 - 1.1.10. **The colouring of the plastic product.**
 - 1.1.11. **The nature of the surface coating.**
 - 1.2. **The secondary characteristics are as follows:**
 - 1.2.1. **The colouring (total or partial) of the interlayer or interlayers (colourless or tinted).**
 - 1.2.2. **The incorporation or otherwise of opaque obscuration.**
 - 1.2.3. **The presence or absence of conductors or heating elements.**
2. **General**
 - 2.1. **In the case of laminated rigid plastic windscreens tests other than headform tests and tests of optical qualities shall be conducted on flat test pieces which are either cut from actual windscreens or are specially made for the purpose. In either case the test pieces shall be in all respects rigorously representative of the serially produced windscreens for which approval is sought.**
 - 2.2. **The test pieces must be freed from protecting masking and have to be**

- cleaned carefully before the test.
- 2.2.1. They must be stored for 48 hours at a temperature of $23\text{ }^{\circ}\text{C} \pm 2\text{ }^{\circ}\text{C}$ and a relative humidity of 50 per cent ± 5 per cent.
3. Flexibility test
- 3.1. Indices of difficulty of the secondary characteristics
No secondary characteristic is involved.
- 3.2. Number of test pieces
One flat test piece measuring 300 mm x 25 mm shall be subjected to testing.
- 3.3. Test method
- 3.3.1. The method used shall be that described in Annex 3, paragraph 12.
- 3.4. Interpretation of results
For a test piece or sample to be considered rigid the vertical deflection of the test piece shall be less than or equal to 50 mm after 60 seconds.
4. Headform test on a complete windscreen
- 4.1. Indices of difficulty of the secondary characteristics
No secondary characteristic is involved.
- 4.2. Number of windscreens
Six complete windscreens from the smallest-developed-area series and six complete windscreens from the largest-developed-area series selected in accordance with the provisions of Annex 13, shall be tested.
- 4.3. Test method
- 4.3.1. The method used shall be that described in Annex 3, paragraph 3.2.
- 4.3.2. The drop height shall be 3 m. The HIC value is also to be measured.
- 4.4. Interpretation of results
The test shall be deemed to have given a satisfactory result if the following conditions are fulfilled:
- 4.4.1. The sample is not penetrated nor shall it break into fully separate large pieces.
- 4.4.2. The HIC value shall be less than 1,000.
- 4.4.3. A set of samples submitted for approval shall be considered satisfactory from the point of view of the headform test if all the tests give satisfactory results,
5. Mechanical strength test
- 5.1. 2,260 g ball test
- 5.1.1. Indices of difficulty of the secondary characteristics:
no secondary characteristics is involved
- 5.1.2. Number of test pieces
Twelve square test pieces of $300\text{ }^{+10/-0}$ mm shall be subjected to testing.

- 5.1.3. Test method**
- 5.1.3.1.** The method used shall be that prescribed in Annex 3, paragraph 2.2.
- 5.1.3.2.** The height of drop shall be 4 m at ambient temperature.
- 5.1.4. Interpretation of results**
- 5.1.4.1.** The test shall be considered to have given a satisfactory result if the ball does not pass through the glazing.
- 5.1.4.2.** A set of test pieces submitted for approval shall be considered satisfactory from the point of view of the 2,260 g ball test if eleven or more tests give a satisfactory result at the drop height.
- 5.2. 227 g ball test**
- 5.2.1. Indices of difficulty of the secondary characteristics:**
- (a) Without conductors, obscuration(s) or heating elements;
- (b) With conductors, obscuration(s) or heating elements.
- 5.2.2.** Number of test pieces twenty square test pieces of 300 +10/-0 mm or ten substantially flat finished parts shall be subjected to testing. In this later case the contact between the part and the supporting fixture shall be around the whole perimeter and of about 15 mm width. Upper and lower supporting frames shall be clamped together in a way that ensures that the movement of the test piece during the test shall not exceed 2 mm.
- 5.2.3. Test method**
- 5.2.3.1.** The method used shall be that prescribed in Annex 3, paragraph 2.1. Ten test pieces shall be tested at a temperature of +40 °C ± 2 °C and ten at a temperature of -18 °C ± 2 °C. To minimize the temperature change of the test piece, the test shall be performed within 30 seconds of the removal of the test piece from the conditioning appliance.
- 5.2.3.2.** The height of drop shall be 9 m at +40 °C temperature and 8.5 m at -18 °C.
- 5.2.4. Interpretation of results**
- 5.2.4.1.** The ball test shall be considered to have given a satisfactory result if the following conditions are met:
- (a) The ball does not penetrate the test piece;
- (b) The test piece does not break into separate pieces.
- As a result of the impact, cracks and fissures in the test piece shall however be permitted.
- 5.2.4.2.** A set of test pieces submitted for approval shall be considered satisfactory from the point of view of the 227 g ball test if eight or more separate tests for each temperature give a satisfactory result at the drop height.
- 6. Test of resistance to the environment**
- 6.1. Test of resistance to abrasion**
- For the purpose of testing the resistance to abrasion, either the Taber test or as an equivalent alternative the package of Sand drop test, Car-

wash test and Wiper test shall be performed.

6.1.1. Taber test

6.1.1.1. Indices of difficulty and test method

The requirements of Annex 3, paragraph 4. shall apply; the test is performed for 1,000 cycles to measure abrasion of the surface of the product.

6.1.1.2. Three flat square test pieces of 100 mm for each type of surface shall be subjected to testing.

6.1.1.3. Interpretation of results

The safety glazing shall be considered satisfactory with respect to abrasion resistance if the increase of haze as a result of abrasion of the test piece does not exceed 2 per cent.

6.1.1.4. A set of samples for approval shall be considered satisfactory if all samples meet the requirements.

6.1.2. Sand Drop Test

6.1.2.1. Indices of difficulty and test method

The requirements of Annex 3, paragraph 4.7. shall apply. Three kilograms of sand shall be used.

6.1.2.2. Interpretation of results

The safety glazing shall be considered satisfactory if the increase of haze of the test piece does not exceed 5 per cent.

6.1.2.3. A set of samples for approval shall be considered satisfactory if all samples meet the requirements.

6.1.3. Car Wash Test

6.1.3.1 Indices of difficulty and test method

A car wash equipment as described in paragraph 4.8.1. of Annex 3 to this Regulation shall be used. Ten washing operations (10 double passes) shall be carried out.

6.1.3.2. Three flat pieces 50 mm x 100 mm of each type shall be taken from the flattest part of the windscreen in the area specified in paragraph 2.2. of Annex 21 (test area A). The test shall be carried out on the face corresponding to the outside of the windscreen.

6.1.3.3. Interpretation of results

The safety glazing shall be considered satisfactory if the increase of haze of the test piece does not exceed 2 per cent.

6.1.3.4. A set of samples for approval shall be considered satisfactory if all samples meet the requirements.

6.1.4. Wiper test

6.1.4.1. Indices of difficulty and test method

A wiper laboratory equipment as described in paragraph 4.9.1. of Annex 3 to this Regulation shall be used. [20.000] wiper cycles shall be carried out.

- 6.1.4.2. Three absolutely flat test samples of 150 mm x 100 mm shall be tested. The test shall be carried out on the face corresponding to the outside of the windscreen.
- 6.1.4.3. Interpretation of results
 - The safety glazing shall be considered satisfactory if the increase of haze as a result of abrasion of the test piece does not exceed 2 per cent.
- 6.1.4.4. A set of samples for approval shall be considered satisfactory if all samples meet the requirements.
- 6.2. Test of resistance to simulated weathering
 - 6.2.1. Indices of difficulty and test method
 - The requirements of Annex 3, paragraph 6.4. shall apply. The total ultraviolet radiant exposure with the long arc xenon lamp shall be 500 MJ/m². During irradiation the test pieces shall be exposed to water spray in continuous cycles. During a cycle of 120 minutes the test pieces are exposed to light without water spray for 102 minutes, and to light with water spray for 18 minutes.
 - 6.2.1.1. Other methods giving equivalent results shall be allowed.
 - 6.2.2. Number of test pieces
 - Three flat test pieces 130 mm x 40 mm cut from a flat sheet sample shall be subjected to testing.
 - 6.2.3. Interpretation of results
 - 6.2.3.1. The resistance to the simulated weathering shall be considered to have given a satisfactory result if:
 - 6.2.3.1.1. The light transmittance measured in accordance with Annex 3, paragraph 9.1. does not fall below 95 per cent of the pre-weathering value. Additionally, the value shall not fall below 70 per cent.
 - 6.2.3.1.2. No bubbles or other visible decompositions, discolourations, milkiness or crazing shall occur during weathering.
 - 6.2.4. A set of test pieces or samples submitted for approval shall be considered satisfactory from the point of view of the resistance to simulated weathering if all test pieces have given a satisfactory result.
- 6.3. Cross-cut test
 - 6.3.1. Indices of difficulty and test method
 - The requirements of Annex 3, paragraph 13. shall apply only to coated rigid products.
 - 6.3.2. The cross-cut test shall be carried out on one of the test pieces from paragraph 6.2.
 - 6.3.3. Interpretation of results
 - 6.3.3.1. The cross-cut test shall be considered to have given a satisfactory result if at least the cross-cut value Gt1 is met.
- 6.4. Resistance-to-humidity test
 - 6.4.1. Indices of difficulty and test method

- The requirements of Annex 3, paragraph 7. shall apply.
- 6.4.2. Ten flat square test pieces of 300 mm side or ten test pieces of same size cut from windscreens, or ten original parts shall be subjected to testing.
- 6.4.3. Interpretation of results
- 6.4.3.1. The humidity test shall be considered to have given a satisfactory result if:
- 6.4.3.1.1. No visible decompositions like bubbles or milkiness occur on any sample, and
- 6.4.3.1.2. The light transmittance measured according to Annex 3, paragraph 9.1. shall not fall to less than 95 per cent of the pre-test value and additionally to no less than 70 per cent, on any sample.
- 6.4.4. After testing the test pieces shall be stored for at least 48 hours at a temperature of $23\text{ }^{\circ}\text{C} \pm 2\text{ }^{\circ}\text{C}$ and a relative humidity of 50 per cent ± 5 per cent, and then subjected to the 227 g ball drop test, under ambient temperature and height of drop of 8.5 m, described under paragraph 5.2. of this annex.
- 6.5. Fire resistance test
- 6.5.1. Indices of difficulty and test method
- The requirements of Annex 3, paragraph 10. shall apply.
- 6.5.2. Interpretation of results
- The fire-resistance test shall be considered to have given a satisfactory result if the burning rate is less than 110 mm/min.
- 6.5.2.1. For the purpose of approval a set of samples will be considered satisfactory if all samples give a satisfactory result.
- 6.6. Resistance to chemicals
- 6.6.1. Immersion test
- 6.6.1.1. Indices of difficulty and test method
- The requirements of Annex 3, paragraph 11.2.1. shall apply.
- 6.6.1.2. Interpretation of results
- A set of four samples for each chemical shall be tested; for each chemical, one of these samples shall be cross-cut according to paragraph 13. of Annex 3.
- Three samples out of four, among which the cross-cut sample mentioned above, shall give satisfactory results for each chemical.
- 6.6.2. Test under load
- 6.6.2.1. Indices of difficulty and test method
- The requirements of Annex 3, paragraph 11.2.4. shall apply.
- 6.6.2.2. Interpretation of results
- A set of four samples, not being the ones mentioned in paragraph 6.6.1. above, for each chemical shall be tested.

- Three samples out of four shall give satisfactory results for each chemical.
- 6.7. Test of resistance to high temperature
- 6.7.1. Indices of difficulty and test method
The requirements of Annex 3, paragraph 5. shall apply.
- 6.7.2. Three square test pieces of at least 300 mm x 300 mm which have been cut from three panes, one edge of which corresponds to the upper edge of the glazing shall be subjected to testing.
- 6.7.3. Interpretation of results
- 6.7.3.1. The test for resistance to high temperature shall be considered to give a positive result if bubbles or other defects are not formed more than 15 mm from an uncut edge or 25 mm from a cut edge of the test piece or sample or more than 10 mm away of any cracks which may occur during the test.
- 6.7.3.2. A set of test pieces or samples submitted for approval shall be considered satisfactory from the point of view of the test for resistance to high temperature if all the tests give a satisfactory result;
- 6.8. Resistance-to-radiation test
This test has to be performed at the discretion of the laboratory conducting the tests.
- 6.8.1. Indices of difficulty and test method
The requirements of Annex 3, paragraph 6. shall apply.
- 6.8.2. Three test pieces of 76 mm x 300 mm shall be cut from the upper part of the pane in such a way that the upper edge of the test piece coincides with the upper edge of the pane. These test pieces shall be subjected to testing.
- 6.8.3. Interpretation of results
- 6.8.3.1. The test for resistance to radiation shall be deemed to have given a positive result if the following conditions are fulfilled:
- 6.8.3.1.1. The total light transmittance when measured pursuant to paragraphs 9.1.1. and 9.1.2. of this annex does not fall below 95 per cent of the original value before irradiation and in any event does not fall below 70 per cent.
- 6.8.3.1.2. The test piece or sample may however show a slight coloration after irradiation when examined against a white background, but no other defect may be apparent.
- 6.8.3.2. A set of test pieces or samples submitted for approval shall be considered satisfactory from the point of view of the resistance-to-radiation test if one of the following conditions is fulfilled:
- 6.8.3.2.1. All the tests give a satisfactory result;
- 6.9. Test of resistance of temperature changes
- 6.9.1. Indices of difficulty and test method
The requirements of Annex 3, paragraph 8. shall apply.

6.9.2. Interpretation of results

The test for resistance of temperature changes shall be considered to have given a satisfactory result if the test pieces do not show any evidence of cracking, clouding, separation of layers or other apparent deterioration.

7. Optical qualities

The requirements concerning optical qualities set out in Annex 3, paragraph 9. shall apply to every type of windscreen.

7.1. Interpretation of results

A set of 4 samples shall be considered as satisfactory if all samples give satisfactory results."

Annexes 17 to 19 (former), renumber as Annexes 20 to 22.

Annex 20 renumber as Annex 23 and insert new paragraphs 2.11. to 2.13., to read:

"2.11. Rigid plastic windscreens

2.11.1. Headform test, without HIC measurement, in accordance with the requirements of Annex 17, paragraph 4.

2.11.2. 227 g ball test in accordance with the requirements of Annex 17, paragraph 5.

2.11.3. Test of resistance to abrasion in accordance with the requirements of Annex 17, paragraph 6.1.

2.11.4. Test of resistance to chemicals in accordance with the requirements of Annex 17, paragraph 6.6. and Annex 3, paragraph 11.

2.11.5. Light transmission measurement in accordance with the requirements of Annex 3, paragraph 9.1.

2.11.6. Optical distortion test in accordance with the requirements of Annex 3, paragraph 9.2.

2.11.7. Secondary image separation test in accordance with the requirements of Annex 3, paragraph 9.3.

2.12. Laminated rigid plastic panes

2.12.1. 227 g ball test in accordance with the requirements of Annex 18, paragraph 5.

2.12.2. Test of resistance to high temperature in accordance with the requirements of Annex 18, paragraph 6.5.

2.12.3. Test of resistance to abrasion in accordance with the requirements of Annex 18, paragraph 6.1.

2.12.4. Test of resistance to chemicals in accordance with the requirements of Annex 18, paragraph 9.

2.12.5. Test of light transmission measurement in accordance with the requirements of Annex 3, paragraph 9.1.

2.13. Laminated rigid plastic windscreens

2.13.1. Headform test, without HIC measurement, in accordance with the requirements of Annex 19, paragraph 4.

- 2.13.2. 2,260 g ball test in accordance with the requirements of Annex 19, paragraph 5.1.
- 2.13.3. Test of resistance to abrasion in accordance with the requirements of Annex 19, paragraph 6.1.
- 2.13.4. Test of resistance to chemicals in accordance with the requirements of Annex 19, paragraph 6.6. and Annex 3, paragraph 11.
- 2.13.5. Light transmission measurement in accordance with the requirements of Annex 3, paragraph 9.1.
- 2.13.6. Optical distortion test in accordance with the requirements of Annex 3, paragraph 9.2.
- 2.13.7. Secondary image separation test in accordance with the requirements of Annex 3, paragraph 9.3.
- 2.13.8. Test of resistance to high temperature in accordance with the requirements of Annex 3, paragraph 5."

Annex 23 (former Annex 20), paragraph 3.6.2., replace the reference to "Annex 18" by "Annex 21".

Annex 21, renumber as Annex 24 and amend to read:

- "4.1.2. The windscreen shall be type approved for the vehicle type for which it is intended to be fitted. **When applicable, the windscreen shall in addition be type approved in accordance with the specific device mentioned in Annex 3, paragraph 4.9.2.**
- 4.1.3. The windscreen shall be correctly fitted with reference to the vehicle driver's "R" point. **When applicable, the windscreen shall in addition be fitted on the vehicle in accordance with the specific device mentioned in Annex 3, paragraph 4.9.2."**

II. Justification

New types of plastic glazing are in consideration by the automotive industry for installation in vehicles because of their weight reduction properties which leads to less consumption of fuel and less CO₂ emissions. These new glazing types are covered by the proposed amendments.
