



Economic and Social Council

Distr.: General
7 April 2011
English
Original: English and French

Economic Commission for Europe

Inland Transport Committee

World Forum for Harmonization of Vehicle Regulations

154th session

Geneva, 21–24 June 2011

Item 4.14.1 of the provisional agenda

1958 Agreement – Consideration of draft corrigenda to existing Regulations submitted by GRE

Proposal for Corrigendum 1 to the 04 series of amendments to Regulation No. 10 (Electromagnetic compatibility)

Submitted by the Working Party on Lighting and Light-signalling*

The text reproduced below was prepared by the Working Party on Lighting and Light-Signalling (GRE) to update some of the figures in document ECE/TRANS/WP.29/2011/8. It is based on informal document WP.29-153-15, distributed during the 153rd session of WP.29 (ECE/TRANS/WP.29/1089, para. 56). It is submitted to the World Forum for Harmonization of Vehicle Regulations (WP.29) and to the Administrative Committee (AC.1) for consideration.

* In accordance with the programme of work of the Inland Transport Committee for 2010-2014 (ECE/TRANS/208, para. 106, ECE/TRANS/2010/8, programme activity 02.4), the World Forum will develop, harmonize and update Regulations in order to enhance the performance of vehicles. The present document is submitted in conformity with that mandate.

Annex 4 - Appendix

Figure 3, correct to read:

"Figure 3

Vehicle in configuration "RESS charging mode coupled to the power grid"

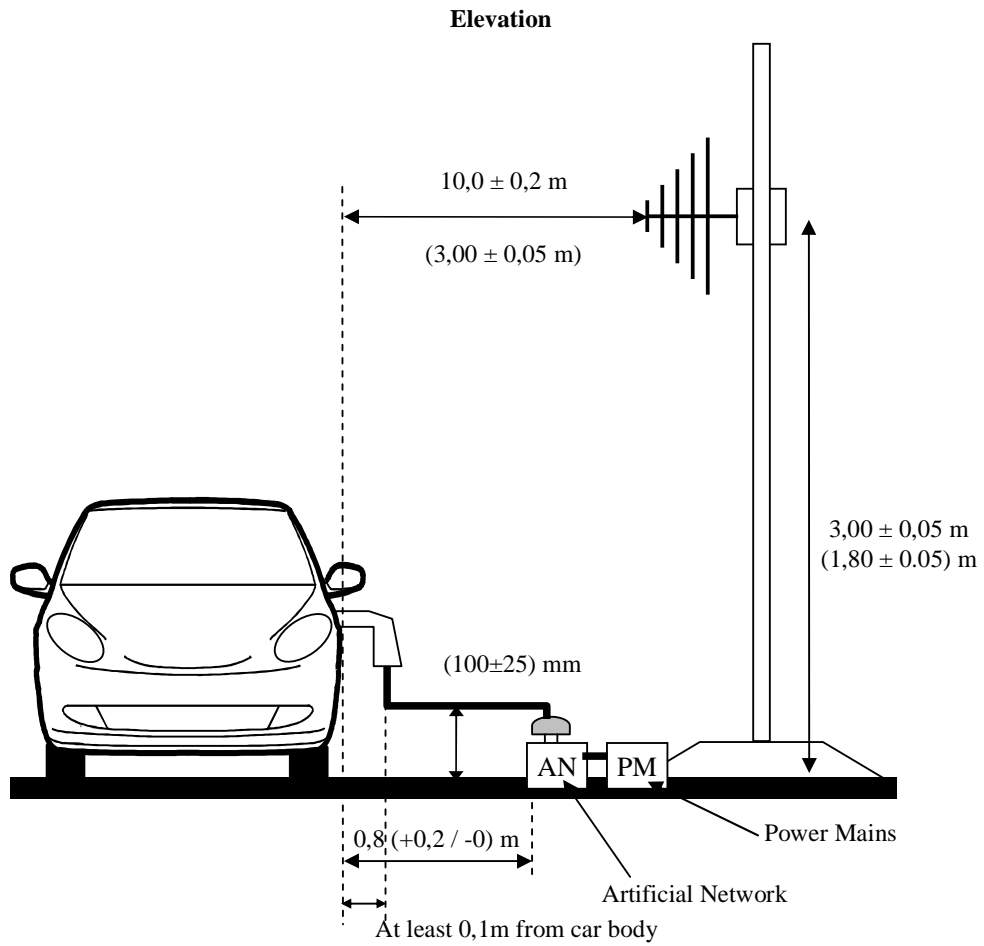

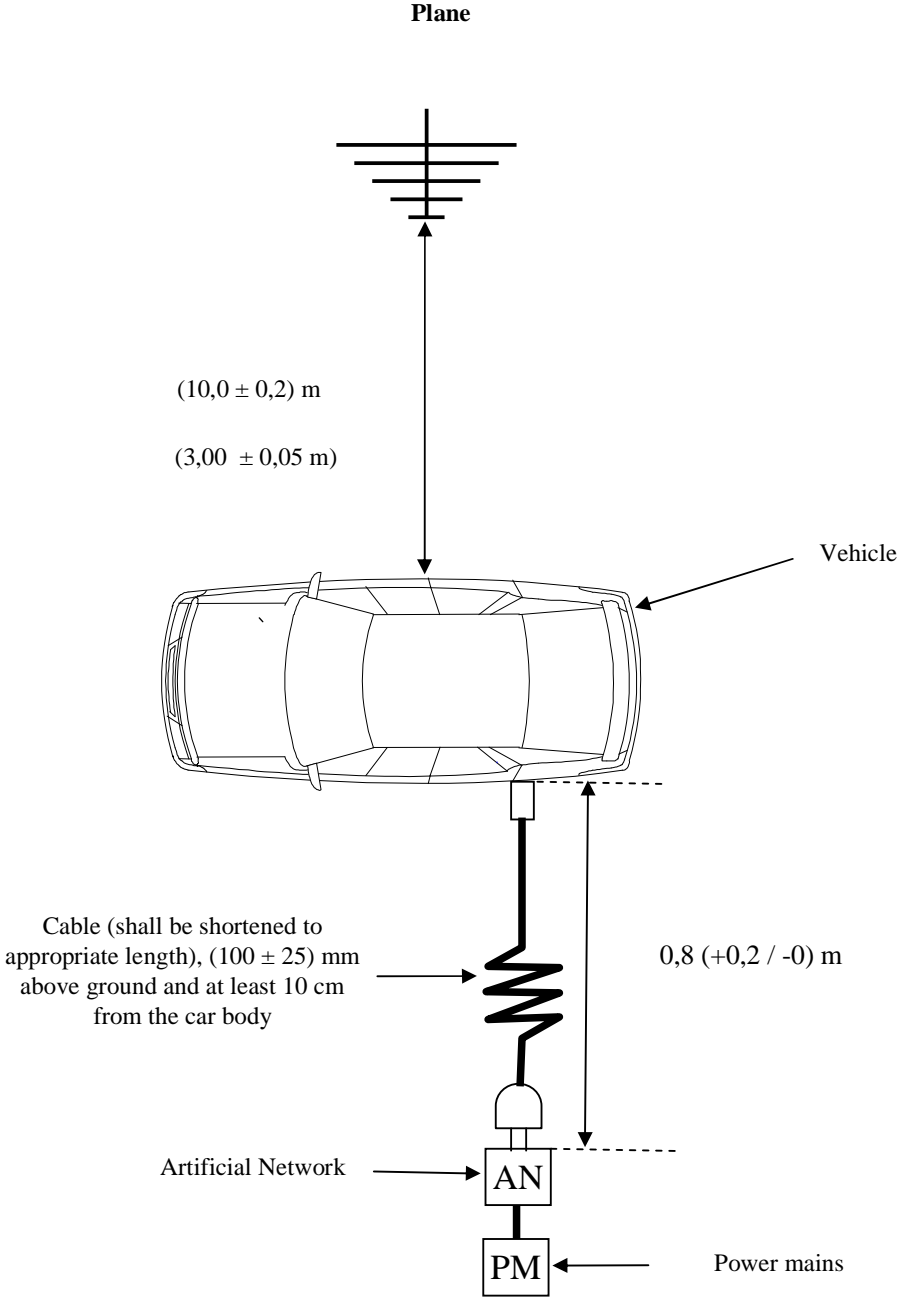

Annex 6 - Appendix

Figure 4, correct to read:

"Figure 4

Vehicle in configuration "RESS in charging mode coupled to the power grid"

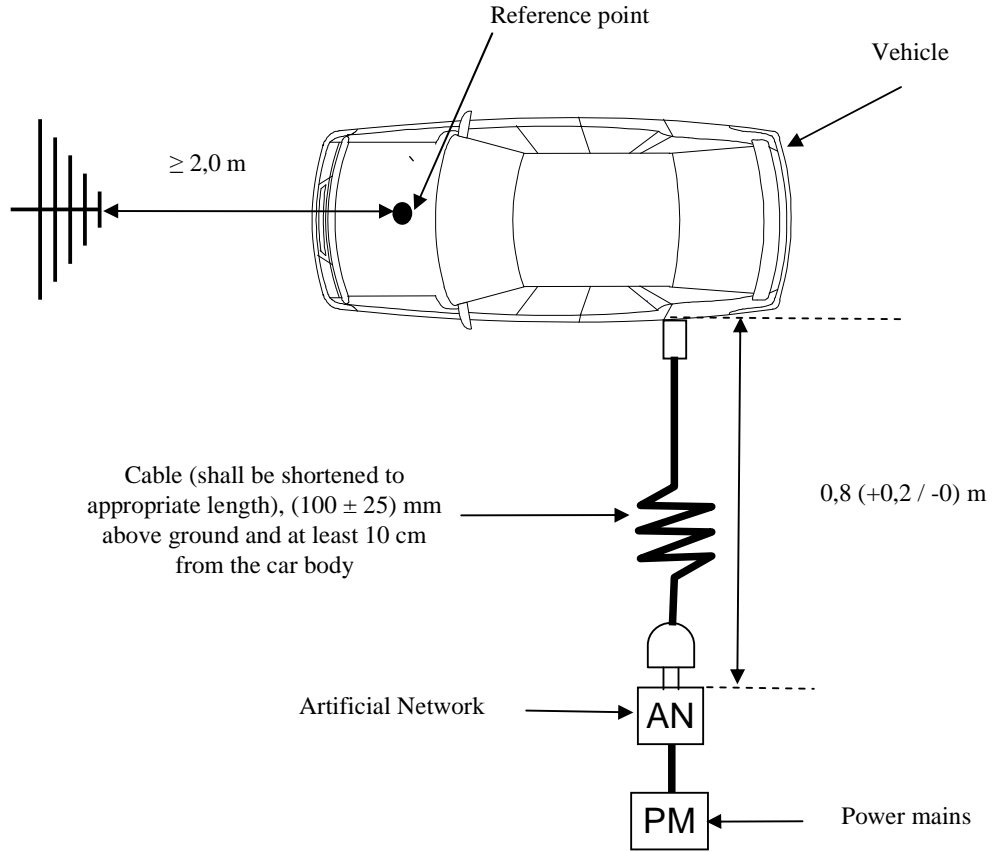

"

Annex 13 – Appendix 1

Figure 1, correct to read:

"Figure 1
Vehicle in configuration "RESS charging mode coupled to the power grid"

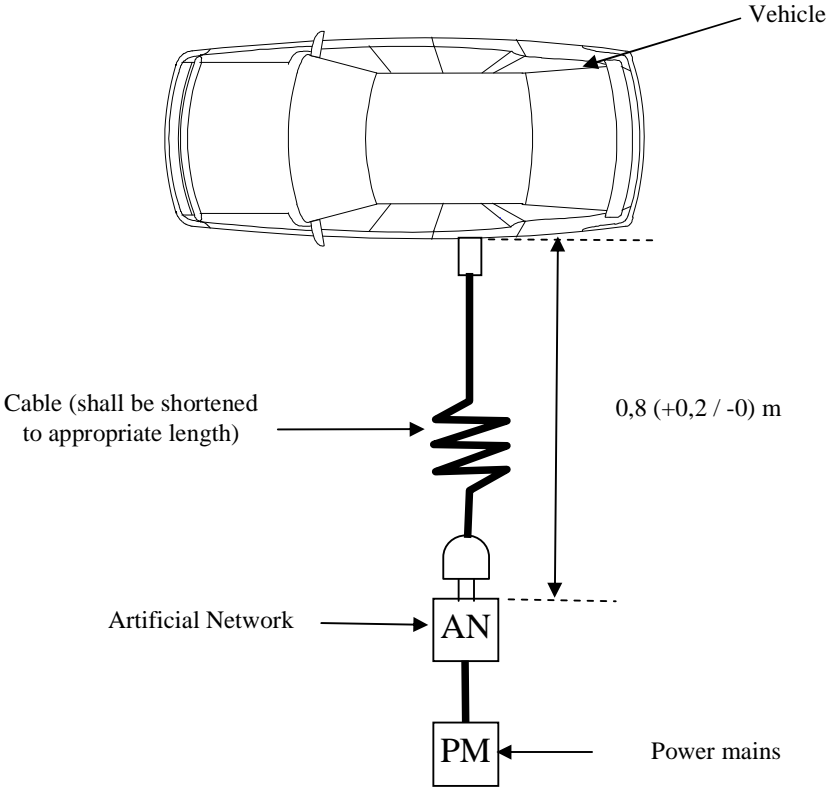

"

Annex 14 – Appendix 1

Figure 1, correct to read:

"Figure 1

Vehicle in configuration "RESS charging mode coupled to the power grid"

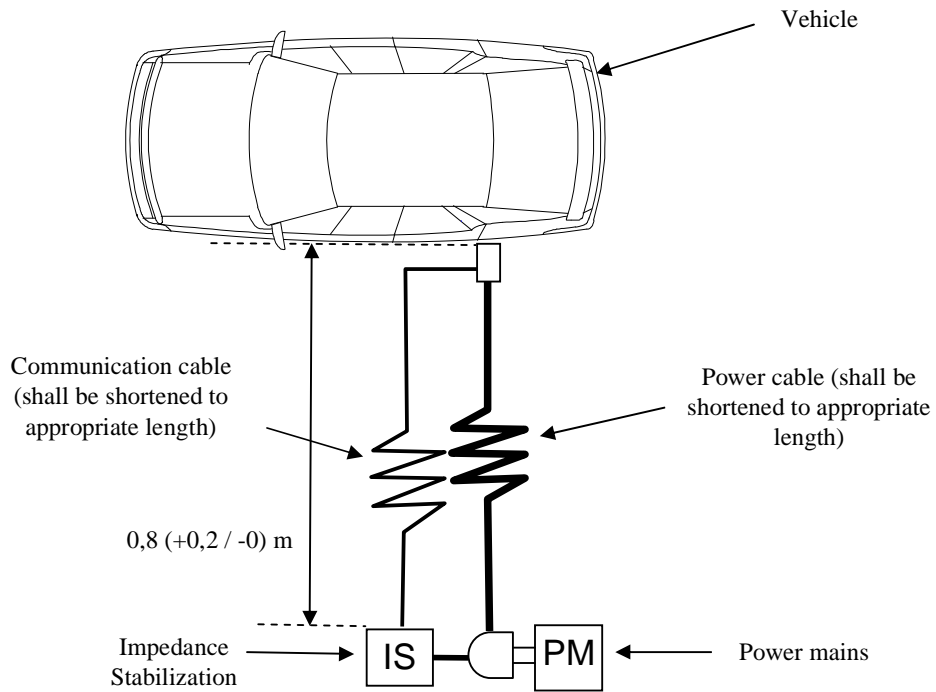

"