

R.xxx

DRAFT

~~Distr.~~
~~GENERAL~~
~~TRANS/WP.29/GRE/2002/18/Rev.1~~
30.July 2003
ENGLISH ONLY

ECONOMIC COMMISSION FOR EUROPE
INLAND TRANSPORT COMMITTEE

World Forum for Harmonization of Vehicle Regulations (WP.29)

Working Party on Lighting and Light-Signalling (GRE)
(Fifty first session, agenda item 2.1. and 2.2.)

PROPOSAL FOR A NEW DRAFT REGULATION:

UNIFORM PROVISIONS CONCERNING THE APPROVAL OF
ADAPTIVE FRONTLIGHTING SYSTEMS (AFS)
FOR MOTOR VEHICLES

Transmitted by the Expert from the Working Party "Brussels 1952" (GTB)

Note: At its forty-eighth session GRE discussed a proposal by GTB for a new draft Regulation on Adaptive Frontlighting Systems (AFS) for motor vehicles (TRANS/WP.29/GRE/2002/18) together with explanatory notes (TRANS/WP.29/GRE/ 2002/19) and draft amendments to Regulation No.48 concerning AFS (TRANS/WP.29/GRE/2002/20).

According to the decision of GRE (TRANS/WP.29/GRE/48) informal meetings were held on this matter: 1stGRE-AFS 2-4 July 2002, 2ndGRE-AFS 28-30 January 2003, 3rdGRE-AFS 7/8/11 March 2003 **and 4thGRE-AFS 15-17 July 2003.**

The text reproduced below represents the outcome and state of the discussion as laid down in the respective reports.

Editorial note: Text in brackets is under consideration.; **deleted text parts have been removed or** (in certain cases) are indicated by stroke-through characters; **re-numbering was performed where necessary/useful.**

Note: This document is distributed to the Experts on Lighting and Light-Signalling only.

GE.02-

<u>CONTENTS</u>		page
A.	ADMINISTRATIVE PROVISIONS.....	3
	SCOPE	3
1.	DEFINITIONS.....	3
2.	APPLICATION FOR APPROVAL OF A <i>System</i>	5
3.	MARKINGS	9
4.	APPROVAL	10
B.	TECHNICAL REQUIREMENTS FOR SYSTEMS	
5.	GENERAL SPECIFICATIONS	14
6.	ILLUMINATION	17
	6.1. General provisions.....	17
	6.2. Provisions concerning passing beam.....	17
	6.3. Provisions concerning <i>driving beam</i>	19
	6.4. Other Provisions	21
7.	COLOUR	22
C.	FURTHER ADMINISTRATIVE PROVISIONS	
8.	MODIFICATION OF THE <i>SYSTEM</i> TYPE AND EXTENSION OF APPROVAL.....	22
9.	CONFORMITY OF PRODUCTION	22
10.	PENALTIES FOR NON-CONFORMITY OF PRODUCTION	23
11.	PRODUCTION DEFINITELY DISCONTINUED.....	23
12.	NAMES AND ADDRESSES OF TECHNICAL SERVICES ..	23
ANNEXES		
1	COMMUNICATION.....	24
2	EXAMPLES OF ARRANGEMENT OF APPROVAL MARKS	28
3	<i>PASSING BEAM PHOTOMETRIC REQUIREMENTS</i>	37
4	TESTS FOR STABILITY OF PHOTOMETRIC PERFORMANCE OF <i>SYSTEMS</i> IN OPERATION.....	41
5	MINIMUM REQUIREMENTS FOR C.O.P. CONTROL PROCEDURES	47
6	REQUIREMENTS FOR <i>SYSTEMS</i> INCORPORATING LENSES OF PLASTIC MATERIAL – TESTING OF LENS OR MATERIAL SAMPLES AND COMPLETE <i>SYSTEMS OR PART(S) OF SYSTEMS</i>	50
7	MINIMUM REQUIREMENTS FOR SAMPLING BY AN INSPECTOR	60
8	<i>REQUIREMENTS FOR SYSTEMS INCORPORATING LIGHT SOURCES NOT BEING APPROVED ACCORDING TO REGULATION NO. 37 OR 99</i>	65
9	<i>PASSING BEAM "CUT-OFF" AND AIMING PROVISIONS</i>	69
10	<i>PHOTOMETRIC MEASUREMENT PROVISIONS</i>	72
11	DESCRIPTION FORMS	75

A. ADMINISTRATIVE PROVISIONS

SCOPE

This Regulation applies to *adaptive frontlighting systems (AFS) for motor vehicles*.

1. DEFINITIONS

For the purpose of this Regulation:

- 1.1. *the definitions given in Regulation No. 48 and its series of amendments in force at the time of application for type approval shall apply;*
- 1.2. ***"Adaptive front lighting system" (or "system") means a lighting device, providing two or more differing classes for automatic adaptation of the beam characteristics to varying conditions of use of the dipped-beam (passing beam) and, if it applies, the main-beam (driving-beam); such systems consist of the 'system control', one or more 'supply and operating device(s)', if any, and the 'installation units' of the right and of the left side of the vehicle;***
- 1.3. ***"Class" of a passing beam (C, V, E or W) means the designation of a passing beam, identified by particular provisions according to this Regulation and Regulation No.48 1/;"***
- 1.4. ***"Mode" of a passing beam (C1, C2,) means a beam of a front-lighting function provided by a system within the relevant provisions for one of the classes, designed and specified by the manufacturer for adaptation to dedicated vehicle and ambient conditions.***
- 1.4.1. ***"Bending mode" means a mode of a front-lighting function with its illumination being laterally moved or modified (to obtain an equivalent effect), designed for bends, curves or intersections of the road, and, identified by particular photometric provisions;***
- 1.4.2. ***"Category 1 bending mode" means a bending mode with horizontal movement of the kink of the cut-off;***
- 1.4.3. ***"Category 2 bending mode" means a bending mode without horizontal movement of the kink of the cut-off;***

1/ For explanation only.

The provisions of the classes are dedicated to conditions as follows: class C for the basic beam, class V for use in lit areas such as towns, class E for use on roads such as motorways, class W for use in adverse conditions such as wet road.

- 1.5. "Lighting unit" means a light emitting part of the system, which may consist of optical, mechanical and electrical components, designed to provide or contribute to the beam of one or more front-lighting function(s) provided by the system;
- 1.6. "Installation unit" means an indivisible housing (lamp body) with one or more lighting unit(s) being contained;
- 1.7. "Right side" respectively "left side" means the combined total of the lighting units intended to be installed to that side of the longitudinal median plane of the vehicle, relative to its forward motion;
- 1.8. "System control" means that part(s) of the system receiving the signals from the vehicle and controlling the operation of the lighting units automatically;
- 1.9. "Neutral state" means the state of the AFS when a defined mode of the class C ~~(basic)~~ passing beam or of the main beam, if any, is produced, specified for initial adjustment of the AFS or parts of;
- 1.10. "Signal" means any AFS control signal as defined in Regulation No. 48 or, any additional control input to the system or, a control output from the system to the vehicle;
- 1.11. "Signal generator" means a device, re-producing one or more of the signals for system tests;
- 1.12. "Supply and operating device" means one or more components of a system providing power to one or more parts of the system, including such as power and/or voltage control(s) for one or more light sources as e.g. electronic light source control gears;
- 1.13. "System reference axis" means the intersection line of the vehicle's longitudinal median plane with the horizontal plane through the centre of reference of one lighting unit specified in the drawings according to paragraph 2.2.1. below;
- 1.14. "Lens" means the outermost component of an installation unit, which transmits light through the illuminating surface;
- 1.15. "Coating" means any product(s) applied in one or more layers to the outer face of a lens;
- 1.16. Systems of different "types" means systems which differ in such essential respects as:
- 1.16.1. the trade name or mark(s);
- 1.16.2. the inclusion or elimination of components capable of altering optical characteristics/ photometric properties of the system;

- 1.16.3.** suitability for right-hand or left-hand traffic or for both traffic systems;
- 1.16.4.** the *front-lighting function(s), mode(s) and classes* produced;
- 1.16.5.** the materials constituting the lenses and coatings, if any;
- 1.16.6.** *the category of replaceable light source(s) or, if applicable, the light source module(s) used;*
- 1.16.7.** *the characteristic(s) of the signal(s), specified for the system;*
- 1.17.** *"Aiming" means the positioning of the beam or part thereof on an aiming screen according to the relevant criteria;*
- 1.18.** *"Adjustment" means the use of the means provided by the system for vertical and/or horizontal aiming of the beam;*
- 1.19.** *"Traffic-change **function**" means any front-lighting function or a mode thereof, or part(s) thereof only, or any combination of these, intended to avoid glare and provide sufficient illumination in case where a vehicle being equipped with a system designed for one traffic direction only is temporarily used in a country with the opposite direction of traffic.*
- 1.20.** *"Substitute function" means any specified front-lighting and/or front light-signalling, be it a front-lighting and/or a front light-signalling function, or a mode thereof, or part(s) thereof only, or any combination of it, intended to replace a front-lighting function/ mode in case of failure.*
- 2.** APPLICATION FOR APPROVAL OF A SYSTEM
- 2.1.** The application for approval shall be submitted by the owner of the trade name or mark or by his duly accredited representative.
- It shall specify:
- 2.1.1.** *the front-lighting functions, which are intended to be provided by the system, for which Approval is sought according to this Regulation;*
- 2.1.1.1.** *any other front-lighting or front light signalling function(s), provided by any lamp(s) being grouped, combined or reciprocally incorporated to the lighting units of the system, for which Approval is sought; sufficient information for identification of the respective lamp(s) and indication of the Regulation(s), according to which they are intended to be (separately) approved;*

- 2.1.2. whether the passing beam is designed for both left-hand and right-hand traffic or for either left-hand or right-hand traffic only;
- 2.1.3. if the *system* is equipped with *one or more adjustable lighting unit(s)*:
 - 2.1.3.1. the mounting position(s) of the *respective lighting unit(s)* in relation to the ground and the longitudinal median plane of the vehicle;
 - 2.1.3.2. the maximum angles above and below the normal position(s) which the device(s) *for vertical* adjustment can achieve;
- 2.1.4. *the category, as listed in Regulation No. 37 or 99, of replaceable light source(s) used;*
- 2.1.5. *if the system is equipped with one or more light source modules:*
 - 2.1.5.1. *specific information sufficient to permit identification of the non-replaceable light source(s) used, including the part number assigned by the light source manufacturer and its objective luminous flux;*
 - 2.1.5.2. *specific information sufficient to permit identification of the light source module(s);*
 - 2.1.5.3. *identification of the installation unit(s) of which said light source module(s) is/are a part;*
- 2.1.6. *if the system is equipped with one or more non-replaceable light source(s) not being part of a light source module:*
 - 2.1.6.1. *specific information sufficient to permit identification of the non-replaceable light source(s) used, including the part number assigned by the light source manufacturer and its objective luminous flux;*
 - 2.1.6.3. *identification of the lighting unit(s) of which said light source(s) is/are a non-replaceable part;*
- 2.1.7. *the operation conditions e.g. different input voltages according to the provisions of the annex 10 to this Regulation, if applicable.*
- 2.2. *Every application for approval shall be accompanied by:*
 - 2.2.1. *drawings in triplicate in sufficient detail to permit identification of the type, showing the position(s) intended for the approval number(s) and the additional symbols in relation to the circle(s) of the approval mark(s), and showing in what geometrical position the lighting units are to be mounted on the vehicle in relation to ground and vehicle longitudinal median plane, and showing each of them in vertical (axial)*

section and in front elevation, with main details of the optical design including the axis/axes of reference and the point(s) to be taken as centre(s) of reference in the tests and any optical features, of the lens, if applicable;

- 2.2.1.1. if the system is equipped with one or more light source modules: the drawing(s) shall contain sufficient details to identify the light source module(s) and the light source(s) being part thereof, including the position(s) intended for the information and markings according paragraphs 2.1.5. and 3.6. of this Regulation;*
- 2.2.2. a concise technical description of the system specifying:*
- (a) the lighting function(s) and their modes to be provided by the system 2/;*
 - (b) the lighting units contributing to each of them 2/, and the signals 3/ with the technical characteristics relevant to their operation;*
 - (c) which categories 2/ of the bending mode requirements apply, if any;*
 - (d) which set(s) of class W passing beam provisions according to annex 3 of this Regulation apply, if any;*
 - (e) which lighting units 3/ provide or contribute to one or more passing beam cut-off(s);*
 - (f) the indication(s) 2/ according to the provisions of paragraph 6.4.6. of this Regulation with respect to the paragraphs 6.20.6.1.2. and 6.20.6.1.3. of Regulation No. 48;*
 - (g) which lighting units are designed to provide the minimum passing beam illumination according to the paragraph 6.2.9.1. of this Regulation;*
 - (h) mounting and operation specifications for test purposes;*
 - (i) any other relevant information;*
- 2.2.2.1. the safety concept as laid down in the documentation describing, to the satisfaction of the Technical Service responsible for type approval tests:*
- (i) the measures designed into the system to ensure compliance with the provisions of paragraphs 5.7.3., 5.9.1., 6.2.6.4. below, and indicating the instructions for their verification according to 6.2.7. below, and,*

2/ to be indicated in a form conforming to the model of annex 1

3/ to be indicated in a form conforming to the model of annex 11

- (ii) *the relevant failure cases according to paragraph 5.9.1.;*
- 2.2.2.2. *the make and type of supply and operating device(s), if any and if not being part of an installation unit;*
- 2.2.2.3. *if the system is equipped with one or more light source modules and/or lighting units which incorporates one or more light sources not being approved according to Regulation No. 37 or 99: a quantitative specification indicating compliance with the requirements of annex 8 to this Regulation;*
- 2.2.2.4. *the technical characteristics which enable the system to be adapted for different directions of traffic.*
- 2.2.3. *two samples of the type of system, for which approval is sought, including the mounting devices, supply and operating devices, and signal generators if any;*
- 2.2.4. *for the test of plastic material of which the lenses are made:*
 - 2.2.4.1. *fourteen lenses;*
 - 2.2.4.1.1. *ten of these lenses may be replaced by ten samples of material at least 60 x 80mm in size, having a flat or convex outer surface and a substantially flat area (radius of curvature not less than 300 mm) in the middle measuring at least 15 x 15 mm;*
 - 2.2.4.1.2. *every such lens or sample of material shall be produced by the method to be used in mass production;*
 - 2.2.4.2. *a lighting element or optical assembly, if applicable, to which the lenses can be fitted in accordance with the manufacturer's instructions;*
- 2.2.5. *for testing the resistance of the light transmitting components made of plastic material against UV radiation of those light source(s) inside the system, which can emit UV radiation as e.g. gas discharge light sources, according to paragraph 2.2.4. of annex 6 to this Regulation:*

one sample of each relevant material being used in the system or one system or part(s) thereof, containing these. Each material sample shall have the same appearance and surface treatment, if any, as intended for use in the system to be approved;
- 2.2.6. *the materials making up the lenses and coatings, if any, shall be accompanied by the test report of the characteristics of these materials and coatings if they have already been tested;*

- 2.2.7. *if the system is equipped with one or more light source modules: two samples of each light source module for inspection and/or testing according to paragraph ~~5.9.3~~ 5.9.2. of this Regulation;*
- 2.2.8. *if the system is equipped with one or more light source modules and/or lighting units which incorporate one or more light sources not being approved according to Regulation No. 37 or 99: two samples of each relevant light source module or lighting unit for inspection and/or testing according to the provisions of annex 8 to this Regulation;*
3. MARKINGS
- 3.1. *The installation units of a system submitted for approval shall bear the trade name or mark of the applicant.*
- 3.2. *They shall comprise each, on the lenses and on the main bodies spaces of sufficient size for the approval mark and the additional symbols referred to in paragraph 4.; these spaces shall be indicated on the drawings referred to in paragraph 2.2.1. above.*
- 3.2.1. *If however the lens cannot be detached from the main body of the installation unit, one marking as per 4.2.5. shall be sufficient.*
- 3.3. *The installation units or systems designed to satisfy the requirements both of right-hand and of left-hand traffic shall bear markings indicating the two settings of the optical element(s) on the vehicle or of the light source(s) on the reflector(s); these markings shall consist of the letters "R/D" for the position for right-hand traffic and the letters "L/G" for the position for left-hand traffic.*
- 3.4. *In the case of a system designed to meet the requirements set out in the paragraph ~~5.10.2.1~~ 5.8.2.1. below by means of, or using additionally an area on the front lens(es) of the installation unit(s) which can be occulted, this area must be outlined indelibly. This marking is not necessary, however, where the area is clearly apparent.*
- 3.5. *Each installation unit shall bear a clearly legible and indelible marking of the specific identification(s) of the one or more light source modules being part of it, if any;*
- 3.6. *The light source module(s) of a system shall bear a clearly legible and indelible marking comprising of:*
- 3.6.1. *the trade name or mark of the applicant;*

3.6.2. *the specific identification according paragraph 2.1.5.2., or, a space of sufficient size for the approval marking and the additional symbols prescribed in paragraph 4.2. below;*

3.6.3. *the rated voltage, except if it is driven by a supply and operation device not being part of the light source module.*

4. APPROVAL

4.1. General

4.1.1. If all the samples of a type of *a system* submitted pursuant to paragraph 2. above satisfy the provisions of this Regulation, approval shall be granted.

4.1.2. Where lamps being grouped, combined or reciprocally incorporated with the *system* satisfy the requirements of more than one Regulation, a single international approval mark may be affixed provided that each of the grouped, combined or reciprocally incorporated lamps satisfies the provisions applicable to it.

4.1.3. An approval number shall be assigned to each type approved. Its first two digits (at present 00) shall indicate the series of amendments incorporating the most recent major technical amendments made to the Regulation at the time of issue of the approval. The same Contracting Party may not assign the same number to another type of *system* covered by this Regulation.

4.1.4. Notice of approval or of extension or refusal or withdrawal of approval or production definitely discontinued of a type of *system* pursuant to this Regulation shall be communicated to the Parties to the 1958 Agreement applying this Regulation, by means of a form conforming to the model in annex 1 to this Regulation, with the indications according to paragraph 2.1.3.

4.1.4.1. if the *installation unit(s)* is/are equipped with an adjustable reflector and if this/*these installation unit(s)* is/are to be used only in mounting positions according to the indications in paragraph 2.1.3. the applicant shall be obliged by approval to inform the user in a proper way about the correct mounting position(s).

4.1.5. In addition to the mark prescribed in paragraph 3.1., an approval mark as described in paragraphs 4.2. and 4.3. below shall be affixed in the spaces referred to in paragraph 3.2. above to every *installation unit of a system* conforming to a type approved under this Regulation.

4.1.6. *The Applicant shall indicate in a form corresponding to the respective model in the annex 1 to this Regulation, the type(s) of vehicles for which the system is intended.*

4.1.7. If approval is sought for a system which is not intended to be included as part of the approval of a vehicle type according to Regulation No.48,

4.1.7.1. the Applicant shall demonstrate the capability of the system to comply with the relevant provisions of section 6.20. of Regulation No.48 when correctly installed, and

4.1.7.2. the system shall be approved according to Regulation No.10.

4.2. Composition of the approval mark

The approval mark shall consist of:

4.2.1. An international approval marking, comprising:

4.2.1.1. a circle surrounding the letter "E" followed by the distinguishing number of the country which has granted approval 4;

4.2.1.2. the approval number prescribed in paragraph 4.1.3. above;

4.2.2. the following additional symbol (or symbols):

4.2.2.1. *on a system, the letter "X", and those of the function(s) being provided by the system:*

"C" for the class C ~~(basic)~~ passing beam, with the addition of symbols for the relevant other classes of passing beam:

"E" for a class E passing beam,

"V" for a class V passing beam,

"W" for a class W passing beam;

"R" for a driving beam;

4/ 1 for Germany, 2 for France, 3 for Italy, 4 for the Netherlands, 5 for Sweden, 6 for Belgium, 7 for Hungary, 8 for the Czech Republic, 9 for Spain, 10 for Yugoslavia, 11 for the United Kingdom, 12 for Austria, 13 for Luxembourg, 14 for Switzerland, 15 (vacant), 16 for Norway, 17 for Finland, 18 for Denmark, 19 for Romania, 20 for Poland, 21 for Portugal, 22 for the Russian Federation, 23 for Greece, 24 for Ireland, 25 for Croatia, 26 for Slovenia, 27 for Slovakia, 28 for Belarus, 29 for Estonia, 30 (vacant), 31 for Bosnia and Herzegovina, 32 for Latvia, 33 (vacant), 34 for Bulgaria, 35-36 (vacant), 37 for Turkey, 38-39 (vacant), 40 for The former Yugoslav Republic of Macedonia, 41 (vacant), 42 for the European Community (Approvals are granted by its Member States using their respective ECE symbol), 43 for Japan, 44 (vacant), 45 for Australia, 46 for Ukraine, 47 for South Africa and 48 for New Zealand. Subsequent numbers shall be assigned to other countries in the chronological order in which they ratify or accede to the Agreement concerning the Adoption of Uniform Technical Prescriptions for Wheeled Vehicles, Equipment and Parts which can be Fitted and/or be Used on Wheeled Vehicles and the Conditions for Reciprocal Recognition of Approvals Granted on the Basis of these Prescriptions, and the numbers thus assigned shall be communicated by the Secretary-General of the United Nations to the Contracting Parties to the Agreement.

- 4.2.2.2. *in addition to each symbol and above it a score, if the lighting function or mode of is provided by more than one installation unit from one or both side(s);*
- 4.2.2.3. *in addition the symbol "T", after the symbol(s) of all lighting function(s) and/or class(es) designed to comply with the respective bend lighting provisions, with said symbol(s) arranged together and leftmost;*
- 4.2.2.4. *on a separate installation unit, the letter "X", and those of the function(s) being provided by the lighting unit(s) comprised in it;*
- 4.2.2.5. *if the installation unit on a given side is not the only contributor to a lighting function or mode of a lighting function it shall bear a score above the symbol of the function;*
- 4.2.2.6. *on a system or part thereof meeting left-hand traffic requirements only, a horizontal arrow pointing to the right of an observer facing the installation unit, i.e. to the side of the road on which the traffic moves;*
- 4.2.2.7. *on a system or part thereof designed to meet the requirements of both traffic systems e.g. by means of an appropriate adjustment of the setting of the optical element or the light source, a horizontal arrow with a head on each end, the heads pointing respectively to the left and to the right;*
- 4.2.2.8. *on an installation unit incorporating a lens of plastic material, the group of letters "PL" to be affixed near the symbols prescribed in paragraphs 4.2.2.1. to 4.2.2.7. above;*
- 4.2.2.9. *on an installation unit contributing to fulfill the requirements of this Regulation in respect of the driving beam, an indication of the maximum luminous intensity expressed by the reference mark, as defined in paragraph 6.3.2.1.3. below, placed near the circle surrounding the letter "E";*
- 4.2.3. In every case the relevant operating mode used during the test procedure according to paragraph 1.1.1.1. of annex 4 and the permitted voltage(s) according to paragraph 1.1.1.2. of annex 4 shall be stipulated on the approval forms and on the communication forms transmitted to the countries which are Contracting Parties to the Agreement and which apply this Regulation.

In the corresponding cases the *system or part(s) of* shall be marked as follows:

- 4.2.3.1. on an *installation unit* meeting the requirements of this Regulation which *is* so designed that the light source(s) of the passing beam (*if any*) shall not be lit simultaneously with that of any other lighting function with which it may be reciprocally incorporated: an oblique stroke (*/*) shall be placed *after* the passing *beam* symbol(s) in the approval mark.

- 4.2.3.2. on an *installation unit* meeting the requirements of annex 4 to this Regulation only when supplied with a voltage of 6 V or 12 V, a symbol consisting of the number 24 crossed out by an oblique cross (**X**), shall be placed near the holders of the light source(s).
- 4.2.4. The two digits of the approval number (at present 00) which indicate the series of amendments incorporating the most recent major technical amendments made to the Regulation at the time of issue of the approval and, if necessary, the required arrow may be marked close to the above additional symbols.
- 4.2.5. The marks and symbols referred to in paragraphs 4.2.1. and 4.2.2. above shall be clearly legible and be indelible. *They may be placed on an inner or outer part (transparent or not) of the installation unit which cannot be separated from its light-emitting surface(s). In any case it shall be visible when the installation unit(s) is/are fitted on the vehicle. The displacement of a movable part of the vehicle is permitted to fulfil this requirement.*
- 4.3. Arrangement of the approval mark
- 4.3.1. Independent lamps
- Annex 2, Figures 1 to 10, to this Regulation gives examples of arrangements of the approval mark with the above-mentioned additional symbols.
- 4.3.2. Grouped, combined or reciprocally incorporated lamps
- 4.3.2.1. Where *lamps being* grouped, combined or reciprocally incorporated *with the system* have been found to comply with the requirements of several Regulations, a single international approval mark may be affixed, consisting of a circle surrounding the letter "E" followed by the distinguishing number of the country which has granted the approval, and an approval number. This approval mark may be located anywhere on the grouped, combined or reciprocally incorporated lamps, provided that:
- 4.3.2.1.1. it is visible *as per paragraph 4.2.5.*;
- 4.3.2.1.2. no part of the grouped, combined or reciprocally incorporated lamps that transmits light can be removed without at the same time removing the approval mark.
- 4.3.2.2. The identification symbol for each lamp appropriate to each Regulation under which approval has been granted, together with the corresponding series of amendments incorporating the most recent major technical amendments to the Regulation at the time of issue of the approval, and if necessary, the required arrow shall be marked:
- 4.3.2.2.1. either on the appropriate light-emitting surface,

- 4.3.2.2.2. or in a group, in such a way that each of the grouped, combined or reciprocally incorporated lamps may be clearly identified (see for possible examples in annex 2).
- 4.3.2.3. The size of the components of a single approval mark shall not be less than the minimum size required for the smallest of the individual marks by the Regulation under which approval has been granted.
- 4.3.2.4. An approval number shall be assigned to each type approved. The same Contracting Party may not assign the same number to another type of grouped, combined or reciprocally incorporated lamps covered by this Regulation.
- 4.3.2.5. Annex 2, Figure 11 and 12, to this Regulation give examples of arrangements of approval marks for grouped, combined or reciprocally incorporated lamps with all the above-mentioned additional symbols, and relating *to a system with functions provided by more than one installation unit per side of the vehicle.*
- 4.3.2.6. Annex 2, Figure 13, to this Regulation give examples of approval marks relating to the complete *system.*

B. TECHNICAL REQUIREMENTS FOR SYSTEMS OR PART(S) OF A SYSTEM

Unless otherwise specified, photometric measurements shall be carried out according to the provisions set out in the annex 10 to this Regulation.

5. GENERAL SPECIFICATIONS

- 5.1. Each sample, when its approval is sought for right-hand traffic only, shall conform to the specifications set forth in paragraphs 6. to 7. below; *if however its approval is sought for left-hand traffic, the provisions of paragraphs 6. to 7. below, including the relevant annexes to this Regulation, apply with the inversion of right to left and vice versa*
- 5.1.2. *Systems or part(s) thereof, shall be so made as to retain their prescribed photometric characteristics and to remain in good working order when in normal use, in spite of the vibrations to which they may be subjected.*
- 5.2. *Systems or part(s) thereof, shall be fitted with a device enabling them to be so adjusted on the vehicle as to comply with the rules applicable to them.*
- 5.2.1. *Such adjustment device(s) need not be fitted on systems or part(s) thereof, provided that their use is confined to vehicles on which the setting can be adjusted by other means or no such means are needed according to the Applicant's system description.*

- 5.3. ***The system shall be equipped with light sources as defined in paragraph 5.3.1. through 5.3.4. below, or any combination of them;***
- 5.3.1. *one or more replaceable light sources approved according to Regulation No. 37 or 99, where the lamp holder shall conform to the dimensional characteristics given on the data sheet of IEC Publication No. 60061-2, as referred to in the relevant light source Regulation;*
- 5.3.2. ***one or more non-replaceable light sources, where the respective lighting unit must be so designed that said light source(s) cannot be removed without destroying the unit or at least one essential optical element of it;***
- 5.3.3. *one or more light source modules,*
- 5.3.4. *one or more light-generators.*
- 5.4. *System(s) or part(s) thereof, designed to satisfy the requirements both of right-hand and of left-hand traffic may be adapted for traffic on a given side of the road either by an appropriate initial setting when fitted on the vehicle or by selective setting by the user. In any case, only two different and clearly distinct settings, one for right-hand and one for left-hand traffic, shall be possible, and the design shall preclude inadvertent shifting from one setting to the other or setting in an intermediate state.*
- 5.5. Complementary tests shall be done according to the requirements of annex 4 *of this Regulation* to ensure that in use there is no excessive change in photometric performance.
- 5.6. If the lens of a *lighting unit* is of plastic material, tests shall be done according to the requirements of annex 6 *to this Regulation*.
- 5.7. On a *system or part(s) of*, designed to provide alternately *the driving beam* and *the passing beam*, any mechanical, electro-mechanical or other device incorporated in the *lighting unit(s)*, for switching from one to the other beam shall be so constructed that:
- 5.7.1. the device is strong enough to withstand 50 000 operations without suffering damage despite the vibrations to which it may be subjected in normal use;
- 5.7.2. either the passing beam or the driving beam shall always be obtained, without any possibility of *remaining in an intermediate or undefined state*; *if this is not possible, such a state must be covered by the provisions according to paragraph 5.7.3. below*;
- 5.7.3. in the case of failure it must be possible to obtain automatically *a passing beam or a state with respect to the photometric conditions which yields values not exceeding*

1.5 lx in the zone III b as defined in annex 3 to this Regulation, by such means as e.g. switching off, dimming, aiming downwards, and/or functional substitution;

5.7.4. the user cannot, with ordinary tools, change the shape or position of the moving parts, or influence the switching device.

5.8. ~~5.10.~~ Systems shall provide means allowing them to be used temporarily in a territory with the opposite direction of driving than that for which approval is sought, without causing undue dazzle to the oncoming traffic. For these purposes the system(s) or part(s) thereof shall:

5.8.1. ~~5.10.1.~~ be capable of providing a selective setting by the user according to paragraph 5.4. above, without special tools; or

5.8.2. ~~5.10.2.~~ provide means to achieve a traffic-change **function**, producing not more than 1.5 lx in zone IIIb for the opposite direction of traffic and not less than 6lx in 50V when tested according to paragraph 6.2. below with the adjustment left unchanged compared to that for the original traffic direction; where

5.8.2.1. ~~5.10.2.1.~~ the occultation of a respective lens area according to paragraph 3.4. above may be such means or part of it.

5.9. Further provisions:

5.9.1. The system shall be so made that:
if a light source has failed, a failure signal in order to comply with the relevant provisions of Regulation No.48 shall be provided.

5.9.2. ~~5.9.3.~~ The system shall be so made, that a light source module is secure and safe in position, orientation and fixation; this shall be verified by re-placing the light source module and testing compliance with the photometric requirements of each passing beam mode(s), if it applies.

5.10. ~~5.11.~~ The component(s) to which a replaceable light source or a light source module is assembled shall be so made that the light source or the light source module fits easily and, even in darkness, can be fitted in no position but the correct one.

5.11. ~~5.12.~~ The requirements of annex 8 to this regulation apply to lighting units containing non-approved light sources.

6. ILLUMINATION

6.1. General provisions

- 6.1.1. *Each system shall provide a class C (~~basic~~) passing beam according to paragraph 6.2.5. below **and one or more additional class(es) of passing beam; it may incorporate one or more additional modes** within each class of passing beam and the front-lighting functions according to paragraph 6.3. and/or 2.1.1.1. of this Regulation.*
- 6.1.2. *The system shall provide automatic modifications, such, that good road illumination is achieved and no discomfort is caused, neither to the driver nor to other road users.*
- 6.1.3. *The system shall be considered acceptable if it meets the relevant photometric requirements of paragraphs 6.2. **and 6.3.** .*
- 6.1.4. *Photometric measurements shall be performed according to the Applicants description:*
- 6.1.4.1. *at neutral state according to paragraph 1.9. ;*
- 6.1.4.2. *at V-signal, W-signal, E-signal, T-signal according to paragraph 1.10., whichever apply;*
- 6.1.4.3. *if applicable, at any other signal(s) according to paragraph 1.10. and combinations of them, according to the Applicant's specification.*
- 6.2. Provisions concerning passing beam
- The system shall, prior to the subsequent test procedures, be set to the neutral state, emitting the class C (~~basic~~) passing beam.*
- 6.2.1. *The class C (~~basic~~) passing beam shall produce a "cut-off" as defined in annex 9 to this Regulation, which is sufficiently sharp and permits aiming for each side of the system.*
- 6.2.1.1. *Annex 9 does not apply to the traffic-change function as described in paragraph 5.8. **through 5.8.2.1.** above.*
- 6.2.2. *The system or part(s) thereof shall be so aimed that the position of the cut-off complies with the requirements indicated in the Table 2 of annex 3 to this Regulation.*
- 6.2.3. *When so aimed, the system or part(s) thereof, if its approval is sought solely for provision of the passing beam, needs to comply with the requirements set out in the relevant paragraphs below; if it is intended to provide additional lighting or light signalling functions according to the scope of this Regulation, it shall comply in addition with the requirements set out in the relevant paragraphs below, if not being adjustable independently.*

- 6.2.4. Where a system or any part(s) thereof so aimed do not meet the requirements as indicated in paragraph 6.2.3. above, its alignment may, *according to the instructions of the manufacturer*, be changed, *within 0.5 deg to the right or left and vertically 0.2 deg up or down*, with respect to the initial aiming.
- 6.2.5. *When emitting a specified mode of the passing beam, the system shall meet the requirements laid down in the respective section (C, V, E, W) of part A of Table 1 (photometric values) and in Table 2 (E_{max} and "cut-off" positions) of annex 3 to this Regulation, as well as section 1 ("cut-off" shape) of annex 9 to this Regulation.*
- 6.2.6. *A bending mode may be emitted, provided that:*
- 6.2.6.1. *the system meets the respective requirements of part B of Table 1 (photometric values) and item 2 of Table 2 ("cut-off" provisions) of annex 3 to this Regulation, when measured according to the procedure indicated in annex 10, relevant to the category (either category 1 or category 2) of the bending mode, for which approval is sought;*
- 6.2.6.2. *E_{max} of the illumination does not lie outside of the rectangle extending from the uppermost vertical position specified in Table 2 of annex 3 to this Regulation for the respective passing beam class, to 2 deg below H-H and from 45 deg left to 45 deg right of the system reference axis;*
- 6.2.6.3. *if the T-signal corresponds to the vehicle's smallest turn radius to the left (or right), the system provides at least 3 lx at one or more points in the zone extending from H-H to 2 deg below H-H and from 10 to 45 deg left (or right) of the system reference axis;*
- 6.2.6.4. *if approval is sought for a category 1 bending mode, the use of the system is restricted to vehicles where provisions are taken that in case of a turn to the left (to the right for Left Traffic) the position of the "kink" of the "cut-off" which is provided by the system, complies with the relevant provisions of paragraph 6.20.7.2. of Regulation No. 48,*
- 6.2.6.5. *if approval is sought for a category 1 bending mode, the system is designed so, that in the case of a failure affecting the lateral movement or modification of the illumination, it must be possible to obtain automatically either photometric conditions corresponding to paragraph 6.2.5. above or a state with respect to the photometric conditions which yields values not exceeding 1.5 lx in the zone IIIb, as defined in annex 3 to this Regulation,*
- 6.2.6.5.1. *however this is not needed, if for positions, relative to the system reference axis up to 5 deg left, at 0.3 deg up from H-H, and greater than 5 deg left, at 0.57 deg up, (opposite for left-hand traffic) a value of 1 lx is in no case exceeded.*
- 6.2.7. *The system shall be checked on the basis of the relevant instructions of the manufacturer, indicated in the safety concept according to paragraph 2.2.2.1. above.*

- 6.2.8. *A system or part(s) thereof, designed to meet the requirements of both right-hand and left-hand traffic must, in each of the two setting positions, according to 5.4. above meet the requirements specified for the corresponding direction of traffic.*
- 6.2.9. The system shall be so made that:
- 6.2.9.1. *any specified passing beam mode provides at least 3lx at point 50V from each side of the system;
the Class V passing beam is exempted.*
- 6.2.9.2. *four seconds after switching on the system, which has not been operated for 30 minutes or more, at least 5lx must be reached at point 50V of the class C ~~(basic)~~ passing beam;*
- 6.2.9.3. *other modes:*
- when signal inputs according to paragraph 6.1.4.3. of this Regulation apply, the requirements of the paragraph 6.2. shall be fulfilled.*
- 6.3. Provisions concerning driving beam
- The system shall, prior to the subsequent test procedures, be set to the neutral state.*
- 6.3.1. *The lighting unit(s) of the system shall be adjusted, according to the instructions of the manufacturer, such that the area of maximum illumination is centered on the point (HV) of intersection of the lines H-H and V-V;*
- 6.3.1.1. *any lighting unit(s) which is/are not independently adjustable, or, for which the aiming was done with respect to any measurements under paragraphs 6.2., shall be tested in its/their unchanged position.*
- 6.3.2. *When measured according to the provisions laid down in annex 10 to this Regulation the illumination shall meet the following requirements.*
- 6.3.2.1. HV shall be situated within the isolux 80 per cent of maximum illumination *of the driving beam.*
- 6.3.2.1.1. This maximum value (E_M) shall not be less than 48lx. The maximum value shall in no circumstances exceed 240lx;
- 6.3.2.1.2. The maximum intensity (I_M) of each installation unit providing or contributing to the maximum intensity of the driving beam, expressed in thousands of candelas shall be calculated by the formula:

$$I_M = 0.625 E_M$$

- 6.3.2.1.3. The reference mark (I'_M) of this maximum intensity, referred to in paragraph 4.2.2.9. above, shall be obtained by the ratio:

$$I'_M = \frac{I_M}{3} = 0,208 E_M.$$

This value shall be rounded off to the value of: 5 - 10 - 12.5 - 17.5 - 20 - 25 - 27.5 - 30 - 37.5 - 40 - 45 - 50.

- 6.3.2.2. Starting from point HV, horizontally to the right and left, the illumination of the *driving beam* shall be not less than 24lx up to 2.6 deg and not less than 6lx up to 5.2 deg.
- 6.3.3. *The illumination or part thereof emitted by the system may be automatically laterally moved (or modified to obtain an equivalent effect), provided that:*
- 6.3.3.1. *the system meets the requirements of the paragraphs 6.3.2.1.1. and 6.3.2.2. above with each lighting unit measured according to the relevant procedure indicated in annex 10.*
- 6.3.4. The system shall be so made that:
- 6.3.4.1. *the lighting unit(s) of the right side and of the left side provide each at least half of the minimum illumination value of the driving beam as specified by the paragraph 6.3.2.2. above:*
- 6.3.4.2. *four seconds after switching on the system, which has not been operated for 30 minutes or more, at least 42lx must be reached at point HV of the driving beam;*
- [6.3.4.3. *When signal inputs according to paragraph 6.1.4.3. of this Regulation apply, the requirements of the paragraph 6.3. shall be fulfilled.*]
- 6.3.5. *If the specified beam requirements are not met, a re-aiming of the beam position within 0.5deg up or down and/or 1 deg to the right or left, with respect to its initial aiming is allowed; in the revised position all photometric requirements shall be met.*

These provisions do not apply to lighting units as indicated under paragraph 6.3.1.1. of this Regulation.

6.4. ~~6.5~~ Other provisions

In the case of a system or part(s) thereof with adjustable lighting units the requirements of paragraphs 6.2. (passing beam), and 6.3. (driving beam) are applicable for each mounting position indicated according to paragraph 2.1.3. (adjustment range). For verification the following procedure shall be used:

- 6.4.1. ~~6.5.1.~~ Each applied position is realized on the test goniometer with respect to a line joining the *centre of reference* and point HV on an aiming screen. The adjustable *system or part(s) thereof* is then moved into such a position that the light pattern on the screen corresponds to the *relevant* aiming prescriptions;
- 6.4.2. ~~6.5.2.~~ with the *system or part(s) thereof* initially fixed according to paragraph 6.4.1., the *device or part(s) thereof* must meet the relevant photometric requirements of paragraphs 6.2. and 6.3.;
- 6.4.3. ~~6.5.3.~~ additional tests *shall be* made after the *reflector/system or part(s) thereof* has been moved vertically ± 2 deg or at least into the maximum position if less than 2 deg, from its initial position by means of the *system or part(s) thereof* adjusting device. Having re-aimed the *system or part(s) thereof* as a whole (by means of the goniometer for example) in the corresponding opposite direction the light output in the following directions shall be controlled and lie within the required limits:
- 6.4.3.1. ~~6.5.3.1.~~ passing beam: points HV and 75 R, or 50R if applicable; *driving beam*: I_M and point HV (percentage of I_M);
- 6.4.4. ~~6.5.4.~~ if the applicant has indicated more than one mounting position, the procedure of paragraphs 6.4.1. to 6.4.3. shall be repeated for all other positions;
- 6.4.5. ~~6.5.5.~~ if the applicant has not asked for special mounting positions, the *system or part(s) thereof* shall be aimed for measurements of paragraphs 6.2. (*passing beam*) and 6.3. (*driving beam*) with the *relevant* adjusting device(s) of the *system or part(s) thereof* in its mean position. The additional test of paragraph 6.4.3. shall be made with the *system or part(s) thereof*, moved into its extreme positions (instead of ± 2 deg) by means of the *relevant* adjusting device(s).
- 6.4.6. ~~6.5.6.~~ It shall be stated by means of a form conforming to the model in annex 1 to this Regulation,
- ~~6.4.6.1.~~ ~~6.5.6.1.~~ which lighting unit(s) provide a "cut-off" as defined in Annex 9 of this Regulation, that projects into a zone extending from 8 [5] deg left to 8 [5] deg right and upwards from a horizontal line positioned at 0.9 [0.8] deg down, and
- 6.4.7. ~~6.5.7.~~ Lighting units containing light sources other than filament lamps or gas-discharge light sources shall be checked for compliance with the photometric [and colorimetric] provisions of this regulation both after one minute and 30 minutes of operation.

7. COLOUR

7.1 The colour of the light emitted shall be white. Expressed in CIE trichromatic coordinates, the light *emitted by each part of the system* shall be in the following boundaries:

- limit towards blue $x \geq 0.310$
- limit towards yellow $x \leq 0.500$
- limit towards green $y \leq 0.150 + 0.640 x$
- limit towards green $y \leq 0.440$
- limit towards purple $y \geq 0.050 + 0.750 x$
- limit towards red $y \geq 0.382$

C. FURTHER ADMINISTRATIVE PROVISIONS

8. MODIFICATION OF THE SYSTEM TYPE AND EXTENSION OF APPROVAL

8.1. Every modification of the *system* type shall be notified to the administrative department which approved the *system* type. The said department may then either:

8.1.1. Consider that the modifications made are unlikely to have appreciable adverse effects and that in any event the *system* still complies with the requirements; or

8.1.2. Require a further test report from the Technical Service responsible for conducting the tests.

8.2. Confirmation or refusal of approval, specifying the alterations, shall be communicated by the procedure specified in paragraph 4.1.4. above to the Parties to the Agreement which apply this Regulation.

8.3. The competent authority issuing the extension of approval shall assign a series number to each communication form drawn up for such an extension and inform thereof the other Parties to the 1958 Agreement applying this Regulation by means of a communication form conforming to the model in annex 1 to this Regulation.

9. CONFORMITY OF PRODUCTION

The conformity of production procedures shall comply with those set out in the Agreement, Appendix 2 (E/ECE/324-E/ECE/TRANS/505/Rev.2) with the following requirements:

9.1. a *system* approved under this Regulation shall be so manufactured as to conform to the type approved by meeting the requirements set forth in paragraphs 6. and 7.

9.2. the minimum requirements for conformity of production control procedures set forth in annex 5 to this Regulation shall be complied with.

- 9.3. The minimum requirements for sampling by an inspector set forth in annex 7 to this Regulation shall be complied with.
- 9.4. The authority which has granted type approval may at any time verify the conformity control methods applied in each production facility. The normal frequency of these verifications shall be once every two years.
- 9.5. Systems or part(s) thereof with apparent defects are disregarded.
- 9.6. The reference mark is disregarded.

10. PENALTIES FOR NON-CONFORMITY OF PRODUCTION

- 10.1. The approval granted in respect of a type of *system* pursuant to this Regulation may be withdrawn if the requirements are not complied with or if a *system or part(s) thereof* bearing the approval mark does not conform to the type approved.
- 10.2. If a Contracting Party to the Agreement applying this Regulation withdraws an approval it has previously granted, it shall forthwith so notify the other Contracting Parties applying this Regulation by means of a communication form conforming to the model in annex 1 to this Regulation.

11. PRODUCTION DEFINITELY DISCONTINUED

If the holder of the approval completely ceases to manufacture a type of *system* approved in accordance with this Regulation, he shall so inform the authority, which granted the approval. Upon receiving the relevant communication, that authority shall inform thereof the other Parties to the 1958 Agreement applying this Regulation by means of a communication form conforming to the model in annex 1 to this Regulation.

12. NAMES AND ADDRESSES OF TECHNICAL SERVICES RESPONSIBLE FOR CONDUCTING APPROVAL TESTS, AND OF ADMINISTRATIVE DEPARTMENTS

The Parties to the 1958 Agreement applying this Regulation shall communicate to the United Nations Secretariat the names and addresses of the technical services responsible for conducting approval tests and of the administrative departments which grant approval and to which forms certifying approval or extension or refusal or withdrawal of approval, or production definitely discontinued, issued in other countries, are to be sent.

Annex 1

COMMUNICATION

maximum format: A4 (210 x 297 mm)

issued by: Name of administration:
.....
.....
.....



concerning: 2/ APPROVAL GRANTED
APPROVAL EXTENDED
APPROVAL REFUSED
APPROVAL WITHDRAWN
PRODUCTION DEFINITELY DISCONTINUED

of a type of *system* pursuant to Regulation No.

Approval No. Extension No.

1. Trade name or mark of the *system*:
2. Manufacturer's name for the type of *system*:
3. Manufacturer's name and address:
4. If applicable, name and address of manufacturer's representative:
.....
5. Submitted for approval on:
6. Technical service responsible for conducting approval tests:
.....
7. Date of report issued by that service:
8. Number of report issued by that service:
9. Brief description:
 - 9.1. Category as described by the relevant marking 3/

1/ Distinguishing number of the country which has granted/ extended/ refused/ withdrawn approval (see the provisions of the Regulation concerning approval)

2/ Strike out what does not apply.

3/ Indicate the appropriate marking as foreseen according to this Regulation for each *installation unit* or *assembly of installation units*.

- 9.2. Number and category(ies) of *replaceable light sources*:.....
- 9.3. *The specific identification(s) of*
- 9.3.1. *the one or more light source modules(s) equipped with light sources not being approved according to Regulation No. 37 or 99 and indication of the respective lighting unit(s):*
- 9.3.2. *any other lighting unit(s) which incorporate one or more light sources not being approved according to Regulation No. 37 or 99, if any:*
- 9.4. *Indications according to paragraph 6.4.6. of this Regulation:*
which lighting unit(s) provide a "cut-off" as defined in Annex 9 of this Regulation, that projects into a zone extending from 8[5] deg left to 8[5] deg right and upwards from a horizontal line positioned at 0.9[0.8] deg down:
- ~~9.5. Conformity to paragraph 5.9.1. by means of the system yes/no~~
- ~~9.6. Traffic change function, if any: Conformity to paragraph 5.4.1. of this Regulation by means of the system yes/no~~
10. Approval mark(s) position(s):
11. Reason(s) for extension of approval:
12. Approval granted / extended / refused / withdrawn 4/
13. Place:
14. Date:
15. Signature:
16. The list of documents deposited with the Administrative Service, which has granted approval is annexed to this communication and may be obtained on request.

4/ Strike out what does not apply.

17. The system is designed to provide **passing beams** of: 5/

17.1. **Class C 9** Class V Ω Class E Ω Class W Ω

17.2. with the following **mode(s)**, identified by the designation(s), if it applies 7/

No. C 1	No. V ...	No. E ...	No. W ...
No. C ...	No. V ...	No. E ...	No. W ...
No. C ...	No. V ...	No. E ...	No. W ...

17.3. where the **lighting units**, indicated below are energized 5/, 6/, 7/ for the mode No.

a) if no bend lighting applies:

left side	No.1 Ω	No.3 Ω	No.5 Ω	No.7 Ω	No.9 Ω	No.11 Ω
right side	No.2 Ω	No.4 Ω	No.6 Ω	No.8 Ω	No.10 Ω	No.12 Ω

b) if bend lighting of category 1 applies:

l.s.	No.1 Ω	No.3 Ω	No.5 Ω	No.7 Ω	No.9 Ω	No.11 Ω
r.s.	No.2 Ω	No.4 Ω	No.6 Ω	No.8 Ω	No.10 Ω	No.12 Ω

c) if bend lighting of category 2 applies:

l.s.	No.1 Ω	No.3 Ω	No.5 Ω	No.7 Ω	No.9 Ω	No.11 Ω
r.s.	No.2 Ω	No.4 Ω	No.6 Ω	No.8 Ω	No.10 Ω	No.12 Ω

Indications according to paragraph 17.3. a) through 17.3. c) above are needed additionally for each further mode.

17.4. The lighting units marked below with an X are energized, when the system is in its **neutral state** 5/, 6/

l.s.	No.1 Ω	No.3 Ω	No.5 Ω	No.7 Ω	No.9 Ω	No.11 Ω
r.s.	No.2 Ω	No.4 Ω	No.6 Ω	No.8 Ω	No.10 Ω	No.12 Ω

17.5. The lighting units marked below with an X are energized, when the system is in its **traffic change function** 5/, 6/, 7/

a) if no bend lighting applies:

l.s.	No.1 Ω	No.3 Ω	No.5 Ω	No.7 Ω	No.9 Ω	No.11 Ω
r.s.	No.2 Ω	No.4 Ω	No.6 Ω	No.8 Ω	No.10 Ω	No.12 Ω

b) if bend lighting of category 1 applies:

l.s.	No.1 Ω	No.3 Ω	No.5 Ω	No.7 Ω	No.9 Ω	No.11 Ω
r.s.	No.2 Ω	No.4 Ω	No.6 Ω	No.8 Ω	No.10 Ω	No.12 Ω

c) if bend lighting of category 2 applies:

l.s.	No.1 Ω	No.3 Ω	No.5 Ω	No.7 Ω	No.9 Ω	No.11 Ω
r.s.	No.2 Ω	No.4 Ω	No.6 Ω	No.8 Ω	No.10 Ω	No.12 Ω

- 5/ *mark with an X what applies*
- 6/ *to be extended if more units being provided*
- 7/ *to be continued if more modes being provided*

18. The system is designed to provide a **main beam**: 5/, 6/, 7/

18.1. yes Ω no Ω

18.2. with the following **mode(s)**, identified by the designation(s), if it applies:

main beam mode No. M 1

main beam mode No. M ...

main beam mode No. M ...

18.3. where the **lighting units** marked below with an X are energized, for mode No.

a) if no bend lighting applies:

l.s.	No.1 Ω	No.3 Ω	No.5 Ω	No.7 Ω	No.9 Ω	No.11 Ω
r.s.	No.2 Ω	No.4 Ω	No.6 Ω	No.8 Ω	No.10 Ω	No.12 Ω

b) if bend lighting applies:

l.s.	No.1 Ω	No.3 Ω	No.5 Ω	No.7 Ω	No.9 Ω	No.11 Ω
r.s.	No.2 Ω	No.4 Ω	No.6 Ω	No.8 Ω	No.10 Ω	No.12 Ω

Indications according to paragraph 18.3. a) and 18.3. b) above are needed additionally for each further mode.

18.4. The lighting units marked below with an X are energized, when the system is in its **neutral state** 5/, 6/

l.s.	No.1 Ω	No.3 Ω	No.5 Ω	No.7 Ω	No.9 Ω	No.11 Ω
r.s.	No.2 Ω	No.4 Ω	No.6 Ω	No.8 Ω	No.10 Ω	No.12 Ω

5/ mark with an X what applies
6/ to be extended if more units being provided
7/ to be continued if more modes being provided

Annex 2

EXAMPLES OF ARRANGEMENTS OF APPROVAL MARKS

a ≥ 8 mm (glass lens)
a ≥ 5 mm (plastic lens)

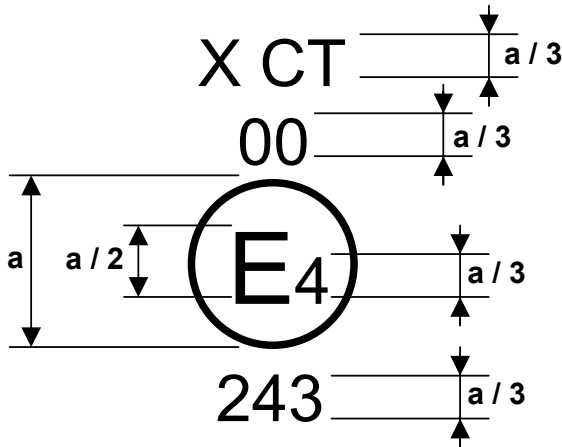

Figure 1

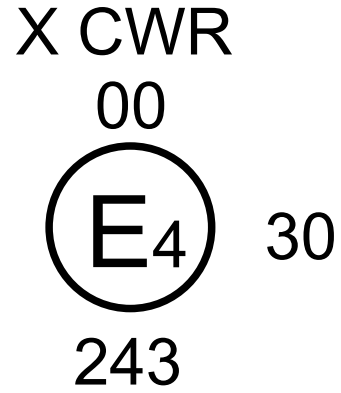
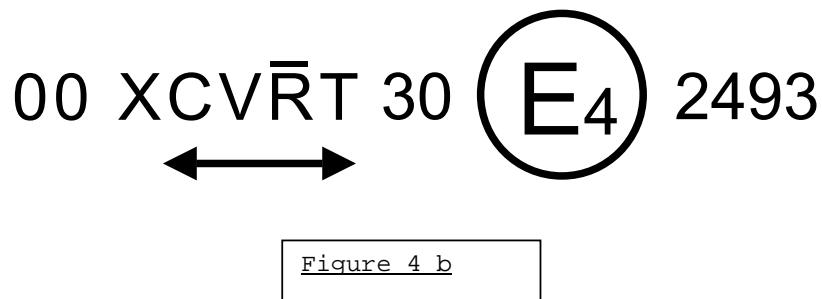
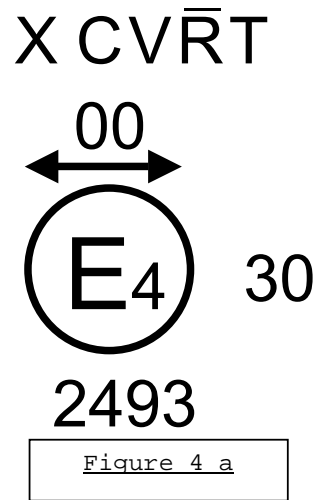
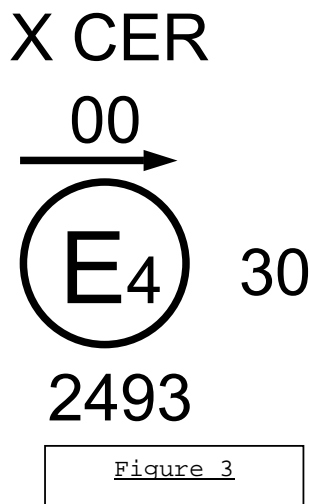

Figure 2

The installation unit of a system, bearing one of the above approval marks has been approved in the Netherlands (E 4) pursuant to ~~this~~ Regulation ~~No. XXX~~ under approval number 243, meeting the requirements of this Regulation in its original form (00). The passing beam is designed for right-hand traffic only. The letters "CT" (Figure 1) indicate that it concerns a passing beam with bending mode and the letters "CWR" (Figure 2) indicate that it concerns a class C (~~basic~~) passing beam and a class W passing beam and a driving beam.

Number 30 indicates that the maximum luminous intensity of the driving beam is between 86 250 and 101250 candelas.

Note: The approval number and additional symbols shall be placed close to the circle surrounding the letter 'E' and either above or below that letter 'E', or to the right or left of that letter. The digits of the approval number shall be on the same side of that letter 'E' and face in the same direction. The use of Roman numerals as approval numbers should be avoided so as to prevent any confusion with other symbols.



The installation unit of a system, bearing the above approval mark meets the requirements of this Regulation in respect of both the passing beam and the driving beam and is designed:

Figure 3: class C ~~(basic)~~ passing beam with class E passing beam for left-hand traffic only.

Figures 4a and 4b: class C ~~(basic)~~ passing beam with class V passing beam for both traffic systems by means of an appropriate adjustment of the setting of the optical element or the light source on the vehicle, and a driving beam. Class C ~~(basic)~~ passing beam and driving beam comply to bending lighting provisions, as indicated by the letter "T". The score above "R" indicates that the driving beam function is provided by more than one installation unit on that side of the system.

X CW PL

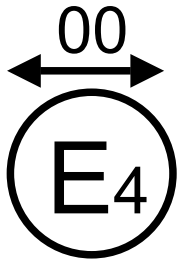

2493

Figure 5

X CT PL

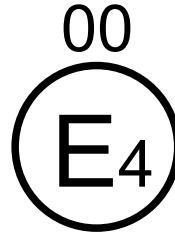

2493

Figure 6

The installation unit, bearing the above approval mark is incorporating a lens of plastic material and meeting the requirements of this Regulation in respect of the passing beam only and is designed:

Figure 5: class C ~~(basic)~~ passing beam and class W passing beam for both traffic systems.

Figure 6: class C ~~(basic)~~ passing beam with bending mode for right-hand traffic only.

X CV

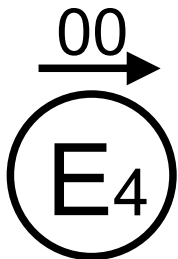

2493

Figure 7

00 X R



30

2493

Figure 8

Figure 7: the installation unit, bearing this ~~above~~ approval mark is meeting the requirements of this Regulation in respect of the class C ~~(basic)~~ passing beam with class V passing beam and designed for left-hand traffic only.

Figure 8: the installation unit, bearing this above approval mark is a (separate) installation unit of a system, meeting the requirements of this Regulation in respect of the driving beam only.

The identification of an installation unit incorporating a lens of plastic material meeting the requirements of this Regulation:

X CWT/R PL

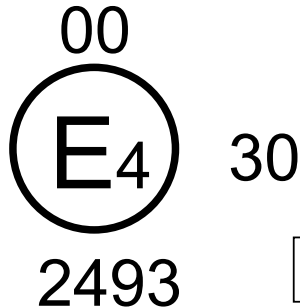

~~X CE/RL PL~~

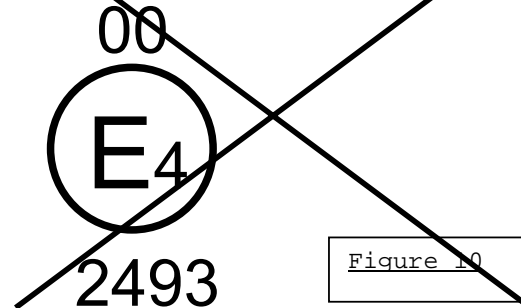

Figure 9: in respect to the class C (~~basic~~) passing beam the class W passing beam both with bending modes and a driving beam, and designed for right-hand traffic only.

~~Figure 10: in respect to the class C (~~basic~~) passing beam with class E passing beam, designed for right hand traffic only, and a daytime running light.~~

The passing beam and its modes shall not be operated simultaneously with the driving beam in Figure 9, ~~and the daytime running light in Figure 10~~, and/or another reciprocally incorporated headlamp.

Simplified marking for grouped, combined or reciprocally incorporated lamps, when approved according to other than this Regulation (Figure 11):

(The vertical and horizontal lines schematise the shape of the light-signalling device. They are not part of the approval mark).

These two examples correspond to two installation units on one side of a system, bearing an approval mark comprising:

Installation unit 1

A front position lamp approved in accordance with the 02 series of amendments of Regulation No. 7;

One or more lighting unit(s), with a class C (~~basic~~) passing beam with bending mode designed for right- and left-hand traffic provided to work with one or more other installation unit(s) on the same side of the system (as indicated by the score above "C") and a driving beam with a maximum intensity comprised between 86250 and 101250 candelas (as indicated by the number 30), approved in accordance with the requirements of this Regulation in its original form (00) and incorporating a lens of plastic material;

A front fog lamp approved in accordance with the 02 series of amendments to Regulation No. 19 and incorporating a lens of plastic material, in Model A

~~A daytime running light approved in accordance with the 00 series of amendments to this Regulation and incorporating a lens of plastic material, in Model B;~~

A front direction indicator lamp of category 1a approved in accordance with the 01 series of amendments to Regulation No. 6.

Installation unit 2

One or more lighting unit(s), with a class C (~~basic~~) passing beam with bending mode, designed for right- and left-hand traffic, provided to work with one or more other installation unit(s) on that side of the system, as indicated by the score above "C".

Installation unit 1 of the system

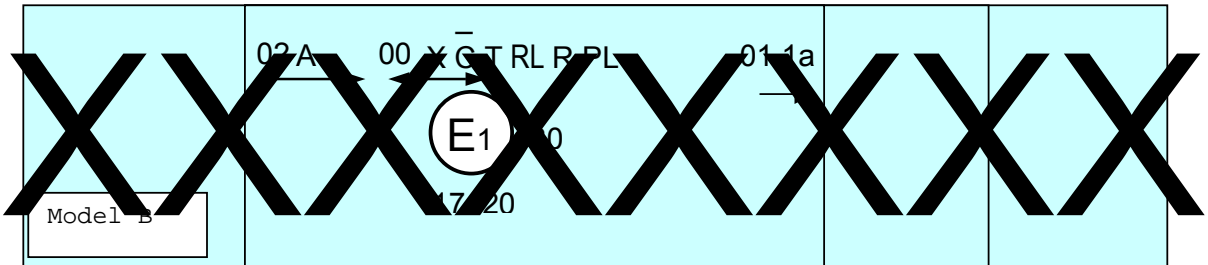
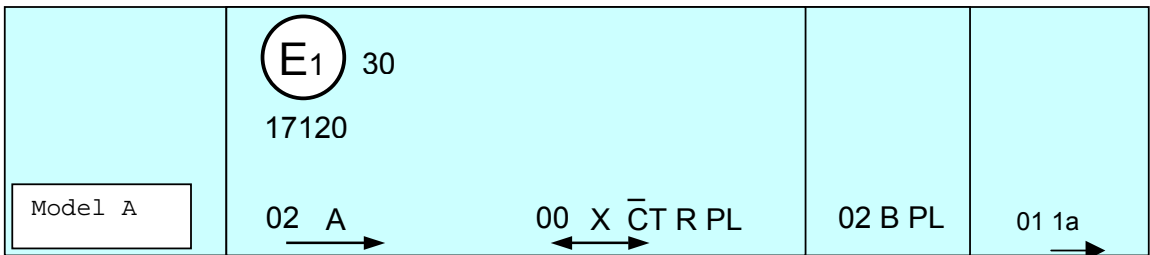

Installation unit 2 of the system

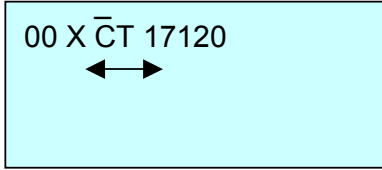

Figure 11

Arrangement of approval marks relative to an adaptive front-lighting system (Figure 12):

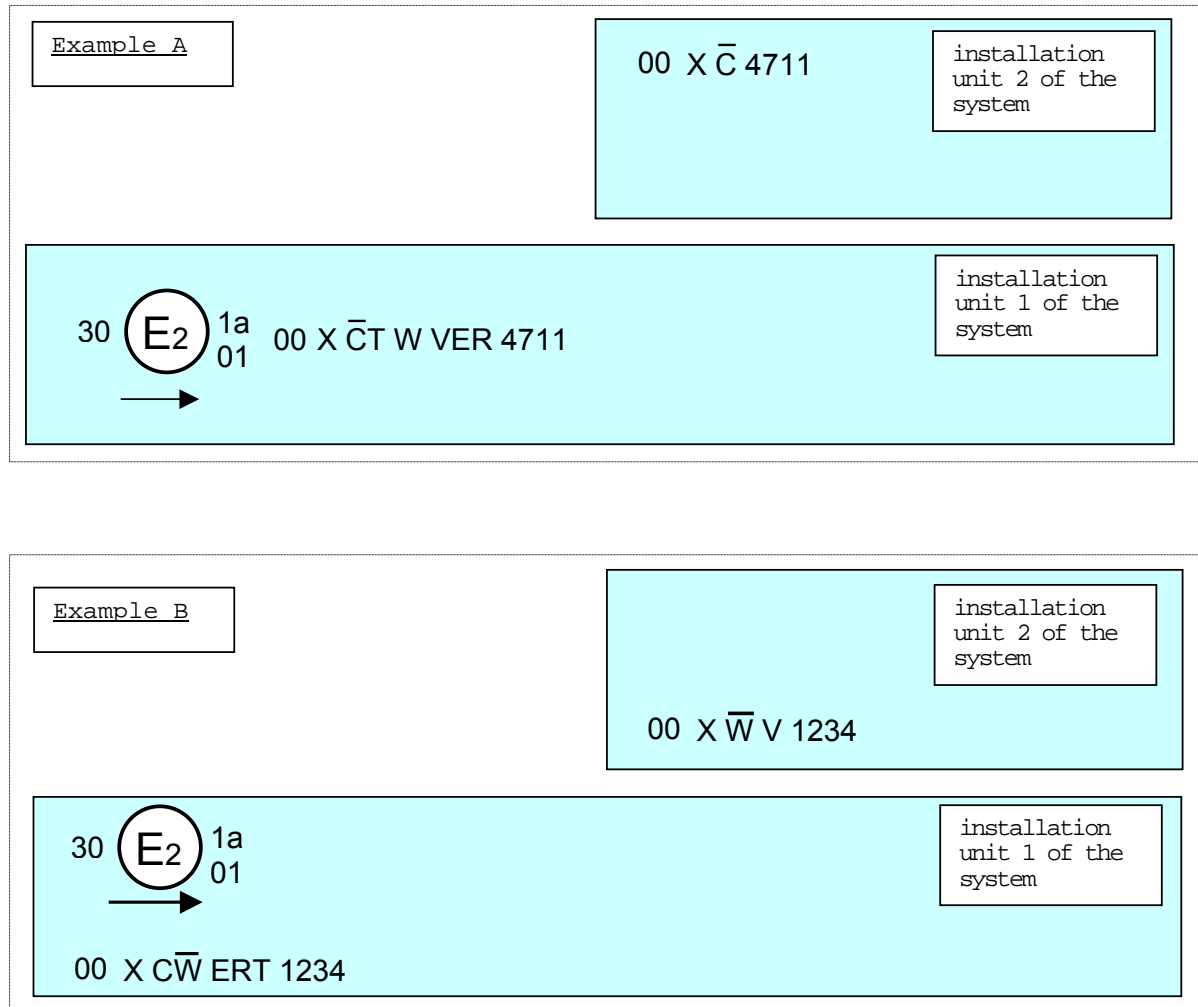

Figure 12

These two examples correspond to an adaptive front-lighting system composed of two installation units per side of the system.

The installation unit 1 of the system bearing the above approval marks meeting the requirements of this Regulation (00 series of amendments) in respect of both a class C ~~(basic)~~ passing beam for left-hand traffic and a driving beam with a maximum luminous intensity comprised between 86 250 and 101 250 candelas (indicated by the number 30), grouped with a front direction indicator lamp of category 1a, approved in accordance with the 01 series of amendments of Regulation No. 6.

In example **A**: the installation unit 1 of the system comprises a class C ~~(basic)~~ passing beam with bending mode, a class W passing beam, a class V passing beam and a class E passing beam. The score above "C" indicates that the class C ~~(basic)~~ passing beam is provided by two installation units on that side of the system.

The installation unit 2 is designed to provide a second part of the class C ~~(basic)~~ passing beam on that side of the system as indicated by the score above "C".

In example **B**: the installation unit 1 of the system is designed to provide a class C ~~(basic)~~ passing beam, a class W passing beam and a class E passing beam. The score above "W" indicates that the class W passing beam is provided by two installation units on that side of the system. The letter "T" to the right, following the listed symbols (and left of the approval number) indicates that each, the class C ~~(basic)~~ passing beam, the class W passing beam, the class E passing beam, and the driving beam are providing a bending mode.

The installation unit 2 of the system is designed to provide the second part of the class W passing beam on that side of the system (as indicated by the score above "W"), and the class V passing beam.

In the above two examples (Figures 11 and 12) the different installation units shall bear the same approval number.

Arrangement of approval marks relative to both sides of a system (Figure 13):

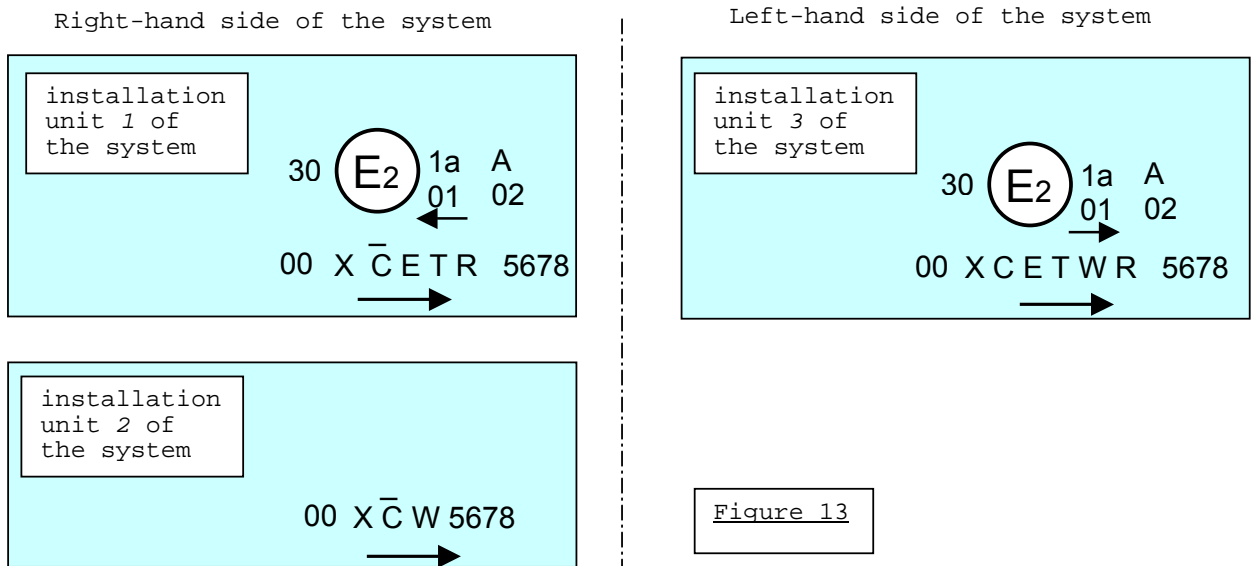

This example corresponds to an adaptive front-lighting system comprised of two installation units for the right side of the vehicle and one installation unit for the left side.

The system bearing the above approval marks meets the requirements of this Regulation (00 series of amendments) in respect of both a passing beam for left-hand traffic and a driving beam with a maximum intensity comprised between 86 250 and 101 250 candelas (as indicated by the number 30) grouped with a front direction indicator lamp of category 1a, approved in accordance with the 01 series of amendments of Regulation No. 6 and a front position lamp approved in accordance with the 02 series of amendments of Regulation No. 7.

The installation unit 1 of the system (right side) is designed to contribute to the class C ~~(basic)~~ passing beam and the class E passing beam. The score above "C" indicates that on that side more than one installation unit contributes to the class C ~~(basic)~~ passing beam. The letter "T" to the right following the listed symbols indicates that each, the class C ~~(basic)~~ passing beam and the class E passing beam are providing a bending mode.

The installation unit 2 of the system (right side of the vehicle) is designed to provide the second part of the class C ~~(basic)~~ passing beam of that side (as indicated by the score above "C") and a class W passing beam.

The installation unit 3 of the system (left side) is designed to contribute to the class C ~~(basic)~~ passing beam, a class E passing beam, both with bending mode and a class W passing beam.

All these three installation units shall bear the same approval number.

Annex 3

PASSING BEAM PHOTOMETRIC REQUIREMENTS*)

*) Note: measurement procedure prescribed in annex 10 to this Regulation.

For the purpose of this annex:

"above it" means vertically above, only; "below it" means vertically below, only.

Angular positions are expressed in deg up (U) or down (D) from H-H respectively right (R) or left (L) from V-V.

Figure 1: Angular positions of passing beam photometric requirements (indicated for right-hand traffic)

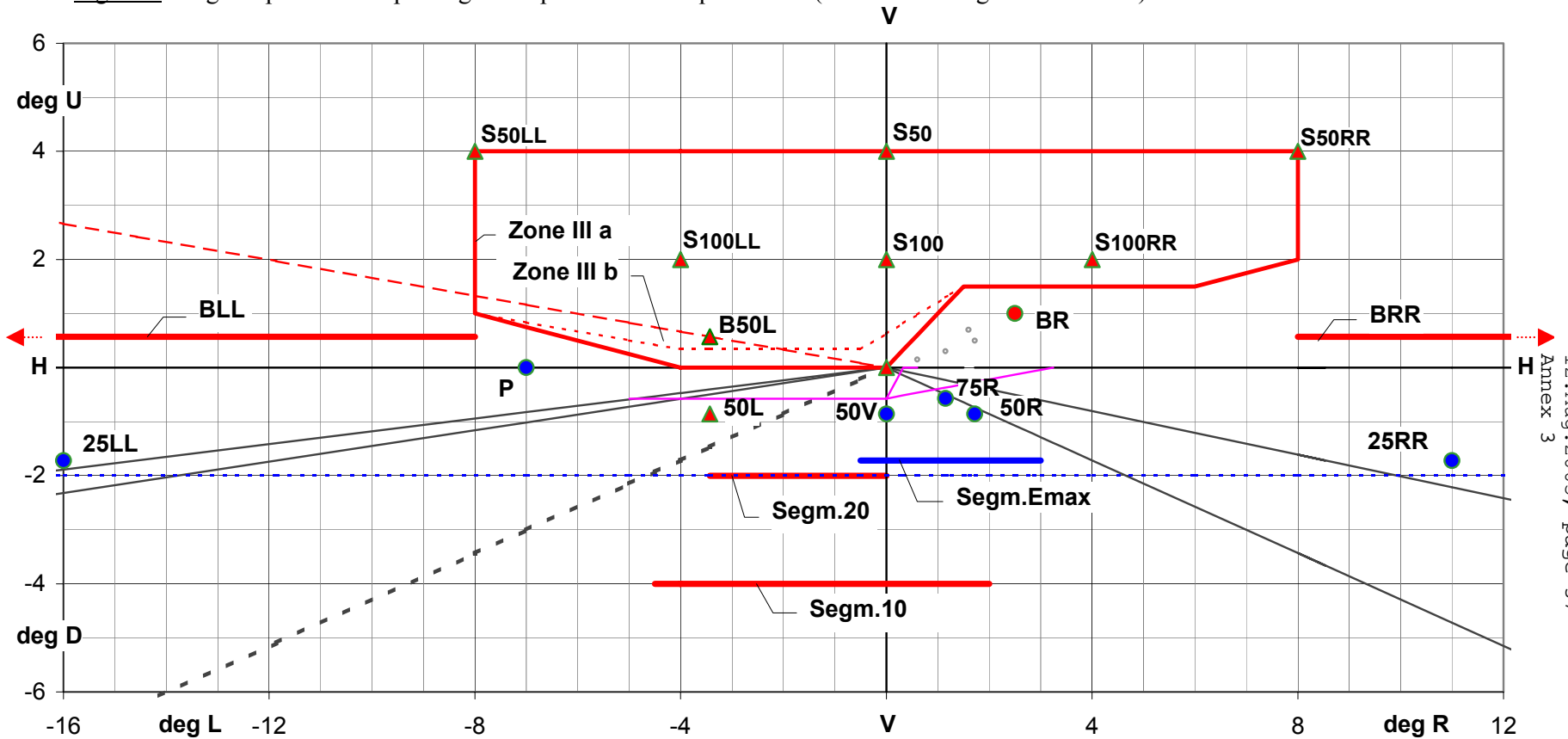

Table 1: Passing beam photometric requirements

tabled requirements expressed in lux @ 25m			Position /deg			class C (basic) passing beam		class V passing beam		class E passing beam		class W passing beam			
			horizontal		vertical	min	max	min	max	min	max	min	max		
No	Element		at/ from	to	at										
Part A	1	B50L 4/	L 3.43		U 0.57		0.4		0.4		0.7		0.7		
	2	HV 4/	V		H		0.7		0.7						
	3	BR 4/	R 2.5		U 1	0.2	2	0.1	1	0.2	2	0.2	3		
	4	Segment BRR 4/	R 8	R 20	U 0.57		4		1		4		6		
	5	Segment BLL 4/	L 8	L 20	U 0.57		0.7		1		1		1		
	6	P	L 7		H	0.1						0.1			
	7	Zone III (as specified by Table 3 of this annex)					0.7		0.7		1		1		
	8a	S 50, S 50LL, S 50RR 5/			U 4	0.1	7/			0.1	7/	0.1	7/		
	9a	S 100, S 100LL, S 100RR 5/			U 2	0.2	7/			0.2	7/	0.2	7/		
	10	50 R	R 1.72		D 0.86				6						
	11	75 R	R 1.15		D 0.57	12				18		24			
	12	50 V	V		D 0.86	6			6		12		12		
	13	50 L	L 3.43		D 0.86	4.2	25[20/15]		4.2	25[20/15]	8		8	[35/20]	
	14	25 LL	L 16		D 1.72	1.4			1		1.4		4		
	15	25 RR	R 11		D 1.72	1.4			1		1.4		4		
	16	Segment 20 and below it	L 3.5	V	D 2								20	2/	
	17	Segment 10 and below it	L 4.5	R 2.0	D 4		44-10	1/		44-10	1/	44-10	1/	8	2/
	18	E _{max} 3/					20	50	10	50	20	90	35	80	2/

Part B (bending modes): Table 1 Part A applies, however with the lines No.1, 2, 7, 13 and 18 being replaced by those listed hereunder

Part B	1	B50L 4/	L 3.43		U 0.57		0.6		0.6				0.9	
	2	HV 4/					1		1					
	7	Zone III (as specified by Table 3 of this annex)					1		1		1		1	
	13	50L	L 3.43		D 0.86	2		2		4		4		
	18	E _{max} 6/					12	50	6	50	12	90	24	80

1/ max 14 lx, if the system is designed to provide also a class W passing beam

3/ Position requirements according to the provisions of Table 2 below ("Segment E_{max}")

5/ Position requirements according to the provisions of Table 5 below

7/ One pair of position lamps, being incorporated with the system or being intended to be installed together with the system may be activated according to the indications of the Applicant

2/ requirements according to the provisions indicated in Table 4 below apply in addition the contribution of each side of the system, when measured according to the provisions of Annex 10 to this Regulation shall not be less than 0,1 lx

4/ Annex 10 to this Regulation shall not be less than 0,1 lx

6/ Position requirements as indicated in paragraph 6.2.6.2. of this Regulation

Table 2: Passing beam elements **angular** position/extend, additional requirements

No	angular position / extend in deg beam part designation and requirement	Class C passing beam		Class V passing beam		Class E passing beam		Class W passing beam	
		horizontal	vertical	horizontal	vertical	horizontal	vertical	horizontal	vertical
2.1.	E_{max} shall not be positioned outside of the rectangle extending (above " Segment A1 ")	0.5L to 3R	0.3D to 1.72D		0.3D to 1.72D	0.5L to 3R	0.1D to 1.72D	0.5L to 3R	0.3D to 1.72D
2.2.	the " cut-off " and part(s) of shall: - comply with the requirements of paragraph 1. of Annex 9 to this Regulation and be positioned with its " kink " at V-V and - be positioned with its " flat horizontal part "								
			at V = 0.57 D		not above 0.57D not below 1.3D		not above 0.23D not below 0.57D		not above 0.23D not below 0.57D

Table 3: Passing beam zones III, defining corner points

Angular Position in Deg	Corner Point No.	1	2	3	4	5	6	7	8
Zone III a for class C or class V Passing Beam	horizontal	8 L	8 L	8 R	8 R	6 R	1.5 R	V-V	4 L
	vertical	1 U	4 U	4 U	2 U	1.5 U	1.5 U	V-V	V-V
Zone III b for class W or class E Passing Beam	horizontal	8 L	8 L	8 R	8 R	6 R	1.5 R	0.5 L	4 L
	vertical	1 U	4 U	4 U	2 U	1.5 U	1.5 U	0.34 U	0.34 U

Table 4: Additional provisions for class W passing beam, expressed in lx@25m

4.1.	Definition and Requirements for Segments E , F1 , F2 , and F3 (not shown in Fig.1 above) Not more than 0.2 lx are allowed: a) on a segment E extending at U 10 deg from L 20 to R 20 deg and b) on three vertical segments F1 , F2 and F3 at horizontal positions L10 deg , V and R 10 deg , each extending from U 10 to U 60 deg .
4.2.	Alternative/ Additional Set of Requirements for E_{max} , segment 20 and segment 10 : Table 1 Part A or B applies, however with the max requirements in lines No. 16, 17 and 18 being replaced by those indicated hereunder If, according to the Applicants specification according to paragraph 2.2.2. of this Regulation a class W passing beam is designed to produce on segment 20 and below it not more than 10 lx and on segment 10 and below it not more than 4 lx , the design value for E_{max} of that beam shall not exceed 100 lx

Table 5: Overhead sign requirements, angular position of measurement points

Point Designation	S50LL	S50	S50RR	S100LL	S100	S100RR
Angular Position in Deg	4 U / 8 L	4 U / V-V	4 U / 8 R	2 U / 4 L	2 U / V-V	2 U / 4 R

For information only: Passing beam photometric values of Table 1, expressed in candelas

tabled requirements expressed in lux @ 25m		Position /deg			class C (basic) passing beam		class V passing beam		class E passing beam		class W passing beam					
		horizontal	vertical		min	max	min	max	min	max	min	max				
No	Element	at/ from	to	at												
Part A	1	<i>not actualized</i>					250		250		438		438			
	2								438		438					
	3							125	1,250		63	625	125	1,250	125	1,875
	4								2,500			625		2,500		3,750
	5								438			625		625		625
	6								63							63
	7								438			438		625		625
	8	S	V		U 4	63			63		63		63			
	9	SL	L 8		U 4	31					31		31			
	10	SR	R 8		U 4	31					31		31			
	11	50 R	R 1.72		D 0.86				3,750							
	12	75 R	R 1.15		D 0.57	7,500					11,250		15,000			
	13	50 V	V		D 0.86	3,750			3,750		7,500		7,500			
	14	50L	L 3.43		D 0.86	2,625	15,625		2,625	15,625	5,000		5,000	21,875		
	15	25LL	L 16		D 1.72	875			625		875		2,500			
	16	25RR	R 11		D 1.72	875			625		875		2,500			
	17	Segment C and below it	L 3.5	V	D 2								12,500 <u>2/</u>			
	18	Segment D (10m-Line) and below it	L 1.5	R 2.0	D 4		8,750 <u>1/</u>		8,750 <u>1/</u>		8,750 <u>1/</u>		5,000 <u>2/</u>			
	19	E _{max} <u>3/</u>				12,500	31,250		6,250	31,250	12,500	56,250	21,875	50,000 <u>2/</u>		

1/ max 11,250 cd, if the system is designed to provide also a class W passing beam

2/ requirements according to the provisions indicated in Table 4 below apply in addition

3/ Position requirements according to the provisions of Table 2 below

the contribution of each side of the system, when measured according to the provisions of 4/ Annex 10 to this Regulation shall not be less than 63 cd

Part B (bending modes): Table 1 Part A applies, however with the lines No.1, 2, 7, 14 and 19 being replaced by those listed hereunder

Part B	1	B50L <u>4/</u>	L 3.43		U 0.57			375		375			563
	2	HV <u>4/</u>						625		625			
	7	Zone III (as specified by Table 3 of this annex)						625		625		625	625
	14	50L	L 3.43		D 0.86	1,250		1,250		2,500		2,500	
	19	E _{max} <u>5/</u>				7,500	31,250		3,750	31,250	7,500	56,250	15,000

5/ Position requirements as indicated in paragraph 6.2.6.2. of this Regulation

Annex 4
TESTS FOR STABILITY OF PHOTOMETRIC PERFORMANCE OF SYSTEMS IN
OPERATION

TESTS ON COMPLETE SYSTEMS

Once the photometric values have been measured according to the prescriptions of this Regulation, in the point of Emax for driving beam and in points HV, 50 V and B 50 L (or R), whichever applies for passing beam a complete system sample shall be tested for stability of photometric performance in operation.

For the purpose of this annex:

- (a) *"complete system" shall be understood to mean the complete right and left side of a system itself including electronic light source control-gear(s) and/or supply and operating device(s) and those surrounding body parts and lamps which could influence its thermal dissipation. Each installation unit of the system and lamp(s), if any, of the complete system may be tested separately;*
- (b) *"test sample" in the following text means correspondingly either the "complete system" or the installation unit under test;*
- (c) *the expression "light source" shall be understood to comprise also any single filament of a filament lamp.*

The tests shall be carried out:

- (i) *in a dry and still atmosphere at an ambient temperature of $23\text{ }^{\circ}\text{C} \pm 5\text{ }^{\circ}\text{C}$, the test sample being mounted on a base representing the correct installation on the vehicle;*
- (ii) *in case of replaceable light sources: using a mass production filament light source, which has been aged for at least one hour, or a mass production gas-discharge light source, which has been aged for at least 15 hours.*

The measuring equipment shall be equivalent to that used during system approval tests.

The system or part(s) of shall, prior to the subsequent tests, be set to the neutral state.

1. TEST FOR STABILITY OF PHOTOMETRIC PERFORMANCE

1.1. Clean test sample

Each test sample shall be operated for 12 hours as described in paragraph 1.1.1. and checked as prescribed in paragraph 1.1.2.

1.1.1. Test procedure

1.1.1.1. Test sequence

- (a) in the case where a test sample is designed to provide only one lighting function (driving beam or passing beam) and not more than one class in case of passing

beam, the corresponding light source(s) is/are lit for the time 1/ specified in paragraph 1.1. above;

- (b) in the case where a test sample provides more than one function or class of passing beam according to this Regulation: if the applicant declares that each specified function or class of passing beam of the test sample has its own light source(s), being exclusively lit 2/ at a time, the test shall be carried out in accordance with this condition, activating 1/ the most power consuming mode of each specified function or class of passing beam successively for the same (equally divided) part of the time specified in paragraph 1.1.

In all other cases, 1/ 2/ the test sample shall be subjected to the following cycle test for each, the mode(s) of class C (~~basic~~) passing beam, the class V passing beam, the class E passing beam and the class W passing beam, whatever is provided or partly provided by the test sample, for the same (equally divided) part of the time specified in paragraph 1.1.:

15 minutes, first, e.g. class C (~~basic~~) passing beam mode lit with its most power consuming mode for straight road conditions;

5 minutes, same passing beam mode lit as before and, additionally, all light sources 3/ of the test sample, which are possible to be lit at the same time, according to the Applicants declaration;

after having reached the said (equally divided) part of the time specified in paragraph 1.1., the above cycle test shall be performed with the second, third and fourth class of passing beam, if applicable, in the above order.

- (c) In the case where a test sample includes other grouped lighting function(s), all the individual functions shall be lit simultaneously for the time specified in (a) or (b) above for individual lighting functions, according to the manufacturer's specifications.
- (d) In the case of a test sample designed to provide a passing beam bending mode with an additional light source being energized, said light source shall simultaneously be switched on for 1 minute, and switched off for 9 minutes during the activation of the passing beam only, specified in (a) or (b) above.

1.1.1.2. Test voltage

- (a) In case of replaceable filament light source(s) operated directly under vehicle voltage system conditions:

-
- 1/ When the "test sample" is grouped and/or reciprocally incorporated with signalling lamps, the latter shall be lit for the duration of the test. In the case of a direction indicator lamp, it shall be lit in flashing operation mode with an on/off time ratio of approximately one to one.
- 2/ Should additional light sources be simultaneously lit when headlamp flashing is used, this shall not be considered as being normal use of the light sources simultaneously.
- 3/ All light sources of lighting functions even if no approval is sought according to this Regulation must be taken into account, except those covered by footnote 2/.

The voltage shall be adjusted so as to supply 90 per cent of the maximum wattage specified in Regulation No. 37 for the filament light source(s) used. The applied wattage shall in all cases comply with the corresponding value of a filament light source of 12 V rated voltage, except if the applicant specifies that the test sample may be used at a different voltage. In this case, the test shall be carried out with the filament light source whose wattage is the highest that can be used.

- (b) In case of replaceable gas discharge light source(s): The test voltage for the electronic light source control-gear is 13.5 ± 0.1 volts for 12 V vehicle voltage system, or otherwise specified in the application for approval.
- (c) In the case of non-replaceable light source operated directly under vehicle voltage system conditions: All measurements on lighting units equipped with non-replaceable light sources (filament light sources and/or others) shall be made at 6.75 V, 13.5 V or 28.0 V or at other voltages according to the vehicle voltage system as specified by the Applicant respectively.
- (d) In the case of light sources, replaceable or non-replaceable, being operated independently from vehicle supply voltage and fully controlled by the system, or, in the case of light sources supplied by a supply and operating device, the test voltages as specified above shall be applied to the input terminals of that device. The test laboratory may require from the manufacturer the supply and operating device or a special power supply needed to supply the light source(s).

1.1.2. Test results

1.1.2.1. Visual inspection:

Once the test sample has been stabilized to the ambient temperature, the test sample lens and the external lens, if any, shall be cleaned with a clean, damp cotton cloth. It shall then be inspected visually; no distortion, deformation, cracking or change in colour of either the test sample lens or the external lens, if any, shall be noticeable.

1.1.2.2. Photometric test:

To comply with the requirements of this Regulation, the photometric values shall be verified in the following points:

Class C (~~basic~~) passing beam, and each specified other passing beam class: 50 V, B 50 L (or R), and HV, if applicable.

Driving beam, under neutral state conditions: point of Emax.

Another aiming may be carried out to allow for any deformation of the test sample base due to heat (the change of the position of the cut-off line is covered in paragraph 2. of this annex).

A 10 per cent discrepancy between the photometric characteristics and the values measured prior to the test is permissible including the tolerances of the photometric procedure.

1.2. Dirty test sample

After being tested as specified in paragraph 1.1. above, the test sample shall be operated for one hour as described in paragraph 1.1.1. for each function or class of 4/, after being prepared as prescribed in paragraph 1.2.1., and checked as prescribed in paragraph 1.1.2.; after each test a sufficient cooling down period must be assured.

1.2.1. Preparation of the test sample

1.2.1. Test mixture

1.2.1.1. For a *system* or parts thereof with the outside lens in glass: A mixture of water and polluting agent to be applied to the *test sample* shall be composed of: 9 parts by weight of silica sand with a particle size of 0-100 µm corresponding to distribution prescribed in paragraph 2.1.3., 1 part by weight of vegetable carbon dust (beechwood) with a particle size of 0-100 µm, 0.2 parts by weight of NaCMC 5/, and an appropriate quantity of distilled water with a conductivity of less than 1 mS/m.

1.2.1.2. For a *system* or parts thereof with the outside lens in plastic material:

The mixture of water and polluting agent to be applied to the *test sample* shall be composed of: 9 parts by weight of silica sand with a particle size of 0-100 µm corresponding to distribution prescribed in paragraph 2.1.3., 1 part by weight of vegetable carbon dust (beechwood) with a particle size of 0-100 µm, 0.2 parts by weight of NaCMC 5/, 5 parts by weight of sodium chloride (pure at 99 per cent), 13 parts by weight of distilled water with a conductivity of less than 1 mS/m, and 2 ± 1 parts by weight of surface-actant.

1.2.1.3. Particle-size distribution

Particle size (in µm)	Particle-size distribution in (%)
0 to 5	12 ± 2
5 to 10	12 ± 3
10 to 20	14 ± 3
20 to 40	23 ± 3
40 to 80	30 ± 3
80 to 100	9 ± 3

1.2.1.4. The mixture must not be more than 14 days old.

1.2.1.5. Application of the test mixture to the *test sample*:

The test mixture shall be uniformly applied to the entire light- emitting surface(s) of the *test sample* and then left to dry. This procedure shall be repeated until the illuminating

4/ The class W passing beam, if any, is disregarded for lighting units providing or contributing to any other passing beam class or lighting function.

5/ NaCMC represents the sodium salt of carboxymethylcellulose, customarily referred to as CMC. The NaCMC used in the dirt mixture shall have a degree of substitution (DS) of 0.6-0.7 and a viscosity of 200-300 cP for a 2 per cent solution at 20°C.

value has dropped to 15-20 per cent of the values measured for each following point under the conditions described in this annex:

point Emax in *driving beam, under neutral state conditions,*

50 V for a class C (~~basic~~) *passing beam, and each specified passing beam mode.*

2. TEST FOR CHANGE IN VERTICAL POSITION OF THE "CUT-OFF" LINE UNDER THE INFLUENCE OF HEAT.

This test consists of verifying that the vertical drift of the cut-off line under the influence of heat does not exceed a specified value for a system or part(s) of emitting a class C (basic) passing beam, or each specified passing beam mode.

If the test sample consists of more than one lighting unit or more than one assembly of lighting units which provide a cut-off, each of these is understood to be a test sample for the purpose of this test and must be tested separately.

The *test sample* tested in accordance with paragraph 1. shall be subjected to the test described in paragraph 2.1., without being removed from or readjusted in relation to its test fixture.

If the *test sample* has a moving optical part, only the position closest to the average vertical angular *stroke and/or the initial position according to the neutral state* is chosen for this test.

The test is confined to signal input conditions corresponding to a straight road, only.

2.1. Test

For the purpose of this test, the voltage shall be adjusted as specified in paragraph 1.1.1.2.;

The test sample shall be operated and tested on class C (~~basic~~) passing beam, class V passing beam, class E passing beam and class W passing beam, whatever applies.

The position of the cut-off line in its horizontal part between VV and the vertical line passing through point B 50 L (or R) shall be verified 3 minutes (r3) and 60 minutes (r60) respectively after operation.

The measurement of the variation in the cut-off line position as described above shall be carried out by any method giving acceptable accuracy and reproducible results.

Test results

2.2.1. The result *expressed* in milliradians (mrad) shall be considered as acceptable for a *passing beam test sample*, when the absolute value $\Delta r_1 = | r_3 - r_{60} |$ recorded on the *test sample* is not more than 1.0 mrad ($\Delta r_1 \leq 1.0$ mrad).

2.2.2. However, if this value is more than 1.0 mrad but not more than 1.5 mrad ($1.0 \text{ mrad} < \Delta r_1 \leq 1.5 \text{ mrad}$), a second *test sample* shall be tested as described in paragraph 2.1. after being subjected three consecutive times to the cycle as described

below, in order to stabilize the position of mechanical parts of the *test sample* on a base representative of the correct installation on the vehicle:

Operation of the passing beam for one hour, (the voltage shall be adjusted as specified in paragraph 1.1.1.2.),

period of rest for one hour.

The *system or part thereof* shall be considered as acceptable if the mean value of the absolute values Δr_I measured on the first *test sample* and Δr_{II} measured on the second *test sample* is not more than 1.0 mrad.

$$\left(\frac{\Delta r_I + \Delta r_{II}}{2} \leq 1,0 \text{ mrad} \right)$$

Annex 5

MINIMUM REQUIREMENTS FOR CONFORMITY OF PRODUCTION CONTROL PROCEDURES

1. GENERAL
 - 1.1. The conformity requirements shall be considered satisfied from a mechanical and a geometrical standpoint, if the differences do not exceed inevitable manufacturing deviations within the requirements of this Regulation. This condition also applies to colour.
 - 1.2. With respect to photometric performances, the conformity of mass-produced *systems* shall not be contested if, when testing photometric performances of any *system* chosen at random and *equipped with a light source energized, and if applicable corrected, as prescribed in paragraphs 1. and 2. of annex 10 to this Regulation:*
 - 1.2.1. no value *measured and corrected according to the prescriptions of paragraph 2 of annex 10 to this Regulation* deviates unfavourably by more than 20 per cent from the value prescribed in this Regulation;
 - 1.2.1.1. For the following values of the passing beam and its modes, the maximum unfavourable deviation may be respectively:
 - maximum values at point B50L 0.2 lx equivalent 20 per cent and 0.3 lx equivalent 30 per cent;
 - maximum values at zone III, HV and segment BLL: 0.3 lx equivalent 20 per cent and 0.45 lx equivalent 30 per cent;
 - maximum values at segments E, F1, F2 and F3: 0.2 lx equivalent 20 per cent and 0.3 lx equivalent 30 per cent;
 - minimum values at BR, P, S 50, S 50LL, S 50RR, S 100, S 100LL, S 100RR, and those required by footnote 4/ of table 1 in annex 3 of this Regulation (B50L, HV, BR, BRR, BLL): half of the required value equivalent 20 per cent and three quarter of the required value equivalent 30 per cent;
 - 1.2.1.2. for the driving beam, HV being situated within the isolux 0.75 E_{max}, a tolerance of +20 per cent for maximum values and -20 per cent for minimum values is observed for the photometric values at any measuring point specified in paragraph 6.3.2. of this Regulation.
 - 1.2.2. If the results of the test described above do not meet the requirements, the alignment of the *system* may be changed, provided that the axis of the beam is not displaced laterally by more than 0.5 deg to the right or left and not by more than 0.2 deg up and down, each independently and with respect to the first aiming.
These provisions do not apply to lighting units as indicated under paragraph 6.3.1.1. of this Regulation.
 - 1.2.3. If the results of the tests described above do not meet the requirements, tests shall be repeated using another standard (étalon) light source and/or another supply and operating device.

- 1.3. With respect to the verification of the change in vertical position of the "cut-off" line for passing beam under the influence of heat, the following procedure shall be applied:

One of the sampled *systems* shall be tested according to the procedure described in paragraph 2.1. of annex 4 after being subjected three consecutive times to the cycle described in paragraph 2.2.2. of annex 4.

The *system* shall be considered as acceptable if Δr does not exceed 1.5 mrad.

If this value exceeds 1.5 mrad but is not more than 2.0 mrad, a second sample shall be subjected to the test after which the mean of the absolute values recorded on both samples shall not exceed 1.5 mrad.

- 1.4. The chromaticity co-ordinates as defined in paragraph 7. of this Regulation shall be conformed to.

2. MINIMUM REQUIREMENTS FOR VERIFICATION OF CONFORMITY BY THE MANUFACTURER

For each type of *system* the holder of the approval mark shall carry out at least the following tests, at appropriate intervals. The tests shall be carried out in accordance with the provision of this Regulation.

If any sampling shows non-conformity with regard to the type of test concerned, further samples shall be taken and tested. The manufacturer shall take steps to ensure the conformity of the production concerned.

2.1. Nature of tests

Tests of conformity in this Regulation shall cover the photometric characteristics and the verification of the change in vertical position of the cut-off line for passing beam under the influence of heat.

2.2. Methods used in tests

- 2.2.1. Tests shall generally be carried out in accordance with the methods set out in this Regulation.

- 2.2.2. In any test of conformity carried out by the manufacturer, equivalent methods may be used with the consent of the competent authority responsible for approval tests. The manufacturer is responsible for proving that the applied methods are equivalent to those laid down in this Regulation.

- 2.2.3. The application of paragraphs 2.2.1. and 2.2.2. requires regular calibration of test apparatus and its correlation with measurement made by a competent authority.

- 2.2.4. In all cases the reference methods shall be those of this Regulation, particular for the purpose of administrative verification and sampling.

2.3. Nature of sampling

Samples of *systems* shall be selected at random from the production of a uniform batch. A uniform batch means a set of *systems* of the same type, defined according to the production methods of the manufacturer.

The assessment shall, in general, cover series production from individual factories. However, a manufacturer may group together records concerning the same type from several factories provided these operate under the same quality system and quality management.

2.4. Measured and recorded photometric characteristics

The sampled headlamps shall be subjected to photometric measurements at the points provided for in the Regulation, the reading being limited:
to points Emax, HV 1/, "HL" and "HR" 2/ in the case of a driving beam,
to points B50L, HV *if applicable*, 50V, 75R *if applicable*, and 25LL in the case of the passing beam(s) (see Figure 1 in annex 3).

2.5. Criteria governing acceptability

The manufacturer is responsible for carrying out a statistical study of the test results and for defining, in agreement with the competent authority, criteria governing acceptability of his products in order to meet the specification laid down for verification of conformity of products in paragraph 9.1. of this Regulation.

The criteria governing acceptability shall be such that, with a confidence level of 95 per cent, the minimum probability of passing a spot check in accordance with annex 7 (first sampling) would be 0.95.

1/ When the driving beam is reciprocally incorporated with the passing beam, HV in the case of the driving beam shall be the same measuring point as in the case of the passing beam.

2/ "HL" and "HR": points on "H-H" located at 2.6 deg to the left and to the right of point HV respectively.

Annex 6

REQUIREMENTS FOR SYSTEMS INCORPORATING LENSES OF PLASTIC MATERIAL – TESTING OF LENS OR MATERIAL SAMPLES AND COMPLETE SYSTEMS OR PART(S) OF SYSTEMS

1. GENERAL SPECIFICATIONS

- 1.1. The samples supplied pursuant to paragraph 2.2.4. of this Regulation shall satisfy the specifications indicated in paragraphs 2.1. to 2.5. below.
- 1.2. The two samples of complete *systems or part thereof* supplied pursuant to paragraph 2.2.3. of this Regulation and incorporating lenses of plastic material shall, with regard to the lens material, satisfy the specifications indicated in paragraph 2.6. below.
- 1.3. The samples of lenses of plastic material or samples of material shall be subjected, with the reflector to which they are intended to be fitted (where applicable), to approval tests in the chronological order indicated in Table A reproduced in Appendix 1 to this annex.
- 1.4. However, if the *system* manufacturer can prove that the product has already passed the tests prescribed in paragraphs 2.1. to 2.5. below, or the equivalent tests pursuant to another Regulation, those tests need not be repeated; only the tests prescribed in Appendix 1, Table B, shall be mandatory.
- 1.5. If the *system or part thereof* is designed for right-hand installation only, or for left-hand installation only, tests pursuant to this annex may be done on one sample only, at the choice of the applicant.

2. TESTS

2.1. Resistance to temperature changes

2.1.1. Tests

Three new samples (lenses) shall be subjected to five cycles of temperature and humidity (RH = relative humidity) change in accordance with the following programme:

3 hours at $40^{\circ}\text{C} \pm 2^{\circ}\text{C}$ and 85-95 per cent RH;
1 hour at $23^{\circ}\text{C} \pm 5^{\circ}\text{C}$ and 60-75 per cent RH;
15 hours at $-30^{\circ}\text{C} \pm 2^{\circ}\text{C}$;
1 hour at $23^{\circ}\text{C} \pm 5^{\circ}\text{C}$ and 60-75 per cent RH;
3 hours at $80^{\circ}\text{C} \pm 2^{\circ}\text{C}$;
1 hour at $23^{\circ}\text{C} \pm 5^{\circ}\text{C}$ and 60-75 per cent RH;

Before this test, the samples shall be kept at $23^{\circ}\text{C} \pm 5^{\circ}\text{C}$ and 60-75 per cent RH for at least four hours.

Note: The periods of one hour at $23^{\circ}\text{C} \pm 5^{\circ}\text{C}$ shall include the periods of transition from one temperature to another which are needed in order to avoid thermal shock effects.

2.1.2. Photometric measurements

2.1.2.1. Method

Photometric measurements shall be carried out on the samples before and after the test.

These measurements shall be made *according to annex 10 to this Regulation*, at the following points:

B 50 L and 50 V for the *class C (~~basic~~) passing beam lighting of a system* intended for right-hand traffic (B 50 R and 50 V in the case of *systems* intended for left-hand traffic);

E_{\max} for the *driving beam* of a *system*.

2.1.2.2. Results

The variation between the photometric values measured on each sample before and after the test shall not exceed 10 per cent including the tolerances of the photometric procedure.

2.2. Resistance to atmospheric and chemical agents

2.2.1. Resistance to atmospheric agents

Three new samples (lenses or samples of material) shall be exposed to radiation from a source having a spectral energy distribution similar to that of a black body at a temperature between 5 500 K and 6000 K. Appropriate filters shall be placed between the source and the samples so as to reduce as far as possible radiation with wave lengths smaller than 295 nm and greater than 2500 nm. The samples shall be exposed to an energetic illumination of $1200 \text{ W/m}^2 \pm 200 \text{ W/m}^2$ for a period such that the luminous energy that they receive is equal to $4500 \text{ MJ/m}^2 \pm 200 \text{ MJ/m}^2$. Within the enclosure, the temperature measured on the black panel placed on a level with the samples shall be $50^\circ\text{C} \pm 5^\circ\text{C}$. In order to ensure a regular exposure, the samples shall revolve around the source of radiation at a speed between 1 and 5 1/min.

The samples shall be sprayed with distilled water of conductivity lower than 1 mS/m at a temperature of $23^\circ\text{C} \pm 5^\circ\text{C}$, in accordance with the following cycle:

spraying: 5 minutes; drying: 25 minutes.

2.2.2. Resistance to chemical agents

After the test described in paragraph 2.2.1. above and the measurement described in paragraph 2.2.3.1. below have been carried out, the outer face of the said three samples shall be treated as described in paragraph 2.2.2.2. with the mixture defined in paragraph 2.2.2.1. below.

2.2.2.1. Test mixture

The test mixture shall be composed of 61.5 per cent n-heptane, 12.5 per cent toluene, 7.5 per cent ethyl tetrachloride, 12.5 per cent trichloroethylene and 6 per cent xylene (volume per cent).

2.2.2.2. Application of the test mixture

Soak a piece of cotton cloth (as per ISO 105) until saturation with the mixture defined in paragraph 2.2.2.1. above and, within 10 seconds, apply it for 10 minutes to the outer face of the sample at a pressure of 50 N/cm², corresponding to an effort of 100 N applied on a test surface of 14 x 14 mm.

During this 10-minute period, the cloth pad shall be soaked again with the mixture so that the composition of the liquid applied is continuously identical with that of the test mixture prescribed.

During the period of application, it is permissible to compensate the pressure applied to the sample in order to prevent it from causing cracks.

2.2.2.3. Cleaning

At the end of the application of the test mixture, the samples shall be dried in the open air and then washed with the solution described in paragraph 2.3. (Resistance to detergents) at 23°C±5°C. Afterwards the samples shall be carefully rinsed with distilled water containing not more than 0.2 per cent impurities at 23°C±5°C and then wiped off with a soft cloth.

2.2.3. Results

2.2.3.1. After the test of resistance to atmospheric agents, the outer face of the samples shall be free from cracks, scratches, chipping and deformation, and the mean variation in transmission $\Delta t = (T_2 - T_3)/T_2$ measured on the three samples according to the procedure described in Appendix 2 to this annex shall not exceed 0.020 (~~$\Delta t_{\text{m}} \leq 0.020$~~).

2.2.3.2. After the test of resistance to chemical agents, the samples shall not bear any traces of chemical staining likely to cause a variation of flux diffusion, whose mean variation $\Delta d = (T_5 - T_4)/T_2$ measured on the three samples according to the procedure described in Appendix 2 to this annex shall not exceed 0.020 (~~$\Delta d_{\text{m}} \leq 0.020$~~).

2.2.4. Resistance to light source radiation

If necessary the following test shall be done:

Flat samples of each light transmitting plastic component of the system are exposed to the light of the light source. The parameters such as angles and distances of those samples shall be the same as in the system. These samples shall have the same colour and surface treatment, if any, as the parts of the system.

After 1 500 hours of continuous exposure, the colorimetric specification of the transmitted light must be met with a new light source, and the surface of the samples shall be free of cracks, scratches, scalings or deformation.

The UV-resistance testing of internal materials to light source radiation is not necessary if light sources according to Regulation No. 37 and/or low-UV-type gas discharge light sources are being applied or if provisions are taken, to shield the relevant system components from UV radiation, e.g. by glass filters.

2.3. Resistance to detergents and hydrocarbons

2.3.1. Resistance to detergents

The outer face of three samples (lenses or samples of material) shall be heated to $50^{\circ}\text{C} \pm 5^{\circ}\text{C}$ and then immersed for five minutes in a mixture maintained at $23^{\circ}\text{C} \pm 5^{\circ}\text{C}$ and composed of 99 parts distilled water containing not more than 0.02 per cent impurities and one part alkylaryl sulphonate.

At the end of the test, the samples shall be dried at $50^{\circ}\text{C} \pm 5^{\circ}\text{C}$. The surface of the samples shall be cleaned with a moist cloth.

2.3.2. Resistance to hydrocarbons

The outer face of these three samples shall then be lightly rubbed for one minute with a cotton cloth soaked in a mixture composed of 70 per cent n-heptane and 30 per cent toluene (volume per cent), and shall then be dried in the open air.

2.3.3. Results

After the above two tests have been performed successively, the mean value of the variation in transmission $\Delta t = (T_2 - T_3) / T_2$ measured on the three samples according to the procedure described in Appendix 2 to this annex shall not exceed 0.010 ($\Delta t_m \leq 0.010$).

2.4. Resistance to mechanical deterioration

2.4.1. Mechanical deterioration method

The outer face of the three new samples (lenses) shall be subjected to the uniform mechanical deterioration test by the method described in Appendix 3 to this annex.

2.4.2. Results

After this test, the variations:

in transmission: $\Delta t = (T_2 - T_3) / T_2$
and in diffusion: $\Delta d = (T_5 - T_4) / T_2$

shall be measured according to the procedure described in Appendix 2 in the area specified in paragraph 2.2.4.1.1. of this Regulation. The mean value of the three samples shall be such that:

$\Delta t_m \leq 0.100$; $\Delta d_m \leq 0.050$.

2.5. Test of adherence of coatings, if any

2.5.1. Preparation of the sample

A surface of 20mm x 20mm in area of the coating of a lens shall be cut with a razor blade or a needle into a grid of squares approximately 2mm x 2mm. The pressure on the blade or needle shall be sufficient to cut at least the coating.

2.5.2. Description of the test

Use an adhesive tape with a force adhesion of 2 N/(cm of width) \pm 20 per cent measured under the standardized conditions specified in Appendix 4 to this annex. This adhesive tape, which shall be at least 25 mm wide, shall be pressed for at least five minutes to the surface prepared as prescribed in paragraph 2.5.1.

Then the end of the adhesive tape shall be loaded in such a way that the force of adhesion to the surface considered is balanced by a force perpendicular to that surface. At this stage, the tape shall be torn off at a constant speed of 1.5 m/s \pm 0.2 m/s.

2.5.3. Results

There shall be no appreciable impairment of the grided area. Impairments at the intersections between squares or at the edges of the cuts shall be permitted, provided that the impaired area does not exceed 15 per cent of the grided surface.

2.6. Tests of the complete *system* incorporating a lens of plastic material

2.6.1. Resistance to mechanical deterioration of the lens surface

2.6.1.1. Tests

The lens of *system* sample No. 1 shall be subjected to the test described in paragraph 2.4.1. above.

2.6.1.2. Results

After the test, the results of photometric measurements carried out on the *system or part thereof* in accordance with this Regulation shall not exceed by more than 30 per cent the maximum values prescribed at points B50L and HV and not be more than 10 per cent below the minimum values prescribed at point 75R (in the case of *systems* intended for left-hand traffic, the points to be considered are B50R, HV and 75L), *if applicable*.

2.6.2. Test of adherence of coatings, if any

The lens of *installation unit* sample No. 2 shall be subjected to the test described in paragraph 2.5. above.

3. VERIFICATION OF THE CONFORMITY OF PRODUCTION

3.1. With regard to the materials used for the manufacture of lenses, the *installation units* of a series shall be recognized as complying with this Regulation if:

3.1.1. After the test for resistance to chemical agents and the test for resistance to detergents and hydrocarbons, the outer face of the samples exhibits no cracks, chipping or deformation visible to the naked eye (see paragraphs. 2.2.2., 2.3.1. and 2.3.2.);

3.1.2. After the test described in paragraph 2.6.1.1., the photometric values at the points of measurement considered in paragraph 2.6.1.2. are within the limits prescribed for conformity of production by this Regulation.

3.2. If the test results fail to satisfy the requirements, the tests shall be repeated on another sample of *systems* selected at random.

Annex 6 - Appendix 1

CHRONOLOGICAL ORDER OF APPROVAL TESTS

A. Tests on plastic materials (lenses or samples of material supplied pursuant to paragraph 2.2.4. of this Regulation)

Samples	Lenses or samples of material										Lenses			
	1	2	3	4	5	6	7	8	9	10	11	12	13	14
1.1 Limited photometry (para. 2.1.2)											X	X	X	
1.1.1. Temperature change (para.2.1.1.)											X	X	X	
1.2. Limited photometry (para. 2.1.2.)											X	X	X	
1.2.1. Transmission measurement	X	X	X	X	X	X	X	X	X					
1.2.2. Diffusion measurement	X	X	X				X	X	X					
1.3. Atmospheric agents (para. 2.2.1.)	X	X	X											
1.3.1. Transmission measurement	X	X	X											
1.4. Chemical agents (para.2.2.2.)	X	X	X											
1.4.1. Diffusion measurement	X	X	X											
1.5. Detergents (para. 2.3.1.)				X	X	X								
1.6. Hydrocarbons (para.2.3.2.)				X	X	X								
1.6.1. Transmission measurement				X	X	X								
1.7. Deterioration (para. 2.4.1.)							X	X	X					
1.7.1. Transmission measurement							X	X	X					
1.7.2. Diffusion measurement							X	X	X					
1.8. Adherence (para. 2.5.)														X
1.9. Resistance to light source radiation (para.2.2.4.)										X				

B. Tests on complete *systems or part(s) thereof* (supplied pursuant to paragraph 2.2.3. of this Regulation).

Tests	Complete Systems	
	Sample No.	
	1	2
2.1. Deterioration (para. 2.6.1.1.)	X	
2.2. Photometry (para. 2.6.1.2.)	X	
2.3. Adherence (para. 2.6.2.)		X



Annex 6 - Appendix 2

METHOD OF MEASUREMENT OF THE DIFFUSION AND TRANSMISSION OF LIGHT

1. EQUIPMENT (see Figure 1 below)

The beam of a collimator K with a half divergence $\beta/2 = 17.4 \times 10^{-4}$ rad is limited by a diaphragm D_τ with an opening of 6 mm against which the sample stand is placed.

A convergent achromatic lens L_2 , corrected for spherical aberrations links the diaphragm D_τ with the receiver R; the diameter of the lens L_2 shall be such that it does not diaphragm the light diffused by the sample in a cone with a half top angle of $\beta/2 = 14$ deg.

An annular diaphragm D_D , with angles $\alpha_o/2 = 1$ deg and $\alpha_{max}/2 = 12$ deg is placed in an image focal plane of the lens L_2 .

The non-transparent central part of the diaphragm is necessary in order to eliminate the light arriving directly from the light source. It shall be possible to remove the central part of the diaphragm from the light beam in such a manner that it returns exactly to its original position.

The distance $L_2 D_\tau$ and the focal length F_2 of the lens L_2 shall be so chosen that the image of D_τ completely covers the receiver R.

For L_2 it is recommended to use a focal distance of about 80 mm.

When the initial incident flux is referred to 1 the absolute precision of each reading shall be better than 0.001.

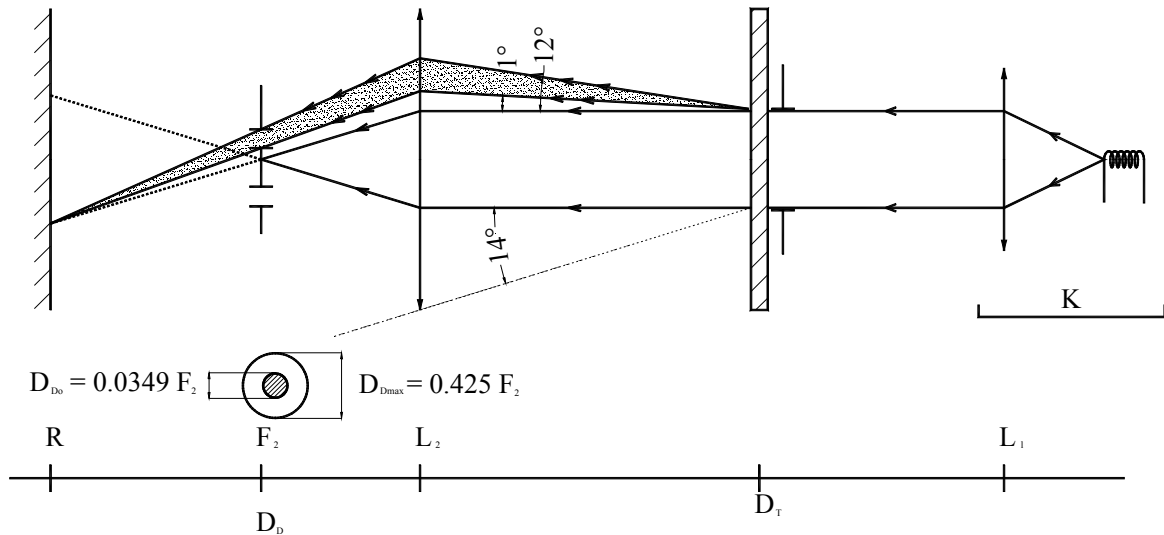

Figure 1: Optical set up for measurement of variations in diffusion and transmission

2. MEASUREMENTS

The following readings shall be taken:

Reading	With sample	With central part of D_D	Quantity represented
T_1	No	No	Incident flux in initial reading
T_2	Yes (before test)	No	Flux transmitted by the new material in a field of 24deg
T_3	Yes (before test)	No	Flux transmitted by the tested material in a field of 24deg
T_4	Yes (before test)	Yes	Flux diffused by the new material
T_5	Yes (before test)	Yes	Flux diffused by the tested material

Annex 6 - Appendix 3

SPRAY TESTING METHOD

1. Test equipment

1.1. Spray gun

The spray gun used shall be equipped with a nozzle 1.3 mm in diameter allowing a liquid flow rate of 0.24 ± 0.02 l/minute at an operating pressure of 6.0 bars $-0 / +0.5$ bar.

Under these operation conditions the fan pattern obtained shall be $170 \text{ mm} \pm 50 \text{ mm}$ in diameter on the surface exposed to deterioration, at a distance of $380 \text{ mm} \pm 10 \text{ mm}$ from the nozzle.

1.2. Test mixture

The test mixture shall be composed of:

Silica sand of hardness 7 on the Mohr scale, with a grain size between 0 and 0.2 mm and an almost normal distribution, with an angular factor of 1.8 to 2;

Water of hardness not exceeding 205 g/m^3 for a mixture comprising 25 g of sand per litre of water.

2. Test

The outer surface of the lamp lenses shall be subjected once or more than once to the action of the sand jet produced as described above. The jet shall be sprayed almost perpendicular to the surface to be tested.

The deterioration shall be checked by means of one or more samples of glass placed as a reference near the lenses to be tested. The mixture shall be sprayed until the variation in the diffusion of light on the sample or samples measured by the method described in Appendix 2, is such that: $\Delta d = (T_5 - T_4) / T_2 = 0.0250 \pm 0.0025$.

Several reference samples may be used to check that the whole surface to be tested has deteriorated homogeneously.

Annex 6 - Appendix 4

ADHESIVE TAPE ADHERENCE TEST

1. **PURPOSE**
This method allows to determine under standard conditions the linear force of adhesion of an adhesive tape to a glass plate.
 2. **PRINCIPLE**
Measurement of the force necessary to unstick an adhesive tape from a glass plate at an angle of 90deg.
 3. **SPECIFIED ATMOSPHERIC CONDITIONS**
The ambient conditions shall be at $23^{\circ}\text{C} \pm 5^{\circ}\text{C}$ and 65 ± 15 per cent relative humidity.
 4. **TEST PIECES**
Before the test, the sample roll of adhesive tape shall be conditioned for 24 hours in the specified atmosphere (see paragraph 3. above).

Five test pieces each 400 mm long shall be tested from each roll. These test pieces shall be taken from the roll after the first three turns were discarded.
 5. **PROCEDURE**
The test shall be under the ambient conditions specified in paragraph 3.

Take the five test pieces while unrolling the tape radially at a speed of approximately 300 mm/s, then apply them within 15 seconds in the following manner:

Apply the tape to the glass plate progressively with a slight length- wise rubbing movement of the finger, without excessive pressure, in such a manner as to leave no air bubble between the tape and the glass plate.

Leave the assembly in the specified atmospheric conditions for 10 minutes.

Unstick about 25 mm of the test piece from the plate in a plane perpendicular to the axis of the test piece.

Fix the plate and fold back the free end of the tape at 90deg. Apply force in such a manner that the separation line between the tape and the plate is perpendicular to this force and perpendicular to the plate.

Pull to unstick at a speed of $300 \text{ mm/s} \pm 30 \text{ mm/s}$ and record the force required.
 6. **RESULTS**
The five values obtained shall be arranged in order and the median value taken as a result of the measurement. This value shall be expressed in Newton per centimetre of width of the tape.
-

Annex 7

MINIMUM REQUIREMENTS FOR SAMPLING BY AN INSPECTOR

1. GENERAL

- 1.1. The conformity requirements shall be considered satisfied from a mechanical and a geometrical standpoint, if the differences do not exceed inevitable manufacturing deviations within the requirements of this Regulation. This condition also applies to colour.
- 1.2. With respect to photometric performances, the conformity of mass-produced *systems* shall not be contested if, when testing photometric performances of any *system* chosen at random and *equipped with a light source energized, and if applicable corrected, as prescribed in paragraphs 1. and 2. of annex 10 to this Regulation*
 - 1.2.1. no value *measured and corrected according to the prescriptions of paragraph 2. of annex 10 to this Regulation* deviates unfavourably by more than 20 per cent from the value prescribed in this Regulation;
 - 1.2.1.1. For the following values of the passing beam and its modes, the maximum unfavourable deviation may be respectively:
 - maximum values at point B50L 0.2lx equivalent 20 per cent and 0.3lx equivalent 30 per cent;
 - maximum values at zone III, HV and segment BLL: 0.3lx equivalent 20 per cent and 0.45lx equivalent 30 per cent;
 - maximum values at segments E, F1, F2 and F3: 0.2lx equivalent 20 per cent and 0.3lx equivalent 30 per cent;
 - minimum values at BR, P, S50, S50LL, S50RR, S100, S100LL, S100RR, and those required by footnote 4/ of table 1 in annex 3 of this Regulation (B50L, HV, BR, BRR, BLL): half of the required value equivalent 20 per cent and three quarter of the required value equivalent 30 per cent;
 - 1.2.1.2. for the driving beam, HV being situated within the isolux 0.75 E_{max}, a tolerance of +20 per cent for maximum values and -20 per cent for minimum values is observed for the photometric values at any measuring point specified in paragraph 6.3.2. of this Regulation.
 - 1.2.2. If the results of the test described above do not meet the requirements, the alignment of the *system* may be changed, provided that the axis of the beam is not displaced laterally by more than 0.5 deg to the right or left and not by more than 0.2deg up and down. *These provisions do not apply to lighting units as indicated under paragraph 6.3.1.1. of this Regulation.*
 - 1.2.3. If the results of the tests described above do not meet the requirements, tests shall be repeated using another standard (étalon) light source and/or another supply and operating device.
 - 1.2.4. *Systems* with apparent defects are disregarded.
 - 1.2.5. The reference mark is disregarded.

2. FIRST SAMPLING

In the first sampling four *systems* are selected at random. The first sample of two is marked A, the second sample of two is marked B.

2.1. The conformity is not contested

2.1.1. Following the sampling procedure shown in Figure 1 of this annex the conformity of mass-produced *systems* shall not be contested if the deviations of the measured values of the *systems* in the unfavourable directions are:

2.1.1.1. Sample A

A1: one *system* 0 per cent
one *system* not more than 20 per cent

A2: both *systems* more than 0 per cent
but not more than 20 per cent
go to Sample B

2.1.1.2. Sample B

B1: both *systems* 0 per cent

2.1.2. or if the conditions of paragraph 1.2.2. for Sample A are fulfilled.

2.2. The conformity is contested

2.2.1. Following the sampling procedure shown in Figure 1 of this annex the conformity of mass-produced *systems* shall be contested and the manufacturer requested to make his production meet the requirements (alignment) if the deviations of the measured values of the *systems* are:

2.2.1.1. Sample A

A3: one system not more than 20 per cent
one system more than 20 per cent
but not more than 30 per cent

2.2.1.2. Sample B

B2: in the case of A2
one system more than 0 per cent
but not more than 20 per cent
one system not more than 20 per cent

B3: in the case of A2
one system 0 per cent
one system more than 20 per cent
but not more than 30 per cent

2.2.2. or if the conditions of paragraph 1.2.2. for Sample A are not fulfilled.

2.3. Approval withdrawn

Conformity shall be contested and paragraph 10. applied if, following the sampling procedure shown in Figure 1 of this annex, the deviations of the measured values of the *systems* are:

- 2.3.1. Sample A
- | | | | |
|-----|--------------|---------------|-------------|
| A4: | one system | not more than | 20 per cent |
| | one system | more than | 30 per cent |
| A5: | Both systems | more than | 20 per cent |
- 2.3.2. Sample B
- | | | | |
|-----|-------------------|-------------------|-------------|
| B4: | in the case of A2 | | |
| | one system | more than | 0 per cent |
| | one system | but not more than | 20 per cent |
| | one system | more than | 20 per cent |
| B5: | in the case of A2 | | |
| | both systems | more than | 20 per cent |
| B6: | in the case of A2 | | |
| | one system | | 0 per cent |
| | one system | more than | 30 per cent |
- 2.3.3. or if the conditions of paragraph 1.2.2. for Samples A and B are not fulfilled.

3. REPEATED SAMPLING

In the case of A3, B2, B3 a repeated sampling, third Sample C of two *systems*, selected from stock manufactured after alignment, is necessary within two months' time after the notification.

- 3.1. The conformity is not contested
- 3.1.1. Following the sampling procedure shown in Figure 1 of this annex the conformity of mass-produced shall not be contested if the deviations of the measured values of the are:
- 3.1.1.1. Sample C
- | | | | |
|-----|----------------|-------------------|-------------|
| C1: | one system | | 0 per cent |
| | one system | not more than | 20 per cent |
| C2: | both systems | more than | 0 per cent |
| | | but not more than | 20 per cent |
| | go to Sample D | | |
- 3.1.1.2. Sample D
- | | | | |
|-----|-------------------|--|------------|
| D1: | in the case of C2 | | |
| | both systems | | 0 per cent |
- 3.1.2. or if the conditions of paragraph 1.2.2. for Sample C are fulfilled.
- 3.2. The conformity is contested
- 3.2.1. Following the sampling procedure shown in Figure 1 of this annex the conformity of mass-produced *systems* shall be contested and the manufacturer requested to make his

production meet the requirements (alignment) if the deviations of the measured values of the *systems* are:

3.2.1.1. Sample D

D2: in the case of C2		
one system	more than	0 per cent
	but not more than	20 per cent
one system	not more than	20 per cent

3.2.1.2. or if the conditions of paragraph 1.2.2 for Sample C are not fulfilled.

3.3. Approval withdrawn

Conformity shall be contested and paragraph 10. applied if, following the sampling procedure shown in Figure 1 of this annex, the deviations of the measured values of the *systems* are:

3.3.1. Sample C

C3: one system	not more than	20 per cent
one system	more than	20 per cent
C4: both systems	more than	20 per cent

3.3.2. Sample D

D3: in the case of C2		
one system		0 per cent
	or more than	0 per cent
one system	more than	20 per cent

3.3.3. or if the conditions of paragraph 1.2.2. for Samples C and D are not fulfilled.

4. CHANGE OF THE VERTICAL POSITION OF THE CUT-OFF LINE FOR PASSING BEAM

With respect to the verification of the change in vertical position of the cut-off line for passing beam under the influence of heat, the following procedure shall be applied:

One of the *systems* of Sample A after sampling procedure in Figure 1 of this annex shall be tested according to the procedure described in paragraph 2.1. of annex 4 after being subjected three consecutive times to the cycle described in paragraph 2.2.2. of annex 4.

The *system* shall be considered as acceptable if Δr does not exceed 1.5 mrad.

If this value exceeds 1.5 mrad but is not more than 2.0 mrad, the second *system* of Sample A shall be subjected to the test after which the mean of the absolute values recorded on both samples shall not exceed 1.5 mrad.

However, if this value of 1.5 mrad on Sample A is not complied with, the two *systems* of Sample B shall be subjected to the same procedure and the value of Δr for each of them shall not exceed 1.5 mrad.

Figure 1
 Note: "device" in this figure means "system"

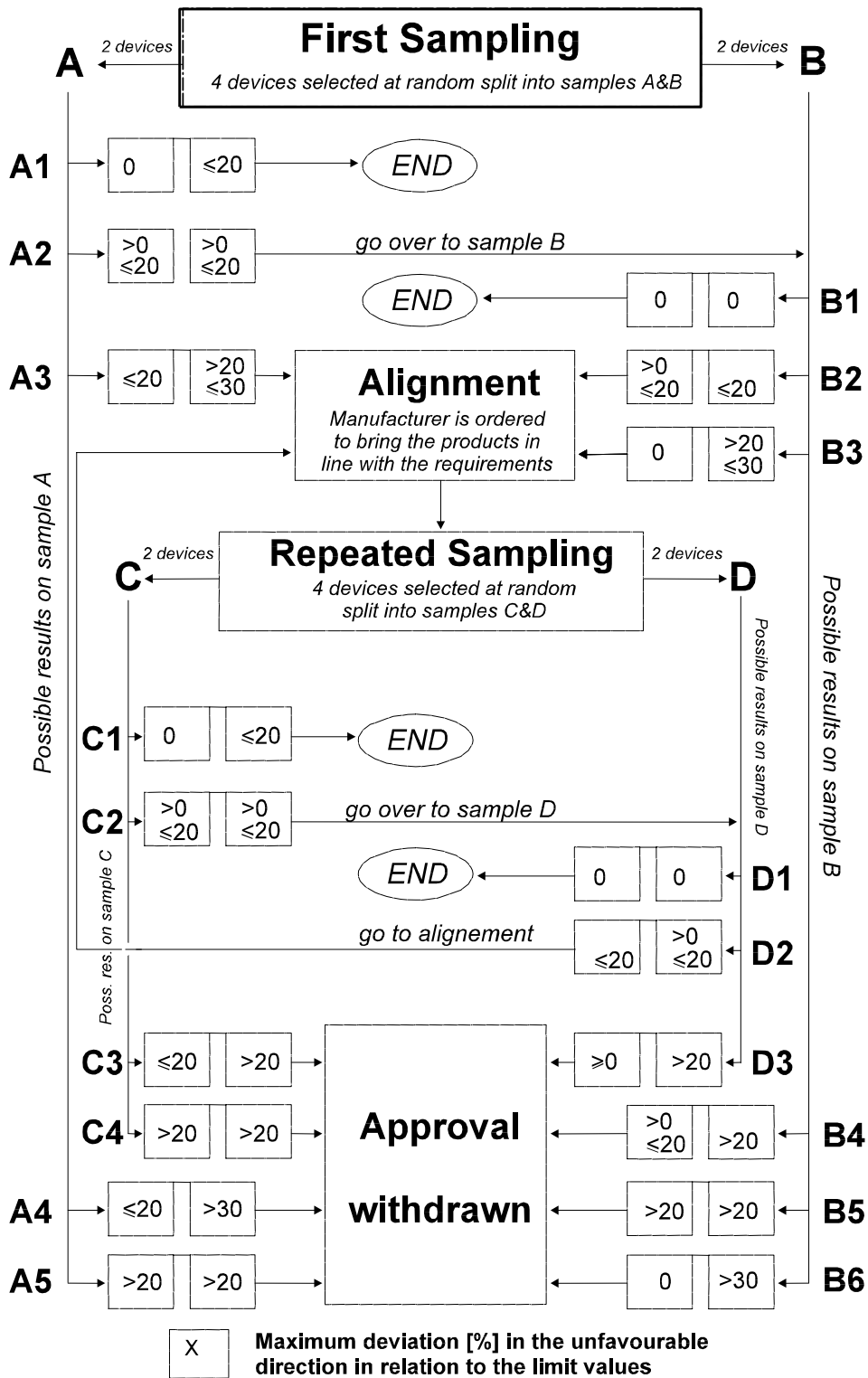

[Annex 8] under consideration /to be amended

REQUIREMENTS FOR SYSTEMS INCORPORATING [LIGHT SOURCE MODULES
AND/OR LIGHTING UNITS WITH] LIGHT SOURCES NOT BEING APPROVED
ACCORDING TO REGULATION NO. 37 OR 99

PART A: [LIGHT SOURCE MODULES OR LIGHTING UNITS WITH] GAS
DISCHARGE LIGHT SOURCE(S)

1. Definition.
"objective value" means the design value of an electrical or photometric characteristic. To be achieved, within the specified tolerances, when the gas discharge light source is energized by the electronic light source control-gear operated at the test voltage.
2. General specifications.
 - 2.1. Each light source module and/or lighting unit sample submitted shall conform to the relevant specifications of this Regulation when tested with the submitted electronic light source control-gear(s).
 - 2.2. *Gas discharge light sources shall be so designed as to be and to remain in good working order when in normal use. They shall moreover exhibit no fault in design or manufacture.*
3. *Manufacture.*
 - 3.1. *The transparent envelope (bulb) of the light source shall exhibit no marks or spots which might impair its efficiency and its optical performance.*
 - 3.2. *Light sources shall be equipped with suited fixation elements.*
 - 3.3. *The fixation elements shall be strong and firmly secured to the transparent envelope (bulb).*
4. *Tests.*
 - 4.1. *Light sources shall be aged as indicated in paragraph 9. below.*
 - 4.2. *All samples shall be tested with the submitted electronic light source control-gear.*
5. *Position and dimensions of elements for optical radiation (e.g. the discharge arc) and shielding (e.g. the stripes), if any:*
 - 5.1. *The geometric position and dimensions of the elements for optical radiation and shielding, if any, shall be as indicated on the submitted data sheet.*
 - 5.1.1. *The measurement shall be made using optical methods through transparent envelope (bulb), after ageing with the light source energized by the electronic light source control-gear at test voltage.*
 - 5.2. *The position and dimension and transmission of the stripes or shields, if any, shall be as indicated on the submitted data sheet.*
 - 5.2.1. *The measurement shall be made after ageing with the light source energized by the submitted electronic light source control-gear at test voltage.*

6. *Starting, run-up and hot-restrike characteristics.*

6.1. *Starting.*

When tested according to the conditions specified in paragraph 9. below, the light source shall start immediately and remain alight.

6.2. *Run-up.*

When measured according to the conditions specified in paragraph 9. below, the light source shall emit at least:

After 1 second: 25 per cent of its objective luminous flux;

After 4 seconds: 80 per cent of its objective luminous flux.

The objective luminous flux as indicated on the submitted data sheet.

6.3. *Hot-restrike.*

When tested according to the conditions specified in paragraph 9. below, the light source shall restart immediately after being switched-off for a period of 10 seconds. After one second the light source shall emit at least 80 per cent of its objective luminous flux.

7. **Minimum Red Content.**

The minimum red content of the light of a light source shall be such that:

$$k_{red} = \frac{\int_{\lambda=610nm}^{780nm} E_e(\lambda) V(\lambda) d\lambda}{\int_{\lambda=380nm}^{780nm} E_e(\lambda) V(\lambda) d\lambda} \geq 0,05$$

where:

$E_e(\lambda)$ (unit: W/nm) is the spectral distribution of the irradiance;
 $V(\lambda)$ (unit: 1) is the relative spectral luminous efficiency;
 λ (unit: nm) is the wavelength.

This value shall be calculated using intervals of one nanometre.

8. **Maximum UV- Content.**

The UV-radiation of the light source shall be such that:

$$k_{UV} = \frac{\int_{\lambda=250nm}^{400nm} E_e(\lambda) S(\lambda) d\lambda}{k_m \int_{\lambda=380nm}^{780nm} E_e(\lambda) V(\lambda) d\lambda} \leq 10^{-5} \text{ W / lm}$$

where:

$S(\lambda)$ (unit: 1) is the relative spectral weighting function;
 $k_m = 683$ (unit: lm/W) is the photometric radiation equivalent;
 (For definitions of the other symbols see paragraph 7. above).

This value shall be calculated using intervals of one nanometre. The UV-radiation shall be weighted according to the values as indicated in the Table UV below.

Table UV: Values according to "IRPA/INIRC Guidelines on limits of exposure to ultraviolet radiation". Wavelengths chosen are representative; other values should be interpolated.

λ/nm	$S(\lambda)/1$	λ/nm	$S(\lambda)/1$	λ/nm	$S(\lambda)/1$
250	0.430	305	0.060	355	0.000 16
255	0.520	310	0.015	360	0.000 13
260	0.650	315	0.003	365	0.000 11
265	0.810	320	0.001	370	0.000 09
270	1.000	325	0.000 50	375	0.000 077
275	0.960	330	0.000 41	380	0.000 064
280	0.880	335	0.000 34	385	0.000 053
285	0.770	340	0.000 28	390	0.000 044
290	0.640	345	0.000 24	395	0.000 036
295	0.540	350	0.000 20	400	0.000 030
300	0.300				

9. Method of measurement of electrical and photometric characteristics.
 - 9.1. General.
 For starting, run-up and hot-restrike tests and for the measurement of electrical and photometric characteristics, the gas-discharge light source shall be operated in free air with an ambient temperature of $25 \pm 5^\circ\text{C}$.
 - 9.2. Electronic light source control-gear.
 All tests and measurements shall be carried out with the electronic light source control-gear submitted in accordance with paragraph 2.2.3. of this Regulation. The power supply used for the starting and run-up tests shall be sufficient to secure the quick rise of the high current pulse.
 - 9.3. Burning position.
 The burning position shall be as indicated by the applicant. Ageing and testing positions shall be identical. If the lamp is accidentally operated in the wrong direction, it shall be re-aged before measurements begin. During ageing and measurements no electrically conducting objects shall be allowed within a space as indicated by the applicant. Moreover stray magnetic fields shall be avoided.
 - 9.4. Ageing.
 With the exception of the starting test, all tests shall be carried out with light sources which have been aged for a minimum of 15 cycles having the following switching cycle: 45 minutes on, 15 seconds off, 5 minutes on, 10 minutes off.
 - 9.5. Supply voltage.
 All tests shall be carried out at test voltage of 13.5 V or as indicated by the applicant.
 - 9.6. Starting test.
 The starting test shall be applied to light sources which have not been aged and have not been used for a period of at least 24 hours prior to the test.

- 9.7. Run-up test.
The run-up test shall be applied to light sources which have not been used for a period of at least 1 hour prior to the test.
- 9.8. Hot restrike test.
The light source shall be started and be operated with the electronic light source control-gear at test voltage for a period of 15 minutes. The supply voltage to the electronic light source control-gear shall then be switched off for a switch-off period of 10 seconds, and be switched on again.
- 9.9. Electrical and photometric test.
Before any measurement, the light source shall be stabilised for a period of 15 minutes.
- 9.10. Colour.
The colorimetric properties of the light source shall be measured in an integrating sphere using a measuring system, which shows the CIE chromaticity co-ordinates of the received light with a resolution of ± 0.002 .

PART B: [LIGHT SOURCE MODULES OR LIGHTING UNITS WITH] OTHER LIGHT SOURCE(S)

10. The technical requirements of paragraphs 3. through 9. of part A of this annex apply, where relevant.
-

[Annex 9] under consideration /to be amended

PASSING BEAM "CUT-OFF" AND AIMING PROVISIONS

1. The "cut-off" line of a passing beam shall comply with the following requirements (see Fig. A.9-1 below):
 - 1.1. The "cut-off" line shall consist of
 - (i) a straight "horizontal part" towards the left
 - (ii) a "shoulder line part" towards the right
 - (iii) one clear "kink", in between and formed by the "cut-off" parts defined above,
 - 1.2. which meet the following specifications:
 - 1.2.1. the "horizontal part" does not exceed a vertical extend of $\Delta\beta = 0.2$ deg up or down within 0.5 deg and 4.5 deg left from the "kink";
 - 1.2.2. the "shoulder line part"
 - (a) does not extend more than $\Delta\beta = 0.2$ deg above the line "B" going from the "kink" upwards to the right and being inclined versus H-H by 60 deg;
 - (b) does not extend more than $\Delta\beta = 0.2$ deg below the line "A" going from the "kink" upwards to the right and being inclined versus H-H by 10 deg, or, by 0 deg if it is a class V passing beam, or if, according to the applicants specification, no separate horizontal adjustment of the respective lighting unit is foreseen;
 - (c) has a vertical extension of at least $\Delta\beta = 0.57$ deg, if it is a class C ~~(basic)~~ passing beam, or, it shall reach at least to H-H, in case of a class E or a class W passing beam, except if, according to the applicants specification, no separate horizontal adjustment of the respective lighting unit is foreseen;
 - 1.3. If there is no distinct "kink", the "kink point" shall be considered to be that point, where the 60 deg tangential line to the "shoulder line part" meets the prolonged mean line of the "horizontal part" (for examples see Fig. A.9-2 below).
2. Visual adjustment by means of the "cut-off"
 - 2.1. For horizontal adjustment the class C ~~(basic)~~ passing beam shall be so positioned that the "kink" of the "elbow" of its "cut-off" line is situated at the V-V-line.

For lighting units contributing to the passing beam but providing no "cut-off" or a horizontal "cut-off" line only, no special requirements for horizontal adjustment apply if not specified by the applicant.
 - 2.2. For the vertical adjustment the class C ~~(basic)~~ passing beam shall be positioned such, that the horizontal part of its "cut-off" line is situated at the nominal vertical position according to the respective requirements indicated in Table 2 of annex 3 to this Regulation (see Fig. A.9-3 below).
 - 2.2.1. If the "horizontal part" of the "cut-off" line does not provide sufficient linearity and/or sharpness for a visual vertical adjustment the "cut-off" quality shall be evaluated for

compliance with provisions laid down in paragraph 3. below, according to the discretion of the Technical Service.

- 2.3. for each class, other than the class C (~~basic~~) passing beam:
the shape and position of the "cut-off", if any, shall comply (automatically) with the respective requirements of Table 2 of annex 3 to this Regulation, when said passing beam is switched on. A separate initial aiming and/or adjustment process according to the applicant's specification may apply to lighting units intended to be installed separately.
3. "cut-off" quality evaluation ^{1/}:
 - 3.1. Measurements of the illumination E on the aiming screen are performed by vertical scanning through the "horizontal part" of the "cut-off" in steps of $[\Delta\beta=0.04]$ **not exceeding 0.05 deg** of the vertical angle β , using a receiver cell with a 10 mm vertical aperture at 10m distance or at any greater distance with a vertical aperture of the receiver cell of 1/1000 of the measuring distance.

After visual horizontal adjustment according to paragraph 2.1. above, the scanning is done at 1.5 deg, 2.5 deg and 3.5 deg left of V-V.
 - 3.2. When so measured, the following conditions shall be met:
 - 3.2.1. No double lines allowed:
In case a "cut-off" serves, according to the Applicants specification, for aiming purposes, no secondary "cut-off line" (double line) shall be produced from the same lighting unit.

A double line shall be deemed not being detrimental if its sharpness factor G, as defined in the paragraph 3.2.2. below, is less than [0.10].
 - 3.2.2. Sufficient sharpness:
the maximum value of $(\log E_{\beta} - \log E_{(\beta+0.1^{\circ})})$ evaluated at 2.5 deg left of V-V, is called the "sharpness factor" G of the "cut-off". G shall not be less than 0.13.
 - 3.2.3. Sufficient linearity:
the straightness of the "horizontal part" of the "cut-off" line is deemed sufficient, if the vertical positions where $d^2(\log E_{\beta})/d\beta^2=0$ of each vertical scanning line according paragraph 3.1. above, are located within a bandwidth of ± 0.2 deg from the mean of all values.
 4. Instrumental vertical adjustment:
If the "cut-off" line complies with the requirements set out in paragraph 3. above, the vertical adjustment may be performed with other means instead visually.

^{1/} For background information see CIE CONGRESS REPORT 1979, KYOTO.

Figures A.9-1 through A.9-3

Note: In the figures the "cut-off" is shown schematically, projected on the aiming screen, and for a system designed for right-hand traffic; [for left-hand traffic, the sides have to be mirrored.]

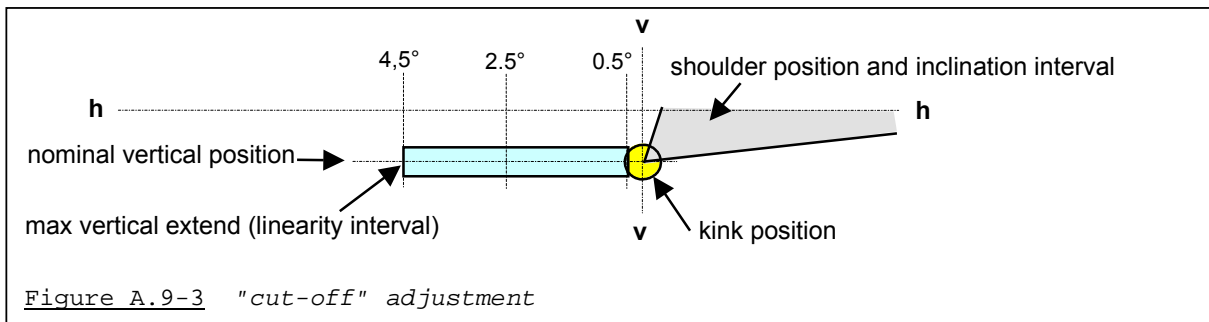
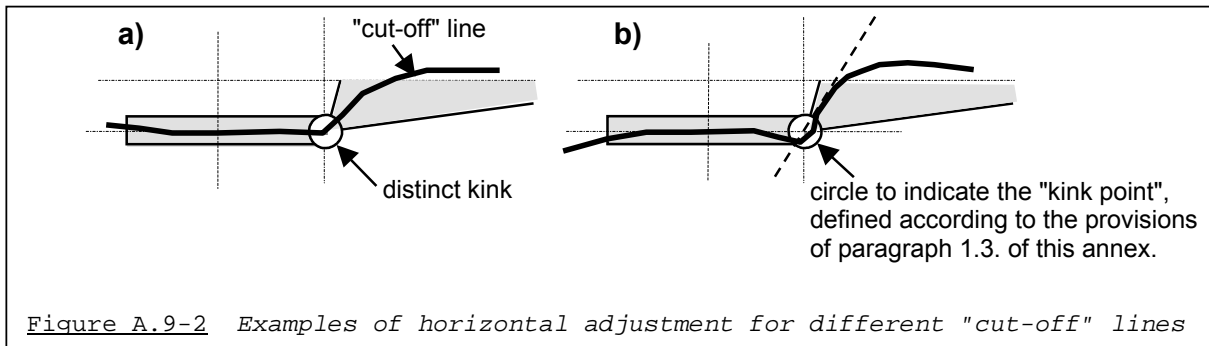
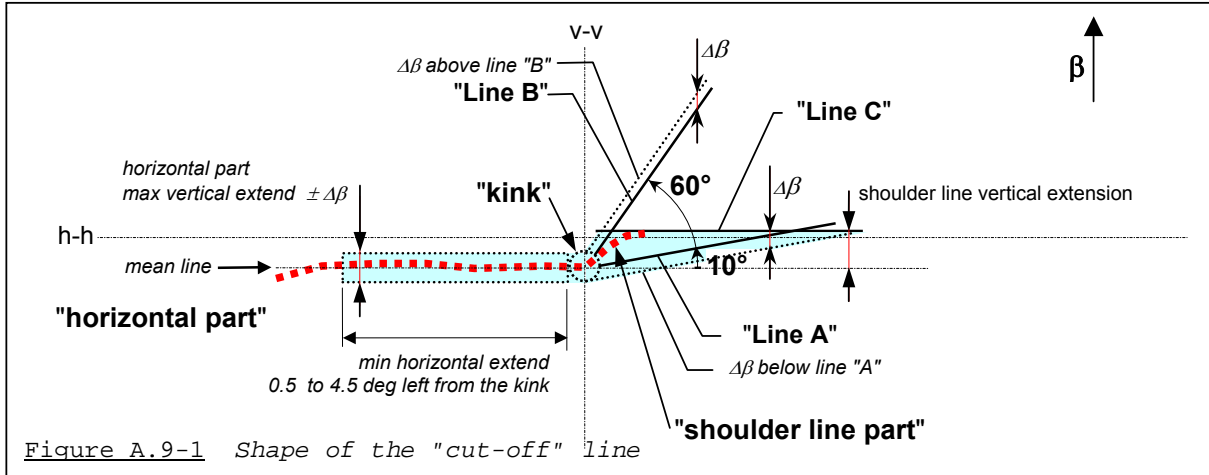

Annex 10

PHOTOMETRIC MEASUREMENT PROVISIONS

1. General provisions.
 - 1.1. The system or part(s) thereof shall be mounted on a goniometer with a fixed horizontal axis and moveable axis perpendicular to the fixed horizontal axis.
 - 1.2. The illuminance values shall be determined by means of a photoreceptor contained within a square of 65 mm side and set up to a distance of at least 25 m forward of the centre of reference of each lighting unit perpendicular to the measurement axis from the origin of the goniometer;
 - 1.3. During photometric measurements, stray reflections should be avoided by appropriate masking.
 - 1.4. The luminous intensities are measured and specified in form of illuminance values perpendicular to the direction of measurement, and, for a nominal distance of 25 m.
 - 1.5. The angular co-ordinates are specified in deg on a sphere with a vertical polar axis according to CIE publication No. 70, Vienna 1987, i.e. corresponding to a goniometer with a horizontal ("elevation") axis fixed to the ground and a second, moveable ("rotation") axis perpendicular to the fixed horizontal axis.
 - 1.6. Any equivalent photometric method is acceptable, if the accordingly applicable correlation is observed.
 - 1.7. Any offset of the centre of reference of each lighting unit, with respect to the goniometer rotation axes, should be avoided. This applies especially to the vertical direction and to lighting units producing a "cut-off".

An aiming screen shall be used and may be located at a shorter distance than that of the photoreceptor.
 - 1.8. The photometric requirements for each single measuring point (angular position) of a lighting function or mode as specified in this Regulation apply to half of the sum of the respective measured values from all lighting units of the system applied for this function or mode, or, from all lighting units as indicated in the respective requirement;
 - 1.8.1. however in those cases where a provision is specified for one side only, the division by the factor of 2 does not apply. These cases are: paragraphs 6.3.2.1.2. and 6.3.2.1.3., 6.4.1. and 6.4.2., 6.4.6., note 4 of Table 1, Annex 3, and paragraph 3.2. of Annex 9.
 - 1.9. The lighting units of the system shall be measured individually;

however, simultaneous measurements may be performed on two or more lighting units of an installation unit, being equipped with the same light source types with respect to their power supply (either power controlled or not), if they are sized and situated such, that their illuminating surfaces are completely contained in a rectangle of not more than 300 mm in horizontal extend and not more than 150 mm vertical extend, and, if a common centre of reference is specified by the manufacturer.

- 1.10. The system shall prior to the subsequent test procedures be set to the neutral state.
- 1.11. The system or part(s) thereof shall be so aimed before starting the measurements that the position of the "cut-off" complies with the requirements indicated in the Table 2 of annex 3 to this Regulation. Parts of a system measured individually and having no "cut-off" shall be installed on the goniometer under the conditions (mounting position) specified by the applicant.
2. Measurement conditions with respect to light sources
 - 2.1. In the case of replaceable filament lamps operated directly under vehicle voltage system conditions:

The system or parts thereof shall be checked by means of an uncoloured standard (étalon) filament lamp(s) designed for a rated voltage of 12 V. During checking of the system or part of, the voltage at the terminals of the filament lamp(s) shall be regulated so as to obtain the reference luminous flux as indicated at the relevant data sheet of Regulation No. 37.

The system or parts thereof shall be considered acceptable if the requirements of the paragraph 6. of this Regulation are met with at least one standard (étalon) filament lamp, which may be submitted with the system.
 - 2.2. In the case of a replaceable gas-discharge light source:

The system or parts thereof using a replaceable gas-discharge light source shall comply with the photometric requirements set out in the relevant paragraphs of this Regulation with at least one standard (étalon) light source, which has been aged during at least 15 cycles, in accordance with paragraph 9.4. of annex 8, to this Regulation. The luminous flux of this gas-discharge light source may differ from the objective luminous flux specified in Regulation No. 99.

In this case, the measured photometric values shall be corrected accordingly. They shall be multiplied by a factor of 0.7 prior to the check for compliance.
 - 2.3. In the case of a non-replaceable light source operating directly under vehicle voltage system conditions:

All measurements on lamps equipped with non-replaceable light sources (filament lamps and other) shall be made at 6.75 V, 13.5 V or 28.0 V, or at a voltage as specified by the Applicant with respect to any other vehicle voltage system. The measured photometric values shall be multiplied by a factor of 0.7 prior to the check for compliance.
 - 2.4. In the case of a light source, replaceable or non-replaceable, which is operated independently from vehicle supply voltage and fully controlled by the system, or in the case of a light source supplied by a special power supply, the test voltage as specified in paragraph 2.3. above shall be applied to the input terminals of that power supply. The test laboratory may require from the manufacturer this special power supply needed to supply the light sources.

The measured photometric values shall be multiplied by a factor of 0.7 prior to the check for compliance, except if this correction factor is already applied according to the provisions of paragraph 2.2. above.

3. Measurement conditions with respect to bending modes
 - 3.1. In the case of a system or part(s) thereof, which provide a bending mode, the requirements of paragraphs 6.2. (passing beam), and/or 6.3. (driving beam) of this Regulation apply for all states, corresponding to the turn radius of the vehicle. For verification with respect to the passing beam and the driving beam the following procedure shall be used:
 - 3.1.1. The system shall be tested in the neutral state (central/straight), and, in addition in the state(s) corresponding to the smallest turn radius of the vehicle in both directions using the signal generator, if applicable.
 - 3.1.1.1. Compliance with the requirements of paragraphs 6.2.6.2., 6.2.6.3. and 6.2.6.5.1. of this Regulation shall be checked for both category 1 and category 2 bending modes without additional horizontal re-aim.
 - 3.1.1.2. Compliance with the requirements of paragraphs 6.2.6.1. and 6.3. of this Regulation, whichever applies, shall be checked:

in case of a category 2 bending mode: without additional horizontal re-aim;

in case of a category 1 or a driving beam bending mode: after having horizontally re-aimed the relevant installation unit (by means of the goniometer for example) in the corresponding opposite direction.
 - 3.1.2. When testing a category 1 or category 2 bending mode, for a turn radius of the vehicle other than specified in paragraph 3.1.1. above: it shall be observed whether the light distribution is substantially uniform and no undue glare occurs. **If this can not be confirmed the compliance with the requirements laid down in table 1 of annex 3 to this Regulation shall be checked.**

Annex 11

DESCRIPTION FORMS
maximum format: A4 (210 x 297 mm)

ADAPTIVE FRONT-LIGHTING SYSTEM DESCRIPTION FORM NO. 1

AFS control signals relevant to the lighting functions, and modes of functions provided by the system

AFS Control Signal	function/mode(s) of, being influenced by the signal <u>1/</u>					driving beam	technical characteristics <u>2/</u> (use separate sheet, if needed)
	Passing beam						
	Class C	Class V	Class E	Class W			
None / default	<input checked="" type="checkbox"/>					<input type="checkbox"/>	
V-Signal	<input type="checkbox"/>	<input type="checkbox"/>	<input type="checkbox"/>	<input type="checkbox"/>		<input type="checkbox"/>	
E-Signal	<input type="checkbox"/>	<input type="checkbox"/>	<input type="checkbox"/>	<input type="checkbox"/>		<input type="checkbox"/>	
W-Signal	<input type="checkbox"/>	<input type="checkbox"/>	<input type="checkbox"/>	<input type="checkbox"/>		<input type="checkbox"/>	
T-Signal	<input type="checkbox"/>	<input type="checkbox"/>	<input type="checkbox"/>	<input type="checkbox"/>		<input type="checkbox"/>	
other Signals <u>3/</u>	<input type="checkbox"/>	<input type="checkbox"/>	<input type="checkbox"/>	<input type="checkbox"/>		<input type="checkbox"/>	

1/ mark in the respective box(es) with an cross (X) the combination(s) which apply.

2/ to be indicated in terms of:

- physical nature (electrical current/ voltage, optical, mechanical, hydraulic, pneumatic, ...)
- information type (continuous/analogous, binary, digitally coded,..)
- time dependent properties (time constant, resolution, ..)
- signal status when the respective conditions according to paragraph 6.20.7.2. of Regulation No. 48 are fulfilled
- signal status in case of failure (with reference to the system input)

3/ according to the Applicants description; use separate sheet, if needed.

[ADAPTIVE FRONT-LIGHTING SYSTEM DESCRIPTION FORM NO. 2

Cut-off status, adjustment devices and adjustment procedures relevant to the lighting units

lighting unit No. <u>1/</u>	cut-off status <u>2/</u>		adjustment device				characteristics & special adjustment criteria (if any) <u>5/</u>
	The lighting unit provides or contributes to one or more passing beam cut-off(s),		vertical		horizontal		
	as defined in annex 9 of this Regulation <u>3/</u>	and provisions of paragraph 5.2.1.2. of this Regulation apply <u>3/</u>	individual <u>3/</u>	joint with lighting unit(s) no. <u>4/</u>	individual <u>3/</u>	joint with lighting unit(s) no. <u>4/</u>	
1	yes / no	yes / no	yes / no	yes / no	
2	yes / no	yes / no	yes / no	yes / no	
3	yes / no	yes / no	yes / no	yes / no	
4	yes / no	yes / no	yes / no	yes / no	
5	yes / no	yes / no	yes / no	yes / no	
6	yes / no	yes / no	yes / no	yes / no	
7	yes / no	yes / no	yes / no	yes / no	

- 1/ designation of each individual lighting unit of the system as indicated in annex 1 to this Regulation and as shown in the drawing according to paragraph 2.2.1. of this Regulation; use separate sheet(s) if needed.
- 2/ relevant to provisions of paragraph 6.20.6.1.3. of Regulation No. 48
- 3/ strike out what does not apply.
- 4/ indicate corresponding lighting unit(s) number(s), if applicable.
- 5/ Information such as e.g.: the order of adjustment of lighting units or assemblies of lighting units, any additional optical criteria for the adjustment process, as e.g. a systematically required offset between two cut-offs on the 10 m-screen.]