

Profiling and data collection

UNECE Workshop Geneve



Centraal Bureau
voor de Statistiek

April 2019
Fred Demollin

Content:

- Profiling
- Example
- Conclusions

Profiling

- LCU population:
 - Active Profiling; action when needed based on:
 - Sources
 - Contacts
 - Internet/newspapers
 - Consistency problems T-1
 - Maintenance rather than new profiles
 - Information to other departments by profile reports
 - “Collection agreements”



Example:

1 EG

2 EG

1 EG

1 EG

EG A

EG A

EG A''

EG A

EG A

Ent A

Ent A

Ent A''

Ent A

Ent A



2019

Jan

Apr

Oct

Dec



Example:

1 EG

2 EG

1 EG

1 EG

EGA

EGA EGA''

EGA

EGA

Ent A

Ent A

Ent A''

Ent A

Ent A

B C D

B C D

B C

B C

2019

Jan

Apr

Oct

Dec



Example:

1 EG

2 EG

1 EG

1 EG

EGA

EGA EGA''

EGA

EGA

Ent A

Ent A

Ent A

Ent A

B C D

B C D

B C

B C

2019

Jan

Apr

Oct

Dec



Example:

1 EG

2 EG

1 EG

1 EG

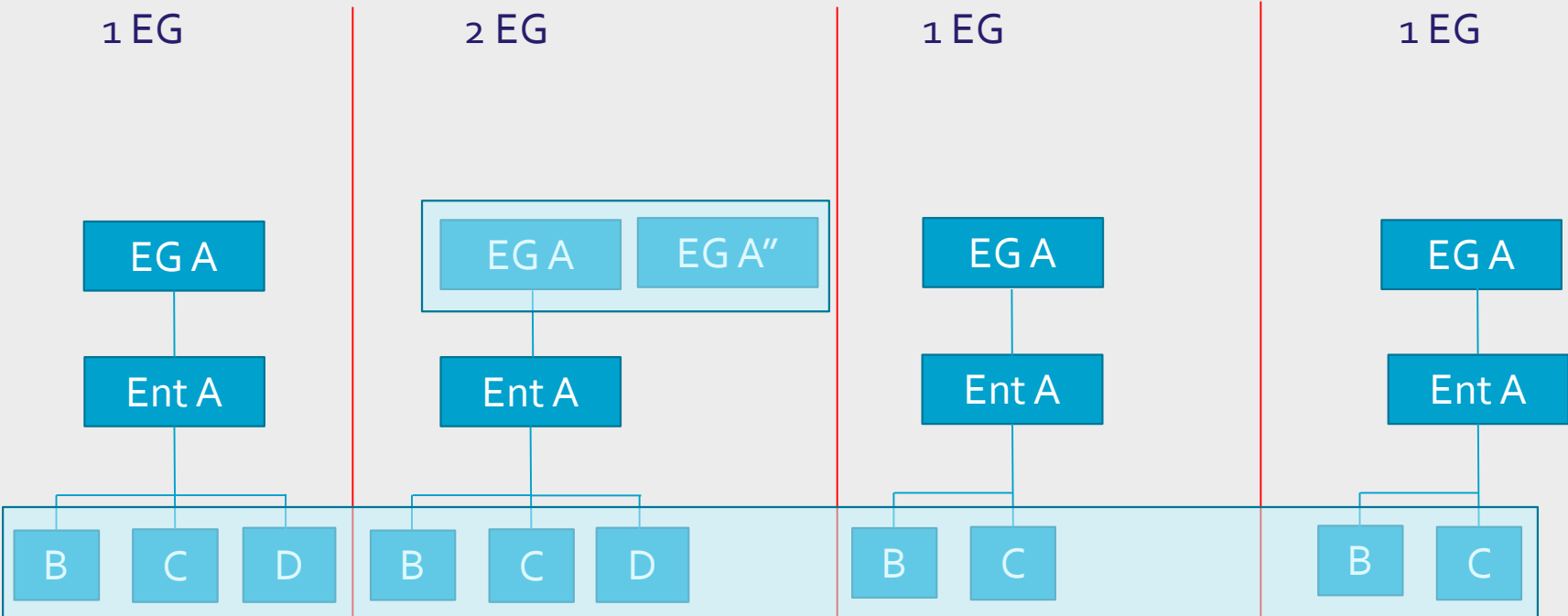

2019

Jan

Apr

Oct

Dec



Conclusions

- Data collection is prepared in time by special “Collection agreement”
- LEU “D” is not in the final frame of year 2019
- Due to special “Collection agreement” the respondent knows how to fill in the data
- LEU “D” has a yearly turnover of 9 Billion Euro; will be reported until October in NL

Profiling is vital for correct data collection, especially for groups in LCU population.