

ECONOMIC COMMISSION FOR EUROPE

INLAND TRANSPORT COMMITTEE

Working Party on the Construction of Vehicles

REVISED PROPOSAL FOR DRAFT 06 SERIES OF AMENDMENTS TO
REGULATION No.14
(UNIFORM PROVISIONS CONCERNING THE APPROVAL OF VEHICLES WITH
REGARD TO SAFETY-BELT ANCHORAGES)

Transmitted by the French Delegation

This amendment has been prepared to introduce in Regulation n°14 the new anchorage system standard for child restraint systems (CRS) prepared by the International Organization for Standardization (ISO).

The International Standard ISO 13216-1:1999 establishes an anchorage system composed of universal anchorage to be located in vehicle and universal attachment to be located on ISOFIX child restraint systems.

Following modifications of Regulation n°14 are suggested as draft 06 amendment series in which,

- (1) “ISOFIX” will be used as a qualificative adjective in order to simplify the modification redaction and to allow child restraint system users to be able to identify ISOFIX restraints without any doubt,
- ²(2) words copied from the International Standard ISO 13216-1:1999 will be written in *italics*,
- (3) words removed from the original text of Regulation n°14 will be written between brackets and crossed out,
- (4) words added to the original text of Regulation n°14 will be written in **bold types**

➤ In paragraph 1. SCOPE, add after the end of the sentence :

1. It also applies to ISOFIX anchorage systems intended to ISOFIX child restraint systems installed in vehicle of category M1 and N1.

➤ In paragraph 2. DEFINITIONS,

➤ add in the following paragraph to read :

2.2. “Vehicle type”
...to which the **safety belts anchorages and the ISOFIX anchorage systems if any** are attached...

➤ insert new paragraphs to read :

2.17. “ISOFIX anchorage”
means one 6 mm diameter rigid round horizontal bar, extending from vehicle or seat structure to accept and restraint an ISOFIX child restraint system with ISOFIX attachments.

2.18. “ISOFIX anchorage systems”
means a system including two ISOFIX anchorages which is designed for attaching an ISOFIX child restraint system.

2.19. “ISOFIX attachment”
means one of two connections, fulfilling the requirements. of regulation 44, extending from the ISOFIX child restraint system structure, and compatible with an ISOFIX anchorage.

2.20. “ISOFIX child restraint systems”
means an ISOFIX child restraint systems intended to be attached to ISOFIX anchorage systems.

2.21. “Seat bight”
means the area close to the intersection of the surfaces of the vehicle seat cushion and the seat back.

2.22. “Static force application device (S-FAD)”
means a test fixture that engages the vehicle ISOFIX anchorage system and that is used to verify their strength and stiffness in a static test. The test fixture is describe in the figures 1 and 2.

➤ In paragraph 3. APPLICATION FOR APPROVAL, add in the following paragraphs to read :

3.1. ...with regard to the belt anchorages and the ISOFIX anchorage systems if any shall be submitted...

- 3.2.1. ...showing the positions of the belt anchorages **and of the ISOFIX anchorage systems if any**, the effective belt anchorages (where appropriate), and detailed drawings of the belt anchorages **and of the ISOFIX anchorage systems if any** and of the point...
- 3.2.2. ...of the belt anchorages **and of the ISOFIX anchorage systems if any** ;
- 3.2.3. ...of the belt anchorages **and of the ISOFIX anchorage systems if any** ;
- 3.2.4. ...of belt anchorages **and of the ISOFIX anchorage systems if any** affixed to the seat structure ;
- 3.3. ...for the belt anchorage test **and for the ISOFIX anchorage systems test if any** by the technical...

➤ In paragraph 4. APPROVAL, the following paragraphs must be rewording to read :

- 4.2. ...Its first two digits (at present 06, corresponding to the 06 series of amendments)...

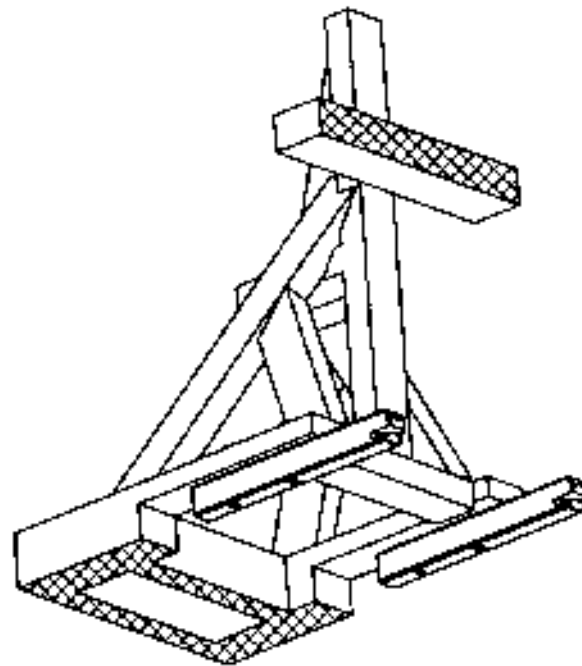
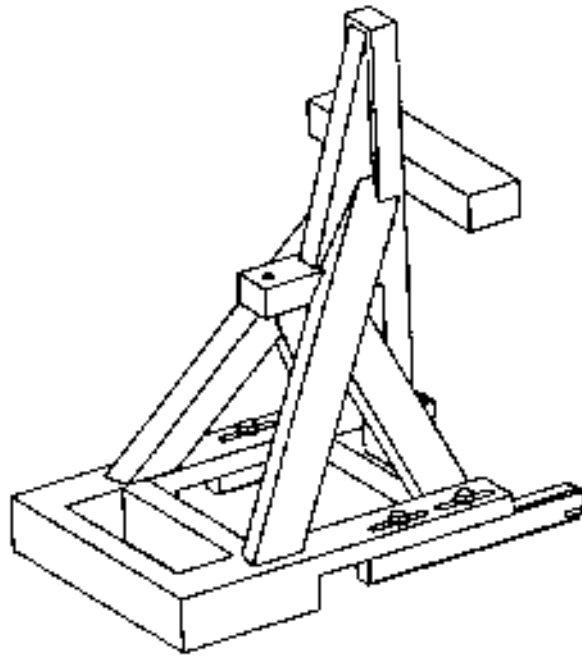

Figure 1 : Static force application device (S-FAD), isometric views

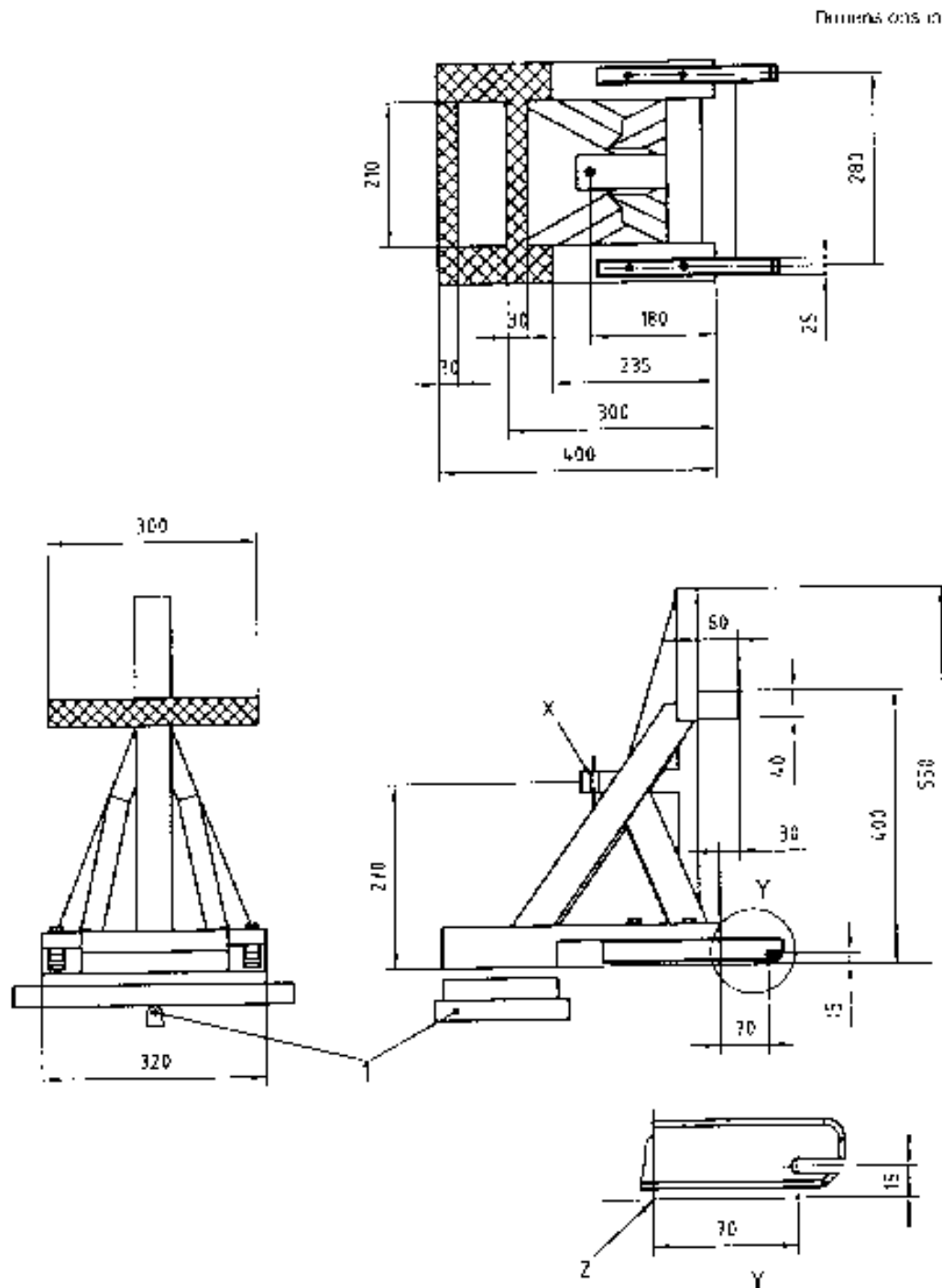

Figure 2 : Static force application device (S-FAD), dimensions

Stiffness of S-FAD : When attached to rigid anchorage bar(s) with the front cross member of the S-FAD supported by a rigid bar that is held at the centre by a longitudinal pivot 25mm below the S-FAD base (to allow bending and twisting of the S-FAD base) the movement of point X shall not be greater than 2 mm in any direction when forces are applied in accordance with table n°1 of paragraph 6.6.4. of this regulation. Any deformation of the ISOFIX anchorage system shall be excluded from the measurements. The stiffness requirements will be fulfilled when using a securely welded construction consisting of rectangular 3mm steel tubing, and 6mm thick load application plate.

➤ In paragraph 5. SPECIFICATIONS,

➤ insert new paragraphs to read :

- 5.2.2** **ISOFIX anchorage systems for ISOFIX child restraint system shall be designed, made and situated as to :**
- 5.2.2.1.** *The ISOFIX anchorage systems shall be 6 mm ± 0,1 mm diameter transverse horizontal rigid bar(s) which cover(s) two zones of 25 mm minimum effective length located on the same axes. For any ISOFIX anchorage systems, the distance between the centres of the two zones is 280 mm ± [to be defined] mm.*
The ISOFIX anchorage systems shall be supported so as to extend from the adjacent vehicle or seat structure.
- 5.2.2.2.** **ISOFIX anchorage systems shall be designed such as enable the vehicle, in normal use, to comply with the provisions of this regulation.**
- 5.3.10.** **Minimum number of ISOFIX anchorage systems to be provided.**
- 5.3.10.1.** **Any vehicle of category M1 must be equipped at least with two ISOFIX anchorage systems which satisfy the requirements of this regulation.**
- 5.3.10.1.1.** **Notwithstanding with 5.3.10.1. only one ISOFIX anchorage system shall be provided on the front seat row in the case of the two following vehicle concepts :**
-Either, no rear seat row is provided or,
-There is not enough sufficient space available between two seat rows measured as follows : with the seats and seat backs adjusted as specified in paragraph 5.3.10.1.1.1., the distance measured along a longitudinal horizontal line tangent to the highest point of the rear seat bottom in the suitable longitudinal vertical plane describe in paragraph 5.3.10.1.1.2. between the rearward surface of the front seat back and the forward surface of the rear seat back is less than 720 mm.
- 5.3.10.1.1.1.** **Adjustable seats are in the adjustment position midway between the forwardmost and rearmost positions, and if separately adjustable in a vertical direction, are at the lowest position. If an adjustment position doesn't exist midway between the forwardmost and rearmost positions, the closest adjustment position to the rear of the midpoint is used.**
Place adjustable seat backs in the manufacturer's nominal design riding position in the manner specified by the manufacturer
- 5.3.10.1.1.2.** **In a vehicle equipped with front separate side by side seats, the vertical plane to be taken into account in paragraph 5.3.10.1.1. is located at the centreline of the driver's seat cushion.**
In a vehicle equipped with front bench seating, the reference vertical plane mentioned above passes through the centre of the steering wheel rim.

5.3.10.1.2. Notwithstanding with 5.3.10.1. in case of integrated “built in” child restraint system(s) the number of ISOFIX anchorage systems to be provided shall be at least two minus the number integrated “built in” child restraint system(s).

➤ Renumber paragraph 5.3.10. (former) as paragraph 5.3.11.

➤ In paragraph 6.TESTS :

➤ The following sub-paragraph must be rewording as follow :

6.1. **General for seat belt anchorages tests.**

6.2. **Securing the vehicle for seat belt anchorages tests and for ISOFIX anchorage systems tests.**

6.2.1. ...as to strengthen the seat belt anchorages or the ISOFIX anchorage systems and their anchorage area...

6.3. **General test requirements for seat belt anchorages.**

6.4 **Particular test requirements for seat belt anchorages.**

➤ Insert new paragraphs to read :

6.6 *Static test requirements for ISOFIX anchorage systems.*

6.6.1. *The strength of the ISOFIX anchorage systems shall be tested applying the forces, as prescribed in paragraph 6.6.4., to the static force application device (S-FAD) with ISOFIX attachments well engaged. In case of several ISOFIX anchorage systems are installed on a seat row, the test shall be carried out simultaneously with all the ISOFIX anchorage systems fitted on this seat row.*

6.6.2. *The test may be carried out either on a completely finished vehicle or on sufficient parts of the vehicle so as to be representative of the strength and rigidity of the vehicle structure.*

Windows and doors may be fitted or not and closed or not.

Any fitting normally provided and likely to contribute to the vehicle structure may be fitted.

The test may be restricted to the ISOFIX anchorage systems relating to only one seat or group of seat on the condition that :

- The ISOFIX anchorage systems concerned have the same structural characteristics as the ISOFIX anchorage systems relating to the other seats or group of seats and,
- Where such ISOFIX anchorage systems are fitted totally or partially on the seat or group of seats, the structural characteristics of the seat or group of seats are the same as those for the other seats or groups of seats.

6.6.3. If the seats are adjustable, they shall be placed in the position recommended by the car manufacturer as specified by the paragraph 11 of this regulation.

6.6.4. *Forces, directions and excursion limits.*

6.6.4.1. *A force of 135N \pm 15N shall be applied to the centre of the lower front crossbar of the S-FAD in order to adjust the fore-aft position of the S-FAD rearward extension to remove any slack or tension between the S-FAD and its support.*

6.6.4.1. *Forces shall be applied to the static force application device (S-FAD) in forward and lateral directions according to table 1.*

Table 1 : Directions of test forces

<i>Forward</i>	<i>0° \pm 5°</i>	<i>8 kN \pm 0,25 kN</i>
<i>Lateral</i>	<i>75° \pm 5° (to both sides of straight forward or if any worst case side)</i>	<i>5 kN \pm 0,25 kN</i>

Forces in the forward direction shall be applied with an initial force application angle of 10 \pm 5° above the horizontal. Lateral forces shall be applied horizontally 0° \pm 5°. A pre-load force of 500 N \pm 25 N shall be applied at the prescribe loading point X indicated in figure 2. Full application of the force shall achieved within a period of 2 s or less. The force shall be maintained for a minimum period of 0,2 s.

6.6.4.2. *Horizontal excursion (after pre-load) of point X during application of the 8 kN and 5 kN forces shall be within the limits specified in Table 2. Rotation (yaw) of the fixture during application of the 8 kN forward force shall not exceed [15°]. All measurements shall be made according to ISO6487 with CFC of 60 Hz or any equivalent method.*

6.6.4.3. *Permanent deformation including partial rupture or breakage of any ISOFIX anchorage or surrounding area shall not constitute failure if the required force is sustained for the specified time.*

Table 2 : Excursions limits

<i>Force direction</i>	<i>Maximum excursion of point X of S-FAD</i>
Forward	125 mm (longitudinal)
Lateral	125 mm (transversal)

6.6.5. Additional forces.

6.6.5.1. Seat inertia forces.

Except where any anchorage of the vehicle seat belt system is integrated with the vehicle seat structure, the forces applied in paragraph 6.6.4. shall be supplemented by a force equal to 20 g times the masse of the relevant part of the seat assembly for forward loading case.

- In paragraph 7.INSPECTION DURING AND AFTER STATIC TESTS, add at tend of the titre to read :

7. INSPECTION DURING AND AFTER STATIC TESTS FOR SAFETY BELT ANCHORAGES.

- In paragraph 9. CONFORMITY OF PRODUCTION, add in the following paragraphs to read :

9.1. ...with regard to details affecting the characteristics of the **safety belt anchorages and the ISOFIX anchorage systems.**

- In paragraph 10. PENALTIES FOR NON CONFORMITY OF PRODUCTION, add in the following paragraphs to read :

10.1. ...complied with or if its **safety belt anchorages or the ISOFIX anchorage systems failed to pass the checks prescribed ...**

- In paragraph 11.OPERATING INSTRUCTIONS,

- The first sentence has to be numbered as follow :

11.1. The national authorities may require...

- Renumber paragraph 11.1.. (former) as paragraph 11.1.1.
- Renumber paragraph 11.2.. (former) as paragraph 11.1.2.
- insert new paragraphs 11.2 to read :

- 11.2. The vehicle owner's handbook shall indicate :
- The different ISOFIX anchorage systems, including any restrictions on the groups of masse (as defined in Regulation 44) for ISOFIX child restraint systems that can be fitted,
 - Where applicable any restrictions on the simultaneous use of ISOFIX child restraint systems on adjacent seating positions,
 - Where applicable any restrictions on the adjustments of vehicle seats resulting from the fitting of an ISOFIX child restraint system.

➤ In paragraph 12. PRODUCTION DEFINITELY DISCONTINUED, add in the following paragraphs to read :

- 12.1. ...a type of safety belt anchorages **or a type of ISOFIX anchorage systems** approved in accordance with this Regulation...

➤ In paragraph 14. TRANSITIONAL PROVISIONS, the following sub-paragraph must be rewording as follow :

- 14.1 As from the official date of entry into force of the [05] 06 series of amendments, no contracting Party...as amended by the [05] 06 series of amendments.

- 14.2 As from [] after the date of entry into force of the [05] 06 series of amendment to this Regulation, Contracting Parties applying this Regulation shall grant ECE approvals only if the requirements of this Regulation, as amended by the [05] 06 series of amendments are satisfied.

- 14.3 As from [] after the date of entry into force of the [05] 06 series of amendment to this Regulation, Contracting Parties applying this Regulation may refuse to recognise approvals which were no granted in accordance with the [05] 06 series of amendments to this regulation.

➤ In Annex 1. COMMUNICATION, add in the following paragraphs to read :

...of a vehicle type with regard to safety belt anchorages **and ISOFIX anchorage systems if any** pursuant to...

Footnote :

...Only if the **belt anchorage and the ISOFIX anchorage systems, if any, are** affixed on the seat or if the seat supports...

19. ...drawings, diagrams and plans of the belt anchorages, **of the ISOFIX anchorage systems, if any**, and of the vehicle structure ;

20. ...photographs of the belt anchorages, **of the ISOFIX anchorage systems, if any**, and of the vehicle structure.

➤ In Annex 2. ARRANGEMENTS OF THE APPROVAL MARK,

- Replace the current reference :

[~~“14R—052439”~~] situated on the right of the first drawing of the approval mark by the following one “**14R –062439**”

- Add or replace in the following paragraphs to read :

...with regard to safety-belt anchorages **and ISOFIX anchorage systems, if any**,...

...under the number [~~052439~~] **062439**...

...already included the [~~05~~] **06** series of amendments...(two time)

- Replace the current reference [~~“14R—052439”~~] situated on the right of the second drawing of the approval mark by the following one “**14 062439**”.