



**Economic and Social
Council**

Distr.
GENERAL

TRANS/WP.29/793
2 August 2001

ENGLISH
Original: ENGLISH
and FRENCH

ECONOMIC COMMISSION FOR EUROPE

INLAND TRANSPORT COMMITTEE

World Forum for Harmonization of Vehicle Regulations (WP.29)

DRAFT SUPPLEMENT 6 TO THE 09 SERIES OF AMENDMENTS
TO REGULATION No. 13

(Braking)

Note: The text reproduced below was adopted by the Administrative Committee (AC.1) of the amended 1958 Agreement at its eighteenth session, following the recommendation by WP.29 at its one-hundred-and-twenty-fourth session. It is based on document TRANS/WP.29/2001/33, as amended (TRANS/WP.29/792, para. 132). In addition, para. 1.5.1.7. (new) was renumbered into 1.5.1.8. and some editorial improvements were made.

Paragraph 2.5., delete the words "but controlled by him".

Insert a new paragraph 2.14., to read:

"2.14. "Phased braking" is a means which may be used where two or more sources of braking are operated from a common control, whereby one source may be given priority by phasing back the other source(s) so as to make increased control movement necessary before they begin to be brought into operation.

Paragraphs 2.14. to 2.19. (former), renumber as paragraphs 2.15. to 2.20.

Paragraph 2.20. (former), should be deleted.

Paragrph 2.20.1. (former), renumber as paragraph 2.21., and amend to read:

"2.21. "Electric regenerative braking" means a braking system which, during deceleration, provides for the conversion of vehicle kinetic energy into electrical energy."

Paragraphs 2.20.2. to 2.20.6. (former), renumber as paragraphs 2.21.1. to 2.21.5.

Paragraphs 2.21. to 2.27.3. (former), renumber as paragraphs 2.22. to 2.28.3.

Insert new paragraphs 2.29. and 2.30., to read:

"2.29. "Automatically commanded braking" means a function within a complex electronic control system where actuation of the braking system(s) or brakes of certain axles is made for the purpose of generating vehicle retardation with or without a direct action of the driver, resulting from the automatic evaluation of on-board initiated information.

2.30. "Selective braking" means a function within a complex electronic control system where actuation of individual brakes is made by automatic means in which vehicle retardation is secondary to vehicle behaviour modification."

Paragraph 5.1.3.6., amend to read:

"... not delay the braking functions: the power supply, provided by the ISO 7638 connection, shall be exclusively for braking and running gear functions and that required for the transfer of trailer related information not transmitted by the electric control line, however, in all cases the provisions of paragraph 5.2.2.18. of this Regulation shall apply. The power supply for other functions shall use other measures."

Insert a new paragraph 5.1.5., to read:

"5.1.5. The requirements of annex 18 shall be applied to the safety aspects of all complex electronic vehicle control systems which provide or form part of the control transmission of the braking function included those which utilise the braking system(s) for automatically commanded braking or selective braking.

However, systems or functions, which use the braking system as the means of achieving a higher level objective, are subject to annex 18 only insofar as they have a direct effect on the braking system. If such

systems are provided, they must not be deactivated during type approval testing of the braking system."

Paragraphs 5.2.1.7. to 5.2.1.7.2., amend to read:

- "5.2.1.7. The service braking system shall act on all wheels of the vehicle and shall distribute its action appropriately among the axles.
- 5.2.1.7.1. In the case of vehicles with more than two axles, in order to avoid wheel-locking or glazing of the brake linings, the brake force on certain axles may be reduced to zero automatically when carrying a much reduced load, provided that the vehicle meets all the performance requirements prescribed in annex 4 to this Regulation.
- 5.2.1.7.2. In the case of M₁ and N₁ category vehicles with electric regenerative braking systems of category B, the braking input from other sources of braking, may be suitably phased to allow the electric regenerative braking system alone to be applied, provided that both the following conditions are met:"

Insert a new paragraphs 5.2.1.7.2.1. and 5.2.1.7.2.2., including their corresponding footnote *//, to read:

- "5.2.1.7.2.1. Intrinsic variations in the torque output of the electrical regenerative braking system (e.g. as a result of changes in the electric state of charge in the traction batteries) are automatically compensated by appropriate variation in the phasing relationship as long as the requirements *// of one of the following annexes to this Regulation are satisfied:
- Annex 4, paragraph 1.3.2., or
Annex 13 paragraph 5.3. (including the case with the electric motor engaged), and
- 5.2.1.7.2.2. Wherever necessary, to ensure that braking rate *// remains related to the driver's braking demand, having regard to the available tyre/road adhesion, braking shall automatically be caused to act on all wheels of the vehicle.

*// The Authority, which is to grant approval, shall have the right to check the service braking system by additional vehicle test procedures."

Paragraph 5.2.1.8., amend to read (footnote 5/ should be deleted):

- "5.2.1.8. The action of the service braking system shall be distributed between the wheels of one and the same axle symmetrically in relation to the longitudinal median plane of the vehicle. Compensation and functions, such as anti-lock, which may cause deviations from this symmetrical distribution, shall be declared."

Paragraph 5.2.1.10., amend to read:

"5.2.1.10. The service, secondary and parking braking systems must act on braking surfaces connected to the wheels through components of adequate strength.

Where braking torque for a particular axle or axles is provided by both a friction braking system and an electrical regenerative braking system of category B, disconnection of the latter source is permitted, providing that the friction braking source remains permanently connected and able to provide the compensation referred to in paragraph 5.2.1.7.2.1.

However in the case of short disconnection transients, incomplete compensation is accepted, but within 1 s, this compensation shall have attained at least 75 per cent of its final value.

Nevertheless, in all cases the permanently connected friction braking source shall ensure that both the service and secondary braking systems continue to operate with the prescribed degree of effectiveness.

Disconnection of the braking surfaces of the parking braking system shall be permitted only on condition that the disconnection is controlled exclusively by the driver from his driving seat, by a system incapable of being brought into action by a leak."

Paragraph 5.2.1.21., amend to read:

"for the purpose of vehicle stabilization."

Paragraph 5.2.1.25., amend to read:

"5.2.1.25. Additional requirements for vehicles of categories M_1 , M_2 , N_1 and category $N_2 < 5$ tonnes equipped with an electric regenerative braking system."

Paragraph 5.2.1.25.1., amend to read:

"5.2.1.25.1. Vehicles fitted with an electric regenerative braking system of category A."

Paragraph 5.2.1.25.2., amend to read:

"5.2.1.25.2. Vehicles fitted with an electric regenerative braking system of category B."

Paragraph 5.2.1.25.2.1., amend to read:

"5.2.1.25.2.1. It shall not be possible to disconnect, partially or totally, one part of the service braking system other than by automatic means. This should not be construed as a departure from the requirements of paragraph 5.2.1.10."

Paragraph 5.2.1.25.2.3., amend to read:

"5.2.1.25.2.3. For vehicles fitted with an electric regenerative braking system of both categories"

Paragraph 5.2.2.5., amend to read (footnote 7/ should be deleted):

5.2.2.5. The action of the service braking system shall be distributed between the wheels of one and the same axle symmetrically in relation to the longitudinal median plane of the vehicle. Compensation and functions, such as anti-lock, which may cause deviations from this symmetrical distribution, shall be declared.

Paragraph 5.2.2.14., amend to read:

"5.2.2.14. Where the auxiliary equipment is supplied with energy from the service braking system, the service braking system shall be protected to ensure that the sum of the braking forces exerted at the periphery of the wheels shall be at least 80 percent of the value prescribed for the relevant trailer as defined in paragraph 3.1.2.1. of annex 4 to this Regulation. This requirement shall be fulfilled under both of the following operating conditions:

During operation of the auxiliary equipment; and

In the event of breakage or leakage from the auxiliary equipment, unless such breakage or leakage affects the control signal referred to in paragraph 6. to annex 10 to this Regulation, in which case the performance requirements of that paragraph shall apply."

Paragraph 5.2.2.14.1., amend to read:

"5.2.2.14.1. The above provisions are deemed to be fulfilled when the pressure in the service brake storage device(s) is maintained at a pressure of at least 80 percent of the control line demand pressure or equivalent digital demand as defined in paragraph 3.1.2.2. of annex 4 to this Regulation."

Annex 2,

Insert a new item 14.13., to read:

"14.13. Adequate documentation according to annex 18 was supplied in respect of the following system(s):
.....
..... Yes / No / Not applicable 2/

Annex 4,

Paragraph 1.2.8., amend to read:

"1.2.8. For vehicles powered completely or partially by an electric motor (or motors), permanently connected to the wheels, all tests must be carried out with the motor(s) connected."

Paragraph 1.2.9., amend to read:

"1.2.9. For vehicles as described in paragraph 1.2.8. above, fitted with an electric regenerative braking system"

Insert a new paragraph 1.2.11., to read:

"1.2.11. For a vehicle with electrically actuated service brakes powered from traction batteries (or an auxiliary battery) which receive(s) energy only from an independent external charging system, these batteries shall, during braking performance testing, be at an average of not more than 5 per cent above that state of charge at which the brake failure warning prescribed in paragraph 5.2.1.27.6. is required to be given.

If this warning is given, the batteries may receive some recharge during the tests, to keep them in the required state of charge range."

Paragraph 1.3.2., amend to read:

"..... and O_4 on a road on which adhesion is reduced, must meet the relevant requirements of annex 10 and/or annex 13 to this Regulation."

Insert a new paragraph 1.3.2.1. (including a new footnote 2/) to read:

"1.3.2.1. In the case of a braking system according to paragraph 5.2.1.7.2., where the braking for a particular axle (or axles) is comprised of more than one source of braking torque, and any individual source can be varied with respect to the other(s), the vehicle shall satisfy the requirements of annex 10, or alternatively, annex 13 under all relationships permitted by its control strategy. 2/

2/ The manufacturer shall provide the Technical Service with the family of braking curves permitted by the automatic control strategy employed. These curves may be verified by the Technical Service."

Paragraph 1.4.1.2.2., amend to read (including the addition of a new footnote 3/):

"... in annex 2 of this Regulation

In the case of a vehicle equipped with an electric regenerative braking system, the requirements depend on the category of this system:

Category A. Any separate electric regenerative braking control which is provided, shall not be used during the Type-0 tests.

Category B. The contribution of the electric regenerative braking system to the braking force generated shall not exceed that minimum level guaranteed by the system design.

This requirement is deemed to be satisfied if the batteries are at one of the following state of charge conditions where state of charge 3/ is determined by the method set out in appendix 1 to this annex:

at the maximum charge level as recommended by the manufacturer in the vehicle specification, or

at a level not less than 95 per cent of the full charge level, where the manufacturer has made no specific recommendation, or

at the maximum level which results from automatic charge control on the vehicle.

3/ By agreement with the technical service, state of charge assessment will not be required for vehicles, which have an on-board energy source for charging the traction batteries and the means for regulating their state of charge."

Paragraph 1.5.1.6., amend to read:

"1.5.1.6. For vehicles not having sufficient autonomy to carry out the cycles of heating of the brakes, the tests shall be carried out by achieving the prescribed speed before the first braking application and thereafter by using the maximum acceleration available to regain speed and then braking successively at the speed reached at the end of each time cycle duration as specified, for the appropriate vehicle category, in paragraph 1.5.1.1. above."

Insert a new paragraph 1.5.1.8., to read:

"1.5.1.8. For vehicles equipped with an electric regenerative braking system of category B, the condition of the vehicle batteries at the start of the test, shall be such that the braking force contribution provided by the electric regenerative braking system does not exceed the minimum guaranteed by the system design.

This requirement is deemed to be satisfied if the batteries are at one of the state of charge conditions listed in the fourth clause of paragraph 1.4.1.2.2. above."

Paragraph 1.5.3.1.2., amend to read:

"1.5.3.1.2. For vehicles fitted with an electric regenerative braking system"

Insert a new paragraph 1.5.3.1.3., to read:

"1.5.3.1.3. In the case of vehicles equipped with an electric regenerative braking system of category B, having carried out the heating cycles according to paragraph 1.5.1.6. of this annex, the hot performance test shall be carried out at the maximum speed which can be reached by the vehicle at the end of the brake heating cycles, unless the speed specified in paragraph 1.4.2. of this annex can be reached.

For comparison, the Type-0 test with cold brakes shall be repeated from this same speed and with a similar electric regenerative braking contribution, as set by an appropriate state of battery charge, as was available during the hot performance test.

Reconditioning of the linings shall be permitted before the test is made to compare this second Type-0 cold performance with that achieved in the hot test, against the criteria of paragraphs 1.5.3.1.1. and 1.5.3.2. of this annex."

Paragraph 1.5.3.1.3. (former), renumber as paragraph 1.5.3.1.4.

Paragraph 1.5.3.3., should be deleted.

Paragraphs 2.2.6. to 2.2.6.2., amend to read:

- "2.2.6. For vehicles employing electric regenerative braking systems, the braking performance shall additionally be checked under the two following failure conditions:
- 2.2.6.1. For a total failure of the electric component of the service braking output.
- 2.2.6.2. In the case where the failure condition causes the electric component to deliver its maximum braking force."

Insert a new appendix 1 to annex 4, to read:

"Annex 4 - Appendix 1

PROCEDURE FOR MONITORING THE STATE OF BATTERY CHARGE.

This procedure is applicable to vehicle batteries used for traction and regenerative braking.

The procedure requires the use of a bi-directional DC Watt-hour meter.

1. Procedure.
 - 1.1. If the batteries are new or have been subject to extended storage, they shall be cycled as recommended by the manufacturer. A minimum 8 hour soak period at ambient temperature shall be allowed after completion of cycling.
 - 1.2. A full charge shall be established using the manufacturer's recommended charging procedure.
 - 1.3. When the braking tests of paragraphs 1.2.11., 1.4.1.2.2., 1.5.1.6., and 1.5.3.1.3. of annex 4 are conducted the watt-hours consumed by the traction motors and supplied by the regenerative braking system shall be recorded as a running total which shall then be used to determine the state of charge existing at the beginning or end of a particular test.

- 1.4. To replicate a level of state of charge in the batteries for comparative tests, such as those of paragraph 1.5.3.1.3., the batteries shall be either recharged to that level or charged to above that level and discharged into a fixed load at approximately constant power until the required state of charge is reached. Alternatively, for vehicles with battery powered electric traction only, the state of charge may be adjusted by running the vehicle. Tests conducted with a battery partially charged at their start shall be commenced as soon as possible after the desired state of charge has been reached."

Annex 5, amend to read:

"Annex 5

ADDITIONAL PROVISIONS APPLICABLE TO CERTAIN VEHICLES
AS SPECIFIED IN THE ADR

1. SCOPE

This Annex applies to certain vehicles for which the European Agreement concerning the International Carriage of Dangerous Goods by Road (ADR) contains specific requirements as concerns anti-lock and endurance braking performance.

2. REQUIREMENTS

2.1. General provisions

Power-driven vehicles and trailers intended for use as transport units for dangerous goods shall fulfil all relevant technical requirements of this Regulation. In addition, the following technical provisions shall apply as appropriate.

2.2. Anti-lock braking system of trailers

- 2.2.1. Trailers of category O₄ shall be equipped with category A anti-lock systems as defined in annex 13 of this Regulation.

2.3. Endurance braking system

- 2.3.1. Power-driven vehicles having a maximum mass exceeding 16 tonnes, or authorized to tow a trailer of category O₄ shall be fitted with an endurance braking system according to paragraph 2.14. of this Regulation which complies with the following requirements:
- 2.3.1.1. The endurance braking control configurations shall be from a type described in paragraphs 2.14.2.1. to 2.14.2.3. of this Regulation.
- 2.3.1.2. In the case of an electrical failure of the anti-lock system, integrated or combined endurance braking systems shall be switched off automatically.

- 2.3.1.3. The effectiveness of the endurance braking system shall be controlled by the anti-lock braking system such that the axle(s) braked by the endurance braking system cannot be locked by that system at speeds above 15 km/h. However, this requirement shall not apply to that part of the braking system constituted by the natural engine braking.
- 2.3.1.4. The endurance braking system shall comprise several stages of effectiveness, including a low stage appropriate for the unladen condition. Where the endurance braking system of a power-driven vehicle is constituted by its engine, the different gear ratios shall be considered to provide the different stages of effectiveness.
- 2.3.1.5. The performance of the endurance braking system must be such that it fulfils the requirements of paragraph 1.8. of annex 4 to this Regulation (Type-II A test), with a laden vehicle mass comprising the laden mass of the motor vehicle and its authorized maximum towed mass but not exceeding a total of 44 tonnes.
- 2.3.2. If a trailer is equipped with an endurance braking system it shall fulfil the requirements of paragraphs 2.3.1.1. to 2.3.1.4. above as appropriate."

Annex 10,

Paragraph 3.1.4.5., amend to read:

"3.1.4.5. For vehicles fitted with an electric regenerative braking
....."

Annex 12,

Paragraph 2.2.18., amend the reference to "paragraph 9.4.1.", to read "paragraph 9.4."

Insert new paragraphs 2.2.19.1. and 2.2.19.2., to read:

"2.2.19.1. s_{Hz} : stroke of master cylinder in millimetres according to figure 8;

2.2.19.2. s''_{Hz} : spare travel of master cylinder in millimetres at piston rod according to figure 8;"

Paragraphs 2.2.23. and 2.2.23.1., amend to read:

"2.2.23. M^* : Braking torque as specified by the manufacturer according to paragraph 5. of appendix 3. This braking torque shall produce a braking force of at least the prescribed braking force B^* ;

2.2.23.1. M_T : Test braking torque in the case when no overload protector is fitted (according to paragraph 6.2.1.);"

Insert new paragraphs 2.2.26. to 2.2.28., to read:

"2.2.26. M_r : Maximum braking torque up to the maximum permissible travel s_r or up to the maximum permissible fluid volume V_r when the trailer moves rearward (including rolling resistance = $0.01 \cdot g \cdot G_{B0}$);

- 2.2.27. s_r : Maximum permissible travel at brake control lever when the trailer moves rearward;
- 2.2.28. V_r : Maximum permissible fluid volume absorption of one braking wheel when the trailer moves rearward;"

Paragraphs 2.3.5. and 2.3.6., amend to read:

- "2.3.5. P : force applied to brake control lever; (see Figure 4 of appendix 1 to this annex);
- 2.3.6. P_o : Brake-retraction force when the trailer moves forward; i.e., in graph $M = f(P)$, the value of the force P at the point of intersection of the extrapolation of this function with the abscissa (see Figure 6 of appendix 1 to this annex);"

Insert a new paragraph 2.3.6.1., to read:

- "2.3.6.1. P_{or} : brake-retraction force when the trailer moves rearward (see Figure 6 of appendix 1 to this annex);"

Paragraph 2.3.7., amend to read:

- "2.3.7. P^* : Force applied to brake control lever to produce the braking force B^* ;"

Insert new paragraphs 2.3.8. to 2.3.9.1., to read:

- "2.3.8. P_T : test force according to paragraph 6.2.1.;
- 2.3.9. ρ : characteristic of brake when the trailer moves forward as defined by:
- $$M = \rho (P - P_o)$$
- 2.3.9.1. ρ_r : characteristic of brake when the trailer moves rearward as defined by:
- $$M_r = \rho_r (P_r - P_{or})"$$

Paragraph 2.4.6., amend to read:

- "2.4.6. p_o : retraction pressure in brake cylinder when the trailer moves forward; i.e., in graph $M = f(p)$, the value of the pressure p at the point of intersection of the extrapolation of this function with the abscissa (see Figure 7 of appendix 1 to this annex);"

Insert a new paragraph 2.4.6.1., to read:

- "2.4.6.1. p_{or} : brake retraction pressure when the trailer moves rearward (see Figure 7 of appendix 1 to this annex);"

Paragraph 2.4.7., amend to read:

"2.4.7. p^* : Hydraulic pressure in brake cylinder to produce the braking force B^* ;"

Insert new paragraphs 2.4.8. to 2.5.9., to read:

"2.4.8. p_T : Test pressure according to paragraph 6.2.1.:"

2.4.9. ρ' : characteristic of brake when the trailer moves forward as defined by:

$$M = \rho' (p - p_o)$$

2.4.9.1. ρ'_r : characteristic of brake when the trailer moves rearward as defined by:

$$M_r = \rho'_r (p_r - p_{or})$$

2.5. Symbols with respect to the braking requirements relating to overload protectors

2.5.1. D_{op} : Application force at input side of the control device, at which the overload protector is activated

2.5.2. M_{op} : Brake torque at which the overload protector is activated (as declared by the manufacturer)

2.5.3. M_{Top} : Minimum test braking torque in the case when an overload protector is fitted (according to paragraph 6.2.2.2.)

2.5.4. P_{op_min} : Force applied to the brake at which the overload protector is activated (according to paragraph 6.2.2.1.)

2.5.5. P_{op_max} : Maximum force (when the coupling head is pushed fully home) which is applied by the overload protector to the brake (according to paragraph 6.2.2.3.)

2.5.6. P_{op_min} : Pressure applied to the brake at which the overload protector is activated (according to paragraph 6.2.2.1.)

2.5.7. P_{op_max} : Maximum hydraulic pressure (when the coupling head is pushed fully home) which is applied by the overload protector to the brake actuator (according to paragraph 6.2.2.3.)

2.5.8. P_{Top} : Minimum test brake force in the case when an overload protector is fitted (according to paragraph 6.2.2.2.)

2.5.9. p_{Top} : Minimum test brake pressure in the case when an overload protector is fitted (according to paragraph 6.2.2.2.)"

Paragraph 3.6., amend to read:

- "3.6. Inertia braking systems may incorporate overload protectors. They may not be activated at a force of less than $D_{op} = 1.2 \cdot D^*$ (when fitted at the control device) or at a force of less than $P_{op} = 1.2 \cdot P^*$ or at a pressure of less than $p_{op} = 1.2 \cdot p^*$ (when fitted at the wheel brake) whereas the force P^* or the pressure p^* corresponds to a braking force of $B^* = 0,5 \cdot g \cdot G_{Bo}$."

Insert new paragraphs 5.4.4. to 5.4.6., to read:

- "5.4.4. surface area of piston in master cylinder F_{Hz} , as referred to in paragraph 2.2.4. of this annex.
- 5.4.5. stroke of master cylinder s_{Hz} , measured in millimetres, as referred to in paragraph 2.2.19.1. of this annex.
- 5.4.6. spare travel of master cylinder s''_{Hz} , measured in millimetres, as referred to in paragraph 2.2.19.2. of this annex."

Paragraph 6.1, amend to read:

- "6.1. In addition to the brakes to be checked, the manufacturer shall submit to the Technical Service conducting the tests drawings of the brakes showing the type, dimensions and material of the essential components and the make and type of the linings. In the case of hydraulic brakes, these drawings shall show the surface area F_{RZ} of the brake cylinders. The manufacturer shall also specify the braking torque M^* and the mass G_{Bo} referred to in paragraph 2.2.4. of this annex."

Paragraphs 6.2. to 6.2.2.2., amend to read:

- "6.2. Testing conditions
- 6.2.1. In the case when an overload protector is neither be fitted nor intended to be fitted within the inertia (overrun) braking system, the wheel brake shall be tested with the following test forces or pressures:
- $P_T = 1.8 P^*$ or $p_T = 1.8 p^*$ and $M_T = 1.8 M^*$ respectively.
- 6.2.2. In the case when an overload protector is fitted or intended to be fitted within the inertia (overrun) braking system, the wheel brake shall be tested with the following test forces or pressures:
- 6.2.2.1. The minimum design values for overload protector shall be specified by the manufacturer and shall not be less than
- $P_{op} = 1.2 P^*$ or $p_{op} = 1.2 p^*$

6.2.2.2. The minimum test force P_{Top} or the minimum test pressure p_{Top} and the minimum test torque M_{Top} are:

$$P_{Top} = 1.1 \cdot 1.2 P^* \text{ or } p_{Top} = 1.1 \cdot 1.2 p^* ,$$

$$\text{and } M_{Top} = 1.1 \cdot 1.2 M^*$$

Insert a new paragraph 6.2.2.3., to read:

"6.2.2.3. The maximum values (P_{op_max} or p_{o_pmax}) for the overload protector shall be specified by the manufacturer and shall not be more than P_T or p_T ."

Paragraphs 7.2.3. to 7.2.3.2., should be deleted.

Insert new paragraphs 7.3. to 7.5., to read:

"7.3. In the case of mechanical brakes, the following should be determined:

7.3.1. reduction ratio i_g (see Figure 4 of appendix 1 to this annex)

7.3.2. Force P^* for M^*

7.3.3. The braking torque M^* as a function of the force P^* applied to the control lever in mechanical-transmission systems. The rotational speed of the braking surfaces shall correspond to an initial vehicle speed of 60 km/h when the trailer moves forward and 6 km/h when the trailer moves rearward. The following shall be derived from the curve obtained from these measurements (see Figure 6 of appendix 1 to this annex):

7.3.3.1. The brake-retraction force P_o and the characteristic value ρ when the trailer moves forward

7.3.3.2. The brake-retraction force P_{or} and the characteristic value ρ_r when the trailer moves rearward

7.3.3.3. Maximum braking torque M_r up to the maximum permissible travel s_r when the trailer moves rearward (see Figure 6 of appendix 1 to this annex)

7.3.3.4. Maximum permissible travel at brake control lever when the trailer moves rearward (see Figure 6 of appendix 1 to this annex)

7.4. In the case of hydraulic brakes, the following should be determined:

7.4.1. Reduction ratio i_g' (see Figure 8 of appendix 1 to this annex)

7.4.2. Pressure p^* for M^*

- 7.4.3. The braking torque M^* as a function of the pressure p^* applied to the control lever in mechanical-transmission systems. The rotational speed of the braking surfaces shall correspond to an initial vehicle speed of 60 km/h when the trailer moves forward and 6 km/h when the trailer moves rearward. The following shall be derived from the curve obtained from these measurements (see Figure 7 of appendix 1 to this annex):
- 7.4.3.1. The retraction pressure p_o and the characteristic ρ' when the trailer moves forward
- 7.4.3.2. The retraction pressure p_{or} and the characteristic ρ_r , when the trailer moves rearward
- 7.4.3.3. Maximum braking torque M_r up to the maximum permissible fluid volume V_r when the trailer moves rearward (see Figure 7 of appendix 1 to this annex)
- 7.4.3.4. Maximum permissible fluid volume absorption V_x of one braking wheel when the trailer moves rearward (see figure 7 of appendix 1).
- 7.4.4. Surface area of piston in brake cylinder F_{RZ} .
- 7.5. Alternative Procedure for Type-I test
- 7.5.1. The Type-I test according to annex 4, paragraph 1.5. has not to be carried out on a vehicle submitted for type approval if the braking system components are tested on an inertia test bench to meet the prescriptions of annex 4, paragraphs 1.5.2. and 1.5.3.
- 7.5.2. The alternative procedure for the Type-I test shall be carried out in accordance to the provisions laid down in annex 11, appendix 2, paragraph 3.5.2. (in analogy also applicable for disc brakes)."

Paragraph 9.4.2., amend to read:

- "9.4.2. The effective (useful) travel of control s' shall be determined for single and multi-axle trailers as follows:"

Annex 12, appendix 1, figures 6,7 and 8, amend to read:

"

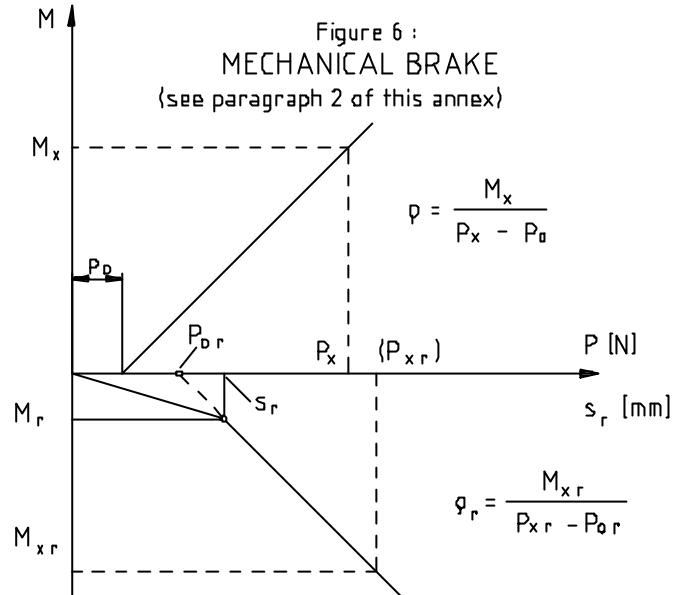
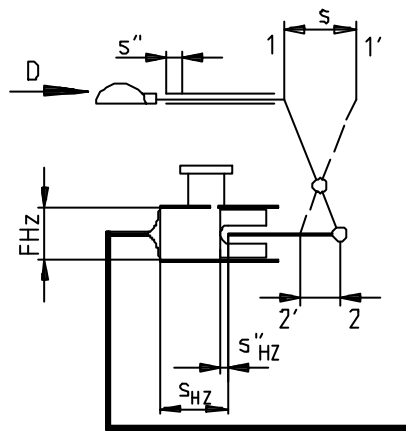

Figure 8: HYDRAULIC-TRANSMISSION BRAKING SYSTEM

(see paragraph 2 of this annex)

1.2 Control device



$$i_h = \frac{1 - 1'}{2 - 2'}$$

1.4 Brakes

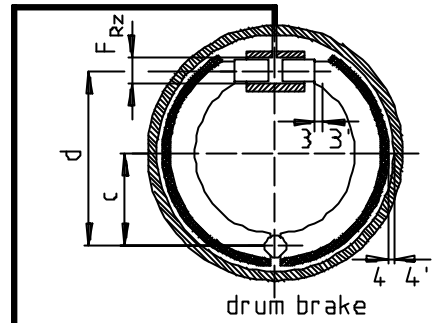

drum brake

$$i_g = \frac{d}{c} = \frac{3 - 3'}{4 - 4'}$$

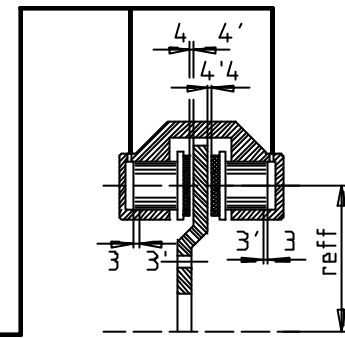

disc brake

$$i_g = \frac{r_{eff}}{r_{eff}} = \frac{3 - 3'}{4 - 4'} = 1$$

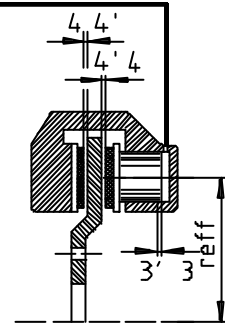

disc brake

$$i_g = \frac{r_{eff}}{r_{eff}} = \frac{3 - 3'}{2 \cdot (4 - 4')} = 1$$

Annex 12, appendix 2,

Item 8.2., amend to read:

8.2.1. with hydraulic transmission device 1/ $i_h = \text{from } \dots\dots\dots \text{ to } \dots\dots\dots \underline{2/}$ $F_{HZ} = \dots\dots\dots \text{ cm}^2$ travel of master cylinder S_{HZ} " $\dots\dots\dots \text{ mm}$ spare travel of master cylinder s_{HZ} " $\dots\dots\dots \text{ mm}''$ Item 9.6., amend to read:

"9.6. Loss of travel and spare travel:

where the position of the drawing device
has an effect $s_o \underline{1/} = \dots\dots\dots \text{ mm}$

with a hydraulic-transmission device
 $s'' \underline{1/} = s_{HZ} \cdot i_h = \dots\dots\dots \text{ mm}''$

Annex 12, appendix 3,Items 4. and 5., amend to read:"4. Permissible 'maximum mass' per wheel $G_{B0} = \dots\dots\dots \text{ kg}$ 5. Braking torque M^* (as specified by the manufacturer according to paragraph 2.2.23. of this annex) = $\dots\dots\dots \text{ Nm}''$ Item 5.1., should be deletedItem 9.4.A., amend to read:"9.4.A Retraction pressure
 $p_o = \dots\dots\dots \text{ N/cm}^2''$ Item 9.7., amend to read:"9.7. Force for M^*
 $P^* = \dots\dots\dots \text{ N}''$ Item 9.7.A., amend to read:"9.7.A. Pressure for M^*
 $P^* = \dots\dots\dots \text{ N/cm}^2''$

Item 9.8.A., amend to read:

"9.8.A. Surface area of wheel cylinder
 $F_{RZ} = \dots\dots\dots \text{cm}^2$ "

Item 9.9.A., amend "cm²" to read "cm³"

Insert new items 9.10., 9.11. and 9.12.2., to read:

"9.10.1. Service brake performance when reversing (see figures 6 and 7 of appendix 1 to this annex)

9.10.1. Maximum braking torque $M_x = \dots\dots\dots \text{Nm}$

9.10.1.A. Maximum braking torque $M_x = \dots\dots\dots \text{Nm}$

9.10.2. Maximum permissible travel $s_x = \dots\dots\dots \text{mm}$

9.10.2.A. Maximum permissible fluid volume absorption $V_x = \dots\dots\dots \text{cm}^3$

9.11. Further brake characteristics when reversing (see figures 6 and 7 of appendix 1 to this annex)

9.11.1. Brake-retraction force $P_{or} = \dots\dots\dots \text{N}$

9.11.1.A. Brake-retraction pressure $p_{or} = \dots\dots\dots \text{N/cm}^2$

9.11.2. Brake characteristic $\rho_x = \dots\dots\dots \text{m}$

9.11.2.A. Brake characteristic $\rho'_x = \dots\dots\dots \text{m}$

9.12. Tests as to paragraph 7.5. of this annex (if applicable)(corrected to take account of the rolling resistance corresponding to $0.01 \cdot g \cdot G_{Bo}$)

9.12.1. Brake test Type 0

Test speed = $\dots\dots\dots \text{km/h}$

Braking ratio = $\dots\dots\dots \%$

Control force = $\dots\dots\dots \text{N}$

9.12.2. Brake test Type I

Test speed = $\dots\dots\dots \text{km/h}$

Sustained braking ratio = $\dots\dots\dots \%$

Braking time = $\dots\dots\dots \text{min}$

Hot performance = $\dots\dots\dots \%$

(corresponding to $\dots\dots\dots \%$ of brake test Type-0 - see para. 9.12.1 above)

Control force = $\dots\dots\dots \text{N}$ "

Annex 12, appendix 4,

Insert new items 5.7.5. and 5.7.6., to read:

- "5.7.5. Ratio $s'/i_H = \dots\dots\dots$
when the trailer moves rearward (shall not exceed s_r)
- 5.7.6. Braking torque when the trailer moves rearward including rolling resistance
 $0.08 \cdot g \cdot G_A \cdot R = \dots\dots\dots$ Nm (shall
not exceed $n \cdot M_r$)"

Insert new items 5.8.5. and 5.8.6., to read:

- "5.8.5. Ratio $s'/F_{HZ} = \dots\dots\dots$
when the trailer moves rearward (shall not exceed V_r)
- 5.8.6. Braking torque when the trailer moves rearward including rolling resistance
 $0.08 \cdot g \cdot G_A \cdot R = \dots\dots\dots$ Nm (shall
not exceed $n \cdot M_r$)"

Annex 13,

Paragraph 4.1., footnote 12/, amend to read:

"12/ The manufacturer shall provide the Technical Service with documentation relating to the controller(s) which follows the format set out in annex 18."

Paragraphs 4.1.1. and 4.1.2., including its corresponding footnote 15/, amend to read:

- "4.1.1. Sensor anomalies, which cannot be detected under static conditions, shall be detected not later than when the vehicle speed exceed 10 km/h. 15/ However, to prevent erroneous fault indication when a sensor is not generating a vehicle speed output, due to non-rotation of a wheel, verification may be delayed but detected not later than when the vehicle speed exceeds 15 km/h.
- 4.1.2. When the anti-lock braking system is energized with the vehicle stationary, electrically controlled pneumatic modulator valve(s) shall cycle at least once.

15/ The warning signal may light up again while the vehicle is stationary, provided that it is extinguished before the vehicle speed reaches 10 km/h or 15 km/h, as appropriate, when no defect is present."

Paragraph 5.2.5., amend by the addition of a new footnote 16/ to read:

"5.2.5. The condition $\alpha \geq 0.75$ shall be checked with the vehicle both laden and unladen. 16/ The laden test

16/ Until a uniform test procedure is established, the tests required by this paragraph may have to be repeated for vehicles equipped with electrical regenerative braking systems, in order to determine the effect of different braking distribution values provided by automatic functions on the vehicle."

Paragraph 5.3.7., amend by the addition of a reference to the new footnote 16/, to read:

"5.3.7. During the tests provided and during these tests no part of the (outer) tyres must cross this boundary. 16/"

Insert a new annex 18, to read:

"Annex 18

SPECIAL REQUIREMENTS TO BE APPLIED TO THE SAFETY ASPECTS OF COMPLEX ELECTRONIC VEHICLE CONTROL SYSTEMS

1. GENERAL

This annex defines the special requirements for documentation, fault strategy and verification with respect to the safety aspects of complex electronic vehicle control systems (paragraph 2.3. below) as far as this Regulation is concerned.

This annex may also be called, by special paragraphs in this Regulation, for safety related functions which are controlled by electronic system(s).

This annex does not specify the performance criteria for "The System" but covers the methodology applied to the design process and the information which must be disclosed to the technical service, for type approval purposes.

This information shall show that "The System" respects, under normal and fault conditions, all the appropriate performance requirements specified elsewhere in this Regulation.

2. DEFINITIONS

For the purposes of this annex,

2.1. "Safety concept" is a description of the measures designed into the system, for example within the electronic units, so as to address system integrity and thereby ensure safe operation even in the event of an electrical failure.

The possibility of a fall-back to partial operation or even to a back-up system for vital vehicle functions may be a part of the safety concept.

- 2.2. "Electronic control system" means a combination of units, designed to co-operate in the production of the stated vehicle control function by electronic data processing.

Such systems, often controlled by software, are built from discrete functional components such as sensors, electronic control units and actuators and connected by transmission links. They may include mechanical, electro-pneumatic or electro-hydraulic elements.

"The System", referred to herein, is the one for which type approval is being sought.

- 2.3. "Complex electronic vehicle control systems" are those electronic control systems which are subject to a hierarchy of control in which a controlled function may be over-ridden by a higher level electronic control system/function.

A function which is over-ridden becomes part of the complex system.

- 2.4. "Higher-level control" systems/functions are those which employ additional processing and/or sensing provisions to modify vehicle behaviour by commanding variations in the normal function(s) of the vehicle control system.

This allows complex systems to automatically change their objectives with a priority which depends on the sensed circumstances.

- 2.5. "Units" are the smallest divisions of system components which will be considered in this annex, since these combinations of components will be treated as single entities for purposes of identification, analysis or replacement.

- 2.6. "Transmission links" are the means used for inter-connecting distributed units for the purpose of conveying signals, operating data or an energy supply.

This equipment is generally electrical but may, in some part, be mechanical, pneumatic or hydraulic.

- 2.7. "Range of control" refers to an output variable and defines the range over which the system is likely to exercise control.

- 2.8. "Boundary of functional operation" defines the boundaries of the external physical limits within which the system is able to maintain control.

3. DOCUMENTATION

3.1. Requirements

The manufacturer shall provide a documentation package which gives access to the basic design of "The System" and the means by which it is linked to other vehicle systems or by which it directly controls output variables.

The function(s) of "The System" and the safety concept, as laid down by the manufacturer, shall be explained.

Documentation shall be brief, yet provide evidence that the design and development has had the benefit of expertise from all the system fields which are involved.

For periodic technical inspections, the documentation shall describe how the current operational status of "The System" can be checked.

3.1.1. Documentation shall be made available in two parts:

(a) The formal documentation package for the approval, containing the material listed in paragraph 3 (with the exception of that of paragraph 3.4.4.) which shall be supplied to the technical service at the time of submission of the type approval application. This will be taken as the basic reference for the verification process set out in paragraph 4. of this annex.

(b) Additional material and analysis data of paragraph 3.4.4., which shall be retained by the manufacturer, but made open for inspection at the time of type approval.

3.2. Description of the functions of "The System"

A description shall be provided which gives a simple explanation of all the control functions of "The System" and the methods employed to achieve the objectives, including a statement of the mechanism(s) by which control is exercised.

3.2.1. A list of all input and sensed variables shall be provided and the working range of these defined.

3.2.2. A list of all output variables which are controlled by "The System" shall be provided and an indication given, in each case, of whether the control is direct or via another vehicle system. The range of control (paragraph 2.7.) exercised on each such variable shall be defined.

3.2.3. Limits defining the boundaries of functional operation (paragraph 2.8.) shall be stated where appropriate to system performance.

3.3. System layout and schematics

3.3.1. Inventory of components

A list shall be provided, collating all the units of "The System" and mentioning the other vehicle systems which are needed to achieve the control function in question.

An outline schematic showing these units in combination, shall be provided with both the equipment distribution and the interconnections made clear.

3.3.2. Functions of the units

The function of each unit of "The System" shall be outlined and the signals linking it with other units or with other vehicle systems shall be shown. This may be provided by a labelled block diagram or other schematic, or by a description aided by such a diagram.

3.3.3. Interconnections

Interconnections within "The System" shall be shown by a circuit diagram for the electric transmission links, by a piping diagram for pneumatic or hydraulic transmission equipment and by a simplified diagrammatic layout for mechanical linkages.

3.3.4. Signal flow and priorities

There shall be a clear correspondence between these transmission links and the signals carried between Units.

Priorities of signals on multiplexed data paths shall be stated, wherever priority may be an issue affecting performance or safety as far as this Regulation is concerned.

3.3.5. Identification of units

Each unit shall be clearly and unambiguously identifiable (e.g. by marking for hardware and marking or software output for software content) to provide corresponding hardware and documentation association.

Where functions are combined within a single unit or indeed within a single computer, but shown in multiple blocks in the block diagram for clarity and ease of explanation, only a single hardware identification marking shall be used.

The manufacturer shall, by the use of this identification, affirm that the equipment supplied conforms to the corresponding document.

3.3.5.1. The identification defines the hardware and software version and, where the latter changes such as to alter the function of the Unit as far as this Regulation is concerned, this identification shall also be changed.

3.4. Safety concept of the manufacturer

3.4.1. The manufacturer shall provide a statement which affirms that the strategy chosen to achieve "The System" objectives will not, under non-fault conditions, prejudice the safe operation of systems which are subject to the prescriptions of this Regulation.

3.4.2. In respect of software employed in "The System", the outline architecture shall be explained and the design methods and tools used shall be identified. The manufacturer shall be prepared, if required, to show some evidence of the means by which they determined the realisation of the system logic, during the design and development process.

3.4.3. The Manufacturer shall provide the technical authorities with an explanation of the design provisions built into "The System" so as to

generate safe operation under fault conditions. Possible design provisions for failure in 'The System' are for example:

- (a) Fall-back to operation using a partial system.
- (b) Change-over to a separate back-up system.
- (c) Removal of the high level function.

In case of a failure, the driver shall be warned for example by warning signal or message display. When the system is not deactivated by the driver, eg. by turning the ignition (run) switch to "off", or by switching off that particular function if a special switch is provided for that purpose, the warning shall be present as long as the fault condition persists.

- 3.4.3.1. If the chosen provision selects a partial performance mode of operation under certain fault conditions, then these conditions shall be stated and the resulting limits of effectiveness defined.
- 3.4.3.2. If the chosen provision selects a second (back-up) means to realise the vehicle control system objective, the principles of the change-over mechanism, the logic and level of redundancy and any built in back-up checking features shall be explained and the resulting limits of back-up effectiveness defined.
- 3.4.3.3. If the chosen provision selects the removal of the Higher Level Function, all the corresponding output control signals associated with this function shall be inhibited, and in such a manner as to limit the transition disturbance.
- 3.4.4. The documentation shall be supported, by an analysis which shows, in overall terms, how the system will behave on the occurrence of any one of those specified faults which will have a bearing on vehicle control performance or safety.

This may be based on a Failure Mode and Effect Analysis (FMEA), a Fault Tree Analysis (FTA) or any similar process appropriate to system safety considerations.

The chosen analytical approach(es) shall be established and maintained by the Manufacturer and shall be made open for inspection by the technical service at the time of the type approval.

- 3.4.4.1. This documentation shall itemise the parameters being monitored and shall set out, for each fault condition of the type defined in paragraph 3.4.4. above, the warning signal to be given to the driver and/or to service/technical inspection personnel.

4. VERIFICATION AND TEST

- 4.1. The functional operation of "The System", as laid out in the documents required in paragraph 3., shall be tested as follows:

4.1.1. Verification of the function of "The System"

As the means of establishing the normal operational levels, verification of the performance of the vehicle system under non-fault conditions shall be conducted against the manufacturer's basic benchmark specification unless this is subject to a specified performance test as part of the approval procedure of this or another Regulation.

4.1.2. Verification of the safety concept of paragraph 3.4.

The reaction of "The System" shall, at the discretion of the type approval authority, be checked under the influence of a failure in any individual unit by applying corresponding output signals to electrical units or mechanical elements in order to simulate the effects of internal faults within the unit.

4.1.2.1. The verification results shall correspond with the documented summary of the failure analysis, to a level of overall effect such that the safety concept and execution are confirmed as being adequate."
