



**Economic and Social  
Council**

Distr.

GENERAL

TRANS/WP.29/708

9 May 2000

ENGLISH

Original: ENGLISH  
and FRENCH

---

**ECONOMIC COMMISSION FOR EUROPE**

INLAND TRANSPORT COMMITTEE

World Forum for Harmonization of Vehicle Regulations (WP.29)

DRAFT SUPPLEMENT 5 TO THE 09 SERIES OF AMENDMENTS  
TO REGULATION No. 13

(Braking)

Note: The text reproduced below was adopted by the Administrative Committee (AC.1) of the amended 1958 Agreement at its fourteenth session, following the recommendation by WP.29 at its one-hundred-and-twentieth session. It is based on documents TRANS/WP.29/1999/23 and TRANS/WP.29/2000/31, as amended (TRANS/WP.29/703, para. 156).

Throughout the Regulation and its annexes, replace the reference to "ISO/DIS 7638:1996" by the reference to "ISO 7638:1997".

Throughout the Regulation and its annexes, replace the reference to "ISO/DIS 11992-1:[1996]" by the reference to "ISO 11992-1:1998"

Throughout the Regulation and its annexes, replace the reference to "ISO/DIS 11992-2:[1996]" by the reference to "ISO 11992-2:1998"

Throughout the Regulation and its annexes, replace the reference to "ISO/DIS 11992-3:[1996]" by the reference to "ISO 11992-3:1998"

Text of the Regulation,

Paragraph 5.1.3.4., amend to read:

"5.1.3.4. In the case of a power-driven vehicle equipped with two control lines as defined in paragraph 5.1.3.1.2., when electrically connected to a trailer which is also equipped with two control lines, the following provisions shall be fulfilled:

5.1.3.4.1. both signals shall be present at the coupling head and the trailer shall use the electric control signal unless this signal is deemed to have failed. In this case the trailer shall automatically switch to the pneumatic control line;.

5.1.3.4.2. each vehicle shall conform to the relevant provisions of annex 10 to this Regulation for both electric and pneumatic control lines; and

5.1.3.4.3. when the electric control signal has exceeded the equivalent of 1 bar for more than 1 second, the trailer shall verify that a pneumatic signal is present; should no pneumatic signal be present, the driver shall be warned from the trailer by the separate yellow warning signal specified in paragraph 5.2.1.29.2. below."

Paragraph 5.1.3.6., amend to read:

"5.1.3.6. The electric control line shall conform to ISO 11992-1 and 11992-2:1998 and be a point-to-point type using the seven pin connector according to ISO 7638-1 or 7638-2:1997. The data contacts of the ISO 7368 connector shall be used to transfer information exclusively for braking (including ABS) and running gear (steering, tyres and suspension) functions as specified in ISO 11992-2 and 11992-3:1998 (those parameters that are permitted and those that are not permitted, to be transferred by the electric control line, are listed in annex 16 to this Regulation). The braking functions have priority and shall be maintained in the normal and failed modes. The transmission of running gear information shall not delay braking functions. The power supply for braking and running gear functions shall be exclusively provided by the ISO 7638 connector. The power supply for all other functions shall use other measures."

Insert a new paragraph 5.1.3.6.1., to read:

"5.1.3.6.1. The functional compatibility of towing and towed vehicles equipped with electric control lines as defined above shall be assessed at the time of type approval by checking that the relevant provisions of ISO 11992:1998 parts 1, 2 and 3 are fulfilled. Annex 17 of this Regulation provides an example of tests that may be used to perform this assessment."

Paragraph 5.1.3.6.1. (former), renumber as paragraph 5.1.3.6.2.

Paragraph 5.1.4.5.2., the table, third row, amend to read (including the addition of the new footnote (4)):

"....."

Trailer control valve or relay (4) emergency valve, as appropriate	Corresponding delivery pressure for a control pressure of 1.5 bar = ..... bar
--	---

Notes: .....

(4) Not applicable for vehicles with electronic control of braking systems."

Insert a new paragraph 5.2.1.2.7.3., to read:

"5.2.1.2.7.3. If the service braking force and transmission depend exclusively on the use of an energy reserve, one energy reserve for the transmission is deemed to be sufficient, provided that the prescribed secondary braking is ensured by the action of the driver's muscular energy acting on the service brake control and the requirements of paragraph 5.2.1.6. are met."

Paragraph 5.2.1.11.1., amend to read:

"5.2.1.11.1. Wear adjustment shall be automatic for the service brakes. However, the fitting of automatic brake adjustment devices is optional for off road vehicles of categories N<sub>2</sub> and N<sub>3</sub> and for the rear brakes of vehicles of categories M<sub>1</sub> and N<sub>1</sub>. Brakes equipped with automatic brake adjustment devices shall, after heating followed by cooling, be capable of free running as defined in paragraph 1.5.4. of annex 4 following the Type-I test also defined in that annex."

Paragraph 5.2.1.21., amend to read:

"... of the towing vehicle. However, automatic application of the trailer brakes alone is permitted for the purpose of vehicle stabilisation. Systems incorporating such a function shall be subject to the provisions of paragraph 5.2.2.5. of this Regulation and its associated footnote."

Paragraph 5.2.1.26.2., amend to read:

"5.2.1.26.2. In the case of a break in the wiring within the electric control transmission external to the electronic control unit(s) and excluding the energy supply, or a failure in the control, it shall remain possible to apply the parking braking system from the driver's seat and thereby be capable of holding the laden vehicle stationary on an 8 per cent up or down gradient. Alternatively, in this case, an automatic actuation of the parking brake is allowed when the vehicle is stationary, provided that the above performance is achieved and, once applied, the parking brake remains engaged independently of the status of the ignition (start) switch. In this alternative, the parking brake shall be automatically released as soon as the driver starts to set the vehicle in motion again. In the case of vehicles of categories  $M_1$  and  $N_1$ , the engine/manual transmission or the automatic transmission (park position) may be used to achieve or assist in achieving the above performance. It shall also be possible to release the parking braking system, if necessary by the use of tools and/or an auxiliary device carried/fitted on the vehicle."

Paragraph 5.2.1.26.2.1., amend to read:

"5.2.1.26.2.1. A break in the wiring within the electric transmission, or a failure in the control of the parking braking system shall be signalled to the driver by the yellow warning signal specified in paragraph 5.2.1.29.1.2. When caused by a break in the wiring within the electric control transmission of the parking braking system, this yellow warning signal shall be signalled as soon as the break occurs. In addition, such a failure in the control or break in the wiring external to the electronic control unit(s) and excluding the energy supply shall be signalled to the driver by flashing the red warning signal specified in paragraph 5.2.1.29.1.1. as long as the ignition (start) switch is in the "on" (run) position including a period of not less than 10 seconds thereafter and the control is in the "on" (activated) position. Where actuation of the parking brake is normally indicated by a separate red warning signal, satisfying all the requirements of 5.2.1.29.3., this signal shall be used to satisfy the above requirement for a red signal."

Paragraph 5.2.1.26.3., amend to read:

"5.2.1.26.3. Auxiliary equipment may be supplied with energy from the electric transmission of the parking braking system provided that the supply of energy is sufficient to allow the actuation of the parking braking system in addition to the vehicle electrical load under non-fault conditions. In addition, where the energy reserve is also used by the service braking system, the requirements of paragraph 5.2.1.27.7. shall apply."

Paragraph 5.2.1.27.1., amend to read:

"5.2.1.27.1. With the parking brake released, the service braking system shall be able to generate a static total braking force at least equivalent to that required by the prescribed Type-0 test, even when the ignition/start switch has been switched off and/or the key has been removed. In the case of ..... "

Paragraph 5.2.1.27.2., amend to read:

"5.2.1.27.2. In the case of a single temporary failure (< 40 ms) within the electric control transmission, excluding its energy supply, (e.g. non-transmitted signal or data error) there shall be no distinguishable effect on the service braking performance."

Paragraph 5.2.1.27.3., amend to read (the footnote does not change):

"5.2.1.27.3. A failure within the electric control transmission 6/, not including its energy reserve, that affects the function and performance of systems addressed in this Regulation shall be indicated to the driver by the red or yellow warning signal specified in paragraphs 5.2.1.29.1.1. and 5.2.1.29.1.2., respectively, as appropriate. .... "

Paragraph 5.2.1.27.7., amend to read:

"5.2.1.27.7. If auxiliary equipment is supplied with energy from the same reserve as the electric control transmission, it shall be ensured that, with the engine running at a speed not greater than 80 per cent of the maximum power speed, the supply of energy is sufficient to fulfil the prescribed deceleration values by either provision of an energy supply which is able to prevent discharge of this reserve when all auxiliary equipment is functioning or by automatically switching off pre-selected parts of the auxiliary equipment at a voltage above the critical level referred to in paragraph 5.2.1.27.6. of this Regulation such that further discharge of this reserve is prevented. Compliance may be demonstrated by calculation or by a practical test. For vehicles authorized to tow a trailer of category O<sub>3</sub> or O<sub>4</sub> the energy consumption of the trailer shall be taken into account by a load of 400 W. This paragraph does not apply to vehicles where the prescribed deceleration values can be reached without the use of electrical energy."

Paragraph 5.2.1.27.10., amend to read:

"5.2.1.27.10. In the case of a failure in the electric control transmission of a trailer, electrically connected via an electric control line only, according to paragraph 5.1.3.1.3., braking of the trailer shall be ensured according to paragraph 5.2.1.18.4.1. This shall be the case whenever the trailer provides the "supply line braking request" signal via the data communication part of the electric control line or in the event of the continuous absence of this data communication. This paragraph shall not apply to

power-driven vehicles which cannot be operated with trailers connected via an electric control line only, as described in paragraph 5.1.3.5."

Paragraph 5.2.1.28.2.1., amend to read:

"5.2.1.28.2.1. The coupling force control may control the braking rate  $T_M/P_M$  and/or the brake demand value(s) for the trailer. In the case of a towing vehicle equipped with two control lines according to paragraph 5.1.3.1.2. above, both signals shall be subject to similar control adjustments."

Paragraph 5.2.1.29., amend to read:

"5.2.1.29. The general requirements for optical warning signals whose function is to indicate to the driver certain specified failures (or defects) within the braking equipment of the power-driven vehicle or, where appropriate, its trailer, are set out in the following sub-paragraphs. Other than as described in paragraph 5.2.1.29.6. below, these signals shall be used exclusively for the purposes prescribed by this Regulation."

Paragraph 5.2.1.29.1.1., amend to read:

"5.2.1.29.1.1. a red warning signal, indicating failures defined elsewhere in this Regulation within the vehicle braking equipment which preclude achievement of the prescribed service braking performance and/or which preclude the functioning of at least one of two independent service braking circuits;"

Paragraph 5.2.1.29.2., including its footnote, amend to read:

"5.2.1.29.2. With the exception of vehicles of categories  $M_1$  and  $N_1$ , power-driven vehicles equipped with an electric control line and/or authorised to tow a trailer equipped with an electric control transmission and/or anti-lock braking system, shall be capable of providing a separate yellow warning signal to indicate a defect within the anti-lock braking system and/or electric control transmission of the braking equipment of the trailer. The signal shall be activated from the trailer via pin 5 of the electric connector conforming to ISO 7638:1997 <sup>\*</sup>/ and in all cases the signal transmitted by the trailer shall be displayed without significant delay or modification by the towing vehicle. This warning signal shall not light up when coupled to a trailer without an electric control line and/or electric control transmission and/or anti-lock braking system or when no trailer is coupled. This function shall be automatic.

---

<sup>\*</sup>/ The ISO 7638:1997 connector may be used for 5 pin or 7 pin applications, as appropriate."

Paragraph 5.2.1.29.4., amend to read:

- "5.2.1.29.4. Except where stated otherwise:
- 5.2.1.29.4.1. a specified failure or defect shall be signalled to the driver by the above-mentioned warning signal(s) not later than on actuation of the relevant braking control;
- 5.2.1.29.4.2. the warning signal(s) shall remain displayed as long as the failure/defect persists and the ignition (start) switch is in the "on" (run) position; and
- 5.2.1.29.4.3. the warning signal shall be constant (not flashing)."

Insert new paragraphs 5.2.1.29.6. to 5.2.1.29.6.3., to read:

- "5.2.1.29.6. Non-specified failures (or defects), or other information concerning the brakes and/or running gear of the power-driven vehicle, may be indicated by the yellow signal specified in paragraph 5.2.1.29.1.2. above, provided that all the following conditions are fulfilled:
- 5.2.1.29.6.1. the vehicle is stationary;
- 5.2.1.29.6.2. after the braking equipment is first energised and the signal has indicated that, following the procedures detailed in paragraph 5.2.1.29.5. above, no specified failures (or defects) have been identified; and
- 5.2.1.29.6.3. non-specified faults or other information shall be indicated only by the flashing of the warning signal. However, the warning signal shall be extinguished by the time when the vehicle first exceeds 10 km/h."

Paragraph 5.2.2.8.1., amend to read:

- "5.2.2.8.1. Wear adjustment shall be automatic for the service brakes. However, the fitting of automatic adjustment devices is optional for vehicles of categories O<sub>1</sub> and O<sub>2</sub>. Brakes equipped with automatic brake adjustment devices shall, after heating followed by cooling, be capable of free running as defined in paragraph 1.7.3. of annex 4 following the Type-I or Type-III test also defined in that annex as appropriate."

Insert new paragraphs 5.2.2.8.1.1. and 5.2.2.8.1.2., to read:

- "5.2.2.8.1.1. In the case of trailers of category O<sub>4</sub> the performance requirements of paragraph 5.2.2.8.1. above shall be deemed to be satisfied by fulfilling the requirements of paragraph 1.7.3. of annex 4.
- 5.2.2.8.1.2. In the case of trailers of categories O<sub>2</sub> and O<sub>3</sub> the performance requirements of paragraph 5.2.2.8.1. above shall

be deemed to be satisfied by fulfilling the requirements of paragraph 1.7.3. 8/ of annex 4."

Note 8/ (pertinent to paragraph 5.2.2.8.2.), amend to read:

"8/ Until uniform technical provisions have been agreed that correctly assess the function of the automatic brake adjustment device, the free running requirement shall be deemed to be fulfilled when free running is observed during all brake tests prescribed for the relevant trailer."

Paragraph 5.2.2.15.1., amend to read:

"5.2.2.15.1. In the case of a single temporary failure (< 40 ms) within the electric control transmission, excluding its energy supply, (e.g. non-transmitted signal or data error) there shall be no distinguishable effect on the service braking performance."

Paragraph 5.2.2.15.2., amend to read:

"5.2.2.15.2. In the case of a failure within the electric control transmission (e.g. breakage, disconnection), a braking performance of at least 30 per cent of the prescribed performance for the service braking system of the relevant trailer shall be maintained. For trailers, electrically connected via an electric control line only, according to paragraph 5.1.3.1.3., and fulfilling 5.2.1.18.4.2. with the performance prescribed in paragraph 3.3. of annex 4 to this Regulation, it is sufficient that the provisions of paragraph 5.2.1.27.10. are invoked, when a braking performance of at least 30 per cent of the prescribed performance for the service braking system of the trailer can no longer be ensured, by either providing the "supply line braking request" signal via the data communication part of the electric control line or by the continuous absence of this data communication."

Paragraph 5.2.2.15.2.1. and its corresponding footnote \*/, amend to read:

"5.2.2.15.2.1. A failure within the electric control transmission of the trailer, not including its energy reserve, that affects the function and performance of systems addressed in this Regulation, shall be indicated to the driver by the separate warning signal specified in paragraph 5.2.1.29.2. via pin 5 of the electrical connector conforming to ISO 7638:1997. \*/. In addition, ... "

---

\*/ Until uniform test procedures have been agreed, the manufacturer shall provide the Technical Service with an analysis of potential failures within the control transmission, and their effects. This information shall be subject to discussion and agreement between the Technical Service and the vehicle manufacturer. The ISO 7638:1997 connector may be used for 5 pin or 7 pin applications, as appropriate."



Paragraph 5.2.2.17., amend to read:

" ... shall be activated via the above connector. The requirement to be applied to trailers with respect to the transmission of failure warning signals shall be those, as appropriate, which are prescribed for motor vehicles in paragraphs 5.2.1.29.4., 5.2.1.29.5. and 5.2.1.29.6."

Paragraph 5.2.2.18., delete the reference to footnote \*/.

Annex 2,

Item 14.3. (first column of the table), amend to read (extension from 2 to 3 test result lines and inclusion of new footnotes 4/ and 5/):

"14.3. Type-I tests:

with repeated braking 5/

with continuous braking 4/"

Free running, in accordance with annex 4, paragraph 1.5.4. 5/ and annex 4, paragraph 1.7.3. 4/ respectively"

Item 14.5. (first column of the table), amend to read (extension from 1 to 3 test result lines and inclusion of a new footnote 6/):

"14.5. Type-III tests 6/:

Free running, in accordance with annex 4, paragraph 1.7.3."

Annex 4,

Add a new paragraph 1.5.1.7., to read:

"1.5.1.7. In the case of vehicles equipped with automatic brake adjustment devices the adjustment of the brakes shall, prior to the Type-I test above, be set according to the following procedures as appropriate:

1.5.1.7.1. In the case of vehicles equipped with air operated brakes the adjustment of the brakes shall be such as to enable the automatic brake adjustment device to function. For this purpose the actuator stroke shall be adjusted to

---

5/ Applies only to power-driven vehicles.

4/ Applies only to vehicles of categories 0<sub>2</sub> and 0<sub>3</sub>.

6/ Applies only to vehicles of category 0<sub>4</sub>.

$s_o$  § 1.1 "  $s_{re-adjust}$  (the upper limit shall not exceed a value recommended by the manufacturer)  
where:

$s_{re-adjust}$  is the re-adjustment stroke according to the specification of the manufacturer of the automatic brake adjustment device, i.e. the stroke, where it starts to readjust the running clearance of the brake with an actuator pressure of 15 per cent of the brake system operating pressure but not less than 1.0 bar.

Where, by agreement with the Technical Service, it is impractical to measure the actuator stroke, the initial setting shall be agreed with the Technical Service.

From the above condition the brake shall be operated with an actuator pressure of 30 per cent of the brake system operating pressure but not less than 2.0 bar, 50 times in succession. This shall be followed by a single brake application with an actuator pressure of § 6.5 bar.

1.5.1.7.2. In the case of vehicles equipped with hydraulically operated disc brakes no setting requirements are deemed necessary.

1.5.1.7.3. In the case of vehicles equipped with hydraulically operated drum brakes the adjustment of the brakes shall be as specified by the manufacturer."

Add a new paragraph 1.5.2.3., to read:

"1.5.2.3. In the case of trailers equipped with automatic brake adjustment devices the adjustment of the brakes shall, prior to the Type-I test prescribed above, be set according to the procedure as laid down in paragraph 1.7.1.1. of this annex."

Add a new paragraph 1.5.4., to read:

"1.5.4. Free running test

In the case of motor vehicles equipped with automatic brake adjustment devices, the brakes after completing the tests defined in paragraph 1.5.3 above will be allowed to cool to a temperature representative of a cold brake (i.e. # 100 EC) and it shall be verified that the vehicle is capable of free running by fulfilling one of the following conditions:

- a) Wheels are running freely (i.e. may be rotated by hand)
- b) It is ascertained that when the vehicle is driven at a constant speed of  $v = 60$  km/h with the brakes released the asymptotic temperatures shall not exceed a drum/disc temperature increase of 80 EC, then the residual brake

moments are regarded as acceptable."

Paragraph 1.7.1., amend to read:

"1.7.1. Track test

1.7.1.1. The adjustment of the brakes shall, prior to the Type-III test below, be set according to the following procedures as appropriate:

1.7.1.1.1. In the case of trailers equipped with air operated brakes the adjustment of the brakes shall be such as to enable the automatic brake adjustment device to function. For this purpose the actuator stroke shall be adjusted to

$s_0 \leq 1.1 \cdot s_{re-adjust}$  (the upper limit shall not exceed a value recommended by the manufacturer)

where:

$s_{re-adjust}$  is the re-adjustment stroke according to the specification of the manufacturer of the automatic brake adjustment device, i.e. the stroke, where it starts to re-adjust the running clearance of the brake with an actuator pressure of 1.0 bar.

Where, by agreement with the Technical Service, it is impractical to measure the actuator stroke, the initial setting shall be agreed with the Technical Service.

From the above condition the brake shall be operated with an actuator pressure of 2.0 bar, 50 times in succession. This shall be followed by a single brake application with an actuator pressure of  $\leq 6.5$  bar.

1.7.1.1.2. In the case of trailers equipped with hydraulically operated disc brakes no setting requirements are deemed necessary.

1.7.1.1.3. In the case of trailers equipped with hydraulically operated drum brakes the adjustment of the brakes shall be as specified by the manufacturer.

1.7.1.2. For the road test the conditions shall be as follows:  
number of brake application: 20.  
(etc. .... remaining old text of paragraph 1.7.1. unchanged)"

Add a new paragraph 1.7.3., to read:

"1.7.3. Free running test

After completing the tests defined in paragraph 1.7.2, above, the brakes will be allowed to cool to a temperature representative of a cold brake (i.e.  $\leq 100$  EC) and it shall be verified that the trailer is capable of free running by

fulfilling one of the following conditions:

- a) Wheels are running freely (i.e. may be rotated by hand)
- b) It is ascertained that when the trailer is driven at a constant speed of  $v = 60$  km/h with the brakes released the asymptotic temperatures shall not exceed a drum/disc temperature increase of 80 EC, then the residual brake moments are regarded as acceptable."

Annex 6, paragraphs 3.4. and 3.5. (including the footnote of paragraph 3.5.), amend to read:

- "3.4. The simulator for checking the response to signals transmitted via the electric control line shall have the following characteristics:
  - 3.4.1. The simulator shall produce a digital demand signal in the electric control line according to ISO 11992:1998 and shall provide the appropriate information to the trailer via pins 6 and 7 of the ISO 7638:1997 connector. For the purpose of response time measurement the simulator may at the manufacturer's request transmit to the trailer information that no pneumatic control line is present and that the electric control line demand signal is generated from two independent circuits (see paragraph 5.4.2.25 and 5.4.2.26 of ISO 11992-2:1998).
  - 3.4.2. The braking system control must be so designed that its performance in use is not affected by the tester.
  - 3.4.3. For the purpose of response time measurement the signal produced by the electric simulator shall be equivalent to a linear pneumatic pressure increase from 0.0 to 6.5 bar in  $0.2 \pm 0.01$  seconds.
  - 3.4.4. The diagrams in the appendix to this annex give an example of the correct configuration of the simulator for setting and use.
- 3.5. Performance requirements
  - 3.5.1. For trailers with a pneumatic control line the time elapsing between the moment when the pressure produced in the control line by the simulator reaches 0.65 bar and the moment when the pressure in the brake actuator of the trailer reaches 75 per cent of its asymptotic value must not exceed 0.4 seconds.
    - 3.5.1.1. Trailers equipped with a pneumatic control line and having electric control transmission shall be checked with the electrical power supplied to the trailer via the ISO 7638:1997 connector (5 or 7 pin).
  - 3.5.2. For trailers with an electric control line the time elapsing

between the moment when the signal produced by the simulator exceeds the equivalent of 0.65 bar and the moment when the pressure in the brake actuator of the trailer reaches 75 per cent of its asymptotic value must not exceed 0.4 seconds.

3.5.3. In the case of trailers equipped with a pneumatic and an electric control line, the response time measurement for each control line shall be determined independently according to the relevant procedure defined above."

Annex 6, appendix, insert a new figure 3., to read:

"3. Example of a simulator for electric control lines

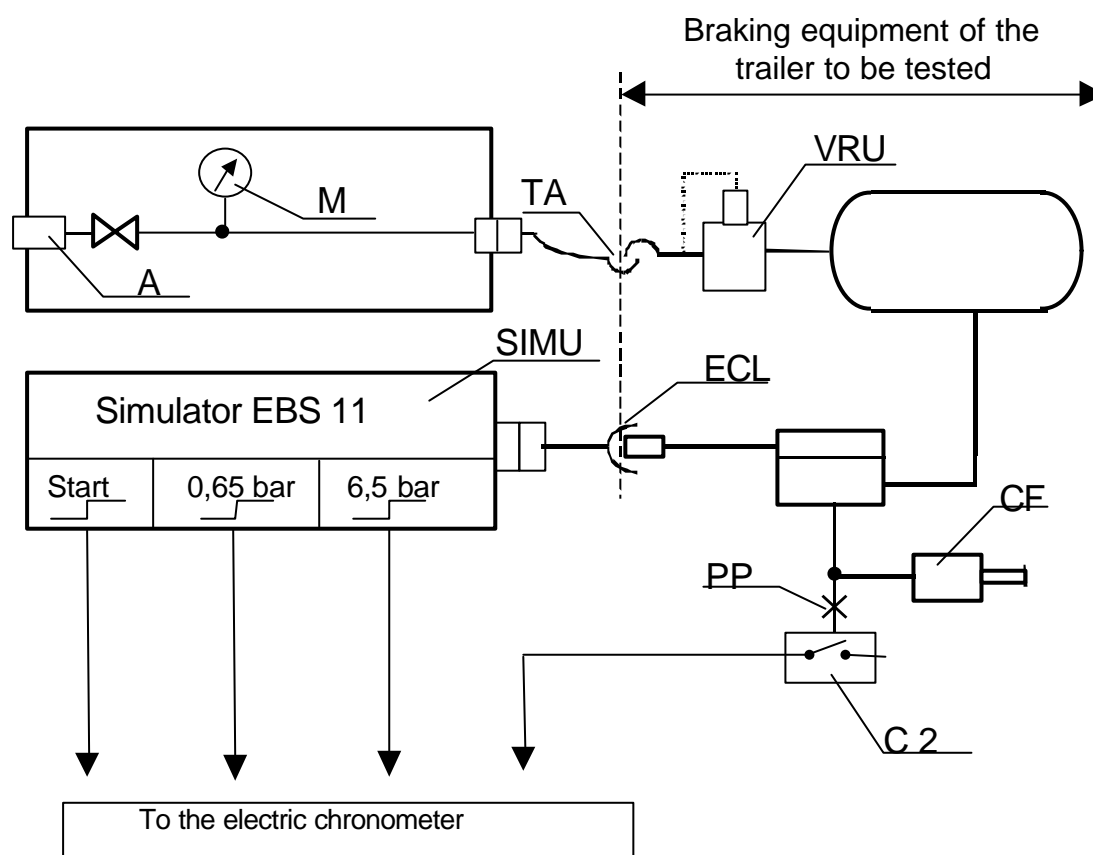

ECL = electric control line corresponding to ISO 7638

SIMU = simulator of Byte 3,4 of EBS 11 according to ISO 11992 with output signals at start, 0.65 bar and 6.5 bar."

Annex 11 - Appendix 2,

Insert new paragraphs 1.3. to 1.5., to read:

- "1.3. Tests carried out in accordance with paragraph 3.6. of this appendix and the results reported in section 2 of Appendix 3 or Appendix 4 shall be acceptable as a means of proving compliance with the requirements of paragraph 5.2.2.8.1. of this Regulation."
- 1.4. The adjustment of the brake(s) shall, prior to the Type-III test below, be set according to the following procedures as appropriate:
- 1.4.1. In the case of air operated trailer brake(s), the adjustment of the brakes shall be such as to enable the automatic brake adjustment device to function. For this purpose the actuator stroke shall be adjusted to
- $s_0 \leq 1.1 \cdot s_{re-adjust}$  (the upper limit shall not exceed a value recommended by the manufacturer),
- where:
- $s_{re-adjust}$  is the re-adjustment stroke according to the specification of the manufacturer of the automatic brake adjustment device, i.e. the stroke, where it starts to re-adjust the running clearance of the brake with an actuator pressure of 1.0 bar.
- Where, by agreement with the Technical Service, it is impractical to measure the actuator stroke, the initial setting shall be agreed with the Technical Service.
- From the above condition the brake shall be operated with an actuator pressure of 2.0 bar, 50 times in succession. This shall be followed by a single brake application with an actuator pressure of  $\leq 6.5$  bar.
- 1.4.2. In the case of hydraulically operated trailer disc brakes no setting requirements are deemed necessary.
- 1.4.3. In the case of hydraulically operated trailer drum brakes the adjustment of the brakes shall be as specified by the manufacturer.
- 1.5. In the case of trailers equipped with automatic brake adjustment devices the adjustment of the brakes shall, prior to the Type-I test below, be set according to the procedure as laid down in paragraph 1.4. above."

Paragraph 2, after " $s_p$ ", insert a new symbol and definition for " $s_A$ " to read:

" $s_A$  = actuator stroke of the brake equipped with an automatic brake adjustment device"

Paragraphs 3.2.3. and 3.3.2., amend to read:

"... the speed of the airflow being

$$v_{\text{air}} = 0.33 v$$

where:

v = vehicle test speed at initiation of braking."

Insert new paragraphs 3.6. to 3.6.3., to read:

"3.6. Performance requirements for automatic brake adjustment devices

3.6.1. The following requirements shall apply to an automatic brake adjustment device which is installed on a brake, the performance of which is being verified according to the provisions of this appendix.

On completion of the tests defined in paragraphs 3.5.2.4. (Type-I test) or 3.5.3.2 (Type-III test) above, the requirements of paragraph 3.6.3. below shall be verified.

3.6.2. The following requirements shall apply to an alternative automatic brake adjustment device installed on a brake for which an appendix 3 test report already exists.

3.6.2.1. Brake performance

Following heating of the brake(s) carried out in accordance with the procedures defined in paragraphs 3.5.2. (Type-I test) or 3.5.3 (Type-III test), as appropriate, one of the following provisions shall apply:

a) The hot performance of the service braking system shall be  $\geq 80$  per cent of the prescribed Type-0 performance; or

b) The brake shall be applied with a brake actuator pressure as used during the Type-0 test; at this pressure the total actuator stroke ( $s_A$ ) shall be measured and shall be  $\geq 0.9 s_p$  value of the brake chamber.

$s_p$  = The effective stroke means the stroke at which the output thrust is 90 per cent of the average thrust ( $Th_A$ ) - see paragraph 2. of annex 11 - appendix 2 to this Regulation.

3.6.2.2. On completion of the tests defined in paragraph 3.6.2.1. above the requirements of paragraph 3.6.3. below shall be verified.

3.6.3. Free running test

After completing the tests defined in paragraphs 3.6.1. or

3.6.2. above, as applicable, the brake(s) shall be allowed to cool to a temperature representative of a cold brake (i.e. # 100E C) and it should be verified that the trailer/wheel(s) is capable of free running by fulfilling one of the following conditions:

- a) Wheels are running freely (i.e. wheels can be rotated by hand)
- b) It is ascertained that at a constant speed equivalent to  $v = 60$  km/h with the brake(s) released the asymptotic temperature shall not exceed a drum/disc temperature increase of 80E C, then this residual brake moment is regarded as acceptable."

Paragraphs 3.6. to 3.6.2.(former), renumber as paragraphs 3.7. to 3.7.2., and amend to read:

"3.7. Test report

3.7.1. The result of tests carried out in accordance with paragraphs 3.5. and 3.6.1. of this appendix shall be reported on a form, a model of which is shown in appendix 3 to this annex.

3.7.2. The brake and the axle shall be identified. Particulars of the brakes, the axle, the technically permissible mass and the number of the corresponding appendix 3 test report shall be marked on the axle."

Insert a new paragraph 3.7.3., to read:

"3.7.3. In the case of a brake installed with an alternative brake adjustment device the results of tests carried out in accordance with paragraph 3.6.2. of this appendix shall be reported on a form a model of which is shown in appendix 4 to this annex."

Annex 11 - Appendix 3,

The title, amend to read:

"Annex 11 - Appendix 3

MODEL TEST REPORT FORM AS PRESCRIBED IN PARAGRAPHS 3.7.1. AND 3.7.2. OF APPENDIX 2 TO THIS ANNEX"

Item 1.2. after "Technically permissible camshaft input torque  $C_{max}$ ", insert the following text:

"Automatic brake adjustment device: integrated/  
non-integrated 1/"

Add a new item 1.6., to read:



"1.6. 4/ Automatic brake adjustment device (not applicable in the case of integrated automatic brake adjustment device)  
  
Manufacturer (name and address): .....  
Make: .....  
Type: .....  
Version: ....."

Add new items 2.3. to 6., to read:

"2.3. Performance of the automatic brake adjustment device  
(if applicable)  
  
2.3.1. Free running according to paragraphs 3.6.1. and 3.6.3. of  
Annex 11, Appendix 2: yes / no 1/  
  
3. Name of Technical Service/Type Approval Authority 1/ conducting  
the test: .....  
  
4. Date of test: .....  
  
5. This test has been carried out and the results reported in  
accordance with Regulation No. 13, paragraph 4. and annex 11,  
Appendix 2.  
  
6. 4/ At the end of test defined in paragraph 3.6. of annex 11,  
Appendix 2 the requirements of paragraph 5.2.2.8.1. of  
Regulation No. 13 were deemed to be fulfilled / not fulfilled 1/  
  
SIGNED . . . . .  
  
DATE . . . . . "

---

4/ Only to be completed when an automatic brake wear adjustment device is installed.

Add a new Annex 11, Appendix 4, to read:

"Annex 11 - Appendix 4

MODEL TEST FOR AN ALTERNATIVE AUTOMATIC BRAKE ADJUSTMENT DEVICE FORM AS  
PRESCRIBED IN PARAGRAPH 3.7.3. OF APPENDIX 2 TO THIS ANNEX

TEST REPORT No. ....

1. IDENTIFICATION

1.1. Axle:

Make: .....  
Type: .....  
Model: .....  
Technically permissible axle load ( $P_e$ ) .....daN  
Annex 11 Appendix 3 Test Report No. ....

1.2. Brake:

Make: .....  
Type: .....  
Model: .....  
Brake lining: .....  
Make/Type: .....

1.3. Actuation:

Manufacturer: .....  
Type (cylinder/diaphragm) 1/: .....  
Model: .....  
Lever length (l): .....mm

1.4. Automatic brake adjustment device:

Manufacturer (name and address): .....  
Make: .....  
Type: .....  
Version: .....

2. RECORD OF TEST RESULTS

2.1. Performance of the automatic brake adjustment device

- 2.1.1.1. Hot performance of service braking systems determined according to the test defined in paragraph 3.6.2.1. (a) of annex 11, Appendix 2: ...%  
or  
Actuator stroke  $s_A$  determined according to the test defined in paragraph 3.6.2.1. (b) of annex 11, Appendix 2: . . . . . mm
- 2.1.1.2. Free running according to paragraphs 3.6.2.2. and 3.6.3. of annex 11, Appendix 2:       yes / no 1/
- 3.     Name of Technical Service/Type Approval Authority 1/ conducting the test: . . . . .
- 4.     Date of test: . . . . .
- 5.     This test has been carried out and the results reported in accordance with Regulation No. 13, annex 11, Appendix 2, paragraph 3.6.2.
- 6.     At the end of test defined in item 5 above the requirements of paragraph 5.2.2.8.1. of Regulation No. 13 were deemed to be fulfilled / not fulfilled 1/

SIGNED . . . . .  
DATE . . . . .

\_\_\_\_\_

\_\_\_\_\_

1/     Strike out what does not apply"

Annex 13, paragraph 4.5.2., amend to read:

" .... for this purpose. The warning signal may be constant or flashing;"

Annex 15, paragraph 3.4., amend to read:

".... The velocity of the cooling air over the brake shall be  
 $v_{air} = 0.33 v$   
where:  
 $v$  = vehicle test speed at initiation of braking."

Insert new annexes 16 and 17. to read:

"Annex 16

INTERPRETATION OF ISO 11992-2 AND 11992-3:1998 FOR THE PURPOSES OF  
PARAGRAPH 5.1.3.6. OF THIS REGULATION

1. The following parameters of ISO 11992-3:1998 shall not be transferred by the electric control line defined in paragraph 5.1.3.6. of this Regulation.

Parameter	Paragraph of ISO 11992-3:1998
Obstacle detection device (ODD)	5.4.2.2.
Thermal body temperature	5.4.2.3.
Obstacle detection device (ODD) request	5.4.2.12.
Anti-theft device request	5.4.2.13.
Obstacle detection device (ODD) status	5.4.2.20.
Anti-theft device	5.4.2.21.

2. The following parameters of ISO 11992-3:1998 shall be transferred, if applicable, by the electric control line defined in paragraph 5.1.3.6. of this Regulation.

Parameter	Paragraph of ISO 11992-3:1998
Driven axle load (commercial vehicle)	5.4.2.8.
Nominal vehicle body level	5.4.2.9.
Lift axle position request	5.4.2.10.
Steering axle locking request	5.4.2.11.
Traction help (load transfer) request	5.4.2.14.
Ride height request	5.4.2.15.
Level change request	5.4.2.16.
Ramp level request	5.4.2.17.
Lift axle position	5.4.2.18.
Steering axle locking	5.4.2.19.
Traction help (load transfer)	5.4.2.26.
Levelling control system, right height level	5.4.2.27.
Level control	5.4.2.28.
Ramp level position	5.4.2.29.

3. The following parameters of ISO 11992-3:1998 are identical copies of parameters defined in ISO 11992-2:1998. These parameters shall only be transmitted, if applicable, via the electric control line defined in paragraph 5.1.3.6. of this Regulation.

Parameter	Paragraph of ISO 11992-3:1998
Tyre identification	5.4.2.4.
Tyre pressure	5.4.2.5.
Brake lining	5.4.2.6.
Brake temperature	5.4.2.7.
Vehicle pneumatic supply sufficient/insufficient	5.4.2.22.
Tyre pressure sufficient/insufficient	5.4.2.23.
Brake lining sufficient/insufficient	5.4.2.24.
Brake temperature status	5.4.2.25.

4. The following parameter of ISO 11992-3:1998 is a copy of a parameter defined in ISO 11992-2:1998. It is a general parameter that is not designated to a specific function. This parameter may be transmitted by other means in addition to the electric control line defined in paragraph 5.1.3.6. of this Regulation.

Parameter	Paragraph of ISO 11992-3:1998
Trailer type (vehicle type)	5.4.2.30.

5. These arrangements lead to the following consequences on message level:

Message	Paragraph of ISO 11992-3:1998	Consequence
GFM 11	5.5.2.1.	Not to be transmitted via the electric control line.
GFM 12	5.5.2.2.	To be transmitted via the electric control line.
GFM 21	5.5.3.1.	Not to be transmitted via the electric control line.
GFM 22	5.5.3.2.	To be transmitted via the electric control line.
GFM 23	5.5.3.3.	To be deleted.
GFM 24	5.5.3.4.	Not to be transmitted via the electric control line.

Therefore, the parameters "driven axle load", "obstacle detection device (ODD) status" and "anti-theft device" of ISO 11992-3:1998 cannot be transmitted because of their inadequate assignment to messages.

---

Annex 17

TEST PROCEDURE TO ASSESS THE FUNCTIONAL COMPATIBILITY OF VEHICLES EQUIPPED WITH ELECTRIC CONTROL LINES

1. GENERAL
- 1.1. This annex defines a procedure that may be used to check towing and towed vehicles equipped with an electric control line against the functional and performance requirements referred to in paragraph 5.1.3.6.1. of this Regulation. Alternative procedures may be used at the discretion of the Technical Service if an equivalent level of checking integrity can be established.

- 1.2. The references to ISO 7638 within this annex apply to ISO 7638-1:1997 for 24V applications and ISO 7638-2:1997 for 12V applications.
2. INFORMATION DOCUMENT
  - 2.1. The vehicle manufacturer/system supplier shall supply to the Technical Service an Information Document that contains at least the following:
    - 2.1.1. a schematic of the vehicle braking system;
    - 2.1.2. evidence that the interface, including the physical layer, data link layer and the application layer and the respective position of supported messages and parameters, complies with ISO 11992;
    - 2.1.3. a list of supported messages and parameters; and
    - 2.1.4. the specification of the motor vehicle with respect to the number of control circuits that signal the pneumatic and/or electric control lines.
3. TOWING VEHICLES
  - 3.1. ISO 11992 Trailer simulator

The simulator shall:

    - 3.1.1. have a connector meeting ISO 7638:1997 (7 pin) to connect to the vehicle under test. Pins 6 and 7 of the connector shall be used to transmit and receive messages complying with ISO 11992;
    - 3.1.2. be capable of receiving all of the messages transmitted by the motor vehicle to be type approved and be capable of transmitting all trailer messages defined within ISO 11992-2:1998 and ISO 11992-3:1998, with the exception of those messages specifically prohibited by this Regulation;
    - 3.1.3. provide a direct or indirect readout of messages, with the parameters in the data field shown in the correct order relative to time; and
    - 3.1.4. include a facility to measure coupling head response time in accordance with paragraph 2.6. of annex 6 to this Regulation.
  - 3.2. Checking procedure
    - 3.2.1. Confirm that the manufacturer's/supplier's information document demonstrates compliance with the provisions of ISO 11992 with respect to the physical layer, data link layer and application layer.

3.2.2. Check the following, with the simulator connected to the motor vehicle via the ISO 7638 interface and whilst all trailer messages relevant to the interface are being transmitted:

3.2.2.1. Control line signalling:

3.2.2.1.1. The parameters defined in EBS 12 byte 3 of ISO 11992-2 shall be checked against the specification of the vehicle as follows:

Control Line Signalling	EBS 12 Byte 3	
	Bits 1 - 2	Bits 5 - 6
Service braking demand generated from one electrical circuit	00b	
Service braking demand generated from two electrical circuits	01b	
Vehicle is not equipped with a pneumatic control line <u>1/</u>		00b
Vehicle is equipped with a pneumatic control line		01b

---

1/ This specification of vehicle is prohibited by footnote 1/ to paragraph 5.1.3.1.3. of this Regulation.

3.2.2.2. Service/Secondary brake demand:

3.2.2.1.1 The parameters defined in EBS 11 of ISO 11992-2 shall be checked as follows:

Test condition	Byte Reference	Signal Status
Service brake pedal and secondary brake control released	3 - 4	0
Service brake pedal fully applied	3 - 4	33280d to 43520d (6.5 to 8.5bar)
Secondary brake fully applied <u>2/</u>	3 - 4	33280d to 43520d (6.5 to 8.5bar)

---

2/ Optional on towing vehicles with electric and pneumatic control lines when the pneumatic control line fulfils the relevant requirements for secondary braking



- 3.2.2.3. Failure warning:
  - 3.2.2.3.1. Simulate a permanent failure in the communication line to pin 6 of the ISO 7638 connector and check that the yellow warning signal specified in paragraph 5.2.1.29.2. of this Regulation is displayed.
  - 3.2.2.3.2. Simulate a permanent failure in the communication line to pin 7 of the ISO 7638 connector and check that the yellow warning signal specified in paragraph 5.2.1.29.2. of this Regulation is displayed.
  - 3.2.2.3.3. Simulate message EBS 22, byte 2 with bits 3 - 4 set to 01b and check that the red warning signal specified in paragraph 5.2.1.29.1.1. of this Regulation is displayed.
- 3.2.2.4. Response time:
  - 3.2.2.4.1. Check that, with no faults present, the control line response requirements defined in item 2.6. of annex 6 to this Regulation are met.
- 3.2.3. Additional checks
  - 3.2.3.1. At the discretion of the Technical Service the checking procedures defined above may be repeated with the non-braking functions relevant to the interface in different states or switched off.
- 4. TRAILERS
  - 4.1. ISO 11992 Towing vehicle simulator

The simulator shall:

    - 4.1.1. have a connector meeting ISO 7638:1997 (7 pin) to connect to the vehicle under test. Pins 6 and 7 of the connector shall be used to transmit and receive messages complying with ISO 11992;
    - 4.1.2. have a failure warning display and an electrical power supply for the trailer;
    - 4.1.3. shall be capable of receiving all of the messages transmitted by the trailer to be type approved and be capable of transmitting all motor vehicle messages defined within ISO 11992-2:1998 and ISO 11992-3:1998, with the exception of those messages specifically prohibited by this Regulation.
    - 4.1.4. provide a direct or indirect readout of messages with the parameters in the data field shown in the correct order relative to time; and
    - 4.1.5. include a facility to measure brake system response time in accordance with paragraph 3.5.2. of annex 6 to this Regulation.

4.2. Checking procedure

4.2.1. Confirm that the manufacturer's/supplier's Information Document demonstrates compliance with the provisions of ISO 11992 with respect to the physical layer, data link layer and application layer.

4.2.2. Check the following, with the simulator connected to the trailer via the ISO 7638 interface and whilst all towing vehicle messages relevant to the interface are being transmitted:

4.2.2.1. Service brake system function:

4.2.2.1.1. The trailer response to the parameters defined in EBS 11 of ISO 11992-2 shall be checked as follows:

The pressure in the supply line at the start of each test shall be  $\geq 7$  bar and the vehicle shall be laden (the loading condition may be simulated for the purpose of this check).

4.2.2.1.1.1. For trailers equipped with pneumatic and electric control lines:

both control lines shall be connected  
 both control lines shall be signalled simultaneously  
 the simulator shall transmit message byte 3, bits 5 - 6 of EBS 12 set to 01b to indicate to the trailer that a pneumatic control line should be connected

Parameters to be checked:

Message Transmitted by the Simulator		Pressure at the Brake Chambers
Byte Reference	Status	
3 - 4	0	0 bar
3 - 4	33280d (6.5 bar)	As defined in the vehicle manufacturer's brake calculation

4.2.2.1.1.2. Trailers equipped with pneumatic and electric control lines or an electric control line only:

Only the electric control line shall be connected  
 The simulator shall transmit the following messages:  
 Byte 3, bits 5 - 6 of EBS 12 set to 00b to indicate to the trailer that a pneumatic control line is not available,  
 and byte 3, bits 1 - 2 of EBS 12 set to 01b to indicate to the trailer that the electric control line signal is generated from two electric circuits.

Parameters to be checked:

Message Transmitted by the Simulator		Pressure at the Brake Chambers
Byte Reference	Status	
3 - 4	0	0 bar
3 - 4	33280d (6.5 bar)	As defined in the vehicle manufacturers brake calculation

4.2.2.1.2. For trailers equipped with only an electric control line, the response to messages defined in EBS 12 of ISO 11992-2 shall be checked as follows:

The pneumatic supply line at the start of each test shall be \$ 7 bar.

The electric control line shall be connected to the simulator.

The simulator shall transmit the following messages:

Byte 3, bits 5 - 6 of EBS 12 set to 01b to indicate to the trailer that a pneumatic control line is available.

Byte 3-4 of EBS 11 shall be set to 0 (no service brake demand)

The response to the following messages shall be checked:

EBS 12, Byte 3, Bit 1-2	Pressure in the brake chambers or reaction of the trailer
01b	0 bar (service brake released)
00b	The trailer is automatically braked to demonstrate that the combination is not compatible. A signal should also be transmitted via Pin 5 of the ISO 7638:1997 connector (yellow warning).

4.2.2.2. Failure warning

4.2.2.2.1. Check that the appropriate warning message or signal is transmitted under the following conditions:

4.2.2.2.1.1. Simulate a permanent failure within the electric control transmission of the trailer braking system which precludes the service braking system performance being met, and check that byte 2, bits 3 - 4 of EBS 22 transmitted by the trailer is set

to 01b. A signal should also be transmitted via pin 5 of the ISO 7638 connector (yellow warning).

- 4.2.2.2.1.2. Reduce the voltage on pins 1 and 2 of the ISO 7638 connector to below a value nominated by the manufacturer which precludes the service braking system performance from being fulfilled and check that byte 2, bits 3 - 4 of EBS 22 transmitted by the trailer are set to 01b. A signal should also be transmitted via pin 5 of the ISO 7638 connector (yellow warning).
- 4.2.2.2.1.3. Check compliance with the provisions of paragraph 5.2.2.16. of this Regulation by isolating the supply line. Reduce the pressure in the trailer pressure storage system to the value nominated by the manufacturer. Check that byte 2, bits 3 - 4 of EBS 22 transmitted by the trailer is set to 01b and that byte 1, bits 7 - 8 of EBS 23 is set to 00. A signal should also be transmitted via pin 5 of the ISO 7638 connector (yellow warning).
- 4.2.2.2.1.4. When the electrical part of the braking equipment is first energised check that byte 2, bits 3 - 4 of EBS 22 transmitted by the trailer is set to 01b. After the braking system has checked that no defects that require identification by the red warning signal are present the above message should be set to 00b.
- 4.2.2.3. Response time checking
  - 4.2.2.3.1. Check that, with no faults present, the braking system response time requirements defined in paragraph 3.5.2. of annex 6 to this Regulation are met.
- 4.2.3. Additional checks
  - 4.2.3.1. At the discretion of the Technical Service the checking procedures defined above may be repeated with the non-braking messages relevant to the interface in different states or switched off.

Where repeat measurements of the brake system response time are carried out, variations in the value recorded may occur due to the reaction of the vehicle pneumatics. In all cases the prescribed response time requirements shall be met.

\_\_\_\_\_"  
\_\_\_\_\_