

24 March 1980

AGREEMENT

CONCERNING THE ADOPTION OF UNIFORM CONDITIONS OF APPROVAL AND RECIPROCAL RECOGNITION OF APPROVAL FOR MOTOR VEHICLE EQUIPMENT AND PARTS

done at Geneva on 20 March 1958

Addendum 41: Regulation No. 42

Date of entry into force as an annex to the Agreement
1 June 1980

UNIFORM PROVISIONS CONCERNING THE APPROVAL OF VEHICLES
WITH REGARD TO THEIR FRONT AND REAR PROTECTIVE DEVICES
(BUMPERS, ETC.)



UNITED NATIONS

Regulation No. 42

UNIFORM PROVISIONS CONCERNING THE APPROVAL OF
VEHICLES WITH REGARD TO THEIR FRONT AND REAR PROTECTIVE DEVICES
(BUMPERS, ETC.)

CONTENTS

REGULATION	<u>Pages</u>
1. Scope	1
2. Purpose	1
3. Definitions	1
4. Application for approval	2
5. Approval	3
6. Requirements	4
7. Modification of the vehicle type	5
8. Conformity of production	5
9. Penalties for non-conformity of production	6
10. Production definitely discontinued	6
11. Names and addresses of technical services responsible for conducting approval tests, and administrative departments	6
 ANNEXES	
<u>Annex 1</u> - Communication concerning the approval (or refusal or withdrawal of approval or production definitely discontinued) of a vehicle type with regard to its front and rear protective devices (bumpers, etc.) pursuant to Regulation No. 42.	
<u>Annex 2</u> - Arrangements of approval marks	
<u>Annex 3</u> - Low-speed-impact test procedure	

Regulation No. 42

UNIFORM PROVISIONS CONCERNING THE APPROVAL OF VEHICLES WITH REGARD
TO THEIR FRONT AND REAR PROTECTIVE DEVICES (BUMPERS, ETC.)

1. SCOPE

This Regulation applies to the behaviour of certain parts of the front and rear structure of passenger cars when involved in a collision at low speed.

2. PURPOSE

- 2.1. Exterior protection is assured by protective devices, which are essentially elements located at the front and rear ends of vehicles and designed in such a way as to allow contacts and small shocks to occur without causing any serious damage.

3. DEFINITIONS

- 3.1. For the purpose of this Regulation,

- 3.1.1. "Approval of a vehicle" means the approval of a vehicle type with regard to the behaviour of certain parts of its front and rear structure in the event of a collision at low speed;
- 3.1.2. "Vehicle type" means a category of power-driven vehicles which do not differ in such essential respects as:
- 3.1.2.1. the length and width of the vehicle, and the structure, dimensions, lines and materials of the front and rear parts of the vehicle in so far as they have an effect on the results of the impact test prescribed in this Regulation;
- 3.1.2.2. the siting (front, rear or centre) and weight of the engine;
- 3.1.2.3. the characteristics of the suspension, to the extent that they affect the results of the impact test prescribed in this Regulation;
- 3.1.3. "Unladen weight" means the weight of the vehicle in running order, unoccupied and unladen but complete with fuel, coolant, lubricant, tools and a spare wheel (if provided as standard equipment by the vehicle manufacturer);
- 3.1.4. "Laden test weight" means the weight of the vehicle when it is loaded to the conditions indicated in paragraph 3.1.3. plus the weight of the passengers (taking 75 kg. per passenger) distributed as follows:

Number of seating positions	Number of passengers	Distribution
2 and 3	2	2 in the front seats
4 and 5	3	2 in the front seats 1 in the back seat
6 and 7	4	2 in the front seats 2 in the rearmost seats
8 and 9	5	2 in the front seats 3 in the rearmost seats When the rear row of seats has only two seating positions, one person shall be on the second row from the rear

3.1.5. "Vehicle corner" means the vehicle's point of contact with a tangent vertical plane which makes an angle of 60° with the longitudinal median plane of the vehicle;

3.1.6. "Reference height" means the height above the ground at which the vehicle should embody sufficient protective devices, both at "unladen kerb weight" and at "laden test weight". This reference height is that of the horizontal plane passing through the reference line of the impactor described in paragraph 2.3. of annex 3 to this Regulation;

3.1.7. "Reference line" means a line outside the impactor at the intersection of the horizontal plane of symmetry of the impact contour with the impact contour itself, plane A of the impactor being vertical.

4. APPLICATION FOR APPROVAL

4.1. The application for approval of a vehicle type with regard to the protection afforded by the bumpers in a collision at low speed shall be submitted by the vehicle manufacturer or by his duly accredited representative.

4.2. It shall be accompanied by the undermentioned documents in triplicate and the following particulars:

4.2.1. a detailed description of the vehicle type with respect to its structure, dimensions, lines and constituent materials;

4.2.2. drawings of the vehicle showing the vehicle type in front, side and rear elevation and design details of the forward and rear parts of the structure; and

- 4.2.3. particulars of the vehicle's unladen weight;
- 4.2.4. a detailed description of the protective devices: their dimensions, lines, constituent materials and position on the vehicle.
- 4.3. A vehicle representative of the type to be approved shall be submitted to the technical service responsible for conducting the approval tests.
 - 4.3.1. A vehicle not comprising all the components proper to the type may be accepted for test provided that it can be shown that the absence of the components omitted has no detrimental effect on the results of the test, so far as the requirements of this Regulation are concerned.
 - 4.3.2. It shall be the responsibility of the applicant for approval to show that acceptance of the variants referred to in paragraph 4.3.1. is compatible with compliance with the requirements of this Regulation.
- 5. APPROVAL
 - 5.1. If the vehicle type submitted for approval pursuant to this Regulation meets the requirements of paragraph 6. below, approval of that vehicle type shall be granted.
 - 5.2. An approval number shall be assigned to each type approved. Its first two digits shall indicate the series of amendments incorporating the most recent major technical amendments made to the Regulation at the time of issue of the approval. The same Contracting Party may not assign the same number to another vehicle type.
 - 5.3. Notice of approval or of refusal of approval of a vehicle type pursuant to this Regulation shall be communicated to the Parties to the Agreement which apply this Regulation by means of a form conforming to the model in annex 1 to this Regulation and of dimensioned drawings of the vehicle structure supplied by the applicant for approval in a format not exceeding A4 (210 x 297 mm) or folded to that format and on an appropriate scale.
 - 5.4. There shall be affixed, conspicuously and in a readily accessible place specified on the approval form, to every vehicle conforming to a vehicle type approved under this Regulation an international approval mark consisting of:

- 5.4.1. a circle surrounding the letter "E" followed by the distinguishing number of the country which has granted approval 1/ ,
- 5.4.2. the number of this Regulation, followed by the letter "R", a dash and the approval number to the right of the circle prescribed in paragraph 5.4.1.
- 5.5. If the vehicle conforms to a vehicle type approved, under one or more other Regulations annexed to the Agreement in the country which has granted approval under this Regulation, the symbol prescribed in paragraph 5.4.1. need not be repeated; in such a case the Regulation and approval numbers and the additional symbols of all the Regulations under which approval has been granted in the country which has granted approval under this Regulation shall be placed in vertical columns to the right of the symbol prescribed in paragraph 5.4.1.
- 5.6. The approval mark shall be clearly legible and be indelible.
- 5.7. The approval mark shall be placed close to or on the vehicle data plate affixed by the manufacturer.
- 5.8. Annex 2 to this Regulation gives examples of arrangements of the approval mark.

6. REQUIREMENTS

- 6.1. Surfaces of protective devices at the front and rear end of the vehicle which are most likely to come into contact with other objects shall be covered by, or made of rubber, or equivalent material, the hardness of which shall not exceed 60 Shore A.
- 6.2. After each impact test made in accordance with the conditions and procedure specified in annex 3 to this Regulation, the vehicle shall meet the following requirements:

1/ 1 for the Federal Republic of Germany, 2 for France, 3 for Italy, 4 for the Netherlands, 5 for Sweden, 6 for Belgium, 7 for Hungary, 8 for Czechoslovakia, 9 for Spain, 10 for Yugoslavia, 11 for the United Kingdom, 12 for Austria, 13 for Luxembourg, 14 for Switzerland, 15 for the German Democratic Republic, 16 for Norway, 17 for Finland, 18 for Denmark, 19 for Romania, 20 for Poland and 21 for Portugal; subsequent numbers shall be assigned to other countries in the chronological order in which they ratify the Agreement concerning the Adoption of Uniform Conditions of Approval and Reciprocal Recognition of Approval for Motor Vehicle Equipment and Parts, or in which they accede to that Agreement, and the numbers thus assigned shall be communicated by the Secretary-General of the United Nations to the Contracting Parties to the Agreement.

- 6.2.1. The lighting and signalling devices shall continue to operate correctly and to remain visible. Should the adjustment of the factory-fitted lighting devices be disturbed, it may be corrected to conform to the required specifications, provided this can be done by the normal means of adjustment. Bulbs may be replaced in the event of filament failure.
- 6.2.2. The vehicle's bonnet (hood), boot lid (trunk lid) and doors shall be operable in the normal manner; in addition, the side doors of the vehicle shall not be able to open under the effect of the impact.
- 6.2.3. The vehicle's fuel and cooling systems shall have neither leaks nor constricted fluid passages which prevent normal functioning; their sealing devices and caps shall be operable in the normal manner.
- 6.2.4. The vehicle's exhaust system shall not suffer any damage or displacement which would prevent its normal function.
- 6.2.5. The vehicle's propulsion, suspension (including tyres), steering and braking systems shall remain in adjustment and shall operate in a normal manner.

7. MODIFICATIONS OF VEHICLE TYPE

- 7.1. Every modification of the vehicle type shall be notified to the administrative department which approved the vehicle type. The department may then either:
 - 7.1.1. consider that the modifications made are unlikely to have appreciable adverse effects, and that in any case the vehicle still complies with the requirements; or
 - 7.1.2. require a further test report from the technical service responsible for conducting the tests.
- 7.2. Confirmation or refusal of approval, specifying the alterations, shall be communicated by the procedure specified in paragraph 5.3. above to the Parties to the Agreement which apply this Regulation.

8. CONFORMITY OF PRODUCTION

- 8.1. Every vehicle bearing an approval mark as prescribed under this Regulation shall conform to the vehicle type approved, particularly as regards features which influence the behaviour of the parts of the structure and the components affected by impact.
- 8.2. In order to verify conformity as prescribed in paragraph 8.1. above, a sufficient number of random checks shall be made on serially-manufactured vehicles bearing the approval mark required by this Regulation.

8.3. As a general rule, the said checks shall be confined to measurements. However, the vehicles shall, if necessary, be subjected to the checks prescribed in paragraph 6. above.

9. PENALTIES FOR NON-CONFORMITY OF PRODUCTION

9.1. The approval granted in respect of a vehicle type pursuant to this Regulation may be withdrawn if the requirement laid down in paragraph 8.1. above is not complied with or if the vehicle has failed to pass the tests prescribed in paragraph 6. above.

9.2. If a Party to the Agreement which applies this Regulation withdraws an approval it has previously granted, it shall forthwith so notify the other Contracting Parties to the Agreement which apply this Regulation, by means of a copy of the approval form bearing at the end, in large letters, the signed and dated annotation "APPROVAL WITHDRAWN".

10. PRODUCTION DEFINITELY DISCONTINUED

If the holder of the approval completely ceases production of a vehicle approved in accordance with this Regulation, he shall so inform the authority which granted the approval. Upon receiving the relevant communication, that authority shall inform thereof the other Parties to the Agreement applying this Regulation, by means of a copy of the approval form bearing at the end, in large letters, the signed and dated annotation "PRODUCTION DISCONTINUED".

11. NAMES AND ADDRESSES OF TECHNICAL SERVICES RESPONSIBLE FOR CONDUCTING APPROVAL TESTS, AND OF ADMINISTRATIVE DEPARTMENTS

The Parties to the Agreement which apply this Regulation shall communicate to the United Nations Secretariat the names and addresses of the technical services responsible for conducting approval tests and of the administrative departments which grant approval and to which forms certifying approval or refusal or withdrawal of approval, issued in other countries, are to be sent.

Annex 1

(Maximum format: A 4(210 x 297 mm))



Name of the Administration

Communication concerning the approval (or refusal or withdrawal of approval or production definitely discontinued) of a vehicle type with regard to its front and rear protective devices (bumpers, etc.), pursuant to Regulation No. 42

Approval No.

1. Trade name or mark of the power-driven vehicle
2. Vehicle type
3. Manufacturer's name and address
4. If applicable, name and address of manufacturer's representative
5. Brief description of the vehicle type as regards its structure, suspension, dimensions, lines and constituent materials
6. Brief description of the protective devices as regards their lines, dimensions and constituent materials
7. Weight and siting of engine
8. Weight of vehicle when tested

	unladen	laden
front axle:
rear axle:
total:

9. Indication of impact speeds and masses
10. Vehicle submitted for approval on
11. Technical service responsible for conducting approval tests
12. Date of report issued by that service
13. Number of report issued by that service

14. Approval granted/refused */
15. Position of approval mark on the vehicle
16. Place
17. Date
18. Signature
19. The following documents, bearing the approval number shown above, are annexed to this communication:
 - ... drawings, diagrams and lay-out plans of the components of the structure considered to be of importance for the purposes of this Regulation,
 - ... drawings of the protective devices and their position on the vehicle.

*/ Strike out whatever does not apply.

Annex 2

ARRANGEMENTS OF APPROVAL MARKS

Model A

(See paragraph 5.4. of this Regulation)

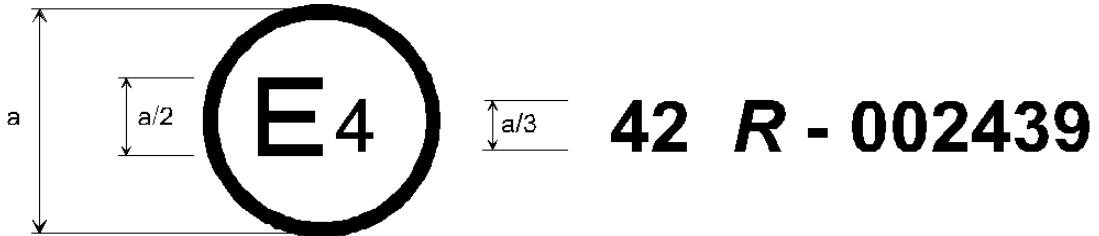

$a = 8 \text{ mm min}$

The above approval mark affixed to a vehicle shows that the vehicle type concerned has, with regard to its front and rear protective devices (bumpers, etc.), been approved in the Netherlands (E 4) pursuant to Regulation No. 42. The approval number indicates that the approval was granted in accordance with the requirements of Regulation No. 42 in its original form.

Model B

(See paragraph 5.5. of this Regulation)

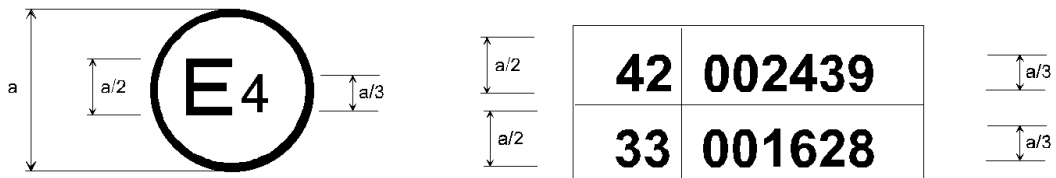

$a = 8 \text{ mm min}$

The above approval mark affixed to a vehicle shows that the vehicle type concerned has been approved in the Netherlands (E 4) pursuant to Regulations Nos. 42 and 33.*/ The approval numbers indicate that, at the dates when the respective approvals were given, Regulations Nos. 40 and 33 were still in their original form.

 */ The latter number is given as an example only.

Annex 3

LOW-SPEED-IMPACT TEST PROCEDURE

1. SCOPE AND PURPOSE

The purpose of this test is to simulate frontal and rearward low-speed-impact conditions with another vehicle. The test shall make it possible to verify whether the protective devices of the vehicle meet the requirements of this Regulation.

2. INSTALLATIONS, PROCEDURES AND MEASURING INSTRUMENTS

2.1. Testing ground

The test area shall be large enough to accommodate the impactor (striker) propulsion system and to permit after-impact displacement of the vehicle impacted and installation of the test equipment. The vehicle shall be placed on a horizontal and level rigid smooth surface.

2.2. State of the vehicle

2.2.1. The vehicle shall be at rest.

2.2.2. The front wheels shall be in the straight-ahead position.

2.2.3. The tyres shall be inflated to the pressure recommended by the vehicle manufacturer.

2.2.4. The brakes shall be disengaged and the transmission control shall be in neutral position.

2.2.5. Vehicles equipped with hydro pneumatic, hydraulic or pneumatic suspension or a device for automatic levelling according to load shall be tested in the normal running conditions specified by the manufacturer.

2.3. Impactor (striker)

2.3.1. The impactor shall be of rigid construction, the impact contour being of hardened steel.

2.3.2. The impacting surface shall conform to the diagram in the figure.

2.3.3. The effective mass shall be equal to the mass corresponding to the "unladen weight" of the vehicle to be tested.

2.3.4. With plane A of the impactor vertical, the reference line shall be horizontal.

- 2.3.5. The first contact of the impactor with the vehicle shall be by the impact contour on the protective device. In the two vehicle-loading conditions the protective device between the corners, as defined in paragraph 3.1.5. of this Regulation, shall be intersected by the horizontal plane passing through the reference line.
- 2.3.6. The reference height is 445 mm.
- 2.4. Propulsion of the impactor
The impactor may either be secured to a carriage (moving barrier) or form part of a pendulum.
- 2.5. Special provisions applicable where a moving barrier is used
- 2.5.1. If the impactor is secured to a carriage (moving barrier) by a restraining element, the latter must be rigid and be incapable of being deformed by the impact; the carriage shall at the moment of impact be capable of moving freely and no longer be subject to the action of the propelling device.
- 2.6. Special provisions applicable where a pendulum is used
- 2.6.1. The distance between the pivot and the centre of percussion shall be at least 3.3 m. The reference line shall coincide with the centre of percussion.
- 2.6.2. Plane A of the pendulum shall remain parallel with its axis of rotation throughout the test.
- 2.6.3. In the case of a parallelogram-suspended pendulum, the trajectory described by any point on the reference line shall be constant with a radius of at least 3.3 m.
- 2.7. Longitudinal impact test
- 2.7.1. This test consists of two impacts on the front surface and two impacts on the rear surface of the vehicle. On each surface one impact is made with the vehicle under "unladen weight", as defined in paragraph 3.1.3. of this Regulation, and the other is made with the vehicle under "laden test weight", as defined in paragraph 3.1.4.
- 2.7.2. For the impacts on the front and rear surfaces, the choice of location of the impactor for the first impact is free, but for the second impact the median plane of the impactor shall be at a distance at least 300 mm from the first, provided that during these impacts the extremities of the impactor do not pass outside a zone defined by two planes parallel to the longitudinal median plane and passing through the corners of the vehicle.
- 2.7.3. The impactor shown in the figure should be placed so that plane A is vertical and the reference line is horizontal at the reference height of 445 mm.

- 2.7.4. The vehicle should be aligned so that a point between the vehicle corners touches, but does not move, the impactor, the longitudinal median plane of the vehicle being perpendicular to plane A of the impactor.
- 2.7.5. The vehicle should be impacted at a speed of 4 km/h $\begin{matrix} +0.25 \\ -0 \end{matrix}$
- 2.8. Corner impact test
- 2.8.1. This test consists of an impact at one front corner and an impact at one rear corner of the vehicle, which is at unladen weight (see paragraph 3.1.3. of the Regulation), and an impact at the other front corner and the other rear corner with the vehicle at the weight given in paragraph 3.1.4.
- 2.8.2. The impactor shown in the figure should be placed so that plane A is vertical and the reference line is horizontal and at the reference height of 445 mm.
- 2.8.3. The vehicle should be aligned so that a corner of the vehicle touches the impactor without moving it. In addition the following conditions shall be met:
- (a) plane A of the impactor shall make an angle of $60 \pm 5^\circ$ with the longitudinal median plane of the vehicle;
 - (b) the point of the first contact shall be in the vertical median plane of the impactor (within a tolerance of ± 25 mm).
- 2.8.4. The vehicle should be impacted at a speed of 2.5 km/h $\begin{matrix} +0.1 \\ -0 \end{matrix}$
3. CONDITIONS GOVERNING REPAIR, REPLACEMENT AND MEASUREMENT
- 3.1. The protective devices and the mountings attaching them to the vehicle structure may be repaired or replaced between the tests.
- 3.2. If the protective devices include self-restoring materials, the permitted recovery time between tests shall be as stated by the manufacturer.
- 3.3. If the manufacturer so requests, a vehicle of the same type may be used for each test.
- 3.4. If the manufacturer so requests, the technical service responsible for conducting the tests may allow the same vehicle as is used for tests prescribed by other Regulations (including tests capable of affecting its structure) to be used also for the tests prescribed by this Regulation.

3.5 If the test has been carried out at an impact speed or with an impact mass exceeding those indicated in paragraphs 2.7.5. and 2.8.4. above, and the vehicle has satisfied the conditions prescribed, the test is considered satisfactory.

3.6. Measuring instruments

The instrument used to record the speed referred to in paragraphs 2.7.5. and 2.8.4. above shall be accurate to within one per cent.

4. EQUIVALENT TEST METHODS

4.1. Other equivalent test methods are permitted provided that the conditions referred to in this Regulation can be observed and that their equivalence can be demonstrated.

Dimensions in millimetres

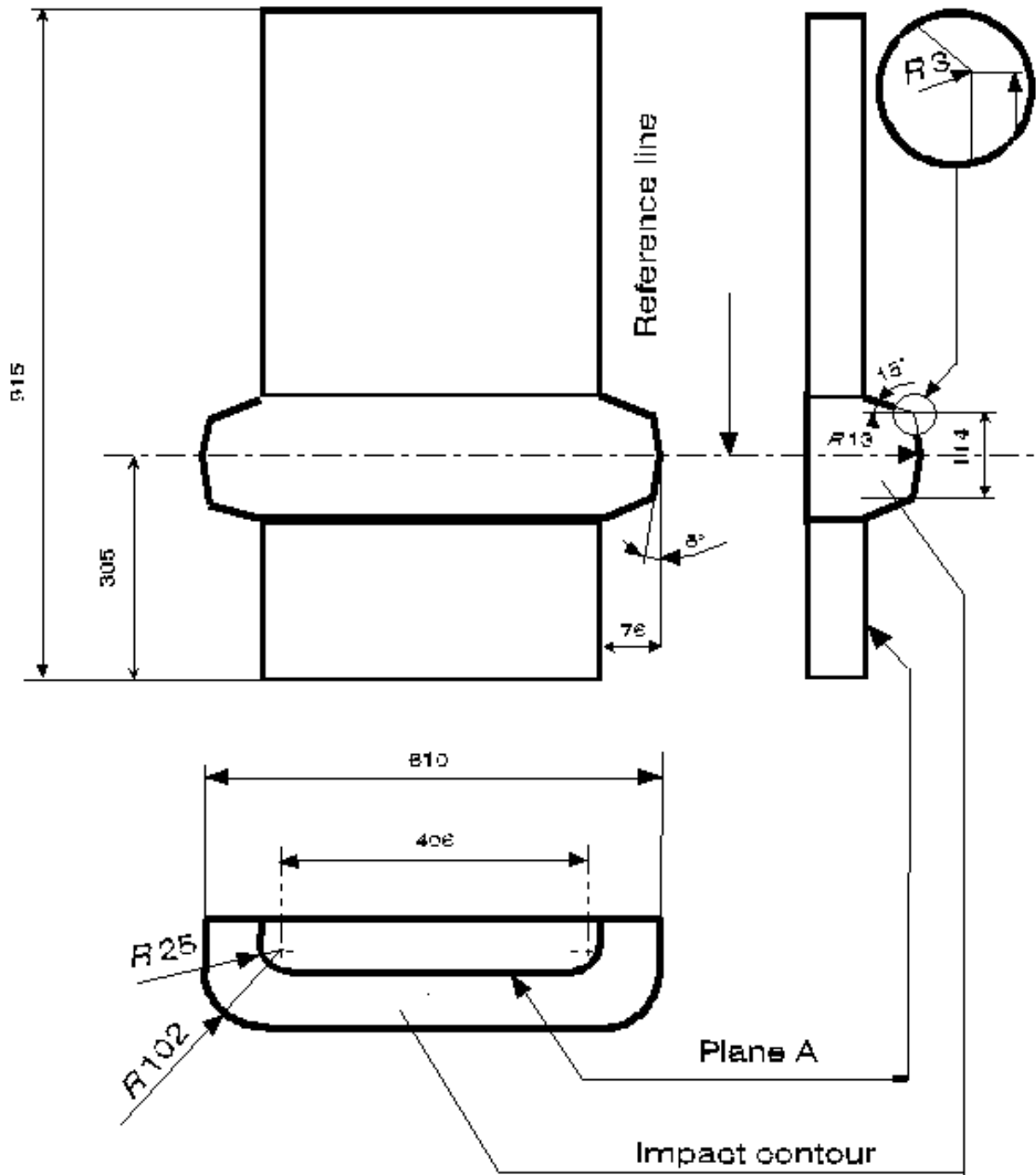

Figure - Impact device
