

ECONOMIC COMMISSION FOR EUROPE

INLAND TRANSPORT COMMITTEE

Working Party on Inland Water Transport

Recommendation on Electronic Chart Display and Information System for Inland Navigation (Inland ECDIS)

Resolution No. 48

Revision 4



UNITED NATIONS
New York and Geneva, 2020

Introduction

The fourth revision of the Recommendation on electronic chart display and information system for inland navigation (annex to resolution No. 48) has been prepared by the Chair of the International Inland ECDIS Expert Group in cooperation with the secretariat, based on edition 2.4 of the Inland ECDIS Standard and additional amendments finalized in 2018, introduced by Commission Implementing Regulation (EU) 2018/1973 of 7 December 2018 amending Implementing Regulation No. 909/2013 on the technical specifications for the electronic chart display and information system for inland navigation (Inland ECDIS) referred to in Directive 2005/44/EC of the European Parliament and of the Council.

The present revision was preliminarily approved by the Working Party on the Standardization of Technical and Safety Requirements in Inland Navigation (SC.3/WP.3) at its fifty-fourth and fifty-fifth sessions and adopted by the Working Party on Inland Water Transport (SC.3) at its sixty-third session (6 to 8 November 2019).

Recommendation on Electronic Chart Display and Information System for Inland Navigation (Inland ECDIS)

Resolution No. 48

(adopted by the Working Party on Inland Water Transport on 25 October 2001)

The Working Party on Inland Water Transport,

Noting the development of electronic charts for inland navigation and the necessity to have a harmonized standard for these charts in Europe to enable international transport to use charts of different countries with the same equipment of hardware and software,

Bearing in mind the existing standard of IHO and IMO for Electronic Chart Display and Information Systems (S-52 and S-57) for maritime navigation and the desirability of compatibility in areas of mixed traffic, where inland navigation as well as seagoing vessels are navigating,

Recommends Governments, intergovernmental organizations, regional economic integration organizations, river commissions and private entities to apply the Inland ECDIS Standard reproduced in the annex to this resolution for the production of electronic charts for inland navigation,

Recommends Governments to bring their national legislation concerning navigation by inland waterway in accordance with the Inland ECDIS Standard,

Invites Governments to keep the secretariat informed of the measures taken with a view to the introduction of the Inland ECDIS Standard, specifying the inland waterways concerned,

Requests the Executive Secretary of the Economic Commission for Europe to periodically include the question of application of this resolution in the agenda of the Working Party on Inland Water Transport.

Amendments to the Recommendation on Electronic Chart Display and Information System for Inland Navigation (Inland ECDIS)

Resolution No. 96

(adopted by the Working Party on Inland Water Transport on 8 November 2019)

The Working Party on Inland Water Transport,

Noting the progress reached in the development of electronic charts for inland navigation and the necessity to have a harmonized standard for these charts in Europe to enable international transport to use charts of different countries with the same equipment of hardware and software,

Responding to the Policy Recommendation No. 3 of the UNECE White Paper on Efficient and Sustainable Inland Water Transport in Europe (ECE/TRANS/SC.3/189), the strategic recommendations set out in the Wroclaw Declaration and resolution No. 265 of 22 February 2019 of the Inland Transport Committee,

Bearing in mind the existing standard of IHO and IMO for Electronic Chart Display and Information Systems (S-52 and S-57) for maritime navigation and the desirability of compatibility in areas of mixed traffic, where inland navigation as well as seagoing vessels are navigating,

Bearing in mind also the ongoing work by the European Commission and the European Committee for drawing up Standards in the field of Inland Navigation (CESNI),

Taking into account resolution No. 48, revision 3, "Recommendation on Electronic Chart Display and Information System for Inland Navigation (Inland ECDIS)" (ECE/TRANS/SC.3/156/Rev.3) adopted by resolution No. 84 of the Working Party on Inland Water Transport on 11 November 2015,

Taking into account also the report of the Working Party on the Standardization of Technical and Safety Requirements in Inland Navigation of its fifty-fifth session (ECE/TRANS/SC.3/WP.3/110, para. 79),

Recalling the procedure of any further amendment of resolution No. 48 and its technical appendices established by resolution No. 77 and adopted by the Working Party on Inland Water Transport on 12 October 2012,

1. *Decides* to replace the text of the annex to resolution No. 48, revision 3, with the text contained in the annex to this resolution,

2. *Recommends* Governments, intergovernmental organizations, regional economic integration organizations, river commissions and private entities to apply the Inland ECDIS Standard reproduced in the annex to this resolution for the production of electronic charts for inland navigation,

3. *Recommends* Governments to bring their national legislation concerning navigation by inland waterway in accordance with the Inland ECDIS Standard,

4. *Invites* Governments to keep the secretariat informed of the measures taken with a view to the introduction of the Inland ECDIS Standard, specifying the inland waterways concerned,

5. *Requests* the Executive Secretary of the Economic Commission for Europe to periodically include the question of application of this resolution in the agenda of the Working Party on Inland Water Transport.

Annex**Recommendation on Electronic Chart Display and Information System for Inland Navigation (Inland ECDIS)****Contents**

	<i>page</i>
Part A. Preface	6
Part B. Structure of the technical specifications for Inland ECDIS (Edition 2.4)	8
Part C. Technical Specifications for Electronic Chart Display and Information System for Inland Navigation (Inland ECDIS) (Edition 2.4)	9
Section 1: Performance Standard for Inland ECDIS	9
Section 2: Data Standard for Inland ENC's	20
Section 2A: Codes for Producers and Waterways (in addition to IHO-S-62 ENC Producer Codes)	21
Section 3: Presentation Standard for Inland ECDIS	25
Section 4: Operational and Performance Requirements, Methods of Testing and Required Test Results	28
Section 4A: Measures to ensure Software Quality	39
Section 4B: System Configurations (Figures)	43
Section 5: Glossary of Terms	45
Appendix 1.0 Product Specification for Inland ENC's:	
• Appendix 1.0. Product Specification for Inland ENC's Edition 2.4 1.0	
• Appendix 1.1. IENC Feature Catalogue Edition 2.4 Corr.2, 30 October 2015	
• Appendix 1.2. Encoding Guide for Inland ENC's. Edition 2.4, 30 October 2015	
Appendix 2. Status of the Presentation Library for Inland ECDIS:	
• Appendix 2.0. Presentation Library for Inland ECDIS 2.4	
• Appendix 2.1. Look Up Tables 2.4	
• Appendix 2.2. IES Symbols 2.4	
Appendix 3. Product Specification for Bathymetric Inland ENC's:	
• Appendix 3.0. Product Specification for Bathymetric Inland ENC's	
• Appendix 3.1. Feature Catalogue for Bathymetric Inland ENC's Edition 1.0	
Appendix 4. Comparison of the structures of the standard for (Maritime) ECDIS and of the technical specifications for Inland ECDIS	50

Note: Appendices 1–3 are available in electronic format in English only at www.unece.org/trans/main/sc3/sc3res.html.

Part A. Preface

1. Since the late 1990s, reflections and experiments using telematics for the support of inland navigation have been made in several member States of the United Nations Economic Commission for Europe (ECE). In different research and development projects, the radar image on the display in the wheelhouse was underlaid by an electronic chart. This is a safer and more efficient approach of inland navigation.

2. The discussions established that only an internationally agreed upon procedure would be successful, since a skipper could not be expected to employ different equipment in each country. Thus, the internationally introduced and very mature Electronic Chart Display and Information System (ECDIS) – originally developed for maritime navigation – was also considered for inland navigation. The idea was to adopt ECDIS for inland navigation and to supplement some distinct inland features, but not to change the original ECDIS standard. In this way, compatibility was possible between the original – Maritime – ECDIS and Inland ECDIS. This is important for the estuaries of the rivers, where sea vessels as well as inland vessels navigate.

3. In 1998, the European Union appointed an International Inland ECDIS Expert Group (Expert Group) for the development of an Inland ECDIS Standard. The Expert Group submitted its first proposal on 1 January 1999.

4. In 2000, the Central Commission for the Navigation of the Rhine (CCNR) installed an Ad-hoc Working Group for Inland ECDIS with the order to draft the Inland ECDIS Standard of CCNR.

5. The Ad-hoc Working Group took the results of the Expert Group as the basis for their further work and developed edition 1.0 of the Inland ECDIS Standard. The Inland ECDIS Standard has been adopted not only by CCNR, but also by the Danube Commission, ECE and the World Association for Waterborne Transport Infrastructure (PIANC). The standard has become the first in inland navigation to have been recognized by all these organizations.

6. For ECE, the Inland ECDIS Standard was adopted by resolution No. 48, “Recommendation on Electronic Chart Display and Information System for Inland Navigation (Inland ECDIS)” (TRANS/SC.3/156), approved by the Working Party on Inland Water Transport (SC.3) on 25 October 2001. In this resolution, SC.3 recommended that Governments, intergovernmental organizations, regional economic integration organizations, river commissions and private entities apply the Inland ECDIS Standard for producing electronic charts for inland navigation. It also recommended Governments to bring their national inland waterway navigation legislation in accordance with the standard.

7. Further development by the Expert Group of the standard into edition 2.0 was driven by several aspects:

(a) The European Union’s research and development project COMPRIS (Consortium Operational Management Platform River Information Services) further developed the Inland ECDIS Standard its applications. These developments have been focused on the information side of Inland ECDIS with special regard to voyage planning;

(b) As the Inland ECDIS Standard had not been officially recognized by the International Hydrographic Organization (IHO) in the beginning, there were some incompatibilities between edition 3.1 of IHO Special Publication No. S-57, “IHO Transfer Standard for Digital Hydrographic Data” and the initial Inland ECDIS Standard. In order to ensure the future compatibility of Inland ECDIS and S-57 and its foreseen successors S-100 and S-101, it was necessary to obtain recognition by IHO. Therefore, an international harmonization group with the participation of the Russian Federation, the United States of America (US) and several countries from South America and Asia was set up to get a better basis for a worldwide recognition of Inland ECDIS. The Inland ENC Harmonization Group (IEHG) was mandated as a task force of the Expert Group. IEHG developed an Inland ENC Encoding Guide on the basis of a similar document of the US Army Corps of Engineers (USACE). This document was amended with the additional features and attributes of the European approach. Whenever possible, the American approach of using pure S-57 to encode the same real-world entities was applied. All the amendments of COMPRIS and the

harmonization process were introduced in the documents of the Inland ECDIS standard by the Expert Group. IEHG has been recognized as a Non-Governmental International Organization (NGIO) by IHO in 2009. An Inland ENC Domain has been implemented by IEHG within the S-100 registry of IHO;

(c) Directive 2005/44/EC of the European Parliament and of the Council of 7 September 2005 on harmonized river information services (RIS) on inland waterways in the Community required the adoption of a technical specification in the area of Inland ECDIS.

8. The Expert Group had delivered its proposal for edition 2.0 in June 2006 to the relevant international organizations for adoption. Based on this proposal from the Expert Group, SC.3 at its fiftieth session decided to update its resolution No. 48 accordingly (ECE/TRANS/SC.3/174, para. 50). The first revised edition of the resolution was issued by ECE in 2007 (ECE/TRANS/SC.3/156/Rev.1).

9. In February 2011, the Chair of the Expert Group informed SC.3 about an updated edition of the Inland ECDIS Standard (edition 2.3). Edition 2.3 was also transmitted by the Expert Group to the River Information Services (RIS) Committee of the European Union, which approved the proposal to use it for the Commission Regulation on Inland ECDIS within the framework of Directive 2005/44/EC. The work on the second revised edition of resolution No. 48 was, thus, initiated by ECE in 2011. During this revision, the term “Inland ECDIS Standard” was replaced by “Technical specifications for Inland ECDIS”. The second revision of the resolution was adopted by the fifty-sixth session of SC.3 on 12 October 2012 as resolution No. 77.

10. The diagram in Part B and the comparison table of the structures of the standard for (Maritime) ECDIS and of the technical specifications for Inland ECDIS in appendix 4 show the structure of the Inland ECDIS and the mapping between (maritime) ECDIS and the technical specifications for Inland ECDIS, edition 2.4.

11. The Expert Group started working on edition 2.4 of the Inland ECDIS Standard in 2011. IEHG and the Inland ECDIS Expert Group adopted edition 2.4 in 2015 and forwarded this to the European Commission and ECE. The third revision of resolution No. 48 was adopted by the fifty-ninth session of SC.3 on 11 November 2015 as resolution No. 84. According to the new internal rules, the European Commission started a “Better Wording” procedure with the aim to make technical standards more clear and better to understand. It required additional amendments to the newly adopted edition 2.4, and also to the third revision of resolution No. 48, however, no substantial changes were necessary. This work was finalized in 2018. The revised Inland ECDIS standard edition 2.4 was introduced by Commission Implementing Regulation (EU) 2018/1973 of 7 December 2018 amending Implementing Regulation No. 909/2013 on the technical specifications for the electronic chart display and information system for inland navigation (Inland ECDIS) referred to in Directive 2005/44/EC of the European Parliament and of the Council.

12. In February 2019, the Chair of the Expert Group prepared an amendment proposal to resolution No. 48, revision 3, for consideration by the fifty-fourth and fifty-fifth sessions of the Working Party on the Standardization of Technical and Safety Requirements in Inland Navigation (SC.3/WP.3), which was finalized and adopted by SC.3 as resolution No. 48, revision 4, on 8 November 2019 at its sixty-third session.

13. Technical appendices to the Inland ECDIS Standard established by the Expert Group can be consulted in English at the website of SC.3: www.unece.org/trans/main/sc3/sc3res.html.

Part B. Structure of the technical specifications for Inland ECDIS (Edition 2.4)

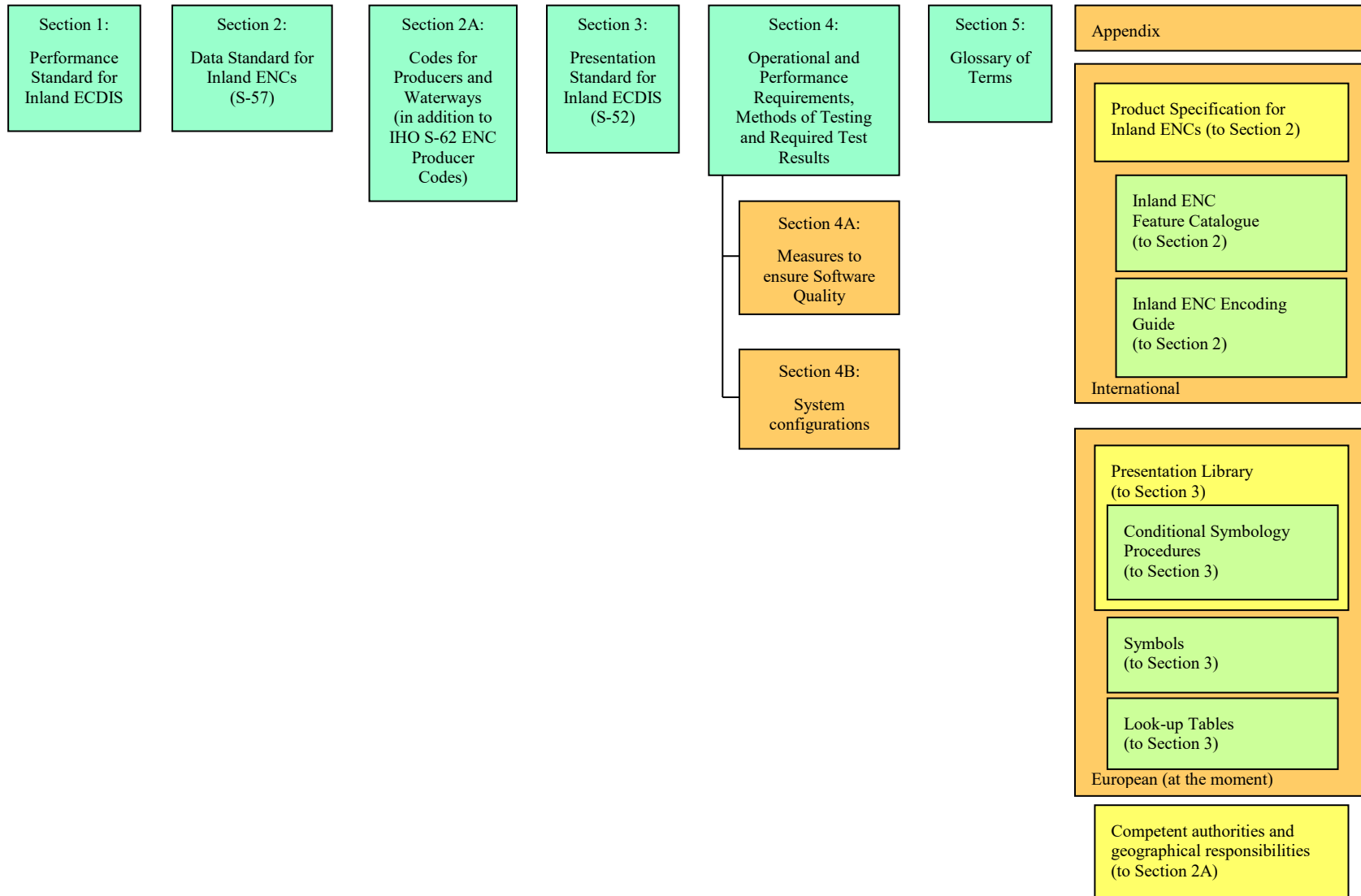

Part C. Technical Specifications for Electronic Chart Display and Information System for Inland Navigation (Inland ECDIS) (Edition 2.4)

Section 1: Performance Standard for Inland ECDIS

1. General Provisions

(a) Electronic chart display and information system for inland navigation (Inland ECDIS) is composed of hardware, software for the operating system and application software;

(b) Inland ECDIS aims to contribute-to safety and efficiency of inland shipping;

(c) Inland ECDIS can be designed for both **information mode** and **navigation mode**-or for **information mode** only.

The minimum requirements for Inland ECDIS equipment designed for **information mode only**, specified in chapter 4.1 of section 1 and section 4 of this annex, are mandatory on waterways where carriage requirements are enacted by the responsible legislative organs. In other regions they are recommended;

(d) For **navigation mode**, Inland ECDIS (Operating System Software, Application Software and Hardware), as specified in section 4 of this annex, shall have a high level of reliability and availability; at least of the same level as other means of navigation;

(e) Inland ECDIS shall use chart information as specified in sections 2 and 3 of this annex;

(f) National authorities and international bodies are recommended to consider transitional provisions when they are introducing carriage requirements for Inland ECDIS;

(g) Inland ECDIS shall meet all the requirements of the Inland ECDIS performance standard set out in this annex;

(h) The terms “skipper” and “boatmaster” used in this annex shall be deemed to be equivalent with the term “ship master” used in the Guidelines and recommendations for River Information Services (resolution No. 57) and RIS Guidelines — Commission Regulation (EC) No. 414/2007;¹

(i) The producer or supplier of Inland ECDIS software must document in the user manual of the software which requirements for equipment (hardware) referred to in IHO Special Publication S-52, “Specifications for Chart Content and Display Aspects of ECDIS”, 6th Edition, March 2010, need to be fulfilled for Inland ECDIS in information mode on waterways where carriage requirements are enacted by the responsible legislative organs;

(j) AIS is an automatic identification system for maritime vessels that complies with IMO Resolution MSC.74(69), Annex 3, and Recommendation ITU-R M.1371. Inland AIS refers to the automatic identification system for inland waterway vessels as set out in the International Standard for Tracking and Tracing on Inland Waterways (VTT) (resolution No. 63 and Commission Implementing Regulation (EU) 2019/838 of 20 February 2019²). Inland AIS in Europe applies the same parameters and message structure as AIS Class A mobile stations according to IMO requirements, however, it extends the information content according to the inland navigation requirements. In view of their shared information content,

¹ Commission Regulation (EC) No. 414/2007 of 13 March 2007 concerning the technical guidelines for the planning, implementation and operational use of river information services (RIS) referred to in Article 5 of Directive 2005/44/EC of the European Parliament and of the Council on harmonized river information services (RIS) on inland waterways in the Community (OJ L 105, 23.4.2007, p. 1).

² Commission Implementing Regulation (EU) 2019/838 of 20 February 2019 on technical specifications for vessel tracking and tracing systems and repealing Regulation (EC) No 415/2007 (OJ L 138, 24.5.2019, p. 31–69).

Inland AIS and maritime AIS are compatible. In this annex, whenever AIS is mentioned, it refers to both maritime AIS and Inland AIS, unless specified otherwise.

2. References

(a) IHO Special Publication No. S-57, “IHO Transfer Standard for Digital Hydrographic Data”, Edition 3.1, Supplement No. 2, June 2009 with all appendices and annexes (hereafter S-57);

(b) IHO Special Publication No. S-62, “ENC Producer Codes”, Edition 2.5, December 2009 (hereafter S-62);

(c) IHO Special Publication No. S-52, “Specifications for Chart Content and Display Aspects of ECDIS”, 6th Edition, March 2010 (hereafter S-52), with all appendices and annexes, including

- S-52 Appendix 1 “Guidance on Updating the Electronic Navigational Chart”, Edition 4.0, April 2012
- Former S-52 Appendix 2 "Colours and Symbols Specifications", Edition 4.3 (January 2008)
- Former S-52 Appendix 3 "Glossary of ECDIS-related Terms Specifications" (now S-32, Appendix 1 (September 2007))
- Annex A to former S-52, Appendix 2, "Presentation Library", Edition 3.4 (2008);

(d) IMO Resolution MSC.232(82) “Revised Performance Standards for Electronic Chart Display and Information Systems (ECDIS)”, December 2006, Appendix 3 “Navigational elements and parameters”

(e) International Standard IEC 61174, edition 3.0 “Maritime navigation and radiocommunication equipment and systems – Electronic chart display and information system (ECDIS) – Operational and performance requirements, methods of testing and required test results”, 2008;

(f) Annex 5, Sections I to III of the European Standard laying down Technical Requirements for Inland Navigation vessels Edition 2019 (ES-TRIN 2019): Requirements applicable to radar installations and rate-of-turn indicators;

(g) IHO Special Publication S-32, Appendix 1 “Hydrographic Dictionary — Glossary of ECDIS-related Terms”;

(h) IEC 60945 (2002) and Corr.1 (2008): Marine navigational equipment; General requirements — Methods of testing and required test results;

(i) Resolution No. 61, revision 2, “Recommendations on Harmonized Europe-Wide Technical Requirements for Inland Navigation Vessels”, Appendix 7, Part III “General technical specifications applicable to radar equipment” (ECE/TRANS/SC.3/172/Rev.2);

(j) International standard IEC 61162, “Maritime navigation and radiocommunication equipment and systems — Digital interfaces”;

(k) IENC Domain in the S-100 Geospatial Information Registry;

(l) IEHG Product Specification for Inland ENCs;

(m) IEHG Inland ENC Feature Catalogue;

(n) International Standard for Tracking and Tracing on Inland Waterways (VTT) (resolution No. 63);

(o) Annex II of Directive 2016/1629 of the European Parliament and of the Council of 14 September 2016 laying down technical requirements for inland waterway vessels;

(p) Resolution No. 57, revised, “Guidelines and Recommendations for River Information Services” (ECE/TRANS/SC.3/165/Rev.1);

(q) European Standard EN 302 194-1:2006 “Electromagnetic compatibility and Radio spectrum Matters (ERM); Navigational radar used on inland waterways: Part 1: Technical characteristics and methods of measurement”.

3. Contents, Provision and Updating of Chart Information

3.1 Contents and Provision of Inland Electronic Navigational Charts (Inland ENC) and Bathymetric Inland ENC

(a) The chart information to be used in Inland ECDIS shall be the latest edition of information;

(b) Provisions shall be made to prevent the user from altering the contents of original Inland ENC and bathymetric Inland ENC editions;

(c) At least the following features shall be included in the Inland ENC:

- waterway axis with kilometres and hectometres or miles indication
- links to the external xml-files with operation times of restricting structures, in particular, locks and bridges
- location of ports and transshipment sites
- reference data for water level gauges relevant to navigation
- bank of waterway (at mean water level)
- shoreline construction (e.g. groyne, longitudinal control dam, training wall — any facility that is considered a hazard to navigation)
- contours of locks and dams
- boundaries of the fairway/navigation channel (if defined)
- isolated dangers in the fairway/navigation channel under water
- isolated dangers in the fairway/navigation channel above water level, such as bridges, overhead cables etc.
- official aids-to-navigation (e.g. buoys, beacons, lights, notice marks).

If the chart producer is using overlay files or bathymetric Inland ENC, the features may be included in different cells, but the whole package must fulfil the minimum requirements listed in the indents above;

(d) Where the chart is intended to be used for **navigation mode** (chapter 5.2 of this section), the respective competent authority shall decide for each waterway or harbour which of the features referred to in subparagraph (c) are to be verified. After verification, the respective competent authority shall declare which Inland ENC and bathymetric Inland ENC are approved for **navigation mode** within its geographical area of responsibility (for details, see section 2A of this annex);

(e) The System Electronic Navigational Chart (SENC) shall be stored in the Inland ECDIS.

3.2 Updates

(a) Inland ECDIS shall be capable of accepting updates to the Inland ENC data provided in conformity with the Product Specification for Inland ENC and updates of the depth information provided in conformity with the Product Specification for bathymetric Inland ENC. Those updates shall be applied to the Inland SENC automatically. The implementation procedure of the update shall not interfere with the display in use;

- (b) Inland ECDIS shall allow for the display of updates, so that the skipper may review their contents and ascertain that they have been included in the Inland SENC;
- (c) Inland ECDIS shall be capable of revoking automatically applied updates of the Inland ENC data;
- (d) Original Inland ENC editions and later updates shall never be merged;
- (e) The Inland ENC and all updates to it shall be displayed without any degradation of their information content;
- (f) The Inland ENC data and updates to it shall be clearly distinguishable from other information;
- (g) Inland ECDIS shall ensure that the Inland ENC and all updates to it have been correctly loaded into the Inland SENC;
- (h) Inland ECDIS shall keep a record of updates, including the time of application to the Inland SENC;
- (i) The contents of the Inland SENC to be used shall be adequate and up-to-date for the intended voyage.

4. Presentation of Information

4.1 Display Requirements

- (a) The display method shall ensure that the displayed information is clearly visible to more than one observer in the typical conditions of light experienced in the wheelhouse of a vessel by day and night;
- (b) In navigation mode, the display size of the chart presentation shall be at least 270 mm × 270 mm for equipment designed and admitted for the **navigation mode**;
- (c) In information mode, ergonomic aspects shall determine the size. The information displayed shall be readily visible from the conning position.

The display diagonal shall be equal to or larger than 199 mm (7.85 inches). Under all conditions, the boatmaster must be capable of perceiving the displayed information sufficiently in accordance with the Human Machine Interface guidelines.

If the software is sold without a display, the manufacturer's documentation shall include the information that it may only be used as Inland ECDIS in information mode if the display fulfils the requirements of this chapter 4.1;

- (d) The following criteria shall be fulfilled in navigation mode as well as in information mode:
 - alphanumeric data and text shall be presented using a clearly legible non-italic, sans-serif font
 - the font size shall be appropriate for the viewing distance from user positions (i.e. with respect to reading distance and viewing angles) likely to be experienced in the wheelhouse of a vessel
 - the character height and the size of AIS symbols in millimetres shall not be less than 3.5 times the nominal viewing distance in metres
 - the minimum size of AIS symbols and the minimum character height of AIS information shall be 3.5 mm
 - the manufacturer's documentation shall identify the nominal viewing distance for the display equipment;
- (e) The display requirements shall be complied with, whether in landscape or in portrait format;

(f) In information mode, for the size of the display it is recommended to use the size as specified for navigation mode. In the event that space for the installation of the display is a problem, the display size might be reduced taking into account the nominal viewing distance for the display.

4.2 Display Ranges (Scales)

(a) In **information mode** (refer to chapter 5.1 of this section), all scales and ranges are permitted;

(b) In **navigation mode** (refer to chapter 5.2 of this section), only the successive switchable ranges (scales) specified in section 4, chapter 4.7 of this annex are permitted.

4.3 Image Positioning and Orientation

(a) In **information mode**, all kinds of chart orientation are permitted (see chapter 5.1 of this section);

(b) In **navigation mode**, the chart shall be automatically positioned and oriented in the relative motion, head-up orientation with the own vessel's position in the screen centre or off-centred (see chapter 5.2 of this section).

4.4 Display of Inland SENC Information

(a) The display of Inland SENC information shall be divided into the following three display categories:

- Display Base
- Standard Display (Standard Information Density)
- All Display.

The allocation of the feature classes to the display categories is given in detail in the Look-up Tables of appendix 2 to this annex;

(b) The Display Base category shall contain at least the following features:

- bank of waterway (at mean water level)
- shoreline construction (e.g. groyne, longitudinal control dam, training wall — any facility that is considered a hazard to navigation)
- contours of locks and dams
- boundaries of the fairway/navigation channel (if defined)
- isolated dangers in the fairway/navigation channel under water
- isolated dangers in the fairway/navigation channel above water level, such as bridges, overhead wires, etc.
- official aids to navigation (e.g. buoys, lights and beacons);

(c) The Standard Display category shall contain at least the following features:

- the objects of Display Base category
- prohibited and restricted areas
- piers for commercial vessels (cargo and passenger)
- kilometre and hectometre or mile marks on the banks;

(d) The All Display category shall display all features that are contained in the Inland SENC, individually on demand;

(e) When starting the Inland ECDIS, it shall come up with the Standard Information Density as defined in S-52 and the Glossary of Terms in section 5 of this annex;

- (f) Inland ECDIS shall be switchable to the Standard Information Density at any time by a single operator action;
- (g) Inland ECDIS shall clearly indicate the information density in use at all times;
- (h) Time variable depth information in the Inland ENC shall be displayed independently of the three display categories referred to in subparagraph (a).

4.5 Display of Radar Information

- (a) In **navigation mode**, the radar image shall have the highest display priority and shall only be permitted to be presented in the relative motion, head-up mode. If the system is also type approved for maritime ECDIS, true motion and north-up mode may be implemented, but only for working in **information mode**;
- (b) The overlaid Inland SENC shall match in position, range and orientation. The radar image and the position from the position sensor shall both be adjustable for the antenna offset to the conning position;
- (c) The overlaid radar image shall conform to the minimum requirements as specified in chapter 4.14 of section 4 of this annex;
- (d) The overlaid radar image may contain additional navigational information. Any additional navigational information and tracking and tracing symbols shall, however, in no way degrade the display of the original radar content.

4.6 Display of Other Navigational Information

- (a) Inland ECDIS and additional navigational information (Inland AIS) shall use a common conventional geodetic coordinate reference system;
- (b) It shall be possible to display the skipper's own vessel's position on the screen;
- (c) It shall be possible for the skipper to select safety depth limits;
- (d) Inland ECDIS shall indicate the falling short of the safety depth limits.

4.7 Colours and Symbols

- (a) The display of colours and symbols to represent SENC information shall at least be able to comply with the regulations of section 3 of this annex. Additionally, other user-selectable symbol sets are permitted;
- (b) To present navigational elements and parameters as listed in IMO Resolution MSC.232(82), Appendix 3, other colours and symbols than those mentioned in subparagraph (a), chapter 4.7 of this section shall be used;

4.8 Data and Display Accuracy

- (a) The accuracy of the calculated data that are presented shall be independent of the display characteristics and shall be consistent with the Inland SENC accuracy;
- (b) The Inland ECDIS in **navigation mode** shall provide an indication whether the display uses a smaller display range than the accuracy of the Inland ENC data offers (over-scale indication);
- (c) The accuracy of all calculations performed by Inland ECDIS shall be independent of the characteristics of the output device and shall be consistent with the Inland SENC accuracy;
- (d) Bearings and distances drawn on the display or those measured between features already drawn on the display, shall have accuracy no less than that afforded by the resolution of the display.

5. Operation

5.1 Information Mode

- (a) **Information mode** shall be used for information only and not for navigation;
- (b) In **information mode**, all kinds of chart orientation, rotation, zooming and panning are allowed. However, it is recommended to use the same fixed ranges as in **navigation mode** and the chart orientation whether:
- to north, or
 - to the fairway axis at the actual position, or
 - to the actual vessels heading;
- (c) It shall be possible to scroll the chart manually on the screen with the fairway axis in line with the vertical screen axis;
- (d) Inland ECDIS may be connected to a positioning sensor to scroll the chart picture automatically and to display the section of the chart matching the actual surrounding, namely in the operator-selected range;
- (e) Information regarding the position and orientation of other vessels, gathered by communication links like AIS, shall be only displayed if they are up-to-date (nearly real-time) and accurate. If the heading of other vessels is not available, the position and the orientation of other vessels shall not be presented by:
- a directed triangle, or
 - a true outline (to scale).

In this case, the usage of a generic symbol is recommended.

The following time out values are recommended (from IEC 62388):











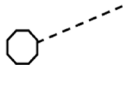
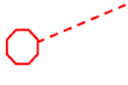
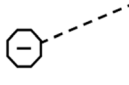
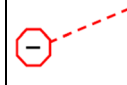
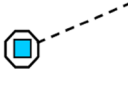

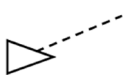
<i>Category of vessel</i>	<i>Nominal reporting interval</i>	<i>Maximum time out value</i>	<i>Nominal reporting interval</i>	<i>Maximum time out value</i>
	<i>class A</i>	<i>class A</i>	<i>class B</i>	<i>class B</i>
Vessel at anchor or moored and not moving faster than 3 knots (class B not moving faster than 2 knots)	3 min	18 min	3 min	18 min
Vessel at anchor or moored and moving at more than 3 knots	10 s	60 s	3 min	18 min
Vessel operating in SOLAS mode, moving at 0 to 14 knots	10 s	60 s	30 s	180 s
Vessel operating in SOLAS mode, moving at 0 to 14 knots and changing course	3 1/3 s	60 s	30 s	180 s
Vessel operating in SOLAS mode, moving at 14 to 23 knots	6 s	36 s	30 s	180 s
Vessel operating in SOLAS mode, moving at 14 to 23 knots and changing course	2 s	36 s	30 s	180 s
Vessel operating in SOLAS mode, moving faster than 23 knots	2 s	30 s	30 s	180 s

<i>Category of vessel</i>	<i>Nominal reporting interval</i>	<i>Maximum time out value</i>	<i>Nominal reporting interval</i>	<i>Maximum time out value</i>
	<i>class A</i>	<i>class A</i>	<i>class B</i>	<i>class B</i>
Vessel operating in SOLAS mode, moving faster than 23 knots and changing course	2 s	30 s	30 s	180 s
Vessel operating in inland waterway mode	2–10 s	60 s	–	–

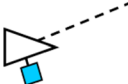
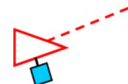
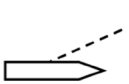
The AIS targets should be marked as outdated if the position information of moving vessels is older than 30 seconds.

Information on the intention (blue sign) or the number of blue cones of other vessels, the status of signals, weather warnings (from Meteoalarm: www.meteoalarm.eu) and the water level received via Inland AIS may be displayed. The information on the intention (blue sign) shall only be displayed on the right side of the symbol, if the heading of the vessel is available. If no heading information is available, the information shall only be displayed in a direction independent form.

The following table is providing an example for the display:

<i>Visualization of Blue Sign status 0 to 2 and dangerous goods</i>							
<i>Blue Sign</i>		<i>Not connected or not available</i>		<i>Not set</i>		<i>Set</i>	
<i>Blue cones</i>		<i>No</i>	<i>1 to 3</i>	<i>No</i>	<i>1 to 3</i>	<i>No</i>	<i>1 to 3</i>
<i>Heading</i>	<i>No</i>						
	<i>Symbol</i>						
	<i>True shape</i>						

(f) Information regarding AIS base stations, AIS Aids to Navigation (AtoN) and AIS Search and Rescue Transmitters (SART) may be displayed, if the symbols can be distinguished from other symbols (e.g. symbols 2.10 and 2.11 of IEC 62288 Edition 2, Table A.2);

(g) Information received by an AIS device and required by local police regulations shall be displayed;

(h) It shall be possible to display all information transmitted by an AIS on user request.

5.2 Navigation Mode

(a) In **navigation mode**, the Inland ECDIS display shall be integrated with the own vessel's radar information. The radar information shall be clearly distinguishable from the SENC information;

(b) The Integrated Display shall be in accordance with the requirements for radar on inland waterways as specified in chapter 4.14 of section 4 of this annex;

(c) The chart and the radar image shall match in size, position and orientation within the limits as specified in chapters 3.4 and 8.3.2 of section 4 of this annex;

(d) The Integrated Display shall only be presented in the head-up orientation. Other orientations are permitted in systems with an additional maritime ECDIS type approval. If such a system is used in true motion and/or north-up mode on European inland waterways, it is considered to be working in **information mode**;

(e) It shall be possible for the operator to adjust the off-set values between the positions of the position sensor and the radar antenna of the vessel so that the SENC display matches the radar image;

(f) It shall be possible to temporarily remove either the ECDIS or the radar information by a single operator action;

(g) The vessel's position shall be derived from a continuous positioning system of which the accuracy is consistent with the requirements of safe navigation;

(h) **Navigation mode** shall provide an indication when the input from the position-fixing system is lost;

Navigation mode shall also repeat, but only as an indication, any alarm or indication passed to it from a position fixing system;

(i) The positioning system and the SENC shall be based on the same geodetic datum;

(j) In **navigation mode**, the data referred to chapter 3.1, subparagraph (c), first to seventh indent, of this section, and the following elements shall always be visible and shall not be obscured by other objects:

- Headline line (as required by ETSI EN 302 194-1:2006)
- Bearing line (as required by ETSI EN 302 194-1:2006)
- Range rings (as required by ETSI EN 302 194-1:2006)
- Navigation lines (as required by ETSI EN 302 194-1:2006)
- P-Lines
- Buoys
- Inland AIS symbols
- Inland AIS labels (if displayed)
- AtoN information.

The transparency of the radar overlay shall, therefore, be user defined. It shall be possible to switch Inland AIS labels off, either manually or on base of a configured timeout value;

(k) Information regarding the position and orientation of other vessels, gathered by other communication links than the own radar, may be displayed only if they are up-to-date (nearly real-time) and meet the accuracy that is required for the support of tactical and operational navigation. Position information of the own vessel that is received from a repeater station shall not be displayed;

(l) As tracking and tracing information (for example, AIS) of other vessels is useful for the planning of the passing, but of no use during passing itself, tracking and tracing (AIS) symbols shall not disturb the radar image during passing and shall be faded out therefore. Preferably the application shall allow the skipper to define the area where the symbol is faded out;

(m) If the heading of other vessels is available, the position and the orientation of other vessels may be presented by:

- a directed triangle, or
- a true outline (to scale).

In all other cases, a generic symbol shall be used (an octagon is recommended, a circle shall not be used for applications which are certified according to maritime standards);

(n) Information that another vessel is carrying blue cones or lights may be displayed by a different colour of the vessel symbol. The number of the blue cones/lights shall only be displayed in the pick report;

(o) Information on the intention of another vessel to pass on starboard (blue sign) may only be displayed on the right side of the directed triangle symbol or of the scaled shape if the heading of this vessel is available. If no heading information is available, the information shall only be displayed in a direction independent form;

(p) Information regarding the position of AIS base stations, AIS AtoN and AIS SART may be displayed, if the symbols can be distinguished from other symbols (e.g. symbols 2.10 and 2.11 of IEC 62288 Edition 2, Table A.1).

5.3 Operation and Control Elements

(a) Inland ECDIS shall be designed following having regard to ergonomic principles for user-friendly operation;

(b) The Inland ECDIS equipment shall have a minimum of operation and control elements (see section 4 of this annex);

(c) Operation and control elements, and indicators for connected sensors, may be integrated in Inland ECDIS;

(d) Standard settings and user-defined settings shall be easily retrievable.

6. Connections with other Equipment

(a) Inland ECDIS shall not affect the performance of any connected equipment adversely. Similarly, the connection of optional equipment shall not degrade the performance of Inland ECDIS;

(b) Inland ECDIS shall be capable of generating information to other systems, e.g. for the purpose of electronic reporting;

(c) The relevant requirements of controls and indicators to connected equipment shall be fulfilled.

7. Indications and Alarms

7.1 Built-in Test Equipment (BITE)

Inland ECDIS in navigation mode shall be provided with the means for carrying out on-board tests of major functions either automatically or manually. In case of a failure, the module at fault shall be shown.

7.2 Malfunctions

(a) Inland ECDIS in **navigation mode** shall provide a suitable alarm or indication of system malfunctions; (refer to chapter 9 of section 4 of this annex);

(b) Inland ECDIS in **information mode** shall provide a suitable alarm or indication of missing input from — if connected — GNSS receiver, AIS and heading device;

(c) Inland ECDIS shall provide appropriate alarms or indications of malfunction of the equipment with respect to the displayed information.

8. Fall-back Arrangements

8.1 Insufficient Accuracy of the SENC Positioning

In **navigation mode**, the SENC shall be automatically switched off, if the SENC positioning does not match the radar picture within the limits of chapters 5.1 and 5.2 of section 4 of this annex.³

8.2 Defects

(a) If the Inland ECDIS system in navigation mode has an evident defect, it shall provide a suitable alarm (refer to chapters 4.16 and 9 of section 4 of this annex);

(b) Facilities enabling a safe take-over of the functions of Inland ECDIS in navigation mode shall be provided in order to ensure that an Inland ECDIS failure does not result in a critical situation.

9. Power Supply in Navigation Mode

The Inland ECDIS shall have its own separate fused power supply.

³ On wide inland waterways, Basin Administration may prescribe that Inland ECDIS shall provide a suitable alarm and/or indication, if the SENC positioning does not match the radar picture within the limits of section 4, chapters 5.1 and 5.2.

Section 2: Data Standard for Inland ENC

1. Introduction

(a) The Data Standard for Inland ENC describes the technical specifications to be used:

- for the exchange of digital hydrographic data between national inland waterway authorities, and
- for its distribution to manufacturers, skippers and other users;

(b) This Data Standard shall be used for the production of Inland ENC and bathymetric Inland ENC. The transfer and distribution of Inland ENC and bathymetric Inland ENC shall take place in such a way that data integrity is ensured;

(c) This Data Standard is based on S-57 (see the table “Comparison of the structures of the standard for (Maritime) ECDIS and of the technical specifications for Inland ECDIS” in appendix 4 to this annex);

(d) This Data Standard describes the necessary additions and clarifications to S-57 and the application of S-57 for the purpose of use in Inland ECDIS applications;

(e) This Data Standard shall be compliant to Appendix 1, Product Specification for Inland ENC, and Appendix 3, Product Specification for bathymetric Inland ENC, to this annex.

2. Theoretical Data Model

The description of the theoretical data model in Part 2 of S-57 shall apply to the theoretical data model of Inland ENC and bathymetric Inland ENC.

3. Data Structure

The description of the data structure in Part 3 of S-57 shall apply to the data structure of Inland ENC and bathymetric Inland ENC.

4. Product Specification for Inland ENC and bathymetric Inland ENC

(a) The Product Specifications for Inland ENC and for bathymetric Inland ENC (see appendices 1.0 and 3.0 to this annex) are sets of specifications intended to enable chart producers to produce a consistent Inland ENC or bathymetric Inland ENC, and manufacturers to use that data efficiently in an Inland ECDIS that satisfies the Performance Standard for Inland ECDIS set out in section 1;

(b) Data for Inland ENC shall be made available to all manufacturers of applications. An Inland ENC shall be produced in accordance with the rules laid down in appendix 1 to this annex and shall be encoded using the following documents referred to therein:

- the Inland ENC Feature Catalogue (see appendix 1.1), and
- the rules described in the Inland ENC Encoding Guide (see appendix 1.2).

A bathymetric Inland ENC shall be produced in accordance with the rules laid down in appendix 3 to this annex and shall be encoded using:

- the bathymetric Inland ENC Feature Catalogue (see appendix 3.1), and
- the rules described in the Inland ENC Encoding Guide (see appendix 1.2);

(c) Inland ENC and bathymetric Inland ENC approved for navigation mode shall be produced in accordance with the Data Standard and the Product Specification referred to in this section.

Section 2A: Codes for Producers and Waterways (in addition to IHO-S-62 ENC Producer Codes)

(a) Codes for producers of Inland ENCs as well as the registration procedure are those mentioned in S-62;

(b) Administrations or private companies which produce Inland ENCs and which are not mentioned in S-62 and administrations or private companies which decide to produce Inland ENCs, shall register a producer code at the S-100 registry of IHO at <http://registry.iho.int>;

(c) Since a producer code alone is not sufficient to establish whether an Inland ENC is appropriate to be used in navigation mode, the competent authorities designated by member States for the RIS application and for the international exchange of data or referred to in Article 8 of Directive 2005/44/EC, shall maintain and provide via their official website an up-to-date list of Inland ENCs approved for navigation mode within their geographical area of responsibility. The list shall include the file name of the ENC cell, the stretch of the inland waterway that is covered, the edition number, the issue date and a list of available update files to the currently valid edition also with their issue dates. The list shall include all Inland ENC for which the cell complies with the requirements as regards the minimum content and is approved for navigation mode.

The notification of the competent authorities shall include information on the geographical area of responsibility and the official website of the competent authorities;

(d) The following codes for waterways shall be used in the file name of Inland ENCs:

<i>Waterway Code</i>	<i>Waterway Name</i>	<i>Remark</i>
AC	Albertkanaal/Canal Albert	
AKL	Afleidingskanaal van de Leie	
BA	Balaton	
BCR	Branche de la Croyère	
BED	Benedendijle	
BEN	Beneden-Nete	
BEZ	Beneden-Zeeschelde	
BH	Kanaal Bocholt – Herentals	
BK	Boudewijn Kanaal	
BLO	Branche de La Louvière	
BME	Basse-Meuse	
BN	Kanaal Briegden – Neerharen	
BOS	Bovenschede	
BOZ	Boven-Zeeschede	
BRW	Beetzsee-Riewendsee-Wasserstraße	
BSK	Berlin-Spandauer Schifffahrtskanal	including Westhafenkanal and Charlottenburger Verbindungskanal
BZ	Beneden Zeeschede	
CCB	Canal Charleroi-Bruxelles	
CCG	Canal du Centre à Grand Gabarit	
CHV	Canal de Haccourt à Visé	
CLA	Canal de Lanaye	

<i>Waterway Code</i>	<i>Waterway Name</i>	<i>Remark</i>
CMO	Canal de Monsin	
CPC	Canal Pommeroeul-Condeé	
D	Danube	including Sulina branch
DA	Danube Chilia branch	
DAW	Dahme-Wasserstraße	
DB	Dunarea Barcea	
DCC	Danube Cernovoda canal	
DDT	Dijledoortocht	
DE	Dortmund-Ems Kanal	
DEN	Dender	
DHK	Datteln-Hamm Kanal	
DKW	Kanaal Dessel – Kwaadmechelen	
DR	Drava	
DTS	Kanaal Dessel – Turnhout – Schoten	
DUK	Ràckevei-Duna	
DUM	Mosoni-Duna	
DUR	Gekanaliseerde Durme (Beneden-Durme)	
DUS	Szentendrei-Duna	
DV	Dunarea Veche	
EL	Elbe	
ELK	Elbe-Lübeck-Kanal	
EH	Elbe-Havel-Kanal	
EMS	Ems	
EPP	Embranchement Principal	
ES	Elbe-Seiten-Kanal	
EV	Estuaire Vaart	Estuary shipping between Zeebrugge and the Dutch border
GA	St. Gheorghe-Arm	
GMO	Grand Large de Mons	
GPE	Grand Large de Péronnes	
HES	Haut-Escaut	
HO	Havel-Oder-Wasserstraße	
HVK	Havelkanal	
IJZ	IJzer	
KB	Kanaal naar Beverlo	
KBK	Kanaal Bossuit – Kortrijk	
KGO	Kanaal Gent-Oostende	
KGT	Kanaal Gent-Terneuzen	
KK	Küstenkanal	
KLD	Kanaal Leuven – Dijle	
KND	Kanaal Nieuwpoort – Duinkerken	
KPN	Kanaal Plassendale – Nieuwpoort	
KRL	Kanaal Roeselare – Leie	

<i>Waterway Code</i>	<i>Waterway Name</i>	<i>Remark</i>
KTR	Kanaltrave	
KVE	Kanaal van Eeklo	
LA	Lahn	
LOK	Lokanaal	
LR	Leie/Lys River	
MA	Main	
MD	Main-Donau-Kanal	
ME	Müritz-Elde-Wasserstraße	
MEU	Meuse	
ML	Mittelland-Kanal	
MMI	Meuse Mitoyenne Sud	
MO	Mosel	
MOE	Moervaart	
N	Dnipro	
NBP	Canal Nimy-Blaton – Peronnes	
ND	Desna	
NE	Neckar	
NOK	Nord-Ostsee-Kanal	
NPR	Prypiat	
NSU	Sula	
NTK	Netekanaal	
NVO	Vorskla	
OD	Oder	
OL	Olt	
PE	Peene	
PHV	Potsdamer Havel	
PK	Plassendale Kanaal	
RH	Rhine	
RHK	Rhein-Herne-Kanal	
RL	Nederrijn/Lek	
ROG	Ringvaart om Gent	
RU	Ruhr	
RUP	Rupel	
SA	Sava	
SAM	Sambre	
SE	Schelde	
SI	Siò-czatorna	
SKH	Stichkanal Mittelland-Kanal – Hildesheim	
SKL	Stichkanal Mittelland-Kanal – Hannover- Linden	
SKO	Stichkanal Mittelland-Kanal – Osnabrück	
SKS	Stichkanal Mittelland-Kanal – Salzgitter	

<i>Waterway Code</i>	<i>Waterway Name</i>	<i>Remark</i>
SL	Saale	
SM	Smeermaas	
SO	Spree-Oder-Wasserstraße	
SPI	Spierekanaal	
SR	Saar	
SRV	Schelde-Rijnverbinding	
TEK	Teltowkanal	
TI	Tisza	
TLE	Toeristische Leie (Leie)	
UH	Untere Havel-Wasserstraße	
UWE	Unterweser	from km UWE 0.00
VKN	Verbindingskanaal Nieuwpoort	
WA	Waal	
WDK	Wesel-Datteln-Kanal	
WE	Mittelweser	until km 366.65/UWE 0.00
WOD	Westoder	
ZBS	Zeekanaal Brussel-Schelde	
ZUL	Vertakking van Zulte	
ZWV	Zuid-Willemsvaart	

Section 3: Presentation Standard for Inland ECDIS

1. Introduction

(a) This Presentation Standard for Inland ECDIS describes the technical specifications to be used for the presentation of Inland ECDIS data. The presentation shall take place in such a way that none of the information is lost;

(b) This Presentation Standard is based on S-52 (see the table “Comparison of the structures of the standard for (Maritime) ECDIS and of the technical specifications for Inland ECDIS” in appendix 4 to this annex);

(c) This Presentation Standard describes the necessary additions and clarifications to S-52 and the application of S-52 for the purpose of use in Inland ECDIS applications;

(d) The presentation of Inland ECDIS data shall meet the requirements of the Presentation Standard described in section 3 and appendix 2, Status of the Presentation Library for Inland ECDIS, to this annex;

(e) Definitions of terms may be found in:

- Part 1, clause 5 of S-57
- IHO Special Publication S-32, Appendix 1
- the Glossary for Inland ECDIS in section 5 of this annex.

2. Presentation Library for Inland ECDIS

S-57 data sets describe the data standard for Inland ENC, however, they do not contain any information about how the data is going to be presented. The chart presentation is generated online in the Inland ECDIS application. For that purpose, the Inland ECDIS application uses machine-readable symbolization instructions for each feature, which is drawn on the screen. For the presentation of ENC, the S-52 standard is mandatory. The S-52 standard contains all rules which are necessary for the symbolization and presentation of ENC on the screen.

Since the features, attributes and attribute values for ENC were extended for Inland ENC and bathymetric Inland ENC, an extension of the S-52 standard is necessary in order to be able to also display the features specific to inland navigation. All extensions apply to Edition 3.4 of the IHO ECDIS Presentation Library (Annex A to former S-52).

2.1 Components of S-52 and Inland ECDIS Presentation Library

2.1.1 The major components of the S-52 Presentation Library are:

- a library of symbols, line styles and fill styles
- a colour coding scheme which includes the IHO colour tables for day, dusk and night time
- a set of symbology command words from which machine readable instructions can be assembled. The result is a symbology instruction, which is processed to symbolize ENC features in turn
- a set of conditional symbology procedures to decide the appropriate symbolization in cases determined by the skipper's selection (e.g. safety contour) or for complex symbols (e. g. top marks on buoys and beacons)
- a set of look-up tables that link feature descriptions from the SENC database to the appropriate symbology instructions depending on whether:
 - the link is straight forward, i.e. a direct relationship between a feature's description and its presentation such as a buoy or a land area. In this case, the look-up table provides the symbology instruction to show a symbol, an area fill, or a line style;

- the link is conditional, i.e. depending on circumstances, for example a depth area, whose colour fill depends on the choice of the safety contour. In this case, the look-up table refers the decision to a conditional symbology procedure that selects the appropriate symbology instructions later.

2.1.2 Inland ECDIS shall use all S-52 components plus extensions in:

- Look-up tables
- Symbol library
- Conditional symbology procedures.

The extensions are described in appendix 2, “Status of the Presentation Library for Inland ECDIS”, to this annex.

2.2 Look-up Tables

2.2.1 For each geometry type (point, line, area) there is a separate look-up table. Each entry in a look-up table consists of the following fields:

- 6-character code of the feature class (acronym);
- Attribute combination;
- Symbolization instructions;
- Display priority, 0–9 (comparable with drawing layers);
- Radar code;
- Display category (Display base, standard, all other);
- “Viewing group”, more refined grouping of features than the display categories.

Figure 1

Example Entry of a Look-up Table

“LNDMRK”, “CATLMK17”, “SY(TOWERS01)”, “7”, “O”, “OTHER”, “32250”
--

In this case, the feature LNDMRK is shown by the symbol TOWERS01 with priority 7, if the attribute CATLMK equals 17. The feature lies over the radar.

The presentation of features in a specific area that are contained in different cells of the same usage follows the entries in the look-up tables.

2.2.2 The Presentation Library provides five look-up tables:

- paper chart point symbols
- simplified point symbols
- line symbols
- plain area boundary symbols
- symbolized area boundary symbols.

2.3 Conditional Symbology Procedures (CS)

CS procedures shall be generated for features of which the symbolization:

- depends on application settings, e.g. safety contour
- depends on other features, e.g. top marks and their structure
- is too complex to be defined in a direct look-up table entry.

CS Procedures, which shall be modified or implemented in an Inland ECDIS additionally to the CS Procedures of S-52, are described in appendix 2, “Status of the Presentation Library for Inland ECDIS”, to this annex.

2.4 Colours

Colours used in an ECDIS are defined in an absolute manner, independently from the monitor used (using CIE coordinates). This ensures that ECDIS charts look similar on monitors of different suppliers. CIE values are converted into RGB values by means of a colour calibration software which must be used by the manufacturer.

Commercial displays usual in the trade are seen as matching these requirements.

Due to the fact that various lighting conditions might occur on the bridge of a vessel, it is necessary to offer presentations with different brightness levels. For each level a separate colour table exists.

The represented colour scheme shall be chosen on the basis of ergonomic and physiological factors and the representation of indications in different colours shall not result in mixed colours by superimposing.

2.5 Presentation of notice marks

Notice marks which are located at the river bank are presented in the chart displayed by generic symbols (notmrk01, notmrk02 and notmrk03). This does not apply to the notice marks on bridges.

Additionally, applications are required to be able to display the detailed symbol, which is similar to the real-world indication, and the full set of object information of a user-selected notice mark.

Notice marks that are located at bridges, shall be symbolized according to the orientation of the bridge.

Notice marks which specify distances or a velocity, shall not be symbolized with the number itself, but only with that symbol which gives the general regulation or information.

Section 4: Operational and Performance Requirements, Methods of Testing and Required Test Results

1. Introduction

This section specifies the minimum requirements contained in section 1 of this annex and describes the test procedures and the required results concerning the hardware, the software, the functions, the operation, the display and the interfaces to other equipment on board of vessels.

2. Operating Modes and System Configuration

2.1 Operating Modes

(a) The Inland ECDIS technical specifications distinguish two operating modes: **navigation mode** and **information mode**;

(b) Inland ECDIS equipment designed for operating in **navigation mode** shall fulfil the requirements of this annex and the standards on navigational radar equipment and rate-of-turn indicators. For Inland ECDIS in navigation mode, a type approval is required by the competent authorities referred to in the annex to resolution No. 61 or Annex II of Directive 2016/1629;

(c) For Inland ECDIS equipment designed for **information mode** only, the requirements of this section 4 are to be understood as technical (operational and performance) requirements. The producer has to document the conformity with these technical requirements. A type approval is not required for Inland ECDIS in information mode. The documentation shall be made available to the competent authorities and users on request.

2.2 System Configurations

2.2.1 *System configuration 1: Inland ECDIS equipment, stand-alone-system without connection to radar*

In this system configuration, only operation in **information mode** is possible (see section 4B, figure 1).

2.2.2 *System configuration 2: Inland ECDIS equipment, parallel installation and connection to radar*

This system configuration allows operation in **information mode** as well as in **navigation mode** (see section 4B, figure 2).

2.2.3 *System configuration 3: Inland ECDIS equipment, monitor shared with connected radar equipment*

In this system configuration, the monitor of the radar equipment is shared with the Inland ECDIS equipment. Prerequisite for this mode are matching graphic parameters for both video signals and a video switch, which allows a fast switchover of the video sources (see section 4B, figure 3).

This system configuration allows operation in **information mode** as well as in **navigation mode**.

2.2.4 *System configuration 4: Radar equipment with integrated Inland ECDIS functionality*

This system configuration is a radar installation with integrated Inland ECDIS functionality that can be operated in **information mode** as well as in **navigation mode** (see section 4B, figure 4).

3. Performance Requirements

3.1 Hardware Performance

(a) Inland ECDIS in navigation mode equipment shall be designed and manufactured to withstand typical environmental conditions prevailing on board of a vessel without any degradation in quality and reliability. Furthermore, it shall not disturb other communication and navigation equipment;

(b) In the configuration as described in paragraph 2.2.4 of this section, all components of Inland ECDIS equipment installed inside the wheelhouse shall fulfil the requirements of the class B “protected from weather” equipment as specified in the standard IEC 60945 with the exception that the test temperature range is limited to 0° C to + 40° C (whereas the test temperature range in IEC 60945 is specified from – 15° C to + 55° C) unless specified differently in this annex. For the configurations described in paragraphs 2.2.2 and 2.2.3 of this section, CE conformity is sufficient.

3.2 Software Performance

Software for the operation, visualization and functionality of Inland ECDIS equipment shall be designed, developed, implemented, and tested in accordance with the software requirements described in section 4A of this annex.

3.3 Performance of Operation Controls

(a) The operation of the system shall be simple, appropriate and conform to common human interface standards. The operational state of the system and the connected technical sub devices has to be clearly indicated;

(b) The number of operational controls shall be as low as possible and restricted to the required number;

(c) Wireless remote controls are not permitted;

(d) The ON/OFF switch shall perform and shall be arranged in such a way that inadvertent operation is not possible;

(e) The symbols of the operating controls shall have a minimum character height of 4 mm and shall be readable under all conditions that may exist in a wheelhouse;

(f) The brilliance and the illumination of the operating controls shall be adjustable to the required value.

3.4 Display Performance

The provisions of chapters 3.4.2 to 3.4.7 are recommended for Inland ECDIS in information mode.

3.4.1 *Display dimensions*

(a) In **navigation mode**, the minimum chart and radar display area shall be at least 270 mm × 270 mm;

(b) In information mode, the requirements of subparagraph (c) of chapter 4.1, section 1 shall be applicable.

3.4.2 *Display orientation*

(a) A rectangular display may be mounted in landscape or in portrait orientation under the prerequisite that the minimum dimensions set out in paragraph 3.4.1 are fulfilled;

(b) Because of the limited space available in the typical wheelhouse of an inland vessel and the fact that a vessel usually follows the fairway axis, the display shall be installed preferably in the portrait orientation.

3.4.3 *Display resolution*

A display resolution of 5 m in the 1200 m range is required. This leads to a maximum pixel dimension of 2.5 m × 2.5 m, i.e. about 1000 pixels at the short edge of the display.

3.4.4 *Display colours*

The system shall be able to display ergonomically proven colour combinations for day and night.

3.4.5 *Display brilliance*

The brilliance of the display shall be adjustable to every operational required value. This is especially valid for the lowest value during operation at night.

3.4.6 *Picture renewal*

- (a) The picture renewal rate shall not be shorter than that of the radar picture (≥ 24 pictures per minute);
- (b) Between two consecutive renewals no fluctuations of brilliance shall occur;
- (c) On raster scan displays, the frame repetition rate shall not be lower than 60 Hz.

3.4.7 *Display technology*

Display systems that are insensitive to the magnetic fields that may occur in the wheelhouse of an inland vessel shall be used.

4. **Operational Functions**

4.1 **Operating Mode**

- (a) If the equipment is able to work in both operation modes, it shall provide for the possibility of switching between **navigation mode** and **information mode**;
- (b) The operation mode in use shall be displayed;
- (c) Suitable measures are required to prevent the inadvertent switching-off of the **navigation mode**.

4.2 **Equipment Pre-sets (Store/Recall) in Navigation Mode**

- (a) After starting, the Inland ECDIS equipment shall come up with a moderate brilliance pre-set which neither blinds in a dark environment nor makes the picture invisible in a bright environment;
- (b) Other parameters may come up with their values at the time before switching off or from stored settings.

4.3 **Presentation of SENC Information in Navigation Mode**

- (a) The radar picture shall be clearly distinguishable from the chart independent of the chosen colour table;
- (b) Only a monochrome presentation of the actual radar picture is permitted;
- (c) The presentation of chart information shall not mask or degrade important parts of the radar picture. This shall be ensured by appropriate entries into the look-up tables (refer to section 3 of this annex, chapter 2.2, field "Radar code"). The transparency of the radar overlay shall therefore be user-defined;
- (d) Chart and radar picture presentation shall have the same scale;
- (e) The heading line shall be always visible;

(f) Additionally, the skipper's own vessel's contour and the safety contours may be inserted.

4.4 Chart Orientation, Positioning and Shifting

(a) In **navigation mode**, only the chart orientation "relative motion, head up" and the "centred" or "off-centred" presentations, as required for the radar picture, are permitted;

(b) In **information mode**, at least the chart orientations "north" and "parallel to the waterway axis" as well as positioning are recommended. By connection of a positioning sensor, the displayed part of the chart can automatically follow the skipper's own vessel's position.

4.5 Position and Bearing of the own vessel

(a) In **navigation mode**, the own vessel's position shall always be visible in the display area, whether "centred" or "off-centred";

(b) In **navigation mode**, the heading line which runs from the display centre to the top and which shall be always visible, shall represent the heading of the skipper's own vessel.

4.6 Information Density

The information density shall be at least adjustable to the three switch steps: "Base", "Standard" and "All Information". The latter displays all other features in addition to the "Standard" display, individually on demand. All corresponding visible features are defined in the Performance Standard and the Presentation Standard (including the Presentation Library for Inland ECDIS) (see sections 1 and 3 of this annex).

4.7 Ranges/Range rings

(a) In **navigation mode**, the following fixed ranges and range rings are prescribed according to the radar regulations:

<i>Range</i>	<i>Range rings</i>
500 m	100 m
800 m	200 m
1 200 m	200 m
1 600 m	400 m
2 000 m	400 m
4 000 m	800 m

(b) Smaller and larger ranges with a minimum of four and a maximum of six range rings are permitted;

(c) Inland ECDIS equipment in **navigation mode** shall have fixed range rings with the intervals set out in subparagraphs (a) and (b) and at least one variable range marker (VRM);

(d) Switching on/off of fixed and variable range markers shall be independent of each other and their display shall be clearly distinguishable;

(e) The position of VRM and the corresponding displayed distance shall use the same increments and resolution;

(f) The functions of VRM and the electronic bearing line (EBL) may additionally be realized by a cursor and by a corresponding numerical display, showing the range and bearing of the cursor position.

4.8 Picture Brilliance in Navigation Mode

- (a) The brightness of the display shall be adjustable to the operationally necessary value. This applies in particular to operation in darkness;
- (b) Chart and radar picture shall have separate brightness controls;
- (c) Because of the strongly different environment brightness of bright day and dark night, another control for the basic brightness of the display shall be available additionally to the colour tables in the menu.

4.9 Picture Colours

At least the colour combinations included in the S-52 Presentation Library, 6.0 (colour tables) for day, dusk and night shall be supported.

4.10 Pick report

- (a) It shall be possible to get all underlying textual and/or graphical information concerning user selections of the features that are displayed in the chart;
- (b) This additional textual and/or graphical information shall not hamper the view of the waterway in the navigational chart.

4.11 Measurement Features

- (a) Measurement features for distances and bearings are required;
- (b) Resolution and accuracy shall at least be the same as those of the display, but may not suggest better values than those of the chart data.

4.12 Input and Editing of Skippers' Own Chart Entries

- (a) Inland ECDIS equipment shall allow input, storing, modifying and deletion of additional chart information by the skipper (skippers' own features) in navigation mode as well as in information mode;
- (b) These own chart entries shall be distinguishable from the SENC data, and shall not overlay or degrade the radar picture in navigation mode.

4.13 Loading and Updating of SENCs

- (a) All **manual** activities concerning loading or updating of charts shall be possible only outside the **navigation mode**;
- (b) **Automatic** updating shall not downgrade the performance of the navigation display;
- (c) A rollback function shall be implemented to allow restoring to the last working combination.

4.14 Radar Picture Presentation and Overlay

- (a) The radar image representation is mandatory for operation in **navigation mode**;⁴
- (b) The dimensions, resolution and attributes of the radar presentation shall fulfil the relevant radar requirements;
- (c) The radar picture shall not be degraded by other contents of the picture (see also subparagraph (c) of chapter 4.3 of this section);

⁴ On wide inland waterways, Basin Administration may, where appropriate, consider this mandatory requirement as a recommendation.

(d) Provided the functional requirements are fulfilled, overlaying of different information layers is permitted;

(e) The overlay of information regarding the position and orientation of other vessels is only allowed when:

- the information is up-to-date (nearly real-time) and
- the age of information does not exceed the maximum time out values provided in the first table in subparagraph (e) of chapter 5.1 of section 1. The symbols shall be marked as outdated if the age of information exceeds 30 seconds for moving vessels. The position information of the own vessel shall only be displayed when the position is detected by an on-board subsystem and not if the position is received from a repeater station;

(f) The overlaid information derived from tracking and tracing devices regarding the position and orientation of other vessels shall be faded out at a user-definable range. The activation of this feature and the selected range of the restricted area shall be indicated on the display;

(g) Only if the heading of other vessels is available, the position and the orientation of those other vessels may be presented by:

- a directed triangle, or
- a true outline (to scale).

In all other cases, a generic symbol shall be used (an octagon is recommended, a circle shall be used for inland applications only);

(h) It shall be possible to switch off the chart and any other information layer and to display only the radar picture by one easily accessible control element or menu area;

(i) If the quality and plausibility monitoring of the Inland ECDIS equipment detects that the chart cannot be oriented and/or positioned with the accuracy required by this annex, an alarm shall be presented on the display and the chart shall be switched off automatically. If there is no radar signal, the information mode shall be displayed. In both cases, a warning or an alarm shall be given. The switching shall always be possible by manual action.

4.15 Inland ECDIS Functions with Immediate Access

(a) The following operational functions require direct access:

- RANGE
- BRILLIANCE
- COLOURS
- INFORMATION DENSITY;

(b) These functions shall have either own control elements or own menu areas, which are arranged in the highest menu level and are permanently visible.

4.16 Permanently Visible Function Parameters

The following function parameters shall always be visible:

- actual RANGE
- sensor STATUS (in **navigation mode**: radar tuning, position quality, alarms; in **information mode**: if connected, GNSS receiver, AIS and heading)
- selected WATER LEVEL (if available)
- selected SAFETY DEPTH (if available)
- selected INFORMATION DENSITY.

5. Service Functions

Service functions shall be protected by password or other suitable measures against unauthorized access. They shall not be selectable in **navigation mode**.

The requirements of chapters 5.1 to 5.3 are only applicable to **navigation mode**.

5.1 Static Correction of the Chart Position

(a) The position of the skipper's own vessel shall be presented "centred" or "off centred" on the display in accordance with the radar requirements. The chart position shall match the radar image. Assuming an absolute position's input, the permissible static difference between actual radar position and displayed radar centre shall not exceed 1 m;

(b) It shall be possible to correct an offset error (distance between the positions of the position sensor and the radar sensor).

5.2 Static Correction of the Chart Orientation

(a) The difference between the heading line orientation and the vessel's axis shall not be greater than ± 1.0 degree;

(b) Chart and radar image shall have the same orientation. The static directional error between heading line and chart orientation shall be less than ± 0.5 degree.

5.3 Configuration of Interfaces

(a) It shall be possible to configure interfaces for connected sensors, actors and signals;

(b) Interfaces shall comply with existing interface specifications as defined in IEC 61162 and the interface specifications for rate of turn indicators (20 mV/deg/min) as defined in IMO Resolution MSC.232(82).

6. Hardware test and Required Certificates

(a) The test shall consist of a comparison between the Equipment Under Test (EUT) and the requirements of this annex;

(b) Proved equivalent tests, and proved and documented test results shall be accepted without renewed tests;

(c) The entire chapter 6 is valid for navigation mode, but the requirements that do not contain a specific reference to navigation mode, are also valid for information mode.

6.1 Resistance to Environmental Conditions in Navigation Mode

(a) Inland ECDIS equipment, as described in chapter 2.2.4 of this section, shall fulfil the requirements of IEC 60945 concerning the resistance to environmental conditions (humidity, vibration and temperature; the latter reduced according to chapter 3.1 of this section) and concerning electromagnetic compatibility;

(b) The provider or his representative shall submit a relevant conformity declaration of an accredited laboratory.

6.2 Equipment Documentation

The technical documentation shall be checked to assure that it is complete, appropriate, and understandable, and that it is sufficient for unproblematic installation, configuration and operation of the equipment.

6.3 Interfaces

(a) All interfaces shall be documented correctly and completely;

(b) Electronic circuits shall be designed failsafe, mechanically as well as electronically, and shall not have degrading repercussions on connected equipment.

6.4 Characteristic of Operation Controls

All operation controls shall be checked regarding the ergonomic and functional mode of operation and shall fulfil the requirements of this annex.

6.5 Characteristic of the Display in Navigation Mode

The display shall fulfil all requirements of this annex concerning dimension, displayable colours, resolution and variation of brilliance.

7. Test of the Chart Presentation, Operation and Functionality

7.1 Preparation of the Equipment Under Test (EUT)

The EUT shall be installed, assembled and connected according to the installation manual. After switching on the test SENC shall be loaded.

7.2 Test of the Operation Modes

All operating modes as described in the operating manual shall be successively started up and tested. The requirements of chapter 4 of this section shall be fulfilled.

7.3 Test of the Displayed Features

Whether all features included in the test SENC are visible and correctly displayed, shall be tested. For this test, the information density shall be switched to "All Display". The system shall be capable to at least display all features according to the Presentation Standard for Inland ECDIS (section 3 of this annex). Additionally, other user-selectable symbol sets are allowed.

If symbols that deviate from appendix 2 "Status of the Presentation Library for Inland ECDIS" to this annex, are used for the presentation of any chart information, then they shall:

- be legible
- be certain and unambiguous in their meaning
- be of sufficient size to support the nominal viewing distance.

Symbols added to the ECDIS Presentation Library shall be clearly distinguishable from Presentation Library symbols.

7.4 Test of the Scale Dependent Information Density (SCAMIN)

(a) Whether the SCAMIN functionality (the minimum scale at which the feature may be used for ECDIS presentation) is installed correctly, shall be tested;

(b) For this test, the range shall be used at which the feature shall be visible according to its SCAMIN enumeration (refer to chapter 8.4 of appendix 1 "Product Specification for Inland ENCs", including appendices 1.1 "IENC Feature Catalogue" and 1.2 "Inland Electronic Navigational Chart Encoding Guide", to this annex).

7.5 Test of Brilliance Variation in Navigation Mode

The Inland ECDIS equipment shall be operated in a dark room and the brilliance shall be brought to its lowest level. The brilliance of the features shall not exceed a value of 15 cd/m², and the background a value of 0.5 cd/m².

7.6 Test of the Colours

All user selectable S-52 colour tables shall be sequentially tested to conform to this annex.

7.7 Test of the Measurement Functions

(a) All numeric display values of the electronic bearing line (EBL) and the variable range marker (VRM) shall exactly match with the analogue positions of EBL and VRM (or correspond with the cursor coordinates);

(b) The resolution and increments of the numerical display shall be identical with the analogue values of EBL and VRM.

7.8 Test of the Chart Update Function

Before and after each test step the version numbers of the loaded SENCs and updates shall be recalled as described in the operation manual and showed on the display.

- Step 1: Loading of the test SENC
- Step 2: Update of the test SENC
- Step 3: Test of the roll-back function
- Step 4: Loading of a new SENC.

After an update it shall be possible to recall and display all concerned features.

7.9 Test of Displayed Features in More than One Cell for the Same Area

(a) It shall be tested whether all features included in the test SENC and in the additional overlay test SENC are visible and correct displayed. For this test, the information density shall be switched to “All Display”;

(b) It shall be tested whether it is possible to select one or more specific cells for presentation, if there are several cells from different producers for the same area with the same usage;

(c) It shall be tested whether the test bathymetric Inland ENC is displayed correctly together with the base SENC in accordance with chapter 6 of appendix 2, “Status of the Presentation Library for Inland ECDIS” to this annex.

8. Test of Radar Picture Presentation and Operation in Navigation Mode

8.1 Preparations

(a) For the test purposes, the manufacturer or provider shall provide a serial interface at the system to be approved (equipment under test – EUT) which delivers the same actual values (as strings compliant with IEC 61162) of position and heading that are used to position and orient the chart;

(b) During the test, a reference system shall be used of which position and heading values are compared with those of the EUT;

(c) The EUT shall be connected to any type approved radar equipment (to the choice of the provider);

(d) The radar picture shall be adjusted in range and bearing with reference to the heading line.

8.2 Test of the Radar Picture without Under laid Chart

(a) If the Inland ECDIS equipment displays the radar picture but the radar operation control remains at the radar equipment (see figures 2 and 3 of section 4B), the radar picture of the Inland ECDIS equipment shall be considered as the “daughter display” of an item of radar equipment. In that case, the radar picture shall fulfil the display and picture-relevant requirements of the requirements for radar and rate-of-turn indicators;

(b) If the EUT is a radar installation with integrated Inland ECDIS functionality (see section 4B, figure 4), all requirements of the standards for radar equipment and rate-of-turn indicators shall be fulfilled.

8.3 Test of the Radar Picture, Overlaid Information from Other Vessels and the Underlying Chart

The Inland ECDIS equipment shall be installed in a reference environment. This may be real (on a vessel) or simulated. Position and orientation information of other vessels (according to the Inland AIS technical specifications) shall be applied with several information ages.

8.3.1 Test of the radar overlay

(a) The radar image shall not be degraded by the chart picture (refer to subparagraph (c) of chapter 4.3 of this section);

(b) The overlay of information regarding the position and orientation of other vessels shall be only displayed when:

- the information is up-to-date (nearly real-time), and
- the age of information does not exceed the maximum time out values provided in the first table in subparagraph (e) of chapter 5.1 of section 1 of this annex. The symbols shall be marked as outdated if the age of the information exceeds 30 seconds for moving vessels. The position information of the own vessel shall not be displayed, if it is received from a repeater station;

(c) The overlay of information derived from tracking and tracing devices regarding the position and orientation of other vessels shall be faded out at a user-definable range. The activation of this feature and the selected range of the restricted area shall be indicated on the display;

(d) If the heading of other vessels is available, the position and the orientation of other vessels shall be displayed by:

- a directed triangle; or
- a true outline (to scale).

For all other vessels a generic symbol shall be used (an octagon is recommended, a circle shall be used for inland applications only);

(e) It shall be possible to switch off the chart and any other information layer and to display only the radar picture by one easily accessible control element or menu area;

(f) The chart picture shall be renewed not later than the radar picture.

8.3.2 Test of the chart positioning and orientation

(a) The static offset of the chart position shall be less than ± 5 m in all ranges up to 2 000 m;

(b) The static azimuth orientation offset error between radar and chart image shall be less than ± 0.5 degree;

(c) The correction of these parameters referred to in subparagraphs (a) and (b) shall be demonstrated in the service mode;

(d) The dynamic deviation of the chart orientation at rates of turn less than ± 60 deg./min shall be less than ± 3 degree;

(e) These tests shall be performed visually or by evaluation of measured data.

8.3.3 *Test of scale conformity*

The chart's information shall be compared with well-known reference points contained in the radar picture in order to test whether the chart scale sufficiently conforms to the radar scale.

9. **Test of Alarms and Indications**

(a) The alarms generated from Inland ECDIS equipment itself as well as the passed alarms delivered to the ECDIS by the connected sensors shall be tested;

(b) The test procedure in **navigation mode** shall comprise the following situations:

- any error in the Inland ECDIS equipment (built-in test equipment – BITE)
- missing positioning signal
- missing radar signal
- missing rate-of-turn signal
- missing heading signal
- radar map matching not possible
- missing AIS signal;

(c) The test procedure in **information mode** shall comprise the following situations:

- any error in the Inland ECDIS equipment (built-in test equipment – BITE)
- missing positioning signal
- missing heading signal
- missing AIS signal.

The Inland ECDIS manufacturers have to confirm in their system documentation that the system includes those test procedures and signal indicators in information mode.

10. **Test of Fall-back Arrangements in Navigation Mode**

(a) This test shall demonstrate the reaction of the Inland ECDIS equipment to a failure of any internal or external component and the possible and required actions by the operator;

(b) In addition, the operating manual shall be checked to determine whether the measures required by the operator are described adequately and appropriately.

Section 4A: Measures to ensure Software Quality

1. General Requirements

Software used in **navigation mode** is a safety-relevant part of a navigation system. Providers of navigation systems shall make sure that all software components used in **navigation mode** allow safe navigation in every situation.

Requirements in chapters 1.1 to 1.5 are only applicable to **navigation mode**, while requirements in chapters 1.6 and 1.7 are applicable to both **navigation mode** and **information mode**.

1.1 Software Design Requirements

Software components shall be clearly designed by means of established software design methods. The design specification shall indicate how safety requirements are addressed in the software design.

A software style guide shall be provided that specifies code writing style, documentation style, modularization, conflict analyses and testing of software components. For every software component, documents describing specification and design are required.

1.2 Implementation Requirements

Implementation of software modules shall be done by qualified developers who fully understand the design and safety requirements.

If more than one developer is working on the navigation system software, a version control system shall be used that guarantees conflict-free development.

The implementation shall be according to the design specification and shall reflect the software style guide. Moreover, well-known implementation problems (depending on the language used) shall be addressed in the implementation. This includes but is not restricted to:

- null pointer handling
- un-initialized variables
- range checking
- array size verification
- memory allocation and de-allocation
- exception handling.

If parallel processing is used (e.g. multiple threads, tasks or processes), problems of conflict-free processing shall be addressed in the implementation. This includes but is not restricted to:

- race conditions
- re-entrance problems
- priority inversion
- deadlocks.

1.3 Test Requirements

In accordance with the design specification, software modules shall be tested. The test results shall be compared with the design guidelines and documented in test reports.

Tests shall incorporate module as well as system tests. Providers of a navigation system shall use extensive simulator-based tests to ensure stability of their system. The simulator shall allow the simulation of a complete navigation environment including all required external sensors.

1.4 Third Party Components Requirements

Third party components, such as OEM (Original Equipment Manufacturer) products, include software not developed by the navigation system provider. This includes but is not restricted to:

- static or dynamic linked libraries
- computer-aided design and engineering tools producing source or object code
- operating systems.

Third party software components shall be chosen according to the general safety requirements. The navigation system provider shall prove that third party components meet the high standards necessary for safe navigation either by providing acceptable quality certificates or by extensive and provable testing of the components.

1.5 Requirements for Additional Services in Navigation Mode

Navigation systems may support additional services in **navigation mode** if they are useful. These services shall not interfere with other requirement in navigation mode.

The navigation system provider is responsible for additional test equipment, necessary to verify interface specification, protocol specification and compliance tests with the Inland ECDIS technical specifications.

1.6 Language

Additional national versions of a type-approved Inland ECDIS shall reapply for type approval to be checked for the translation of the user interface. The type approval process is only foreseen for systems in navigation mode.

The qualified institution which performs the type approval process of an Inland ECDIS system, may request an expertise by a certified translator regarding the correct translation in a specific language from the system manufacturer.

1.7 Documentation Requirements for Users

The documentation (manuals) shall contain comprehensive information on the equipment, the installation, the operation and the service of the navigation system. The presentation of user-relevant information shall be clear, understandable and without unnecessary technical terms. The user manual shall at least be available in English, French, German and Dutch. The technical documentation may be made available in English only.

2. Methods of Testing and Required Test Results

2.1 Navigation Mode Operation Test

2.1.1 Performance Requirements

The navigation system shall make reliable estimations of position and heading. Moreover, the estimations of position and heading shall be checked by the system for conformity with the required accuracy.

Position and heading information shall be calculated and displayed for the same reference position. This shall normally be the centre of the radar antenna. A new position estimate shall at least be available with every revolution of the radar antenna.

2.1.1.1 Position

The navigation system shall estimate and display the position of the vessel. The following minimal requirements shall be fulfilled under normal operation conditions:

- (a) The average position estimation shall not deviate more than 5 metres from the true position and shall cover all systematic errors;

(b) The standard deviation σ shall be less than 5 metres and shall be based on random errors only;

(c) The system shall be capable to detect deviations of more than 3σ within 30 seconds.

These results shall be verified by a realistic test of at least 60 minutes.

2.1.1.2 Heading

The navigation system shall estimate and display the heading of the vessel. The following minimal requirements shall be fulfilled:

(a) The average heading angle estimation shall not deviate more than 1 degree from the radar heading direction and shall cover all systematic errors. The offset between vessel heading direction and radar heading shall be less than 1 degree;

(b) The standard deviation σ shall be less than 2 degrees and shall be only based on random errors.

These results shall be verified by a realistic test of at least 60 minutes.

2.1.2 *Sensor Failure*

The navigation systems shall check proper operation of the position and heading estimation online. Problems shall be detected within 30 seconds. In case of malfunction, the navigation system shall inform the user about the problem and its consequences for navigation.

If a critical sensor alarm signalizes that position or the heading does not meet the required accuracy criteria, the navigation chart shall be switched off.

2.1.3 *Performance Test Interface*

A navigation system provider shall equip navigation systems during the compliance test with a standard IEC 61162-1 interface sending the position and heading information used by the navigation system. This information shall be encoded by IEC 61162-1 sentences (see IEC 60945) known as GGA (Global Positioning System Fix Data) and HDT (Heading True). Additional sentences like RMC (Recommended Minimum Navigation Information), ROT (Rate of Turn) and VTG (Track made good and Ground speed) are accepted.

These strings shall be sent preferably every 0.1 second, at least every second. Position and heading shall be according to the definitions in chapters 2.1.1.1 and 2.1.1.2 of this section.

2.2 **General Software Tests**

2.2.1 *Equipment Documentation*

The following documents shall be provided for admittance and shall be shipped with every Inland ECDIS used in navigation mode:

- User's manual
- Installation manual
- Service manual.

The following documents and files shall be provided during the admittance procedure and are not required for end users:

- design specification
- software style guide
- certificates of third party software components or test and simulation protocols.

The documents and files provided shall allow for a complete verification of compliance with this annex.

A user's manual shall be shipped with every Inland ECDIS system.

2.2.2 *Endurance Test for navigation mode*

The navigation system shall pass an endurance test of 48 hours of uninterrupted operation under normal operating conditions. The system shall provide standard interfaces for performance and resource monitoring during operation. Monitoring the system shall show no indication of system instability, memory leaking or any kind of performance loss over time. Navigation systems supporting additional services while running in **navigation mode** shall provide the necessary test equipment including all documents mentioned in chapter 1.7 of this section.

3. Changes to Certified Navigation Systems

3.1 General Requirements

Navigation systems installed on board shall be functionally equivalent to a system certified by authorities. For every system, the navigation system provider shall ship a statement of compliance with the Inland ECDIS technical specifications and its functional equivalence to the certified system.

The competent authority is entitled to check Inland ECDIS compliance of installed systems at any time.

3.2 Hardware and Software Changes

The navigation system provider may change software or hardware as long as Inland ECDIS compliance is maintained. Changes shall be fully documented and submitted to the competent authority, together with an explanation of how the navigation system is affected by these changes. The competent authority may require a partial or complete renewal of certification if considered necessary. The aforementioned also applies to the use of an approved Inland ECDIS with another national version of the operating system.

The following changes do not affect certification of the system and require only a notice to the competent authority:

- minor changes on third party components (e.g. operation system or library updates)
- use of equivalent or better hardware components (e.g. faster microprocessor, newer chip revisions, equivalent graphic card, etc.)
- minor changes in source code or documentation.

Section 4B: System Configurations (Figures)

Figure 1
Inland ECDIS equipment, self-sufficient system without connection to radar (system configuration 1)

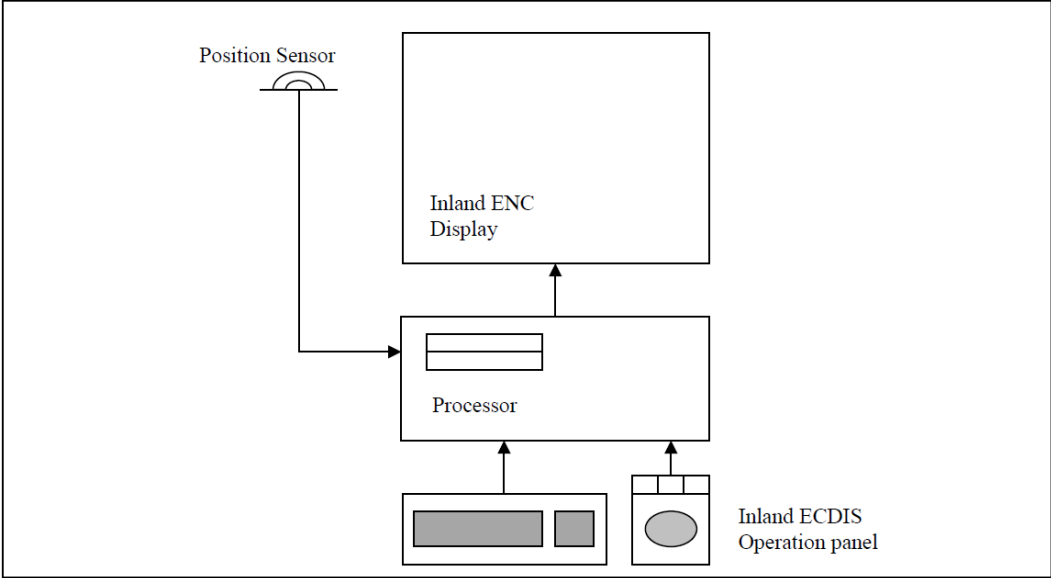

Figure 2
Inland ECDIS equipment, parallel installation with connection to radar (system configuration 2)

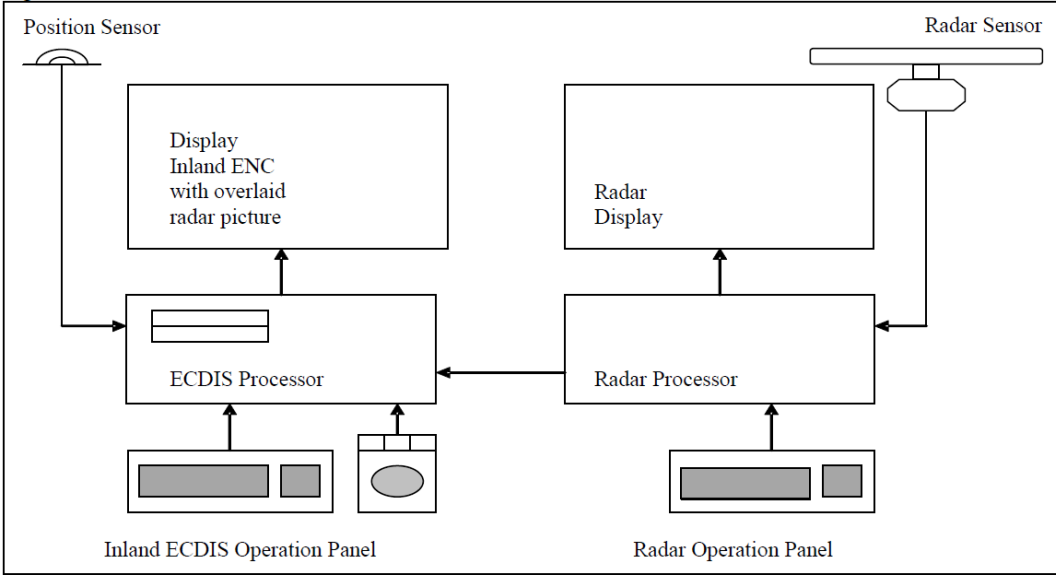

Figure 3
Inland ECDIS equipment with connection to radar and shared monitor (system configuration 3)

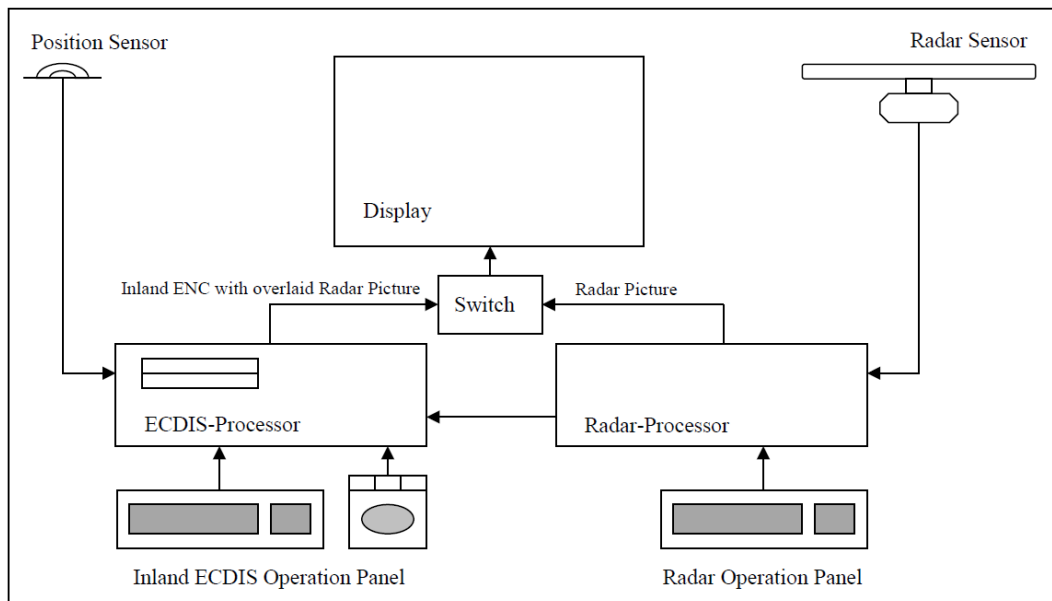
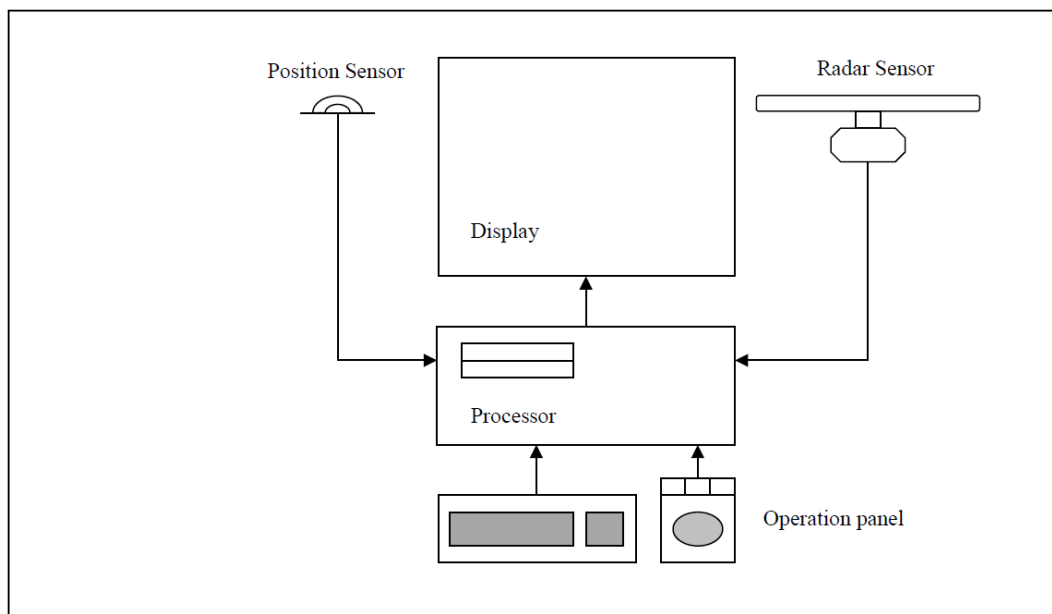

Figure 4
Navigational radar equipment with integrated Inland ECDIS functionality (system configuration 4)



Section 5: Glossary of Terms

<i>Term or abbreviation</i>	<i>Definition</i>	<i>Source</i>
Acronym	6-character-code of the feature/of the attribute.	S-57
Actor	An actor transforms an electrical quantity into another physical quantity (e.g. optical). An actor is the opposite of a sensor.	
AIS	On-board equipment allowing automatic identification of ships for enhanced ship monitoring as well as voyage data recording and other functions. The automatic identification system should comply with the technical and performance standards laid down in Chapter V of the International Convention for the Safety of Life at Sea, 1974 (SOLAS).	Resolution No. 57, revised
All information density	All information density (all display) means the maximum amount of SENC information. Here, in addition to the standard display (Standard Information Density), also all other objects are displayed, individually on demand.	Section 1 of this annex
Attribute	A defined characteristic of an entity (e.g. the category of a light, the sector limits, the light characteristics etc.). Definitions for diverse attributes may be derived from the Feature Catalogue for Inland ENC's referred to Appendix 1 "Product Specification for Inland ENC's" to this Annex.	S-57
Cell (chart cell)	A cell is a geographical area containing Inland ENC or bathymetric Inland ENC data.	S-57
CIE colour calibration	Procedure to confirm that the colour specified in S-52 is correctly reproduced on the ECDIS display.	S-52 and S-32
Datum	A set of parameters specifying the reference surface or the reference coordinate system used for geodetic control in the calculation of coordinates of points on the earth. Commonly datums are defined as horizontal and vertical datums separately. For the practical use of the datum it is necessary to have one or more well distinctive points with coordinates given in that datum. The horizontal datum is a set of parameters specifying the reference for horizontal geodetic control, commonly the dimensions and the location of a reference ellipsoid. (The horizontal datum must be compliant with WGS 84.) The vertical datum is a surface to which elevations and/or depths (soundings and tide heights) are referred. For elevations commonly a level (equipotential) surface, approximately the mean sea level is used, for depths in many cases low water.	S-52, S-32 and IEHG Product Specification for Inland ENC's
Display base	Minimum information density; means the minimum amount of SENC information that is presented and which cannot be reduced by the operator, consisting of information that is required at all times in all geographic areas and under all circumstances.	IMO Resolution MSC.232(82)
Display scale	The ratio between a distance on the display and a distance on the ground, normalised and expressed as a ratio, e.g. 1:10 000.	S-52 and S-32
EBL	Electronic Bearing Line.	Section 4 of this annex
ECDIS	Electronic Chart Display and Information System (ECDIS) means a navigation information system which with adequate back-up arrangements can be accepted as complying with the up-to-date chart required by regulations V/19 and V/27 of the SOLAS Convention, as amended, by displaying selected information from SENC with positional information from navigation sensors to assist the mariner in	IMO Resolution MSC.232(82)

<i>Term or abbreviation</i>	<i>Definition</i>	<i>Source</i>
	route planning and route monitoring, and if required display additional navigation-related information.	
Edge	A one-dimensional spatial object, located by two or more coordinate pairs (or two connected nodes) and optional interpolation parameters.	S-57
Electronic chart	Very broad term to describe the data, the software, and the electronic system, capable of displaying chart information. An electronic chart may or may not be equivalent to the paper chart required by the SOLAS Convention.	S-52 and S-32
ENC	Electronic Navigational Chart; the data base, standardised as to content, structure and format, issued for use with ECDIS on the authority of government authorised hydrographic offices. The ENC contains all the chart information necessary for safe navigation and may contain supplementary information in addition to that contained in the paper chart (e.g. sailing directions) which may be considered necessary for safe navigation.	IMO Resolution MSC.232(82)
ENC cell	The geographic division of ENC data for distributing purposes.	IEC Guideline 61174, edition 3.0
ETSI	European Telecommunications Standards Institute	
Enumeration	A specific quality or quantity assigned to an attribute (e.g. 'leading light', the limiting angles, the code specifying the light's colour — see attribute).	IEHG Inland ENC Feature Catalogue
Feature	An identifiable set of information. A feature may have attributes and may be related to other features. A digital representation of all or a part of an entity by its characteristics (attributes), its geometry, and (optionally) its relationships to other features (e.g., the digital description of a light sector specifying, amongst others, sector limits, the colour of the light, the visibility range, etc., and a link to a light tower, if any). Definitions for diverse features may be derived from the Feature Catalogue for Inland ENCs referred to in Appendix 1 to this Annex.	S-52 and S-32
Feature catalogue	The comprehensive list of currently identified features, attributes and enumerations which are allowed for the use in Inland ENCs.	IEHG Inland ENC Feature Catalogue
File	An identified set of S-57 records collected together for a specific purpose. The file content and structure must be defined by a product specification.	S-52 and S-32
GNSS	Global Navigation Satellite System (GNSS) is a system that uses satellites to provide autonomous geospatial positioning.	
Heading	The direction in which the longitudinal axis of a craft is pointed, usually expressed as an angular distance from north clockwise through 360 degrees (true, magnetic or compass).	S-52 and S-32
Head-up display	The information shown on the display (radar or ECDIS) is directed so that the vessel's heading is always pointing upward. This orientation corresponds to the visual view from the bridge in direction of the vessel's heading. This orientation may require frequent rotations of the display content. Changing the vessel's course or yawing of the vessel may render this unstabilised orientation mode illegible.	S-52 and S-32
Human Machine Interface (HMI)	The user interface or human-machine interface is the part of the machine that handles the human-machine interaction. The engineering	

<i>Term or abbreviation</i>	<i>Definition</i>	<i>Source</i>
	of the human-machine interfaces is enhanced by considering ergonomics (human factors). There are many ways to develop human-machine interface (HMI) screens for machine and process automation applications. Guidelines, standards and handbooks covering the HMI design include those published by ISA, ASM, ISO, and NUREG.	
IEC	International Electrotechnical Commission: An international (non-governmental) organization which produces world standards for electrical and electronic engineering with the objective of facilitating international trade.	S-52 and S-32
IHO	International Hydrographic Organization: Coordinates the activities of national hydrographic offices; promotes standards and provides advice to developing countries in the fields of hydrographic surveying and production of nautical charts and publications.	S-52 and S-32
IHO registry	IHO Geospatial Information Infrastructure Registry. A registry is the information system on which a register is maintained. In the case of S-100 IHO hosts a registry that provides a facility to store various registers of hydrographic-related information.	IENC Domain in the S-100 Registry
IMO	International Maritime Organization: Formerly called IMCO, IMO is the specialized agency of the United Nations responsible for maritime safety, efficiency of navigation and prevention of marine pollution from ships.	S-52 and S-32
Information Mode	Means the use of the Inland ECDIS for information purposes only without overlaid radar image.	Section 1 of this annex
Inland AIS	Automatic identification system for inland waterway vessels as set out in the International Standard for Tracking and Tracing on Inland Waterways (VTT) (resolution No. 63).	International Standard for Tracking and Tracing on Inland Waterways (VTT) (resolution No. 63)
Inland ECDIS	An Electronic Chart Display and Information System for inland navigation, displaying selected information from an Inland System Electronic Navigational Chart (Inland SENC) and optionally, information from other navigation sensors.	Section 1 of this annex
Inland ENC (IENC)	Inland Electronic Navigational Chart (IENC) means the database, standardised as to content, structure and format, for use with inland electronic chart display and information systems operated on-board of vessels transiting inland waterways. An IENC is issued by or on the authority of a competent government agency, and conforms to standards initially developed by the International Hydrographic Organization (IHO) and refined by the Inland ENC Harmonization Group. An IENC contains all the chart information necessary for safe navigation on inland waterways and may contain supplementary information in addition to that contained in the paper chart (e.g. sailing directions, machine-readable operating schedules, etc.) which may be considered necessary for safe navigation and voyage planning.	Section 1 of this annex
Inland ENC domain	Domain within the IHO Geospatial Information Infrastructure Registry dedicated for Inland ENC-related entries.	IENC Domain in the S-100 Registry
Inland SENC	Inland System Electronic Navigational Chart: a database resulting from the transformation of the Inland ENC by Inland ECDIS for appropriate use, updates to the Inland ENC by appropriate means and other data added by the mariner. It is this database that is actually accessed by the Inland ECDIS for the display generation and other	Section 1 of this annex

<i>Term or abbreviation</i>	<i>Definition</i>	<i>Source</i>
	navigational functions. The Inland SENC may also contain information from other sources.	
Integrated display	Means a head-up, relative-motion picture consisting of the Inland SENC overlaid with the radar-image with matching scale, offset and orientation.	Section 1 of this annex
Look-up table	A table giving symbology instructions to link SENC objects to point, line or area symbolisation and providing display priority, radar priority, IMO category and optional viewing group.	S-52 and S-32
Navigation mode	Means the use of the Inland ECDIS for conning the vessel with overlaid radar image.	Section 1 of this annex
North-up display	Information shown on the display (radar or ECDIS) with the north direction upward.	S-52 and S-32
Other navigational information	Navigational Information not contained in the SENC, that may be displayed by an ECDIS, such as radar information.	S-52 and S-32
Own vessel	The term which identifies the vessel upon which an ECDIS is operating.	S-52 and S-32
Own vessel's safety contour	The contour related to the own vessel selected by the mariner from the contours provided for in the SENC, to be used by ECDIS to distinguish on the display between the safe and the unsafe water, and for generating anti-grounding alarms.	S-52 and S-32
Performance standard for ECDIS	Standard developed under the authority of IMO to describe the minimum performance requirements for navigational devices and other fittings required by the SOLAS Convention, included in MSC.232(82), as adopted by IMO on 5 December 2006.	S-52 and S-32
Pick report (feature report)	The result of querying a displayed point-symbol, line or area for further information from the data base which is not represented by the symbol.	S-52 and S-32
Presentation library for ECDIS	A set of mostly digital specifications, composed of symbol libraries, colour schemes, look-up tables and rules, linking every feature and attribute of the SENC to the appropriate presentation of the ECDIS display. Published by IHO as Annex A, Special Publication No 52 (S-52).	S-52 and S-32
Product specification	A defined subset of the entire specification combined with rules, tailored to the intended usage of the transfer data. (The ENC Product specification specifies the content, structure and other mandatory aspects of an ENC)	S-52 and S-32
(Radar) range	Distance from the radar antenna. For inland navigation the radar range has to be sequential switchable according to the Radar Regulations.	Annex II of Directive 2016/1629 of the European Parliament and of the Council of 14 September 2016 laying down technical requirements for inland waterway vessels
Relative motion display	A relative motion display shows the chart information and radar targets moving relative to the vessel position fixed on the screen.	S-52 and S-32

<i>Term or abbreviation</i>	<i>Definition</i>	<i>Source</i>
Route planning	An ECDIS function in which the area is displayed which is needed to study the intended route, to select the intended track, and to mark the track, its way points and navigational notes.	IMO Resolution MSC.232(82)
SCAMIN	The minimum scale at which the feature may be used e.g. for ECDIS presentation.	S-57
SENC	System Electronic Navigational Chart: An internal data base in an Inland ECDIS which results out of the transformation of ENC's and their update files and other data added by the boatmaster. It is this data base that is actually accessed by the ECDIS for the display generation and other navigational functions. The SENC may also contain information from other sources.	S-52 and S-32
Spatial object	An object which contains locational information about real world entities.	S-52 and S-32
Standard Information Density	The default amount of SENC information that shall be visible when the chart is displayed when ECDIS is switched on. A screen with Standard Information Density (standard display) is the default state of the Inland ECDIS.	Section 1 of this annex
[Vessel] Tracking and Tracing	Tracking: function of maintaining status information on the vessel, possibly combined with information on cargo and consignments; tracing: retrieval of information concerning the whereabouts of the vessel, possibly combined with information on cargo, consignments and equipment, as set out in the International Standard for Tracking and Tracing on Inland Waterways (VTT) (resolution No. 63).	International Standard for Tracking and Tracing on Inland Waterways (VTT) (resolution No. 63)
True motion display	A display in which the own vessel and each radar target moves with its own true motion, while the position of all charted information remains fixed.	S-52 and S-32
User-defined settings	Means the possibility to use and store a profile of display and operation controls- settings.	Section 1 of this annex
VRM	Variable Range Marker.	Section 4 of this annex
WGS 84	World Geodetic System: The geodetic basis for the 'Navigational Satellite Timing and Ranging — Global Positioning System', which enables the surveying of the earth and its entities and was developed by the United States Department of Defence. This global geodetic reference system is recommended by IHO for hydrographic and cartographic use.	IEHG Product Specification for Inland ENC's

Appendix 4

Comparison of the structures of the standard for (Maritime) ECDIS and of the technical specifications for Inland ECDIS

<i>(Maritime) ECDIS</i>	<i>Inland ECDIS</i>	<i>OPEN ECDIS FORUM</i> <i>http://ienc.openecdis.org</i>
IMO MSC.232(82) revised Performance Standards for Electronic Chart Display and Information Systems (ECDIS), December 2006	Section 1: Performance Standard	
Appendix 1: Reference Documents		
Appendix 2: SENC Information available for display during route planning and route monitoring		
Appendix 3: Navigational Elements and Parameters		
Appendix 4: Areas for which special conditions exist		
Appendix 5: Alarms and Indicators		
Appendix 6: Back-up requirements		
Appendix 7: RCDS mode of operation		
IHO S-57: Transfer Standard for Digital Hydrographic Data, edition 3.1 (including Supplement No. 2, June 2009)	Section 2: Data Standard for Inland ENC's	
Part 1: General Introduction		Inland ENC Feature Catalogue
Part 2: Theoretical Data Model		
Part 3: Data Structure		Bathymetric Inland ENC Feature Catalogue
Appendix A: IHO Object Catalogue		
Chapter 1: Object Classes		Product Specification for Inland ENC's
Chapter 2: Attributes		
Annex B: Attributes/Object Classes Cross Reference		Product Specification for bathymetric Inland ENC's
Appendix B: Product Specifications		
Appendix B.1: ENC Product Specification		
Annex A: Use of the Object Catalogue for ENC		IENC Encoding Guide
Annex B: Example of CRC Coding		
Appendix B.2: IHO Object Catalogue Data Dictionary Product Specification		
IHO S-62 ENC Producer Codes, edition 2.5, December 2009	Section 2A: Codes for Producers and Waterways	OEF (www.openecdis.org): Codes for Producers and Waterways (not part of the Inland ECDIS technical specifications)
IHO S-52 Specification for Chart Content and Display Aspects of ECDIS, edition 6, March 2010	Section 3: Presentation Standard	Presentation Library for Inland ECDIS
Annex A: IHO ECDIS Presentation Library		Look-up Tables

<i>(Maritime) ECDIS</i>	<i>Inland ECDIS</i>	<i>OPEN ECDIS FORUM</i> <i>http://ienc.openecdis.org</i>
Annex B:	Procedure for initial calibration of colour displays	Symbols
Annex C:	Procedure for maintaining the calibration of displays	Conditional Symbology Procedures
Appendix 1:	Guidance on Updating the Electronic Chart	
Annex A:	Definitions and Acronyms	
Annex B:	Current Updating Practice for Paper Charts	
Annex C:	Estimate of Data Volume	
	IEC 61174 edition 3.0: ECDIS – Operational and Performance Requirements, Methods of Testing and Required Test Results, 2008	Section 4: Operational and Performance Requirements, Methods of Testing and Required Test Results Section 4A: Measures to Ensure Software Quality Section 4B: System Configurations
IHO S-32 Appendix 1: Hydrographic Dictionary – Glossary of ECDIS-Related Terms		Section 5: Glossary of Terms