



Economic Commission for Europe**Inland Transport Committee****World Forum for Harmonization of Vehicle Regulations****179th session**

Geneva, 12-14 November 2019

Item 4.8.7 of the provisional agenda

1958 Agreement:**consideration of draft amendments to existing
UN Regulations submitted by GRSP****Proposal for Supplement 3 to the 03 series of amendments to
UN Regulation No. 129 (Enhanced Child Restraint Systems)****Submitted by the experts from the Working Party on Passive Safety***

The text reproduced below was adopted by the Working Party on Passive Safety (GRSP) at its sixty-fifth session (ECE/TRANS/WP.29/GRSP/65, para. 34). It is based on ECE/TRANS/WP.29/GRSP/2019/12, as amended by Annex V to the report. It is submitted to the World Forum for Harmonization of Vehicle Regulations (WP.29) and to the Administrative Committee (AC.1) for consideration at their November 2019 sessions.

* In accordance with the programme of work of the Inland Transport Committee for 2018–2019 (ECE/TRANS/274, para. 123 and ECE/TRANS/2018/21/Add.1, Cluster 3.1), the World Forum will develop, harmonize and update UN regulations to enhance the performance of vehicles. The present document is submitted in conformity with that mandate.

Supplement 3 the 03 series of amendments to UN Regulation No. 129 (Enhanced Child Restraint Systems)

Table of contents, insert the references to new Annexes 25 and 26, to read:

"25	Device to measure the booster cushion height
26	Lower torso body block test..... "

Text of the Regulation,

Paragraph 1., amend to read:

"1. Scope

This Regulation applies to the following child restraint systems for child occupants of power driven vehicles:

...

- (f) Integral Specific vehicle Belted Enhanced Child Restraint Systems;
- (g) Non-integral Universal Enhanced Child Restraint Systems without a backrest (Universal booster cushion);
- (h) Non-integral Specific vehicle Enhanced Child Restraint Systems without a backrest (Specific vehicle booster cushion)."

Insert new paragraph 2.3.4., to read:

"2.3.4. "Universal booster cushion" (Non-Integral Universal Enhanced Child Restraint System without a backrest) is a category of Enhanced Child Restraint System without a backrest primarily designed for use in all i-Size and all Universal seating positions. If fitted, ISOFIX attachments are stowable."

Insert a new paragraph 2.7.4., to read:

"2.7.4. "Specific vehicle booster cushion" (Non-Integral Universal Enhanced Child Restraint System without a backrest) is a category of Non-Integral Enhanced Child Restraint System, without a backrest, for use in specific vehicle types, with vehicle anchorages which are approved according to UN Regulation No. 14 or UN Regulation No. 145. This category includes "Built-in booster cushions"."

Paragraph 2.17.2., amend to read:

"2.17.2. "i-Size booster fixture" means a fixture, of the dimensions given in figure 1 of Annex 17, Appendix 5 of Regulation No. 16 and used by an Enhanced Child Restraint System manufacturer to determine the appropriate dimensions of an i-Size booster seat or Universal booster cushion and its compatibility with most vehicle seating positions and, in particular, those which have been assessed without ISOFIX attachments, according to Regulation No. 16 as being compatible with such a category of an Enhanced Child Restraint System."

Paragraph 3.2.2., amend to read:

- "3.2.2. The applicant shall indicate the kind of application:
- (a) Application for a i-Size Enhanced Child Restraint Systems; or
 - (b) Application for a specific vehicle ISOFIX Enhanced Child Restraint System; or
 - (c) Application for a i-Size booster seat Enhanced Child Restraint System; or
 - (d) Application for a specific vehicle booster seat Enhanced Child Restraint System;

- (e) Application for a Universal Belted Enhanced Child Restraint System; or
- (f) Application for a Specific vehicle Belted Enhanced Child Restraint Systems; or
- (g) Application for a Universal booster cushion Enhanced Child Restraint System; or
- (h) Application for a Specific vehicle booster cushion Enhanced Child Restraint System; or
- (i) Any combination of (a), (b), (c), (d), (g) and (h) as long as they fulfil paragraphs 5.4.2.2., 6.1.2. and 6.1.3. provided there is only one belt route; or
- (j) Any combination of (c), (d), (e), (f), (g) and (h) as long as they fulfil paragraphs 5.4.2.2., 6.1.2. and 6.1.3. provided there is only one belt route and that the booster seat and booster cushion is not equipped with ISOFIX connectors."

Paragraph 4.8.1., amend to read:

- "4.8.1. i-Size booster seat Enhanced Child Restraint Systems shall have a permanently attached label of the i-Size logo according to paragraph 4.7.1. visible to the person installing the Enhanced Child Restraint System in the car."

Insert new paragraphs 4.8.3. to 4.8.5., to read:

- "4.8.3. Universal booster cushion Enhanced Child Restraint Systems shall have a permanently attached label with the following information visible to the person installing the Enhanced Child Restraint System in the car:

Universal booster cushion



- 4.8.4. Specific vehicle booster cushion Enhanced Child Restraint Systems (except built-in) shall have a permanently attached label with the following information visible to the person installing the Enhanced Child Restraint System in the car:



Specific vehicle booster cushion

- 4.8.5. Booster cushion Enhanced Child Restraint Systems shall have the following label (Minimum size: 60 x 40 mm) permanently attached and visible to the person installing the Enhanced Child Restraint System in the car. The limit X shown on the label represents the lower stature of the size range the Enhanced Child Restraint System is approved to. If the booster cushion is approved in combination with a booster seat the label shall be visible only when the ECRS is used as a booster cushion.

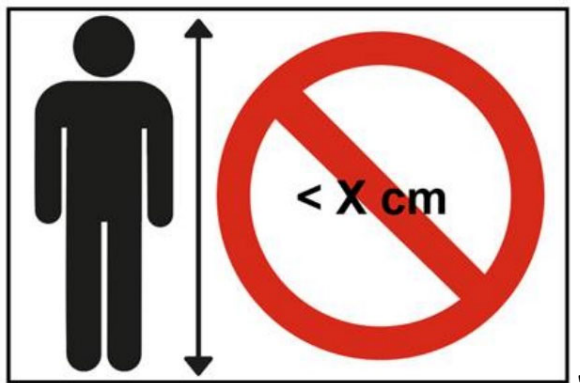

Insert new paragraph 4.11., to read:

- "4.11. A Booster seat that converts to a Booster cushion by a removable backrest, shall have a permanently attached label on the backrest, to indicate the brand and model of the Enhanced Child Restraint System to which it belongs and the size range. The minimum size of the label shall be 40 x 40 mm or the equivalent area."

Paragraphs 4.11. to 4.12. (former), renumber as paragraphs 4.12. to 4.13.

Paragraph 6.1.1., amend to read:

- "6.1.1. ...
Enhanced Child Restraint Systems in the i-Size booster seat category are primarily designed for use in all i-Size seating positions. The instructions of an i-Size booster seat may declare use in any Universal seating position provided that it does not conflict with the interior of the car.

Enhanced Child Restraint Systems in the Universal booster cushion category are designed for use in all i-Size and all Universal seating positions.

Enhanced Child Restraint Systems in the specific vehicle ISOFIX category are for use in all ISOFIX positions and also in the luggage area, if the restraints are fitted in conformity with the vehicle manufacturer's instructions.

Enhanced Child Restraint Systems in the specific vehicle booster seat or specific vehicle booster cushion category are to be used according to manufacturer's instructions."

Paragraphs 6.1.3.1. to 6.1.3.3., amend to read:

- "6.1.3.1. For the i-Size booster seat and Universal booster cushion categories, by means of the adult safety seat belt and possibly with optional ISOFIX attachments, if the ISOFIX attachments are stowable (see Regulation No. 16, Annex 17, Appendix 5, Figure 1, Detail B).

6.1.3.2. For the specific vehicle booster seat and specific vehicle booster cushion categories, by means of the adult safety seat belt and possibly with attachments designed by the manufacturer of the Enhanced Child Restraint System, secured to anchorages as designed by the vehicle manufacturer. Only ISOFIX attachments shall be used in conjunction with ISOFIX anchorage system."

Table 2
Possible configurations of Non-Integral Enhanced Child Restraint Systems for type approval

	<i>Orientation</i>	<i>Category</i>			
		i-size booster seat	Universal booster cushion	Specific vehicle booster seat (built in included)	Specific vehicle booster cushion (built in included)
Non-integral	Forward Facing	A	A	A	A
	Rearward Facing	N/A	N/A	N/A	N/A
	Lateral Facing	N/A	N/A	N/A	N/A

A: Applicable

N/A: Non-applicable"

Paragraphs 6.1.3.4. and 6.1.3.5., amend to read:

"6.1.3.4. Enhanced Child Restraint Systems of the booster seat and booster cushion categories shall have a main load-bearing contact point, between the Enhanced Child Restraint System and the adult safety belt. This point shall not be less than 150 mm from the Cr axis when measured with the Enhanced Child Restraint System on the dynamic test bench installed in accordance with paragraph 7.1.3.5.2.2. of this Regulation, without a dummy. This shall apply to all adjustment setups and webbing paths.

6.1.3.5. The adult seat belt required to secure belted Enhanced Child Restraint Systems on the dynamic test bench is defined in Annex 22 to this Regulation.

..."

Insert a new paragraph 6.1.3.6., to read:

"6.1.3.6. For booster cushions, type approval shall not be granted for a stature below 125 cm. Booster cushions shall not be declared for use below a stature of 125 cm.

Booster cushions shall ensure that the top of the child's head is at or above a horizontal plane at 770 mm vertically from the Cr axis when seated on the test bench described in Annex 6.

The procedure to check if a booster cushion fulfils this requirement is outlined as follows (See figure 1 below):

Figure 1
Measurement device to check the Sitting Height

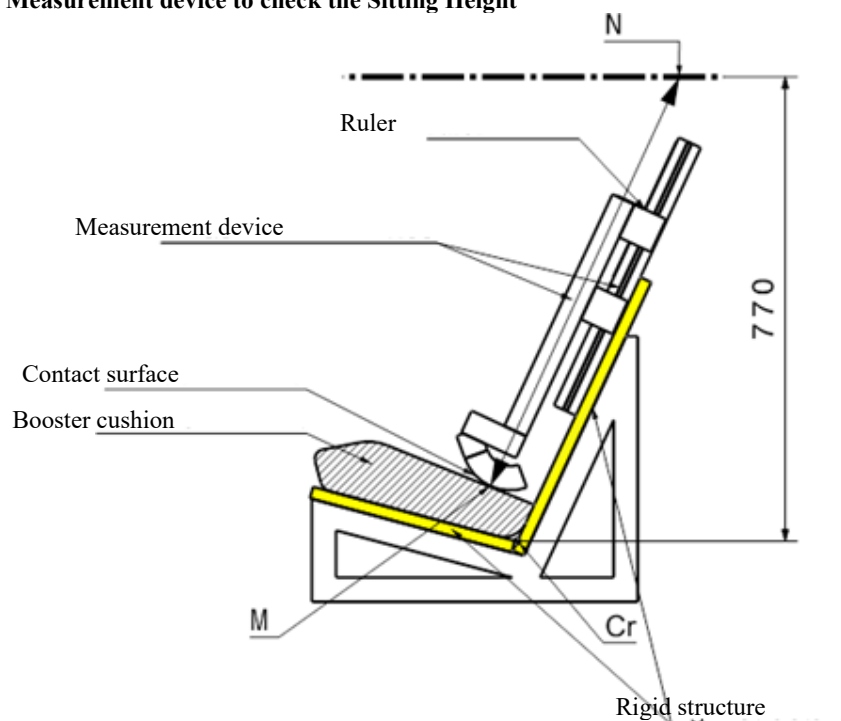

- (a) A simulated test bench shall be used for the assessment. The simulated bench shall have the same geometry as the test bench defined in Annex 6 of this Regulation, including the seat cushions. However, the width of the simulated bench may be reduced, if the width is between 500 and 800 mm, as shown in Annex 25. The simulated test bench shall be of rigid construction and shall not deform when using the measuring device defined in Annex 25.
- (b) A rigid structure is attached to the simulated test bench and holds a sliding part. A horizontal plane that is located at a vertical distance of 770 mm from the Cr axis is defined.
- (c) The booster cushion shall be placed on the simulated test bench with its centreline aligned with the centreline of the test bench and the rear surface of the booster cushion contacting the backrest of the test bench.
- (d) If ISOFIX attachments are present these shall be latched with the test bench lower ISOFIX anchorages. An additional force of $135 \pm 15\text{N}$ shall be applied in a plane parallel to the surface of the simulated test bench. The force shall be applied along the centreline of the Enhanced Child Restraint System and at a height of no more than 100 mm above the simulated test bench seat surface.
- (e) The measurement device is extended downwards parallel to the simulated test bench backrest, until it is stopped by the booster seat cushion.

Figure 2
Ruler of measurement device

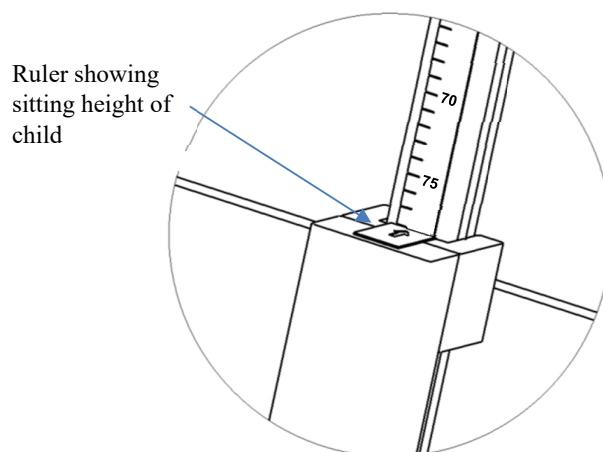

- (f) The measured distance between the two points M and N (Figure 1) represents the sitting height of a child who will use the booster cushion. The corresponding value is displayed by a ruler that is provided with the device as shown in Figure 2.
- (g) Using the data in Table 3, the sitting height is utilized to determine the corresponding minimum stature of the child that can be accommodated by the booster cushion. Example: A sitting height of 66.2 cm shall correspond to a child minimum stature of 125 cm; a sitting height of 75.9 cm shall correspond to 150 cm.
- In case the value obtained for the sitting height is between two integer values always round up to the next integer value (e.g. Measured sitting height = 70.1 cm ► resulting stature = 135.65 cm ► Smallest stature allowed = 136 cm).
- (h) The stature determined in this procedure shall be compared to the lower limit of the approval stature range. The requirement is fulfilled if the lower approval stature is greater or equal than the obtained minimum stature.

Table 3
Sitting heights with corresponding minimum statures

<i>Minimum Sitting Height 50th percentile³ (cm)</i>	<i>Stature (cm)</i>
66.2	125
67.9	130
69.7	135
71.6	140
73.6	145
75.9	150

Note: For statures in between the displayed values the respective sitting height needs to be calculated by means of a linear interpolation."

³ Anthropometric Reference Database France, Volume III: Statistical Results for 0 to 17-year old Children, Children equipment and Accessories. IFTH, Cholet, France, page 525

Paragraph 6.2.1.5., amend to read:

"6.2.1.5. All restraint ... to excessive stresses.

In the case of non-integral Enhanced Child restraint Systems, the lap portion of the adult safety-belt shall be positively guided on both sides to ensure that the loads transmitted by the adult lap belt are transmitted through the pelvis.

..."

Paragraph 6.3.2.1., amend to read:

"6.3.2.1. Internal geometric characteristics

The Technical Service conducting the approval tests shall verify that the internal dimensions of the Enhanced Child Restraint System conform to the requirements of Annex 18. The minimum dimensions for shoulder breadth, hip breadth and sitting height shall be fulfilled simultaneously for any stature within the size range declared by the manufacturer.

...

Booster seats shall also fulfil the maximum dimensions of shoulder height, for any stature within the size range declared by the manufacturer.

Booster cushions shall fulfil the minimum dimensions of hip breadth for the largest stature of the size range declared by the manufacturer. No other internal dimensions are applicable for booster cushions provided the requirements of paragraph 6.1.3.6. are met."

Paragraph 6.3.2.2., amend to read:

"6.3.2.2. External dimensions

The Technical Service conducting the approval tests shall verify that the external dimensions of the Enhanced Child Restraint System conform to the requirements of paragraphs 6.3.2.2.1., 6.3.2.2.2. and 6.3.2.2.3. as applicable.

Paragraph 6.3.2.2.2., amend to read:

"6.3.2.2.2. Booster Seats

The maximum external dimensions for the width, height and depth of the Enhanced Child Restraint System and the locations of the ISOFIX anchorages system if any, with which its attachments shall engage, shall be defined by the i-Size booster fixture as defined in paragraph 2.17.2. of this Regulation.

- (a) i-Size booster seat Enhanced Child Restraint Systems shall fit within the ISO/B2 size envelope;
- (b) Specific vehicle booster seat Enhanced Child Restraint Systems shall fit:
 - (i) In vehicle(s) specified in a list; or
 - (ii) At least in one of ISO/B2 –ISO/B3 size envelope as described in Annex 17, Appendix 5 of UN Regulation No. 16.

When conducting this assessment, the booster seat shall be adjusted to accommodate children of 135 cm stature (height, depth and width dimensions as defined in Annex 18) or to the largest size of its declared stature range if the upper limit is below 135 cm.

The booster seat shall fit within the booster seat fixture in all angles of inclination of the fixture (90°-110°). The Enhanced Child Restraint System may be adjusted between inclination angles or positions to fit within the different booster seat fixture angles.

If other positions of inclination are outside the limits of the applicable size envelope, the user manual shall indicate that the child restraint may not fit in all approved vehicles when used in one of these positions. If the booster seat has a declared stature range above 135 cm, and if it is necessary to adjust the

child restraint outside the limits of the applicable size envelope for such adjustments (height, depth and width dimensions), the user manual shall indicate that the child restraint may not fit in all approved vehicles when used in one of these positions."

Insert a new paragraph 6.3.2.2.3., to read:

"6.3.2.2.3. **Booster Cushions**

The maximum external dimensions for the width, height and depth of the Enhanced Child Restraint System and the locations of the ISOFIX anchorages system if any, with which its attachments shall engage, shall be defined by the i-Size booster fixture as defined in paragraph 2.17.2. of this Regulation.

- (a) Universal booster cushion Enhanced Child Restraint Systems shall fit in the ISO/B2 size envelope;
- (b) Specific vehicle booster cushion Enhanced Child Restraint Systems shall fit:
 - (i) In vehicle(s) specified in a list; or
 - (ii) At least in one of ISO/B2 or ISO/B3 size envelopes as described in Annex 17, Appendix 5 of regulation No. 16."

Paragraph 6.3.3.1., the reference to figure 0(a) and figure 0(a), renumber as figure 3(a)

Paragraph 6.3.3.2., the reference to figure 0(b) and figure 0(b), renumber as figure 3(b)

Paragraph 6.3.4.1., the reference to figure 0(c) and figure 0(c), renumber as figure 3(c)

Paragraph 6.3.4.2.3., the reference to figure 0(c) and figure 0(c), renumber as figure 3(c)

Paragraph 6.3.5., the reference to footnote ³ and footnote ³, renumber as footnote ³

Paragraph 6.3.5.3., the reference to figure 0(d) and figure 0(d), renumber as figure 3(d)

Paragraph 6.3.5.4., the reference to figure 0(e) and figure 0(e), renumber as figure 3(e)

Paragraph 6.6.4.1., the reference to table 2 and table 2, renumber as table 3

Paragraph 6.6.4.1.2.2., amend to read:

"6.6.4.1.2.2. For Enhanced Child Restraint Systems which are in conformity with paragraph 6.3. of this Regulation (for example ECRS using no anti-rotation device or using additional anchorages) or do not fit in any envelope defined in Regulation No. 16, Annex 17, Appendix 2 or Appendix 5, on the test trolley in a vehicle body shell in conformity with paragraph 7.1.3.2. or in a complete vehicle in conformity with paragraph 7.1.3.3. of this Regulation."

Paragraph 6.6.4.1.3., amend to read:

"6.6.4.1.3. The dynamic test shall be performed on Child Restraint Systems which have not previously been under load. The Enhanced Child Restraint System of the i-Size booster seat and Universal booster cushion categories shall be tested on the test bench described in Annex 6, and in conformity with paragraph 7.1.3.1. below."

Paragraph 6.6.4.4.1.1., amend to read:

"6.6.4.4.1.1. **Forward facing Enhanced Child Restraint Systems**

Integral Enhanced Child Restraints: No part of the head of the dummy shall pass beyond the planes BA, DA and DE as defined in Figure 1 below:

- (a) The value in relation to the BA plane is 500 mm; and
- (b) The value in relation to the DA plane is 800 mm; and
- (c) However, the head of the dummy may pass beyond the DE plane, if the head pad or the backrest part of the child restraint structure, which is behind the head of the dummy, at the point the head, passes the DE plane.

This shall be judged up to 300 ms or the moment that the dummy has come to a definitive standstill, whatever occurs first.

Non-integral booster seat: No part of the head of the dummy shall pass beyond the planes BA and DA as defined in Figure 1 below.

This shall be judged up to 300 ms or the moment that the dummy has come to a definitive standstill, whatever occurs first.

When testing with the Q10 dummy, the following apply:

- (a) The value in relation to the BA plane is 550 mm; and
- (b) The value in relation to the DA plane is 840 mm; and
- (c) The rebound phase is not considered for the assessment of the plane DA.

Non-integral booster cushion: No part of the head of the dummy shall pass beyond the planes BA and DA as defined in Figure 1 below.

This shall be judged up to 300 ms or the moment that the dummy has come to a definitive standstill, whatever occurs first.

When testing using Q10 dummy the following apply:

- (a) The value in relation to the BA plane is 550 mm; and
- (b) The value in relation to the DA plane is 840 mm; and
- (c) The rebound phase is not considered for the assessment of the plane DA.

..."

Paragraph 6.4.4.1.1.1., figure 1, renumber as figure 4

Paragraph 6.4.4.1.2.1., figure 2, renumber as figure 5

Paragraph 7.1.3., amend to read:

"7.1.3. Dynamic testing for frontal, rear and lateral impact:

- (a) Frontal impact test shall be performed on:
 - (i) i-Size Enhanced Child Restraint Systems;
 - (ii) Specific vehicle ISOFIX Enhanced Child Restraint Systems;
 - (iii) i-Size booster seats Enhanced Child Restraint Systems;
 - (iv) Specific vehicle booster seats Enhanced Child Restraint Systems;
 - (v) Universal Belted Enhanced Child Restraint Systems;
 - (vi) Specific vehicle Belted Enhanced Child Restraint Systems;
 - (vii) Universal booster cushions Enhanced Child Restraint Systems;
 - (viii) Specific vehicle booster cushions Enhanced Child Restraint Systems;

..."

Paragraph 7.1.3.5.2.2., the reference to figure 1 and figure 1, renumber as figure 6 and amend to read:

"7.1.3.5.2.2. Installation of a non-integral Enhanced Child Restraint Systems on the test bench.

The unoccupied non-integral Enhanced Child Restraint System shall be placed on the test bench.

...

Figure 6
Load cell positions

...

Fit load cell 1 to the outboard position as shown Figure 6 ..."

Insert a new paragraph 7.1.3.7., to read:

"7.1.3.7. Restraint of booster cushions

Place a cotton cloth on the seating surface of the test bench. Position the booster cushion on the test bench, position the lower torso body block as described in Annex 26, Figure 1, on the seating surface, fit and apply the 3-point adult safety-belt and tension as prescribed in paragraph 7.1.3.5.2.2. With a strip of 25 mm-wide webbing or similar, tied around the booster, apply a load of 250 ± 5 N in the direction of arrow A (see Annex 26, Figure 2), in line with the seating surface of the test bench.

The booster cushion shall not be pulled completely out of the 3-point adult safety-belt and shall remain under the body block during the test."

Paragraph 7.2.4.3.4., the reference to footnote ⁴ and footnote ⁴, renumber as footnote ⁵

Paragraph 7.2.8.5., figure 3, renumber as figure 7

Paragraph 7.2.9.1., the reference to figure 4 and figure 4, renumber as figure 8

Paragraph 8.1, amend to read:

"8.1. The test report...

- (j) Adult safety-belt bench installation forces.
- (k) The minimum and maximum approved stature range for all categories of ECRS;
- (l) The internal dimensions according to Annex 18, for all categories of ECRS;
- (m) For booster cushions the minimum stature with corresponding sitting height according to paragraph 6.1.3.6."

Insert new paragraph 14.2.3., to read:

"14.2.3. For Universal booster cushion category Enhanced Child Restraint Systems, the following label shall be clearly visible on the exterior of the packing:

Notice

This is a Universal booster cushion Enhanced Child Restraint System. It is approved according to UN Regulation No.129, for use in i-Size compatible and universal vehicle seating positions as indicated by vehicle manufacturer in the vehicle user's manual.

If in doubt, consult the Enhanced Child Restraint System manufacturer or the retailer.

"

Paragraphs 14.2.3. to 14.2.10. (former), renumber as paragraphs 14.2.4. to 14.2.11.

Annex 2, amend to read:

"Annex 2

1. Arrangements of the approval mark

....

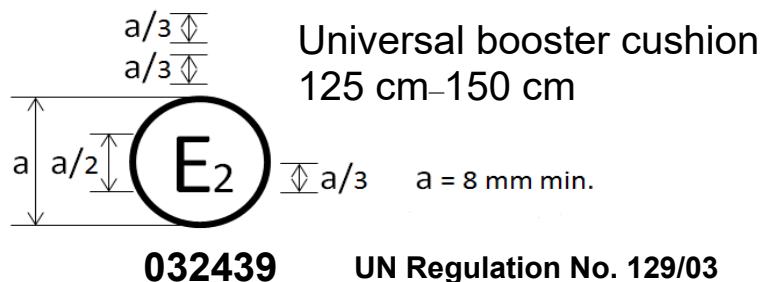

The Enhanced Child Restraint System bearing the above approval mark can be fitted in any i-Size seating position and Universal seating position, and used for the 125 cm–150 cm size range; it is approved in France (E 2) under the number 032439. The approval number indicates that the approval was granted in accordance with the requirements of the Regulation concerning the approval of Enhanced Child Restraint Systems used on-board of motor vehicles as amended by the 03 series of amendments. In addition, the name of the Regulation is to be identified on the approval mark followed by the series of amendment according to which the approval has been granted.

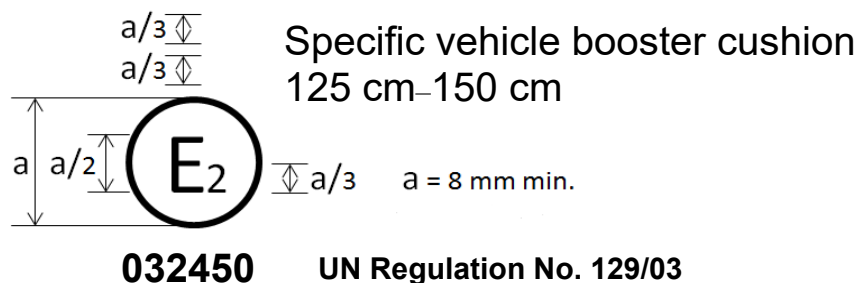

The Enhanced Child Restraint System bearing the above approval mark is a device not capable of being fitted in every vehicle but is capable of being used for the 125 cm–150 cm size range; it is approved in France (E 2) under the number 032450. The approval number indicates that the approval was granted in accordance with the requirements of the Regulation concerning the approval of specific vehicle booster cushion Enhanced Child Restraint Systems used on-board of motor vehicles as amended by the 03 series of amendments. In addition, the name of the Regulation needs to be identified on the approval mark followed by the series of amendment according to which the approval has been granted.

In case the Enhanced Child Restraint System is equipped with a module, the size range and the mass limit shall be on the module mark.

...."

Annex 20, amend to read:

"Annex 20

Minimum list of documents required for approval

	<i>i-Size or i-Size booster seat or Universal Belted or Universal booster cushion Enhanced Child Restraint System</i>	<i>Specific vehicle ISOFIX or booster seat or Belted or booster cushion Enhanced Child Restraint System</i>	<i>Paragraph</i>
General documents	Application letter/request	Application letter/request	3.1.
...
.....		List of vehicle model(s) – if applicable	Annex 1

"

Insert new Annex 25, to read:

"Annex 25

Device to measure the booster cushion height

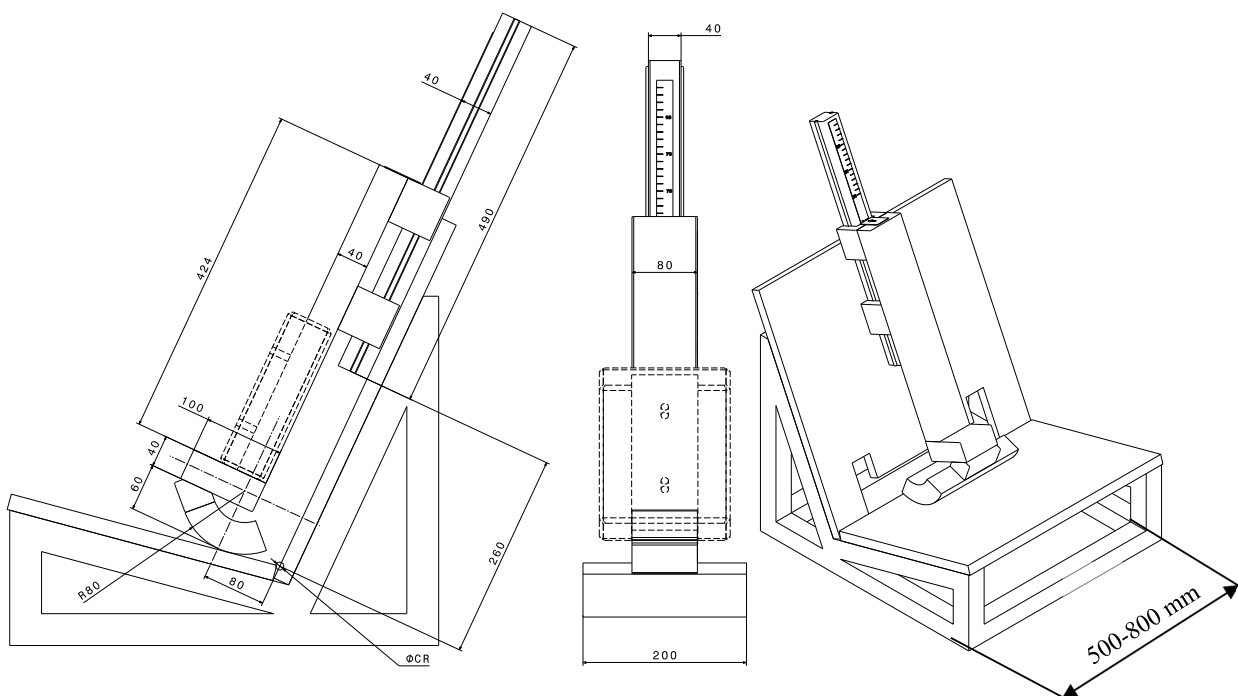

The mass of the device shall be 15kg +/-1kg

[all dimensions in mm]

Calibration of the measurement scale

To calibrate the ruler of the measurement device, its structure shall contact the supporting surface (Detail A). In this configuration, the scale shall show the calibration value of 78.7 cm (Detail B).

The calibration of the ruler is based on the sitting height of the Hybrid III 5th percentile dummy seated on the test bench defined in Annex 6 of this Regulation. When this dummy is seated on the test bench, the top of the head is 77.0 cm from the Cr axis. The nominal sitting height of the dummy is 78.7 cm. Therefore, 78.7 cm is used as the calibration value.

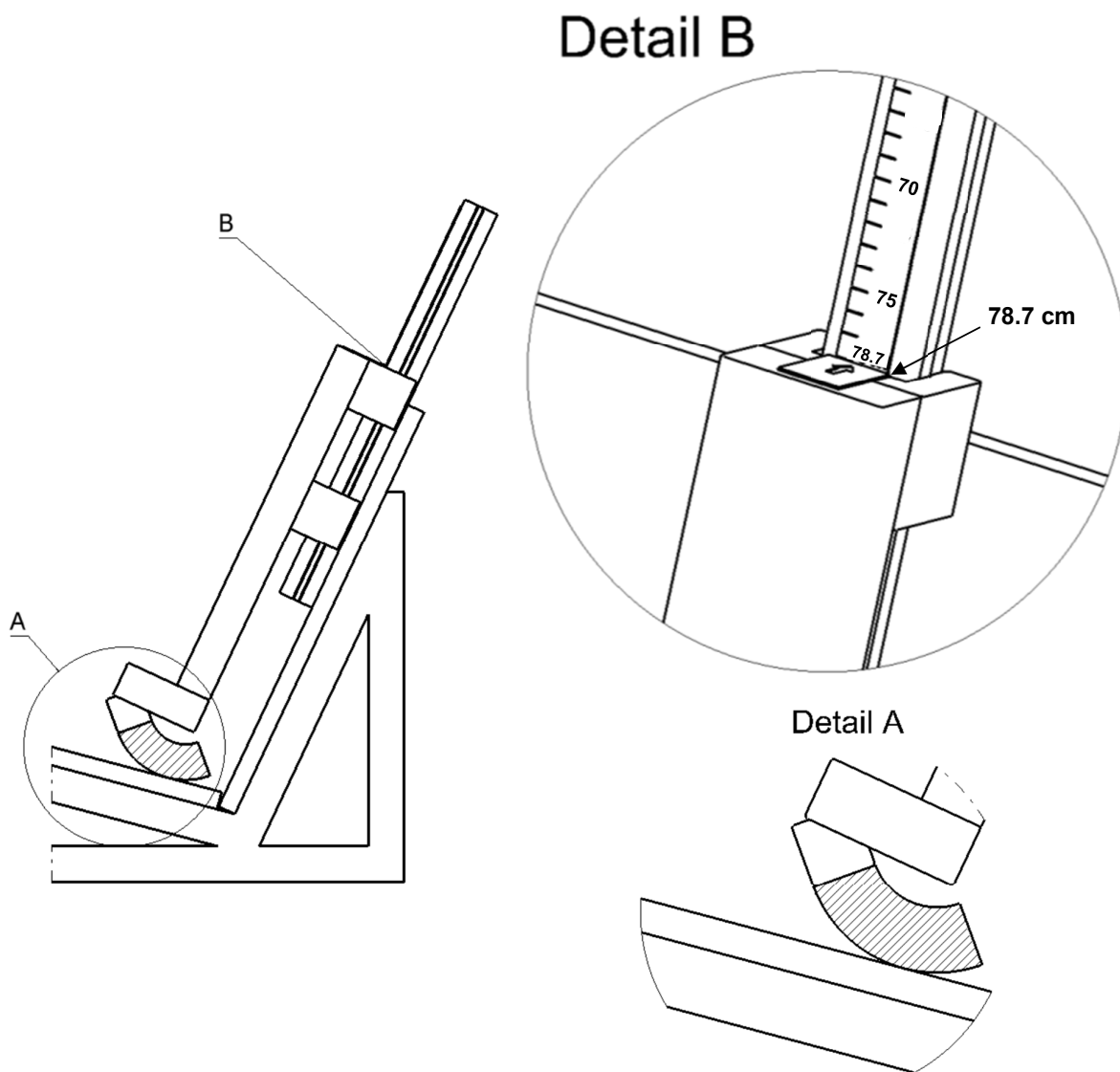

Insert new Annex 26, to read:

"Annex 26

Lower torso body block test

Figure 1
Manikin block (based on truncated P10)
Material: Expanded polystyrene (EPS) (40 to 45 g/l) or alternative non-deformable material

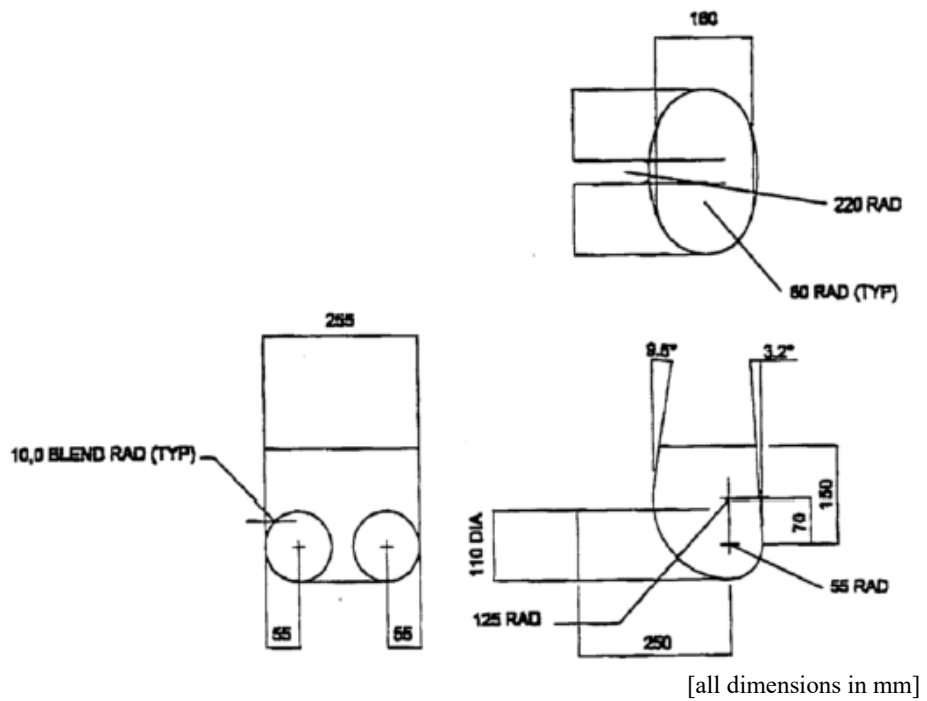
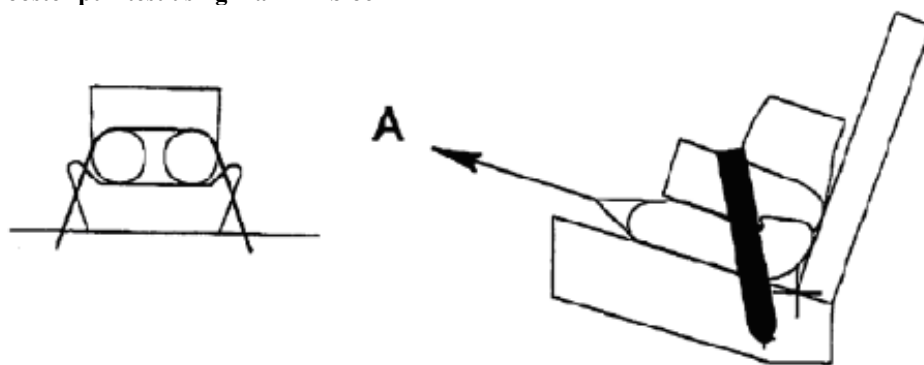

Figure 2
Booster pull test using manikin block



... "