

## **Proposal for the 04 series of amendments to UN Regulation No. 129**

### **Submitted by the expert from the European Association of Automotive Suppliers**

The text reproduced below was prepared by the expert from the European Association of Automotive Suppliers (CLEPA) to include corrections related to CLEPA formal document ECE/TRANS/WP.29/GRSP/2018/29 that defines the introduction of booster cushions into Regulation R129. The modifications to the formal document are marked in bold for new or strikethrough for deleted characters.

### **I. Proposal**

*Paragraph 3.2.2., amend to read:*

"3.2.2. The applicant shall indicate the kind of application:

...

- (j) Any combination of (c), (d), (e), (f), (g) and (h) as long as they fulfil paragraphs 5.4.2.2., 6.1.2. and 6.1.3. provided there is only one belt route and that the booster seat **and/or booster cushion** is not equipped with ISOFIX connectors."

*Paragraph 6.1.3.6., amend to read:*

"6.1.3.6 For booster cushions, ....

*Delete Figure 2*

*Insert new Figure 2*

**Figure 2**  
**Ruler of measurement device:**

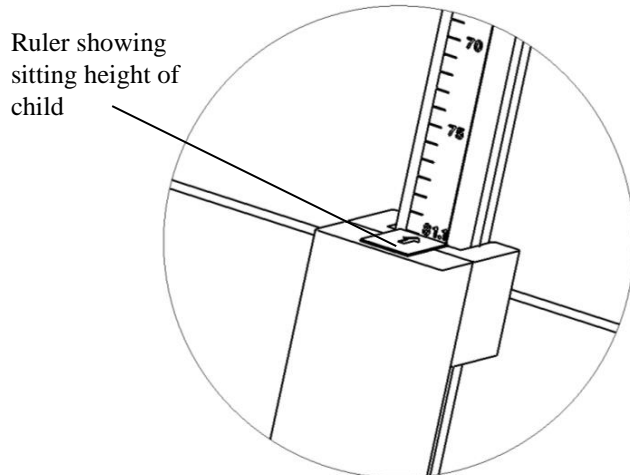

*Paragraph 6.1.3.6. Amend to read:*

- (a) The measured distance between the two points M and N represents the sitting height of a child who will use the cushion represented in Figure 1. The corresponding value is displayed by a ruler that is provided with the device as shown in Figure 12.
- (b) ...

*Paragraph 14.2.2., shall be deleted*

*Paragraph 16.11. amend to read:*

**“16.11. Notwithstanding paragraphs 16.9 and 16.10, Contracting Parties applying the UN Regulation shall continue to accept, and grant extensions to, UN type-approvals issued according to the preceding series of amendments to the UN Regulation, for the Enhanced Child Restraint Systems which are not affected by the changes introduced by the 03 series of amendments”**

*Insert new paragraphs 16.12. to 16.17., to read:*

- “16.12. Until 1 September 2024, Contracting Parties applying this UN Regulation shall continue to grant extensions of approvals to the 02 series of amendments to this UN Regulation.**
- 16.13. Until [1 September 2025], Contracting Parties applying this UN Regulation shall continue to grant extensions of approvals to the 03 series of amendments to this UN Regulation.**
- 16.14. As from the official date of entry into force of the 04 series of amendments, no Contracting Party applying this Regulation shall refuse to grant or refuse to accept UN type-approvals under this Regulation as amended by the 04 series of amendments.**

- 16.15. As from [1 September 2021], Contracting Parties applying this Regulation shall not be obliged to accept UN type-approvals to the preceding series of amendments, first issued after [1 September 2021].
- 16.16. As from [1 September 2023], Contracting Parties applying this Regulation shall not be obliged to accept type-approvals issued to the preceding series of amendments to this Regulation.
- 16.17. Notwithstanding paragraphs 16.14 and 16.15, Contracting Parties applying the UN Regulation shall continue to accept, and grant extensions to, UN type approvals issued according to the preceding series of amendments to the UN Regulation, for the Enhanced Child Restraint Systems which are not affected by the changes introduced by the 04 series of amendments."

Annex 2, amend to read:

## "Annex 2

### 1. Arrangements of the approval mark

... according to which the approval has been granted.

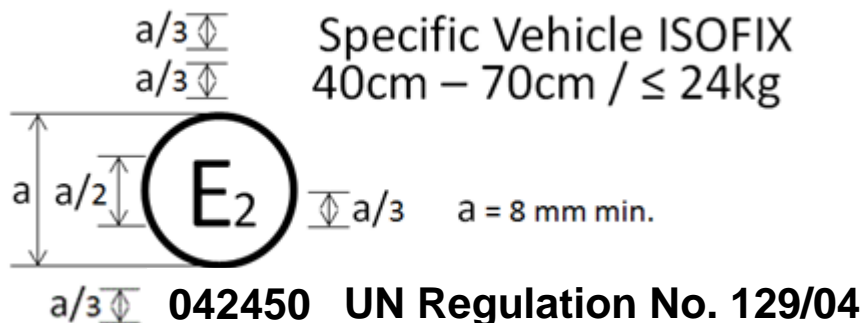
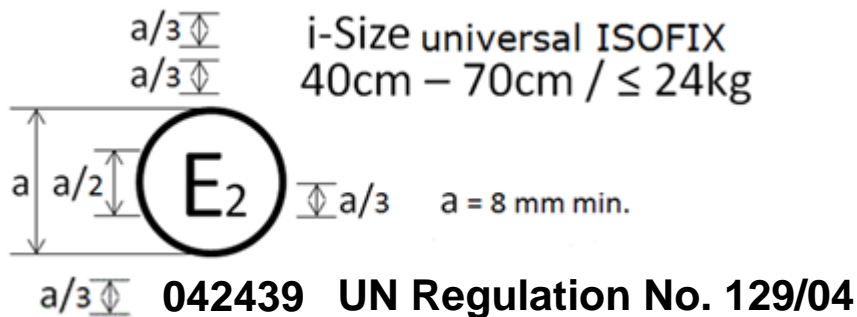

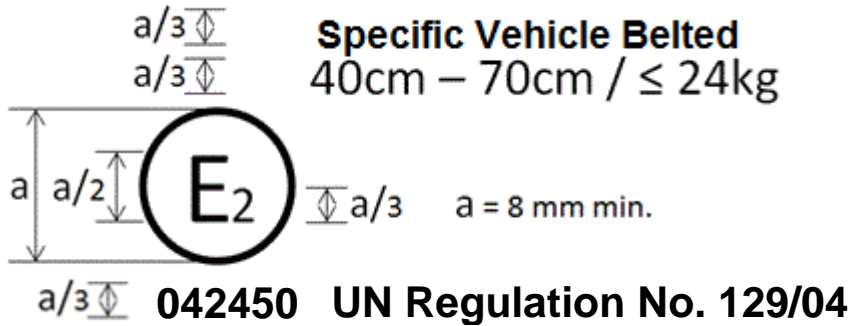
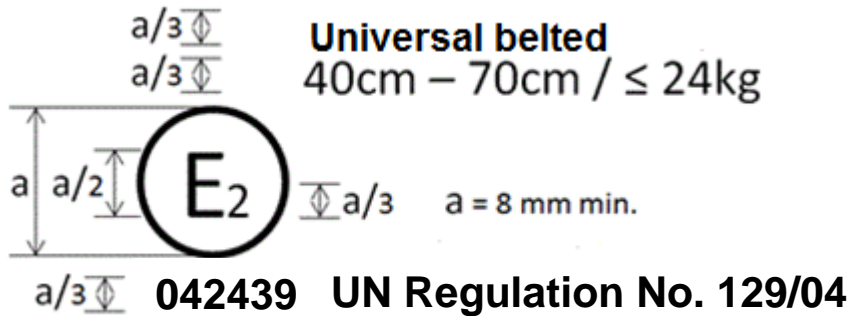

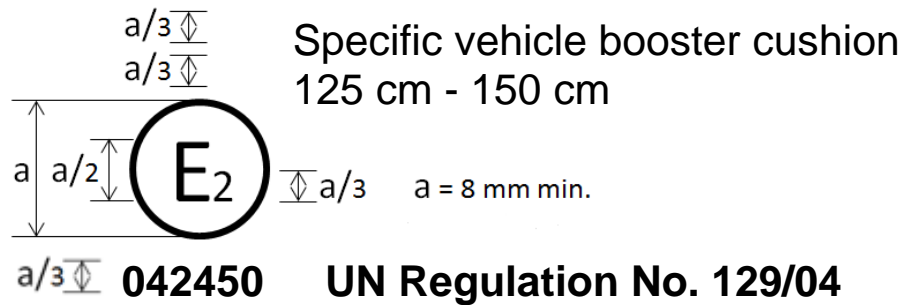
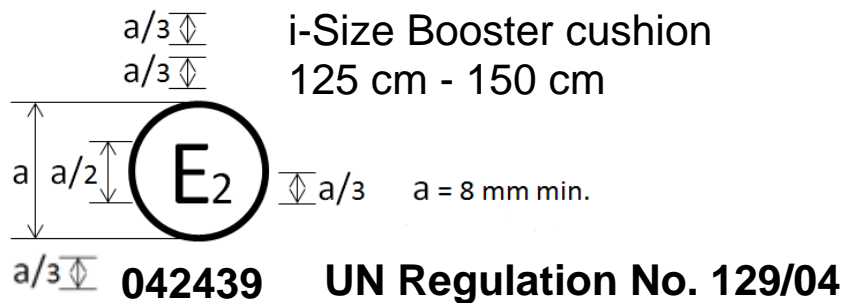

2. Arrangements of the approval mark in combination with a module mark

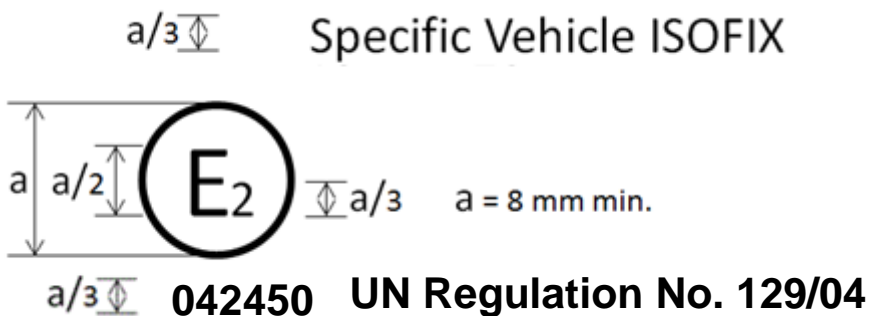
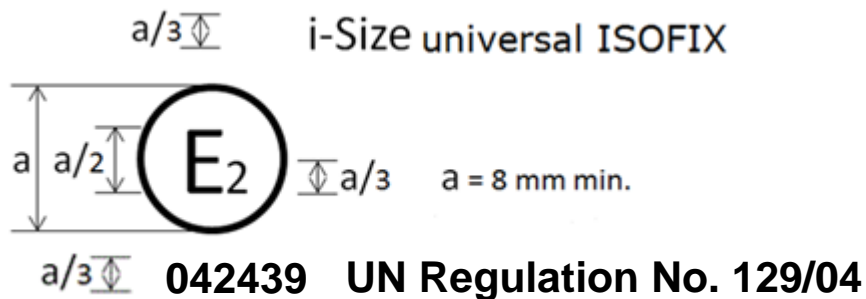

..."

Annex 6 – Appendix 3,

Figures 2b amend to read:

.....

“Figure 2B

Door panel geometry for testing non-integral ECRS **and integral belted ECRS** – side view  
(tolerance general:  $\pm 2$  mm and  $\pm 1$  degree)”

.....

Annex 25, amend to read:

## "Annex 25

### Measurement device for booster cushion height check

Delete Figure

Insert new Figure:

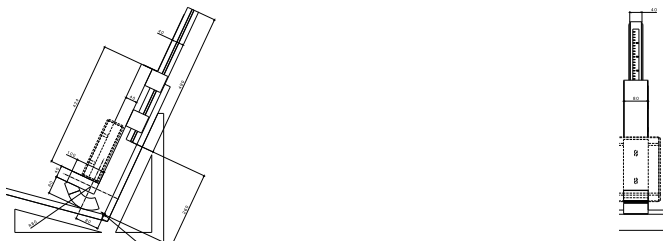

**The mass of the device shall be 15kg +/-1kg**

---

Delete Figure

Insert new Figure:

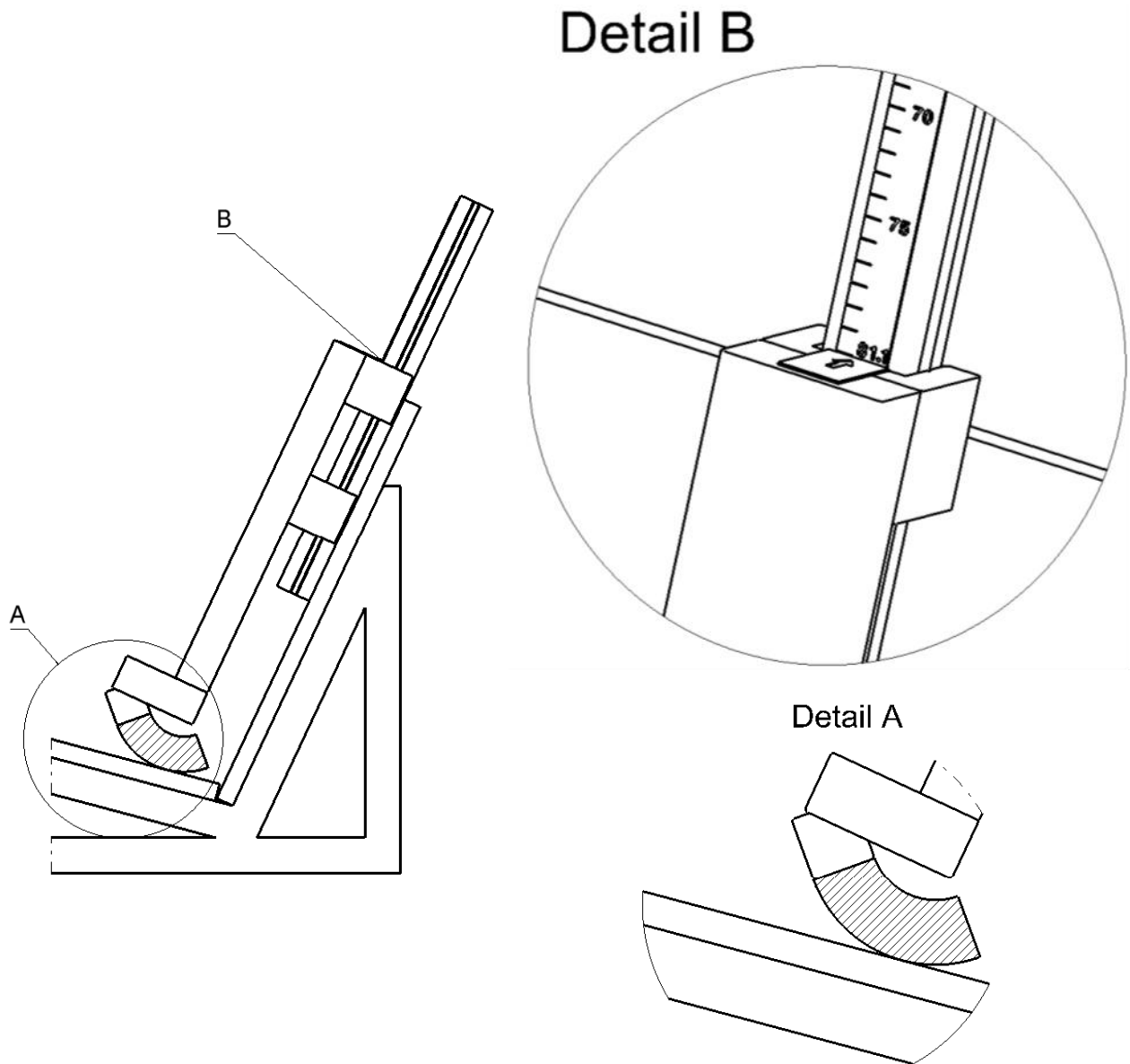

## **II. Justification**

1. The reference figure of the measurement device has been updated.
  2. Transitional provisions added
  3. The approval mark details have been updated for all categories to include all required information.
  4. The detailed drawings of the device have been updated.
-