

**Economic and Social Council**Distr.: General
24 November 2017

English only

Economic Commission for Europe**Inland Transport Committee****World Forum for Harmonization of Vehicle Regulations****Working Party on Passive Safety****Sixty-second session**

Geneva, 12–15 December 2017

Item 17 of the provisional agenda

UN Regulation No. 129 (Lateral collision)**Proposal for the 03 series of amendments (Phase 3) to UN Regulation No. 129 (Enhanced Child Restraint Systems)****Submitted by the expert from France***

The text reproduced below was prepared by the expert from France. It introduces the 03 series of amendments to UN Regulation No. 129 (Enhanced Child Restraint Systems (ECRS)) that were agreed upon by the experts of the Informal Working Group on Child Restraint Systems (IWG CRS) up to the last two meetings of the group. The modifications to the existing text of the UN Regulation No. 129, including ECE/TRANS/WP.29/2017/126 (Proposal for supplement 2 to the 02 series of amendments), are marked in bold for new or strikethrough for deleted characters.

* In accordance with the programme of work of the Inland Transport Committee for 2016–2017 (ECE/TRANS/254, para. 159 and ECE/TRANS/2016/28/Add.1, cluster 3.1), the World Forum will develop, harmonize and update Regulations in order to enhance the performance of vehicles. The present document is submitted in conformity with that mandate.

GE.17-20848(E)



* 1 7 2 0 8 4 8 *

Please recycle The recycling symbol, consisting of three chasing arrows forming a triangle.



I. Proposal

Paragraph 1., amend to read:

"1. Scope

This UN Regulation applies (in Phases 1, ~~and 2~~ **and 3**) to the following child restraint system for child occupants of power driven vehicles:

- (a) Integral Universal ISOFIX Enhanced Child Restraint Systems (i-Size);
- (b) Integral Specific vehicle ISOFIX Enhanced Child Restraint Systems;
- (c) ~~Non-integral~~ Universal Enhanced Child Restraint Systems (i-Size booster seat);
- (d) ~~Non-integral~~ ~~Specific~~ vehicle ~~Enhanced~~ ~~Child~~ ~~Restraint~~ ~~Systems~~ (~~Specific~~ vehicle booster seat);
- (e) **Integral Universal Belted Enhanced Child Restraint Systems;**
- (f) **Integral Specific vehicle Belted Enhanced Child Restraint Systems."**

Insert new paragraph 2.3.2., to read:

"2.3.2. "Universal Belted" (Integral Universal Belted Enhanced Child Restraint System) is a category of Enhanced Child Restraint System primarily designed to be attached only by the adult safety-belt in all Universal seating positions of a vehicle, as defined and approved according to UN Regulation No. 16."

Paragraph 2.3.2. (*former*), renumber as paragraph 2.3.3.

Insert new paragraph 2.7.3., to read:

"2.7.3. "Specific vehicle Belted" is a category of Integral Enhanced Child Restraint System connected to specific vehicle types. All vehicle anchorages are to be approved according to UN Regulation No. 14 or [XX]. Additional attachment points required for securing rearward facing Enhanced Child Restraint System shall be checked according to Annex 25. It is also an indication for Enhanced Child Restraint Systems that include the dashboard as a vehicle contact zone."

Paragraph 2.12., amend to read:

"2.12. "Anti-rotation device"

Means a device intended to limit the rotation of the Enhanced Child Restraint System during a vehicle impact and consisting of:

- (a) A top-tether strap; or
- (b) A support-leg.

Meeting the requirements of this UN Regulation and fitted to an ISOFIX anchorage system and ISOFIX top tether anchorages or vehicle floor contact surface meeting the requirements of UN Regulation No. 14 or UN Regulation No. XX.

An "Anti-rotation device" for a "specific vehicle ISOFIX" Enhanced Child Restraint System may comprise a top tether, a support-leg or, ~~any other means capable of limiting the rotation~~ **only for Rearward facing Enhanced Child Restraint System, a dashboard.**"

Paragraph 2.17.1., amend to read:

"2.17.1. "ISOFIX Vehicle seat fixture" means a fixture, according to ISOFIX size envelopes whose dimensions are given in Figures 1 to 7 of Appendix 2 to Annex 17 to UN Regulation No. 16, used by an Enhanced Child Restraint System manufacturer to determine the appropriate dimensions of **an Integral Universal Belted Enhanced Child Restraint System or an ISOFIX Enhanced Child Restraint System and including** the location of its ISOFIX attachments."

Paragraph 2.26., amend to read :

"2.26. "Infant carrier" means **an Integral Enhanced Child Restraint System that restrains a child up to 15 months old and up to 83 cm stature** intended to accommodate the child in a rearward-facing semi-recumbent position. It is so designed as to distribute the restraining forces over the child's head and body excluding its limbs in the event of the frontal collision. **It is designed to be removed from the vehicle with the child inside and without opening any harness, and to be carried it outside of the vehicle.**"

Insert new paragraph 2.51.3., to read:

"2.51.3. "Universal seating position" means a location in accordance with **paragraph 8.2.2.5.2.(b) of UN Regulation No. 16.**"

Paragraphs 2.56.1. and 2.56.2., amend to read:

"2.56.1. "Class A device" prevents the child from pulling the webbing of the retractor through to the lap part of the belt, when the adult belt is used to restrain the child directly (**Non-Integral Enhanced Child Restraint System**).

2.56.2. "Class B device" (~~to be used in phase III~~) allows the retention of an applied tension in the lap part of an adult safety-belt, when the adult belt is used to restrain ~~the~~ **Integral Enhanced Child Restraint System**. The device intends to prevent the webbing from slipping from the retractor through the device, which would release the tension and place the restraint in a non-optimal position."

Paragraph 2.57., amend to read:

"2.57. "Module", is a part of an **Enhanced Child Restraint System** that is separate from the ISOFIX attachments and **hosts and restrains the child, in direct contact with the child**. A module can be used **in combination with one or more a base whether or, not if allowed in this UN Regulation**, as a stand-alone **Integral Universal Belted** to restrain a child in a **vehicle** ~~A base is allowed to accept more than one module (Module A, Module B, etc.)~~."

Insert new paragraph 2.58., to read:

"2.58. "Base", is a part of an **Enhanced Child Restraint System** that forms an **interface between the vehicle and the module of an Enhanced Child Restraint System and has no direct contact with the child**. A base is connected to the vehicle using **ISOFIX anchorages or a vehicle safety-belt and an anti-rotation device if applicable**.

A base is allowed to accept more than one module (Module A can be replaced by Module B, etc.)."

Insert new paragraph 2.59., to read:

- "2.59. **"Built in", is an Enhanced Child Restraint System made as an integral part or incorporated as an add-on part of a vehicle. The vehicle manufacturer shall be the applicant for approval."**

Insert new paragraphs 2.60. and 2.61., to read:

- "2.60. **"Belt route", means the trajectory of the adult safety-belt to be used to fasten the ECRS (integral ECRS) or to restrain the child (non integral ECRS). Trajectories for symmetrical installation of the ECRS are considered as a single belt route.**
- 2.61. **"Webbing path", means the defined points on the ECRS where the webbing of the adult safety-belt must to pass to conform the belt route as specified by the ECRS manufacturer."**

Paragraph 3.2.2., amend to read:

- "3.2.2. The applicant shall indicate the kind of application:
- (a) Application for an i-Size Enhanced Child Restraint Systems; or
 - (b) Application for a specific vehicle ISOFIX **Enhanced Child Restraint System**; or
 - (c) Application for a i-Size booster seat Enhanced Child Restraint System; or
 - (d) Application for a specific vehicle booster seat Enhanced Child Restraint System; **or**
 - (e) **Application for a Universal Belted Enhanced Child Restraint Systems; or**
 - (f) **Application for Specific vehicle Belted Enhanced Child Restraint Systems; or**
 - (g) Or any combination of (a),(b),(c) and (d) as long as they fulfil paragraph 5.4.2.2., **6.1.2.** and ~~6.1.3.3.~~ **provided there is only one belt route or"**
 - (h) **Any combination of (c), (d), (e), (f), as long as they fulfil paragraphs 5.4.2.2., 6.1.2. and 6.1.3.~~3.~~, provided there is only one belt route and that the booster seat is not equipped with ISOFIX connectors."**

Paragraph 4.3., amend to read:

- "4.3. The following information shall be clearly indicated on the product:
- (a) The orientation of the Enhanced Child Restraint System relative to the vehicle;
 - (b) The size range(s) of the Enhanced Child Restraint System in centimetres;
 - (c) The maximum occupant mass allowed for the Integral Enhanced Child Restraint System in kilograms.

~~If the Enhanced Child Restraint System is to be used in combination with an adult safety belt, the correct webbing path shall be clearly indicated by means of a drawing permanently attached to the Enhanced Child Restraint System. If the restraint is held in place by the adult safety belt, the webbing paths shall be clearly marked on the product by colour coding. The colours used for the path of the safety belt when the device is installed in the forward-facing position shall be red and when installed in the rearward-facing shall be blue. The same colours shall also be used on the labels on the device that illustrate the methods of use.~~

~~There shall be a clear differentiation between the intended paths for the lap section and the diagonal section of the safety belt. Indication such as colour coding, words, shapes, etc. shall distinguish between sections of the safety belt.~~

~~The marking defined in this paragraph shall be visible with the Enhanced Child Restraint System in the vehicle, with the child in the Enhanced Child Restraint System."~~

Insert new paragraphs 4.6. to 4.6.3., to read:

"4.6. Webbing path.

The markings defined in this paragraph shall be permanently and durably attached and visible on the Enhanced Child Restraint System installed in the vehicle, and with the child seated in the Restraint System. The markings shall be placed on both sides of the Enhanced Child Restraint System. The vehicle seat illustrated on the marking shall face the same direction as the actual vehicle seat.

There shall be a clear differentiation between the intended paths for the lap section and the diagonal section of the safety-belt. Indication such as colour coding, words, shapes, etc. shall distinguish between sections of the adult safety-belt.

4.6.1. The adult safety-belt route markings shall be placed on all belt guides and lock off devices. The adult safety-belt route markings shall be at least the width of the adult webbing path.

4.6.2. For Non-Integral Enhanced Child Restraint System to be used in combination with an adult safety-belt to restrain the child, the correct webbing path according to paragraph 6.1.3.4. shall be clearly marked on the product. This shall be by means of an installation drawing on a label permanently attached to the Enhanced Child Restraint System that shows the correct path across the child's body. The colour used for the adult belt route marking of the safety-belt when the device is installed shall be green. The same colour shall also be used for the webbing path on the labels on the device that illustrate the installation.

4.6.3. For Integral Belted Enhanced Child Restraint System held in place by the adult safety-belt, the webbing paths according to paragraph 6.1.2.5. shall be clearly marked on the product, and indicated by means of a drawing permanently attached to the Enhanced Child Restraint System. The colour used for the path of the adult belt route marking, when the device is installed in the forward-facing or rearward-facing positions shall be green same colour shall also be used on the labels on the device that illustrate the installation."

Paragraphs 4.6. to 4.7.2.(former), renumber as paragraphs 4.7. to 4.8.2.

Paragraph 4.7.3., shall be deleted

Insert new paragraphs 4.11. to 4.11.4., to read:

"4.11. Marking for Integral Belted Enhanced Child Restraint System.

The marking shall be located on the part of the Enhanced Child Restraint System which includes the main load-bearing contact points.

One of the following information labels shall be permanently visible to the person installing the Enhanced Child Restraint System in a vehicle:

- 4.11.1. Universal Belted Enhanced Child Restraint Systems shall have a permanently attached label with the following information visible to the person installing the Enhanced Child Restraint System in the vehicle:**

Universal Belted 

- 4.11.2. Specific vehicle Belted Enhanced Child Restraint System (including built-in systems) shall have a permanently attached label with the following information visible to the person installing the Enhanced Child Restraint System in the vehicle:**

Specific vehicle Belted 

- 4.11.3. An international approval mark as defined in paragraph 5.4.1. In case the Enhanced Child Restraint System containing module(s) this marking shall be permanently attached to the part of the Enhanced Child Restraint System that includes the main load-bearing contact points.**
- 4.11.4. An international module mark as defined in paragraph 5.4.3. In case the Enhanced Child Restraint System containing module(s) this marking shall be permanently attached to the module part of the Enhanced Child Restraint System."**

Paragraph 4.8. (former), renumber as paragraph 4.12. and amend to read:

"4.12. Additional markings

...

- (g) **The shoulder belt part and the lap belt part of the adult safety-belt used for attaching the infant carrier shall be indicated with specific icons for the shoulder webbing path and lap belt webbing paths, visible for the user, close to the belt guiding area (icon A and B) or on the installation drawings (icon C). Icons A, B and C shall have the same colour coding (darker green on lap belt) as used on the installation drawings and the minimum size is 20 mm in diameter.**

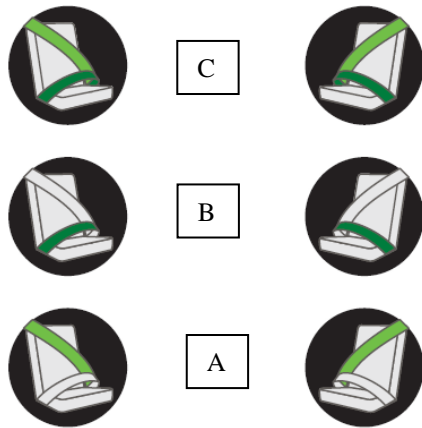

"

Paragraph 5.4.2.1., amend to read:

"5.4.2.1. The words "i-Size universal ISOFIX", or "i-Size booster seat", or "specific vehicle ISOFIX" or "specific vehicle booster seat" **or "Universal Belted", or "Specific vehicle Belted"**, depending on the category of Enhanced Child Restraint System;"

Paragraph 5.4.3.1., amend to read:

"5.4.3.1. The words "R129" followed by a dash and the same approval number as the part of the **Enhanced Child Restraint System** which includes the ISOFIX attachments **or main load bearing contact points**;"

Paragraph 6.1.2.2., Table 1 amend to read:

Table 1

Possible configurations for type approval for Integral Enhanced Child Restraint Systems

	Orientation	Category				
		i-Size ECRS	Integral Vehicle ECRS	Specific ISOFIX	Universal Belted	Specific vehicle Belted
INTEGRAL	Lateral facing (Carry-cot)	NA	A		NA	A
	Rearward facing	A	A		A	A
	Forward facing	A	A		A	A

Note:

ECRS: Enhanced Child Restraint System

A: Applicable

NA: Non-Applicable

Insert new paragraphs 6.1.2.3. to 6.1.2.6., to read:

"6.1.2.3. For the "Universal Belted" category, this shall be by means of the adult safety-belt [only].

- 6.1.2.4. For the "Specific vehicle Belted" category, this shall be [primarily] by means of the adult safety-belt.
- 6.1.2.5. Integral Enhanced Child Restraint Systems of the Belted categories shall have only one adult safety-belt route and a main load-bearing contact point, between the Enhanced Child Restraint System and the adult safety-belt on each side of the Enhanced Child Restraint System. This point shall not be less than 150 mm from the Cr axis when measured with the Enhanced Child Restraint System on the dynamic test bench installed in accordance with paragraph 7.1.3.5.2.3. of this UN Regulation, without a dummy. This shall apply to all adjustment set-ups and webbing paths.
- 6.1.2.6. The adult safety-belt required to secure a Belted Integral Enhanced Child Restraint System on the dynamic test bench is defined in Annex 23 to this UN Regulation. The Enhanced Child Restraint System shall be secured onto the test bench using the appropriate standard safety-belt described in Annex 23 using a preload tension of $50\text{N} \pm 5\text{N}$. The dummy shall not be installed unless the design of the restraint is such that the installation of a dummy would increase the length of belt used. With the Enhanced Child Restraint System in the installed position, there shall be no additional tension in the belt, apart from that exerted by the standard retractor ($4 \pm 3\text{ N}$), where fitted. Where the retractor belt is used, this condition shall be met with at least 150 mm of belt remaining on the spool.
- A clamping mechanism used according to paragraph 7.1.3.5.2.3. shall not influence the webbing path."**

Paragraph 6.1.2.3.(former), renumber as paragraph 6.1.2.7.

Paragraph 6.1.3.4., amend to read:

- "6.1.3.4. Enhanced Child Restraint Systems of the ~~i-Size~~ booster seat categories shall have **only one adult safety-belt route and** a main load-bearing contact point, between the Enhanced Child Restraint System and the adult safety-belt **on each side of the Enhanced Child Restraint System**. This point shall not be less than 150 mm from the Cr axis when measured with the Enhanced Child Restraint System on the dynamic test bench installed in accordance with paragraph 7.1.3.5.2.2. of this UN Regulation, without a dummy. This shall apply to all adjustment ~~configuration~~ **set-ups and webbing paths."**

Paragraph 6.2.1.3., amend to read:

- "6.2.1.3 If it is possible to change the inclination of the Enhanced Child Restraint System, this change in inclination shall not require manual readjustment of any other part of the Enhanced Child Restraint System. A deliberate hand-action shall be necessary in order to change the inclination of the Enhanced Child Restraint System.
- During the dynamic tests, the standard safety-belt used to install an integral belted Enhanced Child Restraint System shall not become disengaged from any guide or locking device utilized for the test conducted."**

Paragraph 6.2.1.5., amend to read:

- "6.2.1.5. All restraint ... excessive stresses.

~~Moreover, the design shall be such that compression loads shall not be imposed on the crown of the child's head in the event of a collision;~~

In the case of booster seats, the lap portion of the adult safety-belt shall be positively guided on both sides to ensure that the loads transmitted by the adult lap belt are transmitted through the pelvis. The positive guidance of loads over the pelvis shall be realised from the moment that the child is installed; the lap belt shall pass over the top of the thigh, just touching the fold with the pelvis. The angles α and β between the tangent line in which the belt touches the thighs and the horizontal shall be greater than 10° .

Figures of Strapped child

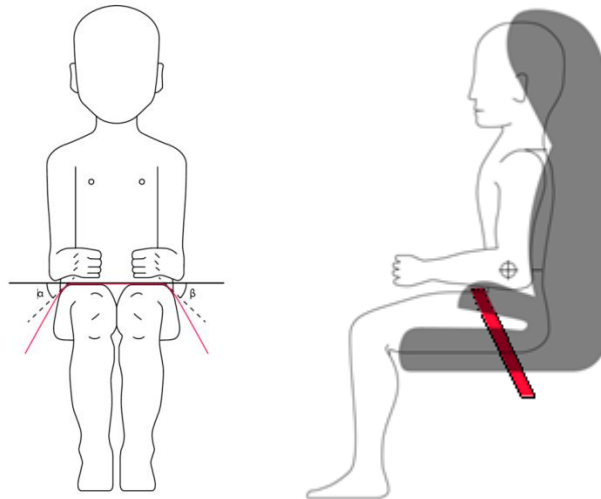

Paragraph 6.2.1.6., amend to read:

"6.2.1.6. For i-Size or specific...

During the dynamic tests, the standard safety-belt used to install a non-integral Enhanced Child Restraint System, shall not become disengaged from any guide or locking device utilized for the test conducted; however, for the shoulder portion of the standard safety-belt this shall be judged up to the moment that the maximum horizontal head excursion of the dummy is reached."

Paragraph 6.2.1.10., amend to read:

"6.2.1.10. At least the worst case ~~configuration~~ of the dynamic test for the Enhanced Child Restraint System shall be performed after conditioning according to paragraph 7.2.6."

Paragraph 6.2.3., amend to read:

"6.2.3. It shall not be possible to remove or detach without the use of specific tools, any components not designed to be removable or detachable **for maintenance or change of configuration purpose**. Any components that are designed to be removable **or detachable for maintenance or adjustment purpose** shall be so designed as to avoid any risk of incorrect assembly and use, as the assembly and disassembly processes shall be explained in detail in the restraint user guides. **For integral Enhanced Child Restraint Systems**

~~Any harness belt or impact shield shall be capable of its full range of adjustment without disassembly."~~

Paragraph 6.3.2.2.1., amend to read:

"6.3.2.2.1. Integral Class Enhanced Child Restraint Systems

The maximum external dimensions for the width, height and depth of the Enhanced Child Restraint System and **if fitted**, the locations of the ISOFIX anchorages system, with which its attachments shall engage, shall be defined by the ISOFIX Vehicle Seat Fixture as defined in paragraph 2.17.1. of this UN Regulation.

- (a) i-Size **or Universal Belted** Forward facing Enhanced Child Restraint Systems shall fit within the ISO/F2x size envelope for a reduced-height forward-facing toddler CRS;
- (b) i-Size **or Universal Belted** Rearward facing Enhanced Child Restraint Systems shall fit within the ISO/R2 size envelope for a reduced-size rearward-facing toddler CRS;
- (c) Specific vehicle ISOFIX **or Specific vehicle Belted** Enhanced Child Restraint Systems shall fit:
 - (i) in vehicle(s) specified in a list or
 - (ii) at least in one of the ISO (R1, R2X, R2, R3, F2X, F2, F3, L1, L2) size envelopes as described in Annex 17 Appendix 2 of UN Regulation No. 16.

When conducting this assessment, the Integral Enhanced Child Restraint System shall be adjusted to the largest size of its declared stature range (height, depth and width dimensions as defined in Annex 18). If the Enhanced Child Restraint System is capable of being adjusted to different positions of seat surface inclination, the fitting assessment shall be done in at least one position. If other positions of inclination are outside the limits of the applicable size envelope, the user manual shall indicate that the child restraint may not fit in all approved vehicles when used in one of these positions.

~~i-Size booster seats shall be adjusted to accommodate children of 135 cm stature (height, depth and width dimensions as defined in Annex 18) or to the largest size of its declared stature range in case the upper limit is below 135 cm. In this case, it must fit within each of its declared Vehicle Seat Fixtures in at least one adjustable position. The Enhanced Child Restraint System may be adjusted to other inclined positions (less or more reclined) that are outside the Vehicle Seat Fixture's height; in this case, the child restraint manufacturer's user manual shall clearly indicate that when used in one of these configuration arrangements, the Enhanced Child Restraint System may not fit in all vehicles approved for a Universal fixture."~~

Paragraph 6.3.2.2.2., amend to read:

"6.3.2.2.2. Non-Integral Class Enhanced Child Restraint Systems

The maximum external dimensions for the width, height and depth of the Enhanced Child Restraint System and the locations of the ISOFIX anchorages system if any, with which its attachments shall engage, shall be defined by the i-Size booster seat fixture as defined in paragraph 2.17.2. of this UN Regulation.

- (a) i-Size booster seat Enhanced Child Restraint Systems shall fit within the ISO/B2 size envelope;
- (b) Specific vehicle booster seat Enhanced Child Restraint Systems shall fit:
 - (i) in vehicle(s) specified in a list; or
 - (ii) at least in one of ISO/B2 –ISO/B3 size envelope as described in Annex 17, Appendix 2 of UN Regulation No. 16.

When conducting this assessment, the non-integral Enhanced Child Restraint System shall be adjusted to accommodate children of 135 cm stature (height, depth and width dimensions as defined in Annex 18) or to the largest size of its declared stature range if the upper limit is below 135 cm.

~~If the Non-integral Enhanced Child Restraint System is capable of being adjusted to different positions of seat surface inclination, the fitting assessment shall be done in at least one position.~~

The Non-integral Enhanced Child Restraint System shall fit within the booster seat fixture in all angles of inclination of the fixture (90°-110°). The Enhanced Child Restraint System may be adjusted between inclination angles or positions to fit within the different booster seat fixture angles.

If other positions of inclination are outside the limits of the applicable size envelope, the user manual shall indicate that the child restraint may not fit in all approved vehicles when used in one of these positions. If the Non-integral Enhanced Child Restraint System has a declared stature range above 135 cm, and if it is necessary to adjust the child restraint outside the limits of the applicable size envelope for such adjustments (height, depth and width dimensions), the user manual shall indicate that the child restraint may not fit in all approved vehicles when used in one of these positions.

Paragraph 6.6.4.1.2., amend to read:

"6.6.4.1.2. Enhanced Child Restraint Systems of the specific vehicle categories shall be assessed for fit with each vehicle model for which the Enhanced Child Restraint System is intended. The Technical Service responsible for conducting the test may reduce the number of vehicle configurations **arrangements** tested if they do not differ greatly in the aspects listed in paragraph 6.6.4.1.2.3. of this UN Regulation. This Enhanced Child Restraint System shall be dynamically tested in one of the following ways: ..."

Paragraph 6.6.4.3.1., Table 5 amend to read:

"...

Abdominal pressure****	P	Bar	NA	NA	1.2	1.0	1.0	1.2
------------------------	---	-----	----	----	-----	-----	-----	-----

* HPC: see Annex 17.

** To be reviewed within 3 years following entry into force of the series 01 of this UN Regulation.

*** Cum 3ms means cumulative 3ms value.

**** **Abdominal pressure, the highest recorded value is applicable for injury assessment (i.e., when the right handed sensors record 1.3 bar and the left handed sensor 1.0 bar, the recorded 1.3 bar is to be used for injury assessment).**"

Paragraph 6.6.4.4.1.1., amend to read:

"6.6.4.4.1.1.1. Where a test is conducted in accordance with paragraphs 6.6.4.1.6.21.1, 6.6.4.1.6.1.2. or paragraph 6.6.4.1.8.2. above, a tolerance of +10 per cent shall be applicable to the head excursion value distance between Cr point and plane AB."

Paragraph 6.6.4.4.1.2.1., amend to read:

"6.6.4.4.1.2.1. Head excursion: no part of the head of the dummy shall pass beyond the planes FD, FG and DE, as shown in figure 2 below. This shall be judged up to 300 ms or the moment that the dummy has come to a definitive standstill whatever occurs first.

Except when testing using Q6 or Q3 dummy where the value in relation to the FD plane is 840 mm

Where a test is conducted with paragraphs 6.6.4.1.6.[21.1. or paragraph 6.6.4.1.6.1.2.] or paragraph 6.6.4.1.8.2. above, only the second configuration test results without 100 mm diameter bar will be considered.

Figure 2

Arrangement for testing a rearward-facing device, not supported by the dashboard

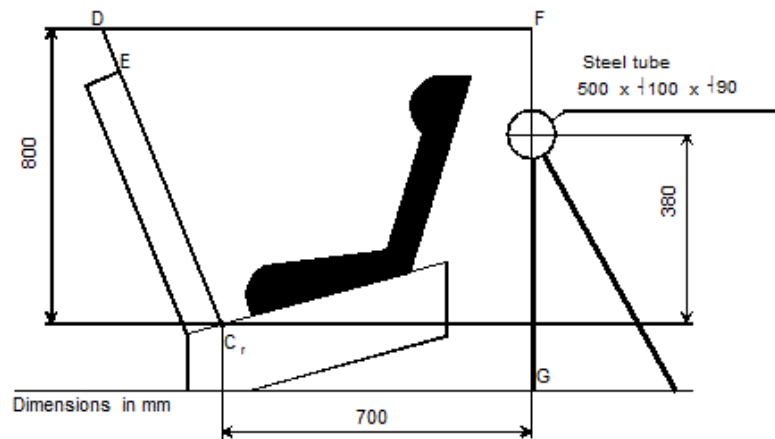

"

Insert new paragraphs 6.7.6. to 6.7.6.5., to read:

6.7.6. Lock-off device

6.7.6.1. The lock-off device shall be permanently attached to the Enhanced Child Restraint System.

6.7.6.2. The lock-off device shall not impair the durability of the adult belt and shall undergo the temperature test operation requirements given in paragraph 7.2.7.1.

6.7.6.3. The lock-off device shall not prevent the rapid release of the child.

6.7.6.4. Class A device

The amount of slip of the webbing shall not exceed 25 mm after the test prescribed in paragraph 7.2.9.1. below.

6.7.6.5. Class B device

The amount of slip of the webbing shall not exceed 25 mm after the test prescribed in paragraph 7.2.9.2. below."

Paragraph 7.1.2.7., amend to read:

"7.1.2.7. These tests shall be carried out using both the smallest and the largest appropriate dummy of the size range for which the restraining device is intended. Any adjustment of the dummy or Enhanced ~~child-Child restraint-Restraint systems-Systems~~ during the complete test cycle is not allowed."

Paragraph 7.1.3., amend to read:

"7.1.3. ...
 (e) The lateral dynamic test(s) will be performed in this(ese) ~~configuration~~
arrangement(s);
 ..."

Insert new paragraph 7.1.3.5.2.3., to read:

"7.1.3.5.2.3. Installation of an Integral Enhanced Child Restraint Systems "Universal Belted " seat or Specific vehicle Belted seat on the test bench.

The unoccupied belted Enhanced Child Restraint System shall be placed on the test bench.

Fit load cell 1 to the outboard position as shown Figure 1. Install the Enhanced Child Restraint System in the correct position. If a lock-off device is fitted to the Enhanced Child Restraint System and acts upon the diagonal belt, place load cell 2 at a convenient position behind the Enhanced Child Restraint System between the lock-off device and the buckle as shown above. If no lock-off device is fitted or if the lock-off device is fitted at the buckle, position the load cell at a convenient position between the pillar loop and the Enhanced Child Restraint System.

Adjust the lap portion of the reference belt to achieve a tension load of $50 \text{ N} \pm 5 \text{ N}$ at load cell 1. Make a chalk mark on the webbing where it passes through the simulated buckle.

While maintaining the belt at this position, adjust the diagonal to achieve a tension of $50 \text{ N} \pm 5 \text{ N}$ at load cell 2 by either locking the webbing with the Enhanced Child Restraint System webbing locker or by pulling the belt between the belt clamping mechanism and the standard retractor. If the tension in load cell 2 is achieved by pulling the belt between the clamping mechanism and the retractor, the clamping mechanism shall now be locked.

Extract all webbing from the retractor spool and rewind the excess webbing keeping a tension of $4 \pm 3 \text{ N}$ in the belt between the retractor and the pillar loop. The spool shall be locked before the dynamic test.

The dummy shall be placed in the Enhanced Child Restraint System separate from the seat-back of the chair by a flexible spacer. The spacer shall be 2.5 cm thick and 6 cm wide. It shall have length equal to the shoulder height less the thigh height, both in the sitting position and relevant to the dummy size being tested. The resulting height of the spacer is listed in the table below for the different dummy sizes. The

board should follow as closely as possible the curvature of the seat and its lower end should be at the height of the dummy's hip joint.

	<i>Q0</i>	<i>Q1</i>	<i>Q1.5</i>	<i>Q3</i>	<i>Q6</i>	<i>Q10</i> (design targets)
<i>Dimensions in mm</i>						
Height of spacer device for positioning of dummy	173 ± 2	229 ± 2	237 ± 2	250 ± 2	270 ± 2	359 ± 2

Adjust the Enhanced Child Restraint System belt in accordance with the manufacturer's instructions, but to a tension of 250 ± 25 N above the force needed to overcome the friction between the webbing and the adjuster, with a deflection angle of the strap at the adjuster of $45 \pm 5^\circ$, or alternatively, the angle prescribed by the manufacturer.

The spacer shall then be removed and the dummy pushed towards to the seat back. Distribute the slack evenly throughout the harness."

Paragraph 7.1.3.5.2.3.(former), renumber as paragraph 7.1.3.5.2.4.

Paragraph 7.1.3.6.2., amend to read:

"7.1.3.6.2. If the ~~i-Size~~ Enhanced Child Restraint System uses a top tether, one test shall be carried out with the smallest dummy with the shorter distance of the top tether (anchorage point G1). A second test shall be carried out with the heavier dummy with the longer distance of the top tether (anchorage point G2). Adjust the top tether to achieve a tension load of 50 ± 5 N. For side lateral impact the ISOFIX Enhanced child restraint shall be tested with only the shorter distance of the top tether."

Paragraph 7.1.3.6.3., amend to read:

"7.1.3.6.3. If the ~~i-Size~~ Enhanced Child Restraint System uses a support-leg, as an anti-rotation device the hereafter mentioned dynamic tests shall be carried out as follows:

- (a) The tests for frontal impact shall be conducted with the support-leg adjusted to its maximum adjustment compatible with the positioning of the trolley floor pan. The tests for rear impact shall be conducted with the worst case position selected by the Technical Service. During the tests the support-leg shall be supported by the trolley floor pan as described in Annex 6, Appendix 2, figure 2;
- (b) In the case of support-legs out of the plane of symmetry, the worst case shall be selected by the Technical Service for the test;
- (c) In the case of "specific vehicle ISOFIX" category, the support-leg shall be adjusted as specified by the Enhanced Child Restraint System manufacturer;
- (d) The leg length of a support-leg shall be adjustable in such a way that it is able to cover the complete span of floor pan levels that are allowed for in UN Regulation No. 16, Annex 17 for car seats to be approved for the installation i-Size Enhanced Child Restraints Systems."

Paragraph 7.2.3.2., amend to read:

"7.2.3.2. The free end of the strap shall be arranged in the same ~~configuration way~~ as when the device is in use in the vehicle, and shall not be attached to any other part."

Paragraph 7.2.5.2.6.2., amend to read:

"7.2.5.2.6.2. The table below sets out the general conditions for each test:

Table 8

	Load (N)	Cycles per minute	Cycles (No.)
Type 1 procedure	± 60 Maximum ± 0.45	30 ± 10	1 000 ± 5
Type 2 procedure	5 Minimum 10 ± 0.05 10	30 ± 10	5 000 ± 5

Where there is insufficient strap to test over 300 mm of shift, the test may be applied over a shorter length subject to a minimum of 100 mm. "

Paragraphs 7.2.5.2.6.3. to 7.2.5.2.6.3.2., amend to read:

"7.2.5.2.6.3. Particular test conditions

7.2.5.2.6.3.1. ~~Type 1 procedure: for cases where the strap slides through the quick adjusting device. The 10 N load shall be vertically and permanently applied on one of the straps. The other strap, set horizontally, shall be attached to a device, giving the webbing a back and forth motion. The adjusting device shall be so placed that the horizontal strap of the webbing remains under tension (see Annex 5, figure 1).~~

Type 1 procedure: for cases where the strap slides through the quick adjusting device. Apply a load of 10 N, if necessary the load may be increased by 10 N steps so as to permit correct sliding, but limited to a maximum of 60 N. This load shall be vertically and permanently applied on the straps. The part of the strap set horizontally shall pass through the quick adjuster it is fitted to and shall be attached to a device, giving the webbing a back and forth motion. The quick adjusting device shall be so placed that the horizontal strap of the webbing remains under tension (see Annex 5, Figure 1). Activate the quick adjuster while pulling the straps in the direction to slacken the harness and deactivate it while pulling the straps in the direction to tighten the harness.

7.2.5.2.6.3.2. ~~Type 2 procedure: for cases where the strap changes direction in passing through a rigid part. During this test, the angles of both webbing straps shall be as shown in Annex 5, figure 2. The 5 N load shall be permanently applied. For cases where the strap changes direction more than once in passing through a rigid part, the load of 5 N may be increased so as to achieve the prescribed 300 mm of strap movement through that rigid part.~~

Type 2 procedure: for cases where the strap changes direction when passing through a rigid part. During this test, the webbing shall pass through the rigid part it is intended for and the test set-up shall reproduce the angles as in the real installation (in three dimensions), see Annex 5, Figure 2 for examples. The 10 N load shall be permanently applied. For cases where the strap changes direction more than once when passing through a rigid part, the load of 10 N may be increased by

10 N steps so as to permit correct sliding and achieve the prescribed 300 mm of strap movement through that rigid part."

Insert new paragraphs 7.2.9. to 7.2.9.2., to read:

"7.2.9. Lock-off devices

7.2.9.1. Class A devices

The Enhanced Child Restraint System and the largest manikin for which the Enhanced Child Restraint System is intended shall be set up as shown in Figure 4 below. The webbing used shall be as specified in Annex 23 to this UN Regulation. The lock-off shall be fully applied and a mark made on the belt where the belt enters the lock-off. The force gauges shall be attached to the belt via a D ring, and a force equal to twice (± 5 per cent) the mass of the heaviest dummy for the size range shall be applied for at least one second. The lower position shall be used for lock-offs in position A and the upper position for lock-offs in position B. The force shall be applied for a further nine times. A further mark shall be made on the belt where it enters the lock-off and the distance between the two marks shall be measured. During this test, the retractor shall be unlocked.

Figure 4

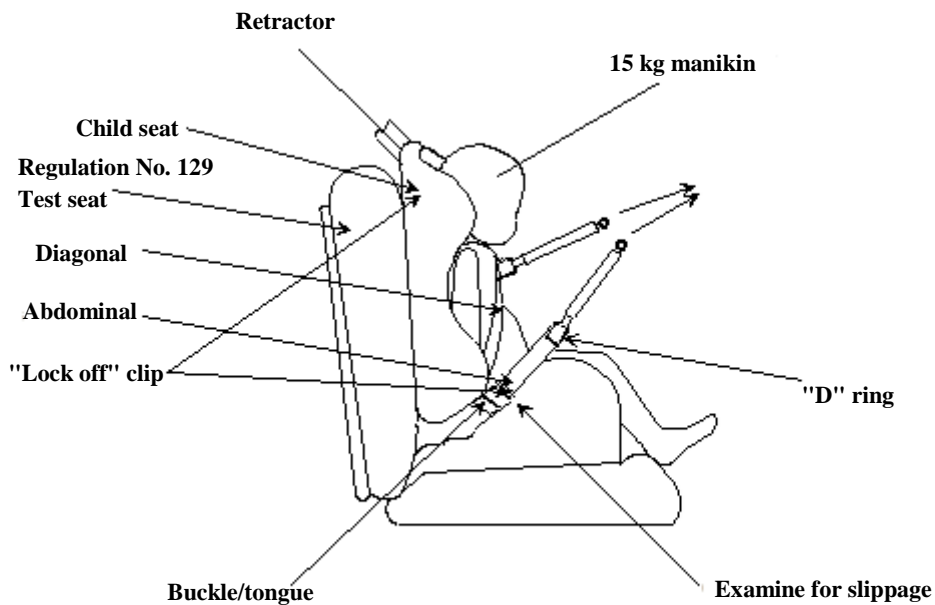

7.2.9.2. Class B devices.

The child restraint shall be firmly secured, and the webbing as specified in Annex 23 to this UN Regulation, shall pass through the lock-off and frame following the routing described in the manufacturer's instructions. The belt shall pass through the testing equipment as described in Figure 5 below and be attached to a mass of 5.25 ± 0.05 kg.

There shall be 650 ± 40 mm of free webbing between the mass and the point where the webbing leaves the frame. The lock-off shall be fully applied and a mark made on the belt where it enters the lock-off. The mass shall be raised and released so that it falls freely over a distance of 25 ± 1 mm. This shall be repeated 100 times ± 2 at a frequency of 60 ± 2 cycles per minute, to simulate the jerking action of a child restraint in a vehicle. A further mark shall be made on the belt where it enters the lock-off and the distance between the two marks shall be measured.

The lock-off device shall cover the full width of the webbing in the installed condition with Q3 dummy installed. This test is to be conducted using the same webbing angles as those formed in normal use. The free end of the lap belt portion shall be fixed. The test shall be conducted with the child restraint system firmly attached to the test bench used in the overturning or dynamic test. The loading strap can be attached to the simulated buckle."

Paragraph 8.1., amend to read:

- "8.1. The test report shall record the results of all tests and measurements including the following test data:
- (a) The type of device used for the test (acceleration or deceleration device),
 - (b) The total velocity change,
 - (c) The trolley speed immediately before impact only for deceleration sleds,
 - (d) The acceleration or deceleration curve during all the velocity change of the trolley and at least 300 ms,
 - (e) The time (in ms) when the head of the manikin reaches its maximum displacement during the performance of the dynamic test,
 - (f) The place occupied by the buckle during the tests, if it can be varied, and
 - (g) The name and address of the laboratory where tests have been performed,
 - (h) And any failure or breakage,
 - (i) The following dummy criteria: HPC, Head acceleration Cum3ms, Upper neck tension force, Upper neck moment, Chest acceleration Cum3ms, Chest deflection; Abdominal Pressure (in frontal **and rear** impact); and
 - (j) Adult **safety-belt** bench installation forces."

Paragraph 9.2.1.1., amend to read:

- "9.2.1.1. Five Enhanced Child Restraint Systems shall be subjected to the dynamic test described in paragraph 7.1.3. above. The Technical Service that conducted the type approval tests shall choose the conditions that produced the maximum horizontal head excursion during the type approval dynamic tests, excluding the conditions described in paragraphs 6.6.4.1.6.21.1., **6.6.4.1.6.1.2.** and paragraph 6.6.4.1.8.2. above. All the five Enhanced Child Restraint Systems shall be tested under the same conditions."

Insert new paragraph 14.2.3., to read:

"14.2.3. For Universal Belted seat category Enhanced Child Restraint Systems the following label shall be clearly visible on the exterior of the packing:

Notice:

This is Universal Belted Enhanced Child Restraint System. It is approved according to UN Regulation No. 129, for use primarily in "Universal seating positions" as indicated by vehicle manufacturers in the vehicle user's manual.

If in doubt, consult either the Enhanced Child Restraint System manufacturer or the retailer.

"

Paragraphs 14.2.3. to 14.2.9. (former), renumber as paragraphs 14.2.4. to 14.2.10.

Insert new paragraphs 16.8. to 16.10., to read:

- "16.8. As from the official date of entry into force of the 03 series of amendments to this UN Regulation, no Contracting Party applying this UN Regulation shall refuse to grant or refuse to accept type approvals to this UN Regulation as amended by the 03 series of amendments.**
- 16.9. Until 1 September 2020, type approvals to the preceding series of amendments to the UN Regulation which are not affected by the 03 series of amendments to the UN Regulation shall remain valid and Contracting Parties applying this UN Regulation shall continue to accept them.**
- 16.10. Until 1 September 2022, Contracting Parties applying this UN Regulation shall not refuse to grant extensions of approval to the 01 and 02 series of amendments to this UN Regulation."**

Annex 2, amend to read:

"Annex 2

1. Arrangements of the approval mark

Replace all 02 by 03

... according to which the approval has been granted.

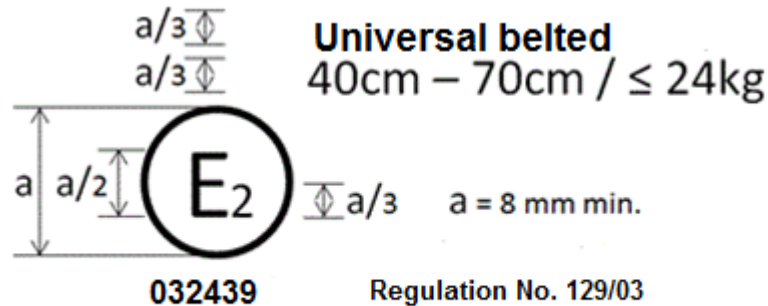

In the figure replace i-Size universal ISOFIX by Universal Belted, delete the mass limit and replace 02 by 03

The Enhanced Child Restraint System bearing the above approval mark is a device capable of being fitted in any universal seating position of the vehicle and of being used for the 40 cm - 70 cm size range; it is approved in France (E 2) under the number 032439. The approval number indicates that the approval was granted in accordance with the requirements of the UN Regulation on approval of Universal Belted Enhanced Child Restraint Systems used on-board of motor vehicles as amended by the 03 series of amendments. In addition the name of the UN Regulation must be identified on the approval mark followed by the series of amendment according to which the approval has been granted.

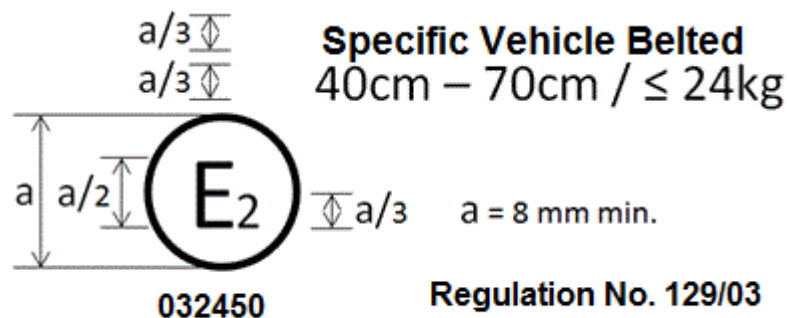

The Enhanced Child Restraint System bearing the above approval mark is a device not capable of being fitted in every vehicle and capable of being used for the 40 cm - 70 cm size range; it is approved in France (E 2) under the number 032450. The approval number indicates that the approval was granted in accordance with the requirements of the UN Regulation on the approval of Specific vehicle Belted Enhanced Child Restraint Systems used on-board of

motor vehicles as amended by the 03 series of amendments. In addition the name of the UN Regulation must be identified on the approval mark followed by the series of amendment according to which the approval has been granted.

In case the Enhanced Child Restraint System is equipped with a module, the size range and the mass limit are not on the approval mark but on the module mark.

2. Arrangements of the approval mark in combination with a module mark

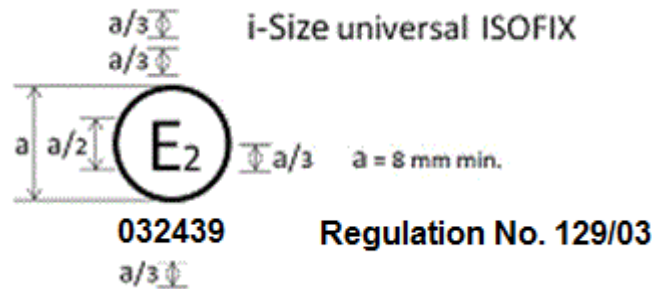

The Enhanced Child Restraint System bearing the above approval mark is a device, including module(s), capable of being fitted in any i-size compatible vehicle seating position. It is approved in France (E 2) under the number 0232439. The approval number indicates that the approval was granted in accordance with the requirements of the UN Regulation concerning the approval of Enhanced Child Restraint Systems used on-board of motor vehicles as amended by the 023 series of amendments. In addition the name of the UN Regulation has to be identified on the approval mark followed by the series of amendment according to which the approval has been granted.

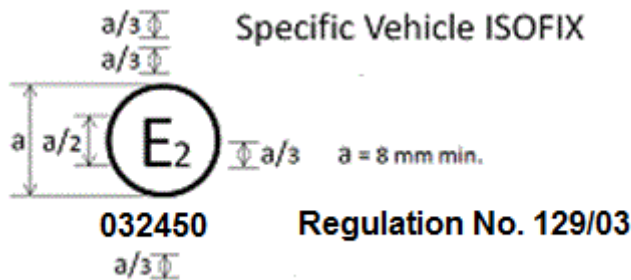

The Enhanced Child Restraint System bearing the above approval mark is a device, including module(s), not capable of being fitted in every vehicle. It is approved in France (E 2) under the number 0232450. The approval number indicates that the approval was granted in accordance with the requirements of the UN Regulation concerning the approval of Specific vehicle ISOFIX Enhanced Child Restraint Systems used on-board of motor vehicles as amended by the 023 series of amendments. In addition the name of the UN Regulation has to be identified on the approval mark followed by the series of amendment according to which the approval has been granted.

2.1. Arrangements of the module mark in combination with an approval mark

- 2.1.1. Where a module is approved for use with more than one base, the individual base and module combinations shall be indicated on the module in separate module marks, each bearing their applicable size ranges.

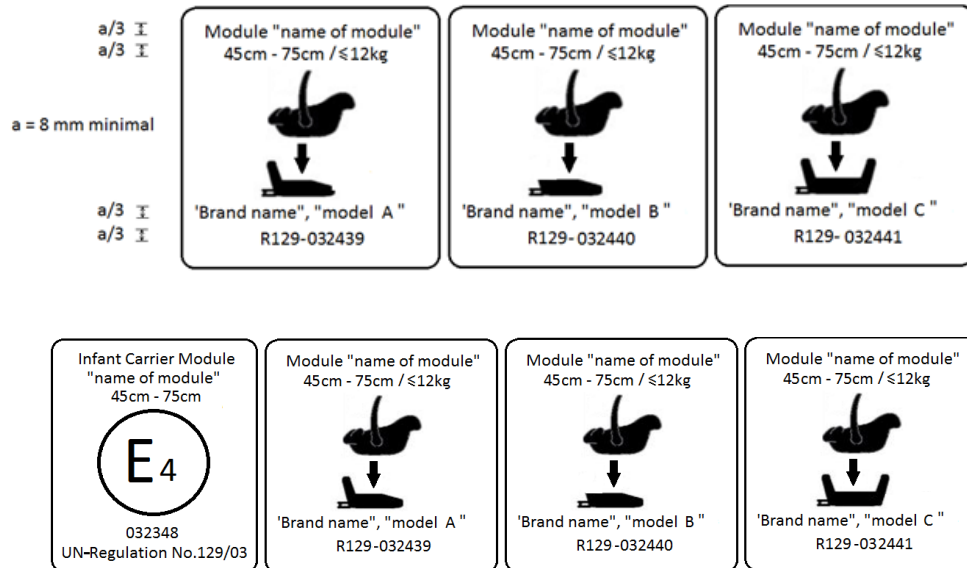

A Module that bears an approval mark for the stand-alone mode of use and a module mark for its use on three different bases, shall carry the following arrangement of approval and module marks:

The module bearing the above marks is capable of being used as an Universal Belted Enhanced Child Restraint System for the 45 cm - 75 cm size range; it is approved according to UN Regulation No. 129-03 under the number 032348.

The module can also be used as a module in combination with the base "brand name and model A", for the 45 cm - 75 cm size range and mass limit of 12 kg; approved according to UN Regulation No. 129-03 under the number 032439.

The module can also be used as a module in combination with the base "brand name and model B", for the 45 cm - 75 cm size range and mass limit of 12 kg; approved according to UN Regulation No. 129-03 under the number 032440.

The module can also be used as a module in combination with the base "brand name and model C", for the 45 cm - 75 cm size range and mass limit of 12 kg; approved according to UN Regulation No. 129-03 under the number 032441.

The approval numbers indicate that the approval was granted in accordance with the requirements of the UN Regulation on the approval of Enhanced Child Restraint Systems used on-board of motor vehicles as amended by the 03 series of amendments.

- 2.1.2. Where a module is capable of being installed in different orientations, separate module marks shall be indicated on the module, each bearing their applicable size ranges.

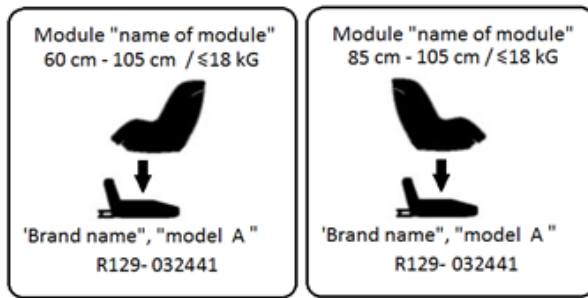

The module bearing the above marks is capable of being used in a rearward facing mode with the base "brand name and model A", for the 60 cm - 105 cm size range and with a mass limit of 18 kg; approved according to UN Regulation No. 129-03 under the number 032441.

The module bearing the above marks is also capable of being used in a forward facing mode with the base "brand name and model A", for the 85 cm - 105 cm size range and with a mass limit of 18 kg; approved according to UN Regulation No. 129-03 under the same number 032441.

The approval number indicates that the approval was granted in accordance with the requirements of the UN Regulation concerning the approval of Enhanced Child Restraint Systems used on-board motor vehicles as amended by the 03 series of amendments.

- 2.2. Examples of the symbols to be used on the module mark are given in the figures below. As chosen by the Enhanced Child Restraint Systems manufacturer, one of the symbols or an equivalent shall be used on the module mark.

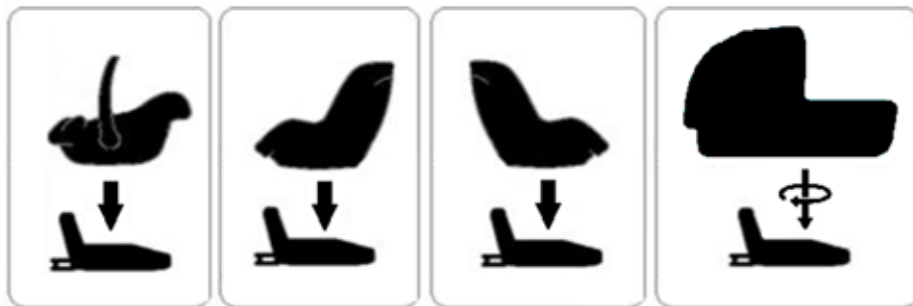

"

Annex 5, Figures 1 and 2 , amend to read:

"Annex 5

Abrasion and microslip test

Figure 1
Procedure type 1

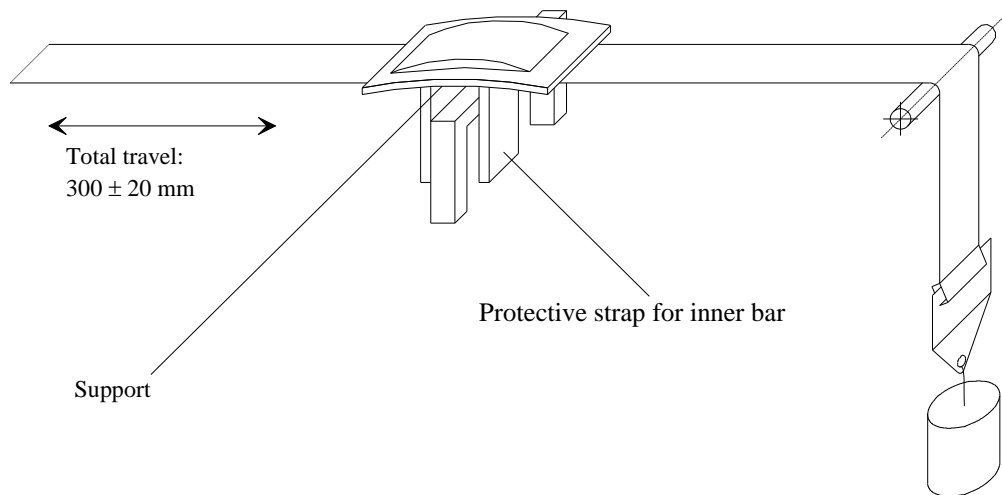

$F = 10 \pm 0.1 \text{ N}$, can be increased up to maximum $F = 60 \pm 0.5 \text{ N}$ (see table 8, paragraph 7.2.5.2.6.2.)

Example a

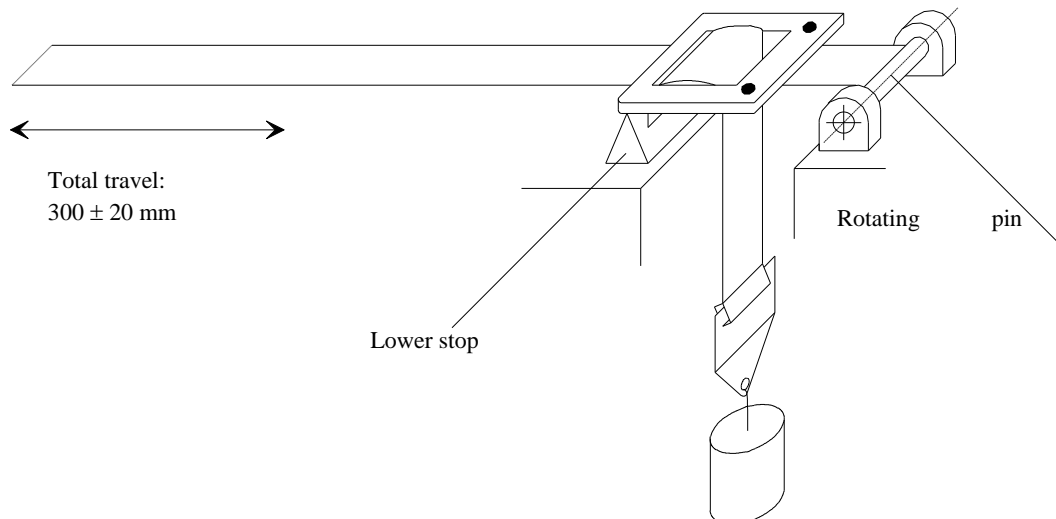

Example b
 Examples of test arrangements corresponding to the type of adjusting device

$F = 10 \pm 0.1 \text{ N}$, can be increased up to maximum $F = 60 \pm 0.5 \text{ N}$ (see table 8, paragraph 7.2.5.2.6.2.)

Figure 2
Procedure type 2
 Following two examples of test set up

Example 1

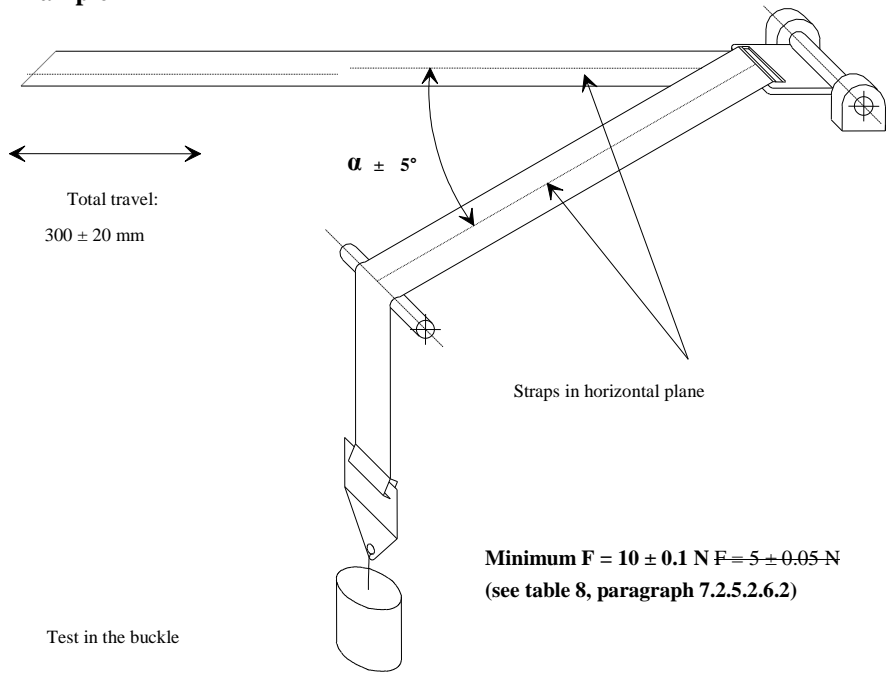

Example 2

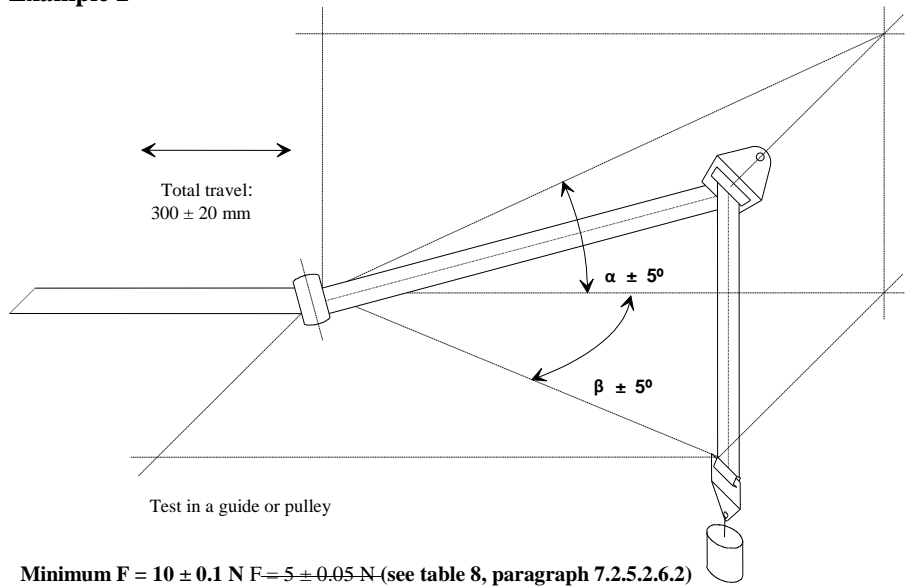

Where α and β reproduce the angles as in the real installation (in three dimensions)
 ..."

Annex 6, Appendix 2, insert new figure 5:

"Figure 5
Lower strap anchorages (LSA 1, LSA 2, LSA 3 and LSA 4)

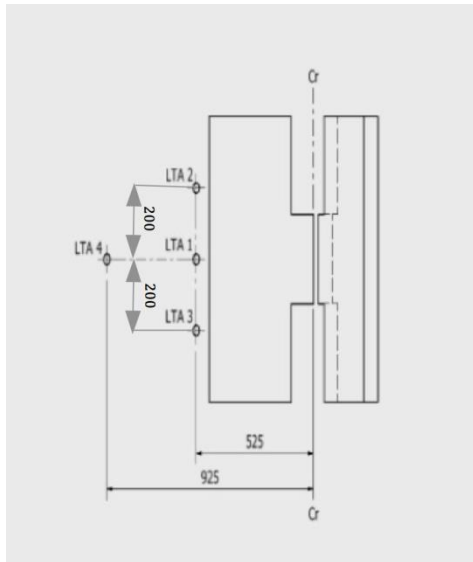

Annex 8, Note of Table 1, amend to read:

"...
The installation of Abdominal Pressure Twin Sensors (APTS) in frontal **and rear** impact may add up 0.2 kg to the Q1.5 and 0.5kg to the Q3, Q6 and Q10 dummies."

Annex 8, Table 2, amend to read:

"Table 2
Q-dummy dimensions

No.		Q0	Q1	Q1.5	Q3	Q6	Q10 (design targets)
<i>Dimensions in mm</i>							
17	Seating height (head tilted forward)	355 ± 9	479 ± 9	499 ± 9	544 ± 9	601 ± 9	<748 ± 9 733.7 ± 9
18	Shoulder height (sitting)	225 ± 7 255 ± 5	298 ± 7	309 ± 7	329 ± 7	362 ± 7	473 ± 7
	Stature (head tilted forward)	-	740 ± 9	800 ± 9	985 ± 9	1143 ± 9	<1443 ± 9 1453.2 ± 12
5	Chest depth	-	114 ± 5	113 ± 5	146 ± 5	141 ± 5	171 ± 5
15	Shoulder width	230 ± 7 145 ± 5	227 ± 7	227 ± 7	259 ± 7	305 ± 7	334.8 ± 7
12	Hip width	-	191 ± 7	194 ± 7	200 ± 7	223 ± 7	270 ± 7

No.		Q0	Q1	Q1.5	Q3	Q6	Q10 (design targets)
1	Back of buttocks to front of knees	130 ± 5	211 ± 5	235 ± 5	305 ± 5	366 ± 5	485.4 ± 5± 6
2	Back of buttocks to popliteus	-	161 ± 5	185 ± 5	253 ± 5	299 ± 5	414.9 ± 5± 6
21	Thigh height, sitting		69	72	79	92	114 ± 3
	Height of spacer device for positioning of dummy ¹		229 ± 2	237 ± 2	250 ± 2	270 ± 2	359 ± 2

"

Annex 12, paragraph 2.2.1.4., Notes, amend to read:

"Notes:

MH means harder ~~configuration condition~~ (the least good results obtained in approval or extension of approval) LH signifies a less hard ~~configuration condition~~."

Annex 18, amend to read:

"Annex 18

Geometrical dimensions of Enhanced Child Restraint Systems

....

Figure 3

Side and Front View of the measuring device for measurements applicable to Enhanced Child Restraint Systems that feature an impact shield

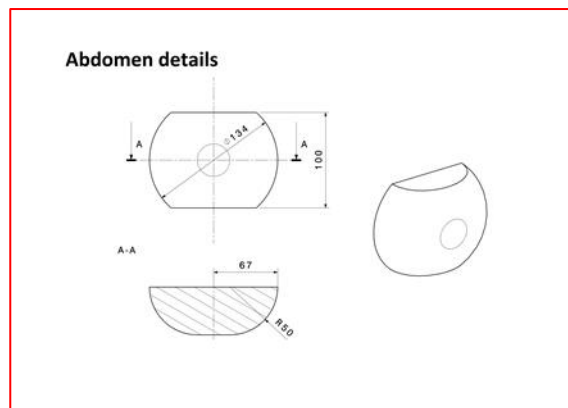
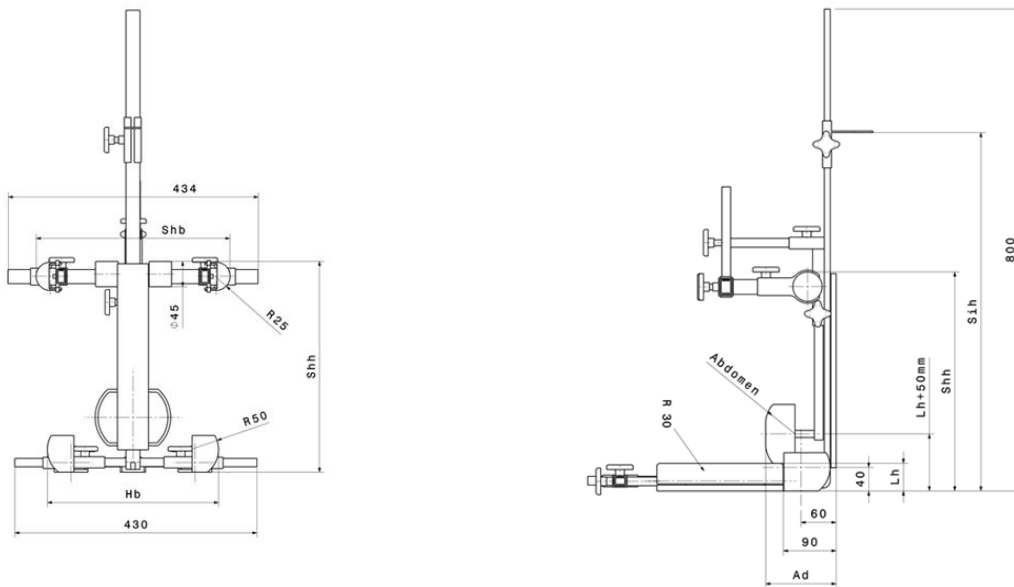

All dimensions in mm"

Paragraph "Internal geometry assessment method", replace "ECRS" by "Enhanced Child Restraint System".

Insert new paragraph 3, to read:

"3. Stature Calculation

The measurements taken in Sections 1 and 2 shall then be compared to the values shown in Annex 18, Table 1.

Interpolation between the values shown in the table is allowed at one-centimetre intervals.

For each measurement, the corresponding stature at the nearest whole lower centimetre shall be calculated.

Maximum stature

For the measurements B, C, D, E2, F2 and G2, the measured value must be greater than or equal to the value shown in the table to meet the stature requirement.

For example to declare a stature of 105 cm the measured sitting height after applying tolerances must be greater or equal to 61.8 cm.

The maximum stature is the smallest stature calculated from the measurements B, C, D, E2, F2 and G2.

Minimum stature

For the measurements E1, F1 and G1, the measured value must be less than or equal to the value shown in the table to meet the stature requirement.

For example to declare a stature of 100 cm, the measured shoulder height after applying tolerances must be less than or equal to 32.4 cm.

The minimum stature is the largest stature calculated from the measurements E1, F1 and G1."

Annex 20, replace "ECRS" by "Enhanced Child Restraint System"

Annex 22, shall be deleted.

Annex 23, amend to read:

"1. The safety-belt for the dynamic test and for the maximum length requirements shall be made according to the ~~configuration~~ **definition** shown in Figure 1. These are a three-point retracting belt system.

..."

Insert new Annex 25, to read:

"Annex 25

Additional attachment points required for securing rearward facing Enhanced Child Restraint System, of category Specific vehicle Belted, to motor vehicles.

1. This annex applies only to the additional anchorages for attaching Enhanced Child Restraint in the Specific vehicle Belted category or to bars or other special items used to secure child-restraining devices to the bodywork, whether or not they make use of UN Regulation No. 14 or UN Regulation No. [xx] on ISOFIX anchorage systems, ISOFIX top tether anchorages and i-Size seating positions.
2. The anchorages shall be determined by the manufacturer of the child restraint system and details shall be submitted for approval to the Technical Service conducting the tests.

The Technical Services may consider information obtained from the vehicle manufacturer.
3. The manufacturer of the child restraint shall provide the necessary parts for fitting the anchorages and a special plan for each vehicle showing their exact location.

4. **The child restraint manufacturer shall indicate if the anchorages required for attaching the restraint to the vehicle structure are in accordance with the position and strength requirements of paragraph 3. onwards in the recommendation given to Governments intending to adopt specific requirements relating to anchorages for child restraints used in passenger cars."**

II. Justification

1. The proposed amendment includes Enhanced Child Restraint Systems from the universal belted or specific to vehicle belted categories into the scope of UN Regulation No. 129. This proposal represents Phase 3 of the UN Regulation.
 2. The text includes all changes proposed during GRSP sessions until its sixty-first session (8-12 May 2017) as well as those proposed by the IWG CRS until its sixty-seventh session (Brussels, 31 August 2017).
 3. This proposal refers to the 02 series of amendments to UN Regulation No. 129, including the following amendments:
 - (a) Proposal for supplement 1 to the 02 series of amendments - ECE/TRANS/WP.29/2017/63;
 - (b) Proposal for supplement 2 to the 02 series of amendments - ECE/TRANS/WP.29/2017/126.
-