

Indian comments on GRE 2017/12

A. Proposal

1. Replace figure in Annex 4 , Fig 2a

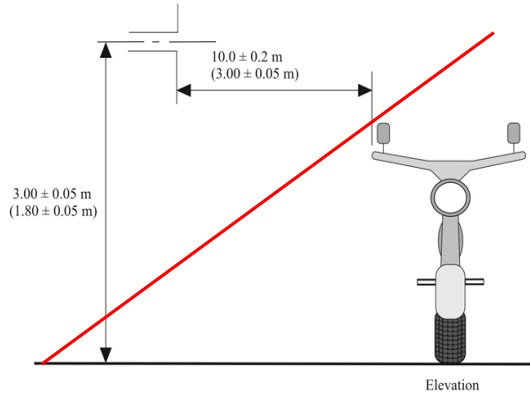

By

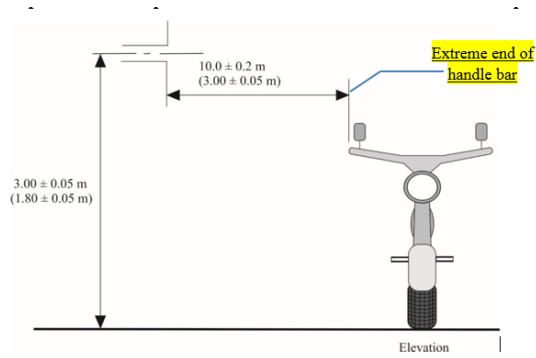

2. Replace figure in Annex 4 , Fig 2b

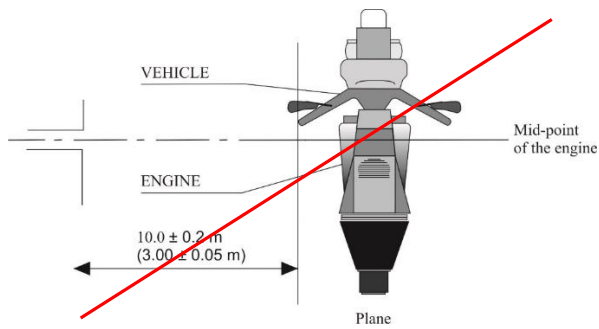

By

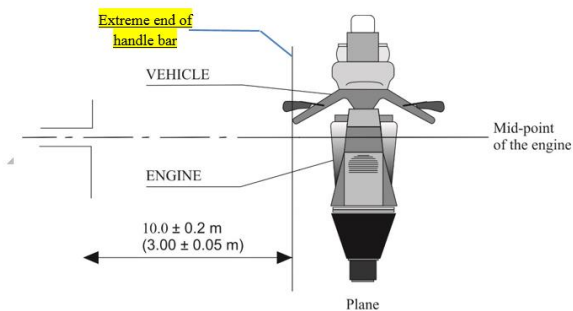

3. Replace figure in Annex 6 Appendix 1 Figure 2

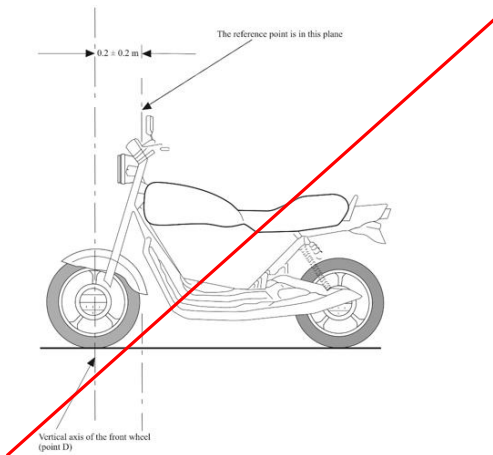

By

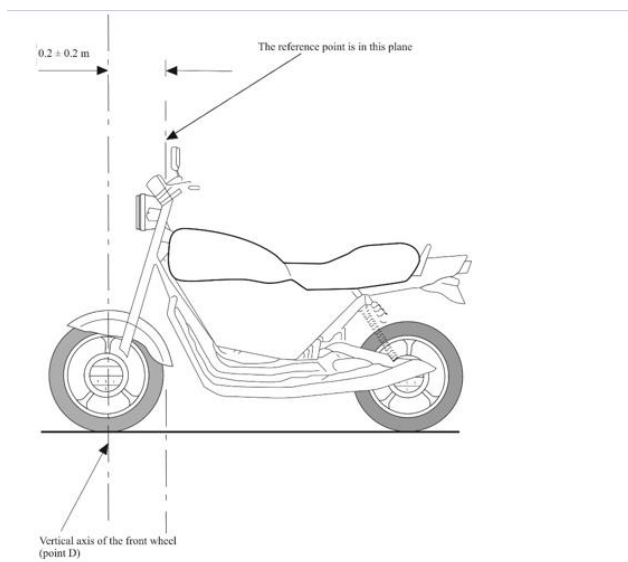

B. Justification

For Sr No 1&2 : To bring in more clarity & uniformity of measurement distance between Antenna & vehicle.

For Sr No3 : To align as per Annex 6 – Appendix 1 figure 1 “Three wheeled vehicle”