

Rationale for the proposed amendments to Regulation No. 110 (CNG/LNG vehicles)

The text reproduced below was prepared by the expert from the International Organization for Standardization (ISO). The expert is the Convener of the Working Group (ISO TC 58/SC 3/WG 17) responsible for the ISO 11439 standard *High pressure cylinders for the on-board storage of natural gas as a fuel for automotive vehicles*. The proposed changes are for the purpose of harmonizing the CNG cylinder requirements in Regulation No. 110 with the requirements in the ISO 11439: 2013 standard.

The proposed changes in ECE/TRANS/WP.29/GRSG/2016/22 are a follow-up to the discussion that occurred during the 110th session of the Working Party on General Safety Provisions (see report ECE/TRANS/WP.29/GRSG/89, paras. 33-34). The modifications to the current text of UN Regulation No. 110 are marked by strikethroughs and in bold characters.

Justification

The justification (*marked in red characters*) for this proposal was previously presented in the document *ECE R110 Annex 3 & ISO 11439 “High pressure cylinders for the onboard storage of natural gas as a fuel for automotive vehicles”*, Informal document GRSG-106-29 (106th GRSG, 5-9 May 2014, agenda item 8).

Proposal - Alignment with ISO 11439:2013 - Proposed Revisions to:

E/ECE/324/Rev.2/Add.109/Rev.3
E/ECE/TRANS/505/Rev.2/Add.109/Rev.3

Regulation No. 110

Uniform provisions concerning the approval of:

- I. Specific components of motor vehicles using compressed natural gas (CNG) and/or liquefied natural gas (LNG) in their propulsion system
- II. Vehicles with regard to the installation of specific components of an approved type for the use of compressed natural gas (CNG) and/or liquefied natural gas (LNG) in their propulsion system

Prepared By:

Craig Webster, P.Eng.
Convener – ISO TC 58/SC 3/WG 17 for the ISO 11439 Standard

craig.webster@csagroup.org

2. References

ASTM Standards

~~ASTM B117-90 Test method of Salt Spray (Fog) Testing~~

Replaced by reference to ISO 9227 equivalent.

~~ASTM B154-92 Mercurous Nitrate Test for Copper and Copper Alloys~~

No longer use mercurous nitrate as very dangerous chemical to handle – replaced by less dangerous test specified under 15500-13 for PRD testing per tests defined in 15500-2.

~~ASTM D522-923a Mandrel Bend Test of Attached Organic Coatings~~

Corrected reference.

~~ASTM D2344-84 Test Method for Apparent interlaminar Shear Strength of Parallel Fibre Composites by Short Beam Method~~

Replaced by reference to ISO 14130 equivalent.

~~ASTM D2794-923 Test Method for Resistance of Organic Coatings to the Effects of Rapid Deformation (Impact)~~

Corrected date of reference.

ASTM D3359 Standard Test Methods for Measuring Adhesion by Tape Test

Replacement for ISO 4624 (incorrect reference)

ASTM D4814 Standard Specification for Automotive Spark-Ignition Engine Fuel

Standard added for Environmental test chemical.

~~ASTM D3418-83 Test Method for Transition Temperatures Polymers by Thermal Analysis~~

Editorial.

~~ASTM E647-93 Standard Test Method for Measurement of Fatigue Crack Growth Rates~~

No longer required, as no longer calculate fatigue crack growth rates in the Regulation (see also F.3.1)

~~ASTM E813-89 Test Method for JIC, a Measure of Fracture Toughness~~

No longer required, as fracture mechanics calculation methods deleted

~~ASTM G53-93 Standard Practice for Operating Light and Water Exposure Apparatus (Fluorescent UV Condensation Type) for Exposure of nonmetallic Materials~~

Superseded by ASTM G154 (see also A.9.1).

ASTM G154-12a Standard Practice for Operating Fluorescent Light Apparatus for UV Exposure of Nonmetallic Materials

ASTM replacement for ASTM G53 (see also A.9.1).

BSI Standards³

~~BS 5045 Part 1 (1982) Transportable Gas Containers—Specification for Seamless Steel Gas Containers Above 0.5 litre Water Capacity~~

Replaced by equivalent ultrasonic requirements as specified in ISO 9809-1 standard.

~~BS 7448-91 Fracture Mechanics Toughness Tests Part I—Method for Determination of K_{IC}, Critical COD and Critical J Values of BS PD 6493-1991. Guidance an Methods for Assessing the A Acceptability of Flaws in Fusion Welded Structures; Metallic Materials~~

Deleted since the use of fracture mechanics calculations for leak-before-break are no longer part of a performance standard.

EN Standards

~~EN 13322-2:2003 Transportable gas cylinders—Refillable welded steel gas cylinders—Design and construction—Part 2: Stainless steel~~

Stainless steels are no longer part of the regulation.

~~EN ISO 5817:2003 Arc-welded joints in steel; guidance on quality levels for imperfections~~

Welding is no longer part of the regulation.

~~EN 895:1995 Destructive tests on welds in metallic materials. Transverse tensile test~~

Welding is no longer part of the regulation.

~~EN 910:1996 Destructive test methods on welds in metallic materials. Bend tests~~

Welding is no longer part of the regulation.

~~EN 1435:1997 Non-destructive examination of welds. Radiographic examination of welded joints~~

Welding is no longer part of the regulation.

~~EN 6892-1:2009 Metallic materials. Tensile test~~

Replaced by reference to equivalent ISO 6892 standard.

~~EN 10045-1:1990 Charpy impact test on metallic materials. Test method (V and U notches)~~

Replaced by reference to equivalent ISO 148-1 standard.

ISO Standards

~~ISO 148-1983 Steel—Charpy Impact Test (v-notch)~~

Replaced by ISO 148-1 (updated version)

ISO 148-1, Metallic materials – Charpy pendulum impact test – Part 1: Test method

Updated reference.

~~ISO 527-Pt 1-93 Plastics—Determination of Tensile Properties—Part I: General principles-2, Plastics – Determination of tensile properties – Part 2: Test conditions for moulding and extrusion plastics~~

Updated reference.

~~ISO 642-79 Steel Hardenability Test by End Quenching (Jominy Test)~~

The hardenability test is no longer a requirement for steels in the ISO 9809 series of standards. Suitability of the steel for CNG service is determined by performance tests.

ISO 9227 Corrosion tests in artificial Atmospheres – Salt spray tests

ISO equivalent replacement for ASTM B117.

ISO 14130 Fibre-reinforced plastic composites – Determination of apparent interlaminar shear strength by short-beam method

ISO equivalent replacement for ASTM D2344.

ISO 2808-94 Paints and Varnishes – Determination of film thickness

Editorial.

~~ISO 3628-78 Glass Reinforced Materials – Determination of Tensile Properties~~

ISO 3628 is for photography processing chemicals. The correct reference is ISO 527-2 Plastics -- Determination of tensile properties -- Part 2: Test conditions for moulding and extrusion plastics.

~~ISO 4624-78 Plastics and Varnishes – Pull-off Test for adhesion~~

Replaced by use of ASTM D3359 as ISO 4624 was found not to be equivalent to the ASTM standard.

ISO 6982-84 **6892** Metallic Materials – Tensile Testing

Wrong designation was previously used.

ISO 6506-1981 Metallic Materials – Hardness test – Brinell Test

Editorial.

~~ISO 6508-1986 Metallic Materials – Hardness Tests – Rockwell Test (Scales, ABCDEFGHK)~~

This standard is not referenced in text of the Regulation.

~~ISO/DIS 7866-1992 Refillable Transportable Seamless Aluminium Alloy gas Cylinders for Worldwide Usage – Design, construction and testing Manufacture and Acceptance~~

Updated reference.

~~ISO/DIS 9809 Transportable Seamless Steel Gas Cylinders Design, Construction and Testing – Part I: Quenched and Tempered Steel Cylinders with Tensile Strength < 1,100 MPa~~

ISO 9809-1, Gas cylinders — Refillable seamless steel gas cylinders — Design, construction and testing — Part 1: Quenched and tempered steel cylinders with tensile strength less than 1 100 MPa

Updated reference as ISO 9809 is no longer a DIS.

ISO 9809-2, Gas cylinders — Refillable seamless steel gas cylinders — Design, construction and testing — Part 2: Quenched and tempered steel cylinders with tensile strength greater than or equal to 1 100 MPa

ISO 9809-3, Gas cylinders — Refillable seamless steel gas cylinders — Design, construction and testing — Part 3: Normalized steel cylinders

Expanded the use of the ISO 9809 series of standards for steel cylinders.

~~ISO/DIS 12737 Metallic Materials – Determination of the Plane Strain Fracture Toughness~~

No longer use fracture mechanics calculation approach in the standard – rely instead on performance tests.

ISO 15403-1 Natural gas — Natural gas for use as a compressed fuel for vehicles — Part 1: Designation of the quality

ISO/TR 15403-2 Natural gas — Natural gas for use as a compressed fuel for vehicles — Part 2: Specification of the quality

Standards for natural gas quality were previously not available. These replace the use of SAE J1616.

ISO 15500-13, Road vehicles – Compressed natural gas (CNG) fuel system components — Part 13: Pressure relief device (PRD)

Comprehensive test program for PRDs compared to the single test previously used in A.24 of the Regulation.

~~ISO 11439 Gas cylinders — High pressure cylinders for the on-board storage of natural gas as a fuel for automotive vehicles~~

No need to reference ISO 11439 as all requirements in the standard have been included in ECE R110.

4. Definitions

~~4.4. "Working pressure" means the maximum pressure to which a component is designed to be subjected to and which is the basis for determining the strength of the component under consideration. For CNG cylinder, the settled pressure of 20 MPa at a uniform temperature of 15 °C. For LNG tank, the pressure of the LNG tank primary relief valve setting.~~

Specification of 20 MPa as the only working pressure for CNG has been removed, as there are parts of the world that use 25 MPa and 35 MPa for CNG.

~~4.62. "Maximum developed pressure" means the settled pressure developed when gas in a cylinder filled to the working pressure is raised to the maximum service temperature.~~

This term is not used in the Regulation.

Annex 3A

Gas cylinders - High pressure cylinder for the on-board storage of CNG compressed natural gas as a fuel for automotive vehicles

1. Scope

~~Service conditions to which the cylinders will be subjected are detailed in paragraph 4. of this annex. This annex is based upon a working pressure for natural gas as a fuel of 20 MPa settled at 15 °C with a maximum filling pressure of 26 MPa. Other working pressures can be accommodated by adjusting the pressure by the appropriate factor (ratio). For example, a 25 MPa working pressure system will require pressures to be multiplied by 1.25. Although this annex uses 20 MPa as a reference working pressure, other working pressures can be used.~~

There is no scientific reason to limit CNG working pressure to 20 MPa – other working pressures (25 MPa and 35 MPa) for CNG have been used without problems elsewhere in the world.

4 Service conditions

4.2. Maximum pressures

This annex is based upon a working pressure of 20 MPa settled at 15 °C for natural gas as a fuel with a maximum filling pressure of 26 MPa. Other working pressures may be accommodated by adjusting the pressure by the appropriate factor (ratio); e.g. a 24 MPa working pressure system will require pressures to be multiplied by 1,20. Except where pressures have been adjusted in this way, the cylinder pressure shall be limited to the following:

The added statement clarifies the fact that other working pressures may be used, and how testing pressures must be adjusted accordingly.

- (a) A pressure that would settle to 20 MPa at a settled temperature of 15 °C;
- (b) 26 MPa, immediately after filling, regardless of temperature;

4.3 Maximum number of filling cycles

Cylinders are designed to be filled up to ~~a settled pressure of 20 MPa (200 bar) at a settled gas temperature of 15 °C for up to 1,000 times per year~~ of service.

This statement regarding fill pressures is already made in clause 4.2 above.

4.5. Gas composition

4.5.1 General

Cylinders shall be designed to tolerate being filled with natural gas meeting the specification of ISO 15403-1 and ISO/TR 15403-2, and either of dry gas or wet gas as described in 4.5.2 or 4.5.3, respectively. Methanol and/or glycol shall not be deliberately added to the natural gas. ~~Cylinder should be designed to tolerate being filled with natural gas meeting either of the following three conditions:~~

~~(a) SAE J1616~~

~~(b) 4.5.2 Dry gas~~

~~Water vapour would normally be limited to less than 32 mg/m³ at a pressure dew point of -9 °C at 20 MPa. There would be no constituent limits for dry gas, except for:~~

~~Hydrogen sulphide and other soluble sulphides: 23 mg/m³~~

~~Oxygen: 1 per cent by volume~~

~~Hydrogen shall be limited to 2 per cent by volume when cylinders are manufactured from steel with an ultimate tensile strength exceeding 950 MPa;~~

~~(c) 4.5.3 Wet gas~~

~~Gas that contains water content higher than b) normally meets the following constituent limits;~~

~~Hydrogen sulphide and other soluble sulphides: 23 mg/m³~~

~~Oxygen: 1 per cent by volume~~

~~Carbon dioxide: 4.3 per cent by volume~~

~~Hydrogen: 0.1 per cent by volume~~

~~Under wet gas conditions, a minimum of 1 mg of compressor oil per kg of y to protect metallic cylinders and liners.~~

Replaced reference to the SAE J1616 natural gas specification with the ISO 15403 specifications for natural gas, and decreased the carbon dioxide limit to 3 per cent by volume to correspond with the value currently in ISO 11439.

5. **Design Type approval procedure**

5.1. General

The following information shall be submitted by the cylinder designer with a request for approval to the Type Approval Authority:

The cylinder design is not approved, but the Type is approved - the wording in the Regulation itself says "Type Approval Authority".

6. Requirements applicable to all cylinder types

6.1. General

The following requirements are generally applicable to the cylinder types specified in paragraphs 7. to 10. of this annex. The design of cylinders shall cover all relevant aspects which are necessary to ensure that every cylinder produced according to the design is fit for its purpose for the specified service life; ~~Type CNG 1 steel cylinders designed in accordance with ISO 9809 and meeting all the requirements therein are only required to meet the requirements of paragraphs 6.3.2.4. and 6.9. to 6.13. below.~~

It was stated that ISO 9809 designs are acceptable for CNG service, provided they meet the materials and design test requirements in ISO 11439. Instead, it has been decided that the preferred approach is to give ISO 9809 designs exemptions from certain tests in ISO 11439. These exemptions are provided in clause 7.4 of the Regulation.

6.3.2. Steel

6.3.2.1. Composition

(b) Nickel, chromium, molybdenum, boron and vanadium contents, and any other alloying elements intentionally added. The following limits shall not be exceeded in the cast analysis:

Tensile strength	< 950 MPa	□ 950 MPa
Sulphur	0.020 per cent	0.010 per cent
Phosphorus	0.020 per cent	0.020 per cent
Sulphur and phosphorus	0.030 per cent	0.025 per cent

~~When carbon boron steel is used, a hardenability test in accordance with ISO 642, shall be performed on the first and last ingot or slab of each heat of steel. The hardness as measured in a distance of 7.9 mm from the quenched end, shall be within the range 33-53 HRC, or 327-560 HV, and shall be certified by the material manufacturer;~~

The ISO 9809 series of standards no longer recognize the higher level of impurities previously allowed for lower strength steels. They only require the one set of limits for steels regardless of tensile strength.

The hardenability test is no longer a requirement for steels in the ISO 9809 series of standards. Suitability of the steel for CNG service is determined by performance tests.

6.3.2.4. ~~Bending properties~~

~~The bending properties of the welded stainless steel in the finished liner shall be determined in accordance with paragraph A.3. (Appendix A to this annex).~~

Welded steel is no longer accepted in the R.110 regulation.

6.3.2.5. ~~Macroscopic weld examination~~

~~A macroscopic weld examination for each type of welding procedure shall be performed. It shall show complete fusion and shall be free of any assembly faults or unacceptable defects as specified according to level C in EN ISO 5817.~~

Welds are no longer accepted in the R.110 regulation.

6.3.3. Aluminium

6.3.3.4. Tensile properties

The mechanical properties of the aluminium alloy in the finished cylinder shall be determined in accordance with paragraph A.1. (Appendix A to this annex). The elongation for aluminium **cylinder material in Type CNG-1 cylinders and aluminum liner material in Type CNG-2 cylinders** shall be at least 12 per cent. **The elongation for aluminum liner material in Type CNG-3 cylinders shall meet the manufacturer's design specifications.**

Type 3 designs do not require elongation limitations, as the carbon fibre overwrap prevents the aluminum elongation from exceeding the 2% elongation of the carbon fibre.

6.3.6 Plastic liners

The tensile yield strength and ultimate elongation shall be determined in accordance with paragraph A.22. (Appendix A to this annex). Tests shall demonstrate the ductile properties of the plastic liner material at temperatures of -50 °C or lower by meeting the values specified by the manufacturer; the polymeric material shall be compatible with the service conditions specified in paragraph 4. of this annex. In accordance with the method described in paragraph A.23. (Appendix A to this annex), the softening temperature shall be at least 90 °C, ~~and the melting temperature at least 100 °C.~~

The increased softening temperature requirement to 100°C is in consideration of the high temperatures generated in Type 4 cylinders during fast filling. The melting temperature was eliminated as the ISO 306 standard "Plastics -- Thermoplastic materials -- Determination of Vicat softening temperature (VST)", does not determine the melting point.

6.4. Test pressure

The minimum test pressure used in manufacture shall be ~~30 MPa~~ **1,5 times working pressure;**

Changed to 1,5 times working pressure, to recognize the fact that other working pressures may be used.

6.7. Leak-before-break (LBB) assessment

Types CNG-1, CNG-2 and CNG-3 cylinders shall demonstrate Leak-Before-Break (LBB) performance. The LBB performance test shall be carried out in accordance with paragraph A.6. (Appendix A to this annex). Demonstration of LBB performance is not required for cylinder designs that provide a fatigue life exceeding 45,000 pressure cycles when tested in accordance with paragraph A.13. (Appendix A to this annex). ~~Two methods of LBB assessment are included for information in Appendix F to this annex.~~

Reduced to only one method (performance test), by eliminating the calculation approach. The accuracy of the calculation approach could not be readily verified by Type Approval Authorities.

6.9 Fire Protection

All cylinders shall be protected from fire with pressure relief devices. The cylinder, its materials, pressure relief devices and any added insulation or protective material shall be designed collectively to ensure adequate safety during fire conditions in the test specified in paragraph A.15. (Appendix A to this annex).

~~Pressure relief devices shall be tested in accordance with paragraph A.24. (Appendix A to this annex).~~ **conform to ISO 15500-13.**

The new ISO 15500-13 standard provides a far more thorough test program for evaluating the long-term integrity and performance of pressure relief devices.

6.12. Exterior environmental protection

The exterior of cylinders shall meet the requirements of the environmental test conditions of paragraph A.14. (Appendix A to this annex). Exterior protection may be provided by using any of the following:

- (a) A surface finish giving adequate protection (e.g. metal sprayed on aluminium, anodizing); or
- (b) The use of a suitable fibre and matrix material (e.g. carbon fibre in resin); or
- (c) A protective coating (e.g. organic coating, paint) that shall meet the requirements of paragraph A.9. (Appendix A to this annex).

Any coatings applied to cylinders shall be such that the application process does not adversely affect the mechanical properties of the cylinder. The coating shall be designed to facilitate subsequent in service inspection and the manufacturer shall provide guidance on coating treatment during such inspection to ensure the continued integrity of the cylinder. ~~Manufacturers are advised that an environmental performance test that evaluates the suitability of coating systems is provided in the informative Appendix H to this annex.~~

The test in Appendix H has been moved into A.14 as a mandatory test. The mandatory use of the Appendix H test is primarily the result of in-service stress corrosion cracking failures of CNG cylinders reinforced with glass fibre composites.

6.15. Production examinations and tests

6.15.1. General

Production examinations and tests shall be carried out on all cylinders produced in a batch. Each cylinder shall be examined during manufacture and after completion by the following means:

- (a) Ultrasonic scanning (or demonstrated equivalent) of metallic cylinders and liners in accordance with ~~BS 5045, Part 1~~ **ISO 9809-1, Annex B**, or demonstrated equivalent method, to confirm that the maximum defect size present is smaller than the size specified in the design;

Replaced the BS standard with an equivalent ISO standard.

6.15.2. Maximum defect size

For type CNG-1, CNG-2 and CNG-3 designs, the maximum defect size at any location in the metal cylinder or metal liner that will not grow to a critical size within the specified service life shall be determined. The critical defect size is defined as the limiting through-wall (cylinder or liner) thickness defect that would allow stored gas to be discharged without rupturing the cylinder. Defect sizes for the rejection criteria for ultrasonic scanning, or equivalent shall be smaller than the maximum allowable defect sizes. For type CNG-2 and CNG-3 designs assume that there shall be no damage to composite due to any time-dependent mechanisms; the allowable defect size for NDE shall be determined by an appropriate method. ~~Two such methods are such as that~~ outlined in the informative Appendix F to this annex.

Reduced to only one method (performance test), by eliminating the calculation approach, since the accuracy of the calculation approach could not be verified by the Type Approval Authorities.

6.17. Change of design

Table 6.1

Material design qualification test

	<i>Relevant paragraph of this annex</i>				
	<i>Steel</i>	<i>Aluminium</i>	<i>Resins</i>	<i>Fibres</i>	<i>Plastic liners</i>
Tensile properties	6.3.2.2.	6.3.3.4.		6.3.5.	6.3.6.
Impact properties	6.3.2.3.				
Bending properties	6.3.2.4.				
Weld examination	6.3.2.5.				
Sulphide stress cracking resistance	6.3.2.6.				
Sustained load crack resistance		6.3.3.3.			
Stress corrosion cracking		6.3.3.2.			
Shear strength			6.3.4.2.		
Glass transition temperature			6.3.4.3.		
Softening/melting temperature					6.3.6.
Fracture mechanics*	6.7.	6.7.			

~~*Not required if flawed cylinder test approach in paragraph A.7. of Appendix A to this annex is used~~

Bend properties and weld examinations have been eliminated as welding no longer a part of the Regulation. The Fracture mechanics have been removed from ISO 11439 as it has not been possible for Type Approval Authorities to verify the accuracy of calculations.

Table 6.4

Cylinder design qualification tests

Test and annex reference	Cylinder type			
	CNG-1	CNG-2	CNG-3	CNG-4
A.12. Burst	X *	X	X	X
A.13. Ambient temperature/cycle	X *	X	X	X
A.14. Acid environment test Environmental		X	X	X
A.15. Bonfire		X	X	X
A.16. Penetration	X	X	X	X
A.17. Flaw tolerance	X	X	X	X
A.18. High temperature creep		X	X	X
A.19. Stress rupture		X	X	X
A.20. Drop test			X	X
A.21. Permeation				X
A.24. PRD performance		X	X	X
A.25. Boss torque test	X			X
A.27. Natural gas cycling				X
A.6. LBB assessment		X	X	
A.7. Extreme temperature/cycle	X	X	X	X

X = required

* = Not required for cylinders designed to ISO 9809 (ISO 9809 already provides for these tests).

The name of the A.14 test has been changed as it has now been replaced by the Environmental test moved from Annex H.

The A.24 PRD performance test has been replaced by referencing the use of the comprehensive performance tests for PRDs in the ISO 15500-13 standard.

Table 6.7
Change of design

Design change	Type of test								
	Burst Hydrostatic A.12	Cycling ambient temp: A.13	Environm. A.14	Bonfire A.15	Penetration A.16	Flaw tolerance A.17	High temp: Creep A.18 Stress rupture A.19 Drop test A.20	Permeation A.21 CNG Boss torque A.25 Cycling A.27	PRD performance A.24
Fibre manufacturer	X	X					X*	X†	
Metallic cylinder or liner material	X	X	X*	X	X*	X	X*		
Plastic liner material		X	X					X†	
Fibre material	X	X	X	X	X	X	X	X†	
Resin material			X		X	X	X		
Diameter change ≤ 20 per cent	X	X							
Diameter change > 20 per cent	X	X		X	X*	X			
Length change ≤ 50 per cent	X			X†					
Length change > 50 per cent	X	X		X†					
Working pressure change ≤ 20 per cent [@]	X	X							
Dome shape	X	X						X†	
Opening size	X	X							
Coating change			X						
End boss design								X†	
Change in manuf process	X	X							
Pressure relief device				X					X

X = required

* Test not required on metal (CNG-1) designs:

† Test only required on all-composite (CNG-4) designs

‡ Test only required when length increases

@ Only when thickness changes proportional to diameter and/or pressure change.

Change of design table replaced by revised table below.

Table 6.7
Change of Design

Design change	Type of test												
	Permeation	CNG cycling	Hydrostatic burst	LBB	Pressure cycle at ambient	Bonfire	Penetration	Environmental	Flaw tolerance	High temp creep	Stress rupture	Drop Test	Boss Torque
	A.21	A.27	A.12	A.6	A.13	A.15	A.16	A.14	A.17	A.18	A.19	A.20	A.25
Fibre manufacturer			X		X						X	X	
Metal liner material (g)			X	X	X	X	X	X	X	X	X	X (h)	
Plastic liner material	X	X	X			X				X		X	X
Fibre material			X	X	X	X	X	X	X	X	X	X	
Resin material				X			X	X	X	X			
Diameter change $\leq 20\%$			X		X		X (e)						
Diameter change $> 20\%$ (b)			X	X	X	X	X		X			X (i)	
Length change $\leq 50\%$			X			X (a)							
Length change $> 50\%$			X		X	X (a)						X (i)	
Metal cylinder material (g)			X	X	X	X	X						
Working pressure change $\leq 20\%$			X		X								
Dome shape			X	X (f)	X								
Opening size			X (j)	X (l)	X (j)								
Coating change								X (j)					
End boss design (k)	X (c)	X (c)											X (d)
Pressure relief device						X							
Thread													X

^a Test only required when length increases.
^b Only when thickness change proportional to diameter and/or pressure change.
^c Only if boss/liner interface is affected.
^d Only if boss/liner or boss composite interface is affected or torque requirements change.
^e Only required if diameter decreases.
^f For CNG-1 and CNG-2 designs only, except for ISO 9809-1 designs
^g Materials tests are also required
^h For CNG-3 designs only
ⁱ For CNG-3 and CNG-4 designs only
^j For CNG-2, CNG-3 and CNG-4 designs only
^k For CNG-4 designs only

The revised table has been expanded to provide a wider range of “change of design” conditions that qualify for the use of reduced test requirements. The added conditions are:

- Metal cylinder material – for a change of alloy type
- Thread – when the thread pitch or type on the port has changed.

The "Change in Manufacturing Process" was removed, as it is believed that if the manufacturing process changes in any way, then it is a new cylinder design and must undergo full qualification testing.

The revised table also includes the following added tests:

- *Leak-before-Break (LBB) test*
- *Stress Rupture test*
- *Drop test*

The "PRD performance" test (A.24) was removed, as PRD designs must be separately qualified in accordance with ISO 15500-13.

7. Type CNG-1 metal cylinders

7.1. General

The design shall identify the maximum size of an allowable defect at any point in the cylinder which will not grow to a critical size within the specified retest period, or service life if no retest is specified, of a cylinder operating to the working pressure. Determination of leak-before-break (LBB) performance shall be done in accordance with the appropriate procedures defined in paragraph A.6. (Appendix A to this annex). Allowable defect size shall be determined in accordance with paragraph 6.15.2. above. ~~Cylinders designed in accordance with ISO 9809 and meeting all the requirements therein are only required to meet the materials test requirements of paragraph 6.3.2.4. above and the design qualification test requirements of paragraph 7.5., except paragraphs 7.5.2. and 7.5.3. below.~~

It was stated that ISO 9809 designs are acceptable for CNG service, provided they meet the materials and design test requirements in ISO 11439. Instead, it has been decided that the preferred approach is to give ISO 9809 designs exemptions from certain tests in ISO 11439. These exemptions are provided in clause 7.4 of the Regulation.

7.3. Manufacturing and production test requirements

7.3.2. Non-destructive examination

The following tests shall be carried out on each metallic cylinder:

- (a) Hardness test in accordance with paragraph A.8. (Appendix A to this annex);
- (b) Ultrasonic examination, in accordance with **ISO 9809-1, Annex B**, ~~BS 5045, Part 1, Annex I~~, or demonstrated equivalent NDT method, to ensure that the maximum defect size does not exceed the size specified in the design as determined in accordance with paragraph 6.15.2. above.

BS standard replaced with equivalent ISO standard.

7.4. Cylinder batch tests

Batch testing shall be conducted on finished cylinders which are representative of normal production and are complete with identification marks. Two cylinders shall be randomly selected from each batch. If more cylinders are subjected to the tests than are required by this annex, all results shall be documented. **Cylinders qualified in accordance with ISO 9809-1, ISO 9809-2, ISO 9809-3 or ISO**

7866 are not required to perform the pressure cycling test described in paragraph A.13. (Appendix A to this annex). The following tests shall as a minimum be carried out on these:

Cylinders designed to these 4 ISO standards provide pressure cycle lives that exceed the CNG cylinder service cycle test requirements in A.13, so they are exempted from this one test.

(c) Periodic pressure cycling test. Finished cylinders shall be pressure cycled in accordance with paragraph A.13. (Appendix A to this annex) at a test frequency defined as follows:

(iv) Should more than 6 months have expired since the last batch of production, then a cylinder from the next batch of production shall be pressure cycle tested in order to maintain the reduced frequency of batch testing in (ii) or (iii) above.

Editorial.

8. Type CNG-2 hoop-wrapped cylinders

8.3.3.1. Curing of thermosetting resins

If a thermosetting resin is used, the resin shall be cured after filament winding. During the curing, the curing cycle (i.e. the time-temperature history) shall be documented. The curing temperature shall be controlled and shall not affect the material properties of the liner. The maximum curing temperature for cylinders with aluminium liners **shall be below the time and temperature that adversely affect metal properties** is ~~177°C~~.

Eliminated the use of a specific temperature limit for curing when aluminium liners are involved, as different aluminium alloys will have different temperature limits.

8.4.1. Non-destructive examination

Non-destructive examinations shall be carried out in accordance with a recognized ISO or an equivalent standard. The following tests shall be carried out on each metallic liner:

- (a) Hardness test in accordance with paragraph A.8. (Appendix A to this annex);
- (b) Ultrasonic examination, in accordance with **ISO 9809-1, Annex B** ~~BS 5045, Part 1~~, or demonstrated equivalent NDT method, to ensure that the maximum defect size does not exceed the size specified in the design.

BS standard replaced with equivalent ISO standard.

8.6. Cylinder design qualification tests

8.6.4. ~~Acid environment~~ **Environmental** test

One cylinder shall be tested in accordance with paragraph A.14. (Appendix A to this annex) and meet the requirements therein. ~~An optional environmental test is included in the informative Appendix H to this annex.~~

The Environmental test in Annex H has replaced the Acid environment test that was in the Regulation. The Environmental test is a far more comprehensive test of road environments compared to the Acid environment test that is currently in the Regulation. The Environmental test was developed by the automotive industry due to ruptures of glass reinforced composite cylinders in CNG service by stress corrosion cracking.

8.6.8. High temperature creep test

In designs where the glass transition temperature of the resin does not exceed ~~the maximum design material temperature by at least 20~~ 102°C, one cylinder shall be tested in accordance with paragraph A.18. (Appendix A to this annex) and meet the requirements therein.

In ISO 11439 an absolute minimum temperature of 102°C has been established, because otherwise the maximum design material temperature could be established by the manufacturer at a relatively low temperature, with the result that it would be too easy to claim the glass transition temperature is exceeded by 20°C.

10. Type CNG-4 all-composite cylinders

10.4. Manufacturing requirements

Manufacturing requirements shall be in accordance with paragraph 8.3. above ~~except that the curing temperature for thermosetting resins shall be at least 10 °C below the softening temperature of the plastic liner.~~

The requirement for the resin curing temperature to be less than the plastic softening temperature was eliminated, because if the curing temperature did affect the plastic liner integrity, then the hydrostatic proof test (required on every cylinder) would detect this problem.

10.6. Cylinder batch tests

10.6.1. General

(a) Batch materials test

(iii) The ~~softening melt~~ softening temperature of the plastic liner shall be tested in accordance with paragraph A.23. (Appendix A to this annex), and meet the requirements of the design;

The softening temperature is determined by ISO 306 “Plastics -- Thermoplastic materials -- Determination of Vicat softening temperature (VST)”. There is no standard for determining the melt temperature - in polymers, a sharp melting point usually does not occur; instead a melting temperature range is observed on heating.

Annex 3A - Appendix A

Test methods

A.1. Tensile tests, steel and aluminium

A tensile test shall be carried out on the material taken from the cylindrical part of the finished cylinder using a rectangular test piece shaped in accordance with the method described in ISO 9809 for steel and ISO 7866 for aluminium. ~~For cylinders with welded stainless steel liners, tensile tests shall be also carried out on material taken from the welds in accordance with the method described in paragraph 8.4. of EN 13322-2.~~ The two faces of the test pieces representing the inside and outside surface of the cylinder shall not be machined. The tensile test shall be carried out in accordance with ISO 6892-1.

The use of welded materials has already been removed from this Regulation.

A.2. Impact test, steel cylinders and steel liners

The impact test shall be carried out on the material taken from the cylindrical part of the finished cylinder on three test pieces in accordance with ISO 148-1. The impact test pieces shall be taken in

the direction as required in Table 6.2 of Annex 3A from the wall of the cylinder. ~~For cylinders with welded stainless steel liners, impact tests shall be also carried out on material taken from the weld in accordance with the method described in paragraph 8.6. of EN 13322-2.~~ The notch shall be perpendicular to the face of the cylinder wall. For longitudinal tests the test piece shall be machined all over (on six faces), if the wall thickness does not permit a final test piece width of 10 mm, the width shall be as near as practicable to the nominal thickness of the cylinder wall. The test pieces taken in transverse direction shall be machined on four faces only, the inner and outer face of the cylinder wall unmachined.

The use of welded materials has already been removed from this Regulation.

A.6. Leak-Before-Break (LBB) performance test

Three finished cylinders shall be pressure cycled between not more than 2 MPa and ~~not less than 1.5 times working pressure 30 MPa~~ at a rate not to exceed 10 cycles per minute. All cylinders shall fail by leakage.

Changed to 1,5 times working pressure, to recognize the fact that other working pressures may be used.

A.7. Extreme temperature pressure cycling

(b) Hydrostatically pressurized for 500 cycles times the specified service life in years between not more than 2 MPa and not less than **1.3 times working pressure 26 MPa** at 65 °C or higher and 95 per cent humidity;

Changed to “1,3 times working pressure”, to recognize the fact that other working pressures may be used.

(d) Then pressurize from not more than 2 MPa to not less than **working pressure 20 MPa** for 500 cycles times the specified service life in years at -40 °C or lower;

Changed to “working pressure”, to recognize the fact that other working pressures may be used.

A.9.1. Coating performance tests

Coatings shall be evaluated using the following test methods, or using equivalent national standards.

(a) Adhesion testing in accordance with **ASTM D3359, ISO 4624** using Method A or B as applicable. The coating shall exhibit an adhesion rating of either 4A or 4B, as applicable;

ISO 4624 was erroneously introduced as an ISO test method equivalent to ASTM D3359 – it was found to not be equivalent, so the original use of ASTM D3359 has been returned.

(c) Impact resistance in accordance with ASTM D2794 ~~Test method for Resistance of Organic Coatings to the Effects of Rapid Deformation (Impact)~~. The coating at room temperature shall pass a forward impact test of 18 J (160 in-lbs);

Editorial.

(d) Chemical resistance when tested in general accordance with ASTM D1308 ~~Effect of Household Chemicals on Clear and Pigmented Organic Finishes~~. The tests shall be conducted using the Open Spot Test Method and 100 hour exposure to a 30 per cent sulfuric acid solution (battery acid with a specific gravity of 1.219) and 24 hours exposure to a polyalkalene glycol (e.g. brake fluid). There shall be no evidence of lifting, blistering or softening of the coating. The adhesion shall meet a rating of 3 when tested in accordance with ASTM D3359;

Editorial.

(e) Minimum 1,000 hours exposure in accordance with ~~ASTM G15453 Practice for Operating Light and Water Exposure Apparatus (Fluorescent W-Condensation Type) for Exposure of non-metallic Materials~~. There shall be no evidence of blistering, and adhesion shall meet a rating of 3 when tested in accordance with ~~ASTM D3359~~ ISO 4624. The maximum gloss loss allowed is 20 per cent;

ASTM replaced G53 with G154.

(f) Minimum 500 hours exposure in accordance with ~~ISO 9227 ASTM B117 Test Method of Salt Spray (Fog) Testing~~. Undercutting shall not exceed ~~2~~ 3 mm at the scribe mark, there shall be no evidence of blistering, and adhesion shall meet a rating of 3 when tested in accordance with ASTM D3359;

ISO equivalent of ASTM standard.

(g) Resistance to chipping at room temperature using ~~the ASTM D3170 Chipping Resistance of Coatings~~. The coating shall have a rating of 7A or better and there shall not be any exposure of the substrate.

Editorial.

A.9.2. Coating batch tests

(b) Coating adhesion

The coating adhesion strength shall be measured in accordance with ~~ASTM 3359~~ISO 4624, and shall have a minimum rating of 4 when measured using either Test Method A or B, as appropriate.

ISO 4624 was erroneously introduced as an ISO test method equivalent to ASTM D3359 – the original use of ASTM D3359 has therefore been returned.

A.10. Leak test

Type CNG-4 designs shall be leak tested using the following procedure (or an acceptable alternative);

(b) Any leakage ~~detected measured at any point that exceeds 0.004 standard cm³/hr~~ shall be cause for rejection. **Leakage is the release of gas through a crack, pore, un-bond or similar defect. Permeation through the wall in conformance to A.21 is not considered to be leakage.**

The value specified for excessive leakage could not be readily be measured, so it was left up to the approval agencies to determine the amount of leakage depending on the technique that was used. It was also clarified that permeated gas did not constitute leakage.

A.12. Hydrostatic pressure burst test

(a) The rate of pressurisation shall not exceed 1.4 MPa per second (~~200 psi/second~~) at pressures in excess of 80 per cent of the design burst pressure. If the rate of pressurisation at pressures in excess of 80 per cent of the design burst pressure exceeds 350 kPa/second (~~50 psi/second~~), then either the cylinder shall be placed schematically between the pressure source and the pressure measurement device, or there shall be a 5 second hold at the minimum design burst pressure;

Editorial.

(b) The minimum required (calculated) burst pressure shall be at least **the minimum burst pressure specified for the design** ~~45 MPa~~, and in no case less than the value necessary to meet the stress ratio requirements. Actual burst pressure shall be recorded. Rupture may occur in either the cylindrical region or the dome region of the cylinder.

Changed 45 MPa to “minimum burst pressure specified for the design”, to recognize the fact that different designs may have different burst pressures.

A.13. Ambient temperature pressure cycling

(b) Cycle the pressure in the cylinder between not more than 2 MPa and not less than **1,3 times working pressure** ~~26 MPa~~ at a rate not to exceed 10 cycles per minute.

Changed to 1,3 times working pressure, to recognize the fact that other working pressures may be used.

A.14. ~~Acid~~ **Environmental** test

~~On a finished cylinder the following test procedure should be applied:~~

~~(a) Exposing a 150 mm diameter area on the cylinder surface for 100 hours to a 30 per cent sulfuric acid solution (battery acid with a specific gravity of 1.219) while the cylinder is held at 26 MPa;~~

~~(b) The cylinder shall then be burst in accordance with the procedure defined in paragraph A.12. above and provide a burst pressure that exceeds 85 per cent of the minimum design burst pressure.~~

(replace with the Environmental test in Appendix H of Annex 3A)

The Environmental test in Annex H is far more comprehensive test of road environments compared to the Acid environment test that is currently in the Regulation. The Environmental test was developed by the automotive industry due to ruptures of glass reinforced composite cylinders in CNG service by stress corrosion cracking.

A.15. Bonfire test

A.15.5. General test requirements

Cylinders shall be pressurized with natural gas and tested in the horizontal position at both:

(a) Working pressure;

(b) 25 per cent of the working pressure (**only if a thermally-activated pressure relief device is not part of the design**).

Testing at 25% of working pressure is not required when a thermally-activated pressure relief device is used, as they function independently from the pressure in the cylinder.

A.16. Penetration tests

A cylinder pressurised to ~~20 MPa~~ **working pressure** ± 1 MPa with compressed gas shall be penetrated by an armour piercing bullet with a diameter of 7,62 mm or greater. The bullet shall completely penetrate at least one side wall of the cylinder. **For type CNG-1 designs, the projectile shall impact the side wall at 90°.** For type CNG-2, CNG-3 and CNG-4 designs, the projectile shall impact the side wall at an approximate angle of 45°. The cylinder shall reveal no evidence of fragmentation failure. Loss of small pieces of material, each not weighing more than 45 grams, shall not constitute failure of the test. The approximate size of entrance and exit openings and their locations shall be recorded.

Changed 20 MPa to “working pressure”, to recognize the fact that other working pressures may be used.

Changed impact angle for Type CNG-1 designs to 90 degrees (perpendicular), as it was found that armour-piercing bullets will ricochet when impacting steel cylinders at 45 degree angle.

A.17. Composite flaw tolerance tests

For type CNG-2, CNG-3 and CNG-4 designs only, one finished cylinder, complete with protective coating, shall have flaws in the longitudinal direction cut into the composite. The flaws shall be greater than the visual inspection limits as specified by the manufacturer. **As a minimum, one flaw shall be 25 mm long and 1.25 mm in depth, and another flaw shall be 200 mm long and 0.75 mm in depth, cut in the longitudinal direction into the cylinder sidewall.**

The flawed cylinder shall then be pressure cycled from not more than 2 MPa to not less than ~~26 MPa~~ **1.3 times working pressure** for 3,000 cycles, ~~followed by an additional 12,000 cycles at ambient temperature;~~ The cylinder shall not leak or rupture within the first 3,000 cycles, but may fail by leakage during the ~~last 12,000~~ **further design lifetime in years × 1 000 cycles (less the 3 000 cycles already performed)**, ~~cycles~~. All cylinders which complete this test shall be destroyed.

Changed to 1,3 times working pressure, to recognize the fact that other working pressures may be used.

Replaced the “12,000 cycles” as this value would then limit the design lifetime to 15 years, while the number of cycles should be a function of the lifetime of the design, which may not be 15 years.

A.18. High temperature creep test

(a) The cylinder shall be pressurised to ~~26 MPa~~ **1.3 times working pressure** and held at a temperature of 100 °C for not less than 200 hours;

Changed to 1,3 times working pressure, to recognize the fact that other working pressures may be used.

(b) Following the test, the cylinder shall meet the requirements of the hydrostatic expansion test A.11., the leak test A.10. (**for Type CNG-4 cylinders only**), and the burst test A.12. above.

Clarification that the Leak test only applies to Type 4 designs.

A.19. Accelerated stress rupture test

For type CNG-2, CNG-3, and CNG-4 designs only, one cylinder free of protective coating shall be hydrostatically pressurised to ~~26 MPa~~ **1.3 times working pressure** while immersed in water at 65 °C. The cylinder shall be held at this pressure and temperature for 1,000 hours. The cylinder shall then be pressured to burst in accordance with the procedure defined in paragraph A.12. above except that the burst pressure shall exceed 85 per cent of the minimum design burst pressure.

Changed to 1,3 times working pressure, to recognize the fact that other working pressures may be used.

A.20. Impact damage test

One or more finished cylinders shall be drop tested at ambient temperature without internal pressurisation or attached valves. The surface onto which the cylinders are dropped shall be a smooth, horizontal concrete pad or flooring. One cylinder shall be dropped in a horizontal position with the bottom 1.8 m above the surface onto which it is dropped. One cylinder shall be dropped vertically on each end at a sufficient height above the floor or pad so that the potential energy is 488 J, but in no

case shall the height of the lower end be greater than 1.8 m. One cylinder shall be dropped at a 45° angle onto a dome from a height such that the centre of gravity is at 1.8 m; however, if the lower end is closer to the ground than 0.6 m, the drop angle shall be changed to maintain a minimum height of 0.6 m and a centre of gravity of 1.8 m.

The cylinders shall be allowed to bounce on the concrete pad or flooring after the initial impact. No attempt shall be made to prevent this secondary impacting, but the cylinder may be prevented from toppling during the vertical drop tests.

Clarification regarding secondary impacts during drop tests. Secondary impacts are allowed during non-vertical tests, because that is a realistic result of an accidental drop.

Following the drop impact, the cylinders shall be pressure cycled ~~from not more than~~ **between 2 MPa to not less than 26 MPa and 1,3 times the working pressure at ambient temperature** for 1,000 cycles times the specified service life in years. The cylinders ~~may~~ **shall not** leak ~~or but not~~ rupture, **within the first 3 000 cycles, but may fail only by leakage during the further design lifetime in years x 1 000 cycles (less the 3 000 cycles already performed).** ~~during the cycling.~~ Any cylinders completing the cycling test shall be destroyed.

Changed from 26 MPa to “1,3 times working pressure” to allow use of other working pressures in CNG service.

A.21. Permeation test

This test is only required on type CNG-4 designs. One finished cylinder shall be filled with compressed natural gas ~~or a 90 per cent nitrogen/10 per cent helium mixture~~ to working pressure, placed in an enclosed sealed chamber at ambient temperature, and monitored for leakage for **up to 500 h, a time sufficient** to establish a steady state permeation rate. The permeation rate shall be less than 0.25 ml of natural gas ~~or helium~~ per hour per litre water capacity of the cylinder.

A nitrogen/helium mixture is not equivalent to the permeation rate associated with natural gas.

A minimum time of 500 hours was established to prevent prematurely assuming a steady-state value had been achieved. Often a “permeation breakthrough” (saturation of the plastic liner) occurs after some 200 hours, after which a steady state permeation rate can be established.

A.22. Tensile properties of plastics

The tensile yield strength and ultimate elongation of plastic liner material shall be determined at -50 °C using ISO ~~527-2 3628~~, and meet the requirements of paragraph 6.3.6. of Annex 3A.

ISO 3628 is for photography processing chemicals. The correct reference is ISO 527-2 Plastics -- Determination of tensile properties -- Part 2: Test conditions for moulding and extrusion plastics

A.23. ~~Melting~~ **Softening** temperature of plastics

Polymeric materials from finished liners shall be tested in accordance with the method described in ISO 306, **The softening temperature shall be at least 100°C** ~~and meet the requirements of paragraph 6.3.6. of Annex 3A.~~

The ISO 306 standard “Plastics -- Thermoplastic materials -- Determination of Vicat softening temperature (VST)”, does not determine the melting point, so this value has been eliminated. The softening temperature was increased to the former melting point value in consideration of the higher temperatures that can be obtained in Type 4 cylinder designs during fast filling.

A.24. Pressure relief device requirements

Pressure relief devices **shall meet the requirements of ISO 15500-13**, specified by the manufacturer shall be shown to be compatible with the service conditions listed in paragraph 4. of Annex 3A and through the following qualification tests:

(a) ~~One specimen shall be held at a controlled temperature of not less than 95 °C and a pressure not less than test pressure (30 MPa) for 24 hours. At the end of this test there shall be no leakage or visible sign of extrusion of any fusible metal used in the design.~~

(b) One specimen shall be fatigue tested at a pressure cycling rate not to exceed 4 cycles per minute as follows:

(i) ~~Held at 82 °C while pressured for 10,000 cycles between 2 MPa and 26 MPa;~~

(ii) ~~Held at 40 °C while pressure for 10,000 cycles between 2 MPa and 20 MPa.~~

~~At the end of this test there shall be no leakage, or any visible sign of extrusion of any fusible metal used in the design.~~

(c) ~~Exposed brass pressure retaining components of pressure relief devices shall withstand, without stress corrosion cracking, a mercurous nitrate test as described in ASTM B154. The pressure relief device shall be immersed for 30 minutes in an aqueous mercurous nitrate solution containing 10 g of mercurous nitrate and 10 ml of nitric acid per litre of solution. Following the immersion, the pressure relief device shall be leak tested by applying an acrostatic pressure of 26 MPa for one minute during which time the component shall be checked for external leakage; Any leakage shall not exceed 200 cm³/h;~~

(d) ~~Exposed stainless steel pressure retaining components of pressure relief devices shall be made of an alloy type resistant to chloride induced stress corrosion cracking.~~

The A.24 PRD test has been replaced by referencing the use of the comprehensive PRD performance tests in the ISO 15500-13 standard.

A.25. Boss torque test

The body of the cylinder shall be restrained against rotation and ~~a torque of 500 Nm~~ **150% of manufacturers recommended torque** shall be applied to each end boss of the cylinder, first in the direction to tighten a threaded connection, then in the untightening direction, and in in the tightening direction.

The 500 Nm value was too arbitrary, and did not reflect the type of wrench connection that might be attached to a valve to turn it. As a result, a manufacturer's torque specification is necessary.

A.26. Resin shear strength

Resin materials shall be tested on a sample coupon representative of the composite over-wrap in accordance with ~~ISO 14130~~ **ASTM D2344**, or an equivalent national standard. Following a 24-hour water boil the composite shall have a minimum shear strength of 13,8 MPa.

ISO equivalent to ASTM standard.

A.27. Natural gas cycling test

One finished cylinder shall be pressure cycled using compressed natural gas from less than 2 MPa to working pressure for ~~300~~ **1 000** cycles. Each cycle, consisting of the filling and venting of the cylinder, shall not exceed 1 hour. The cylinder shall be leak tested in accordance with paragraph A.10. above and meet the requirements therein. Following the completion of the natural gas cycling the

cylinder shall be sectioned and the liner/end boss interface inspected for evidence of any deterioration, such as fatigue cracking or electrostatic discharge.

The number of CNG gas cycles was been increased to 1 000 in ISO 11439, to better indicate the lifetime service of a cylinder, and to better consider the combined long-term effects of stress, temperature, and permeation on the integrity of the plastic liner.

~~A.28. ——— Bend test, welded stainless steel liners~~

~~Bend tests shall be carried out on material taken from the cylindrical part of a welded stainless steel liner and tested in accordance with the method described in paragraph 8.5. of EN 13322-2. The test piece shall not crack when bent inwards around a former until the inside edges are not further apart than the diameter of the former.~~

Since welds are not permitted in the standard, there is no need for weld tests.

Annex 3A - Appendix F

Fracture performance methods

~~F.1. ——— Determination of fatigue sensitive sites~~

~~The location and orientation of fatigue failure in cylinders shall be determined by appropriate stress analysis or by full scale fatigue tests on finished cylinders as required under the design qualification tests for each type of design. If finite element stress analysis is used, the fatigue sensitive site shall be identified based on the location and orientation of the highest tensile principal stress concentration in the cylinder wall or liner at the working pressure.~~

~~F.2. ——— Leak Before Break (LBB)~~

~~F.2.1. — Engineering critical assessment. This analysis may be carried out to establish that the finished cylinder will leak in the event of a defect in the cylinder or liner growing into a through wall crack. A leak before break assessment shall be performed at the cylinder side wall. If the fatigue sensitive location is outside the side wall, a leak before break assessment shall also be performed at that location using a Level II approach as outlined in BS PD6493. The assessment shall include the following steps:~~

~~(a) Measure the maximum length (i.e. major axis) of the resultant through wall surface crack (usually elliptical in shape) from the three cylinder cycle tested under the design qualification tests (according to paragraphs A.13. and A.14. of Appendix A to this annex) for each type of design. Use the longest crack length of the three cylinders in the analysis. Model a semi-elliptical through wall crack with a major axis equal to twice the measured longest major axis and with a minor axis equal to 0.9 of wall thickness. The semi-elliptical crack shall be modelled at the locations specified in paragraph F.1. above. The crack shall be oriented such that the highest tensile principal stress shall drive the crack;~~

~~(b) Stress levels in the wall/liner at 26 MPa obtained from the stress analysis as outlined in paragraph 6.6. of Annex 3A shall be used for the assessment. Appropriate crack driving forces shall be calculated using either Section 9.2 or 9.3. of BS PD6493;~~

~~(c) Fracture toughness of the finished cylinder or the liner from a finished cylinder, as determined at room temperature for aluminium and at -40 °C for steel, shall be established using a standardized testing technique (either ISO/DIS 12737 or ASTM 813-89 or BS 7448) in accordance with Sections 8.4 and 8.5 of BS PD6493;~~

~~(d) Plastic collapse ratio shall be calculated in accordance with Section 9.4. of BS PD6493-91;~~

(e) The modelled flaw shall be acceptable in accordance with 11.2. of BS PD6493-91.

F.2.2. LBB by flawed cylinder burst

A fracture test shall be performed by the cylinder side wall. If the fatigue sensitive locations as determined in paragraph F.1. above is outside the side wall, the fracture test shall also be performed at that location. The test procedure is as follows:

(a) Determination of leak before break flaw length

The length of the LBB flaw at the fatigue sensitive site shall be twice the length of the maximum length measured of the resultant through wall surface crack from the three cylinders cycle tested to failure under the design qualification tests for each type of design;

(b) Cylinder flaws

For type CNG-1 designs having fatigue sensitive site in the cylindrical part in the axial direction, external flaws shall be machined longitudinally, approximately at mid-length of the cylindrical part of the cylinder. The flaws shall be located at minimum wall thickness of the midsection based on thickness measurements at four points around the cylinder. For type CNG-1 designs having fatigue sensitive site outside the cylindrical part, the LBB flaw shall be introduced at the internal surface of the cylinder along the fatigue sensitive orientation.

For type CNG-2 and CNG-3 designs the LBB flaw shall be introduced in the metal liner;

For flaws to be tested by monotonic pressure, the flaw cutter shall be approximately 12.5 mm thick with an angle of 45 °C and a tip radius of 0.25 mm maximum. The cutter diameter shall be 50 mm for cylinder with outside diameter less than 140 mm, and 65 to 80 mm for cylinders with outside diameter greater than 140 mm (a standard CVN cutter is recommended).

Note—The cutter should be sharpened regularly to assure tip radius meets specification. The depth of the flaw may be adjusted to obtain a leak by monotonic hydro pressurization. The crack shall not propagate by more than 10 per cent outside of the machined flaw measured on the external surface;

(c) Test procedure

The test shall be performed by monotonic pressurisation or cyclic pressurisation as described below:

(i) Monotonic pressurisation to burst

The cylinder shall be pressurised hydrostatically until pressure is released from the cylinder at the flaw location. The pressurisation shall be performed as described in paragraph A.12. (Appendix A to this annex);

(ii) Cyclic pressure

The test procedure shall be in accordance with the requirements of paragraph A.13. of Appendix A to this annex.

(d) Acceptance criteria for the flawed cylinder test

The cylinder passes the tests if the following conditions are met:

(i) For monotonic pressurisation burst test, the failed pressure shall be equal or greater than 26 MPa. For monotonic pressurised burst test, a total crack length measured on the external surface of 1.1 times the original machined length is allowed.

(ii) For cycle tested cylinders, fatigue crack growth beyond the original machined flaw length is allowed. However, the failure mode shall be a "leak". Propagation of the flaw by fatigue should occur over at least 90 per cent of the length of the original machined flaw.

~~Note~~—If these requirements are not fulfilled (failure occurs below 26 MPa, even and if the failure is a leak), a new test can be performed with a less deep flaw. Also, if rupture type failure occurs at a pressure greater than 26 MPa and flaw depth is shallow, a new test can be performed with a deeper flaw.

F.3. Defect size for non-destructive examination (NDE)

F.3.1. NDE Defect size by engineering critical assessment

Calculations shall be performed in accordance with British Standard (BS) PD 6493, Section 3, using the following steps:

- (a) ~~Fatigue cracks shall be modelled at the high stress location in the wall/liner as planar flaws;~~
- (b) ~~The applied stress range at the fatigue sensitive site, due to a pressure between 2 MPa and 20 MPa, shall be established from the stress analysis as outlined in paragraph F.1. of this appendix;~~
- (c) ~~The bending and membrane stress component may be used separately;~~
- (d) ~~The minimum number of pressure cycles is 15,000;~~
- (e) ~~The fatigue crack propagation data shall be determined in air in accordance with ASTM E647. The crack plane orientation shall be in the C-L direction (i.e., crack plane perpendicular to the circumferences and along the axis of the cylinder), as illustrated in ASTM E399. The rate shall be determined as an average of 3 specimen tests. Where specific fatigue crack propagation data are available for the material and service condition, they may be used in the assessment.~~
- (f) ~~The amount of crack growth in the thickness direction and in the length direction per pressures cycle shall be determined in accordance with the steps outlined in Section 14.2. of the BS PD 6493-91 standard by integrating the relationship between the rate of fatigue crack propagation, as established in e) above, and the range of crack driving force corresponding to the applied pressure cycle;~~
- (g) ~~Using the above steps, calculate the maximum allowable defect depth and length which shall not cause the failure of the cylinder during the design life due to either fatigue or rupture. The defect size for NDE shall be equal to or less than the calculated maximum allowable defect size for the design.~~

The calculation method was eliminated as there was no way to verify the accuracy of the calculations. Instead, the fracture performance was limited to the use of the LBB test in the standard, and the use of a performance test method for NDE defect size.

F.3.2. NDE Defect size by flawed cylinder cycling

For type CNG-1, CNG-2 and CNG-3 designs, three cylinders containing artificial defects that exceed the defect length and depth detection capability of the NDE inspection method required in paragraph 6.15. of Annex 3A, shall be pressure cycled to failure in accordance with the test method in paragraph A.13. (Appendix A to this annex). For type CNG-1 designs having a fatigue sensitive site in the cylindrical part, external flaws shall be introduced on the side wall. For type CNG-1 designs having the fatigue sensitive site outside the side wall, and for type CNG-2 and CNG-3 designs, internal flaws shall be introduced. Internal flaws may be machined prior to the heat treating and closing of the end of the cylinder.

The cylinders shall not leak or rupture in less than 15,000 cycles. The allowable defect size for NDE shall be equal to or less than the artificial flaw size at that location.

Annex 3A - Appendix H

Environmental test

H.1. Scope

~~The environmental test is intended to demonstrate that NGV cylinders can withstand exposure to the automotive underbody environment and occasional exposure to other fluids. This test was developed by the United States of America (USA) automotive industry in response to cylinder failures initiated by stress corrosion cracking of the composite wrap. This test is applicable to type CNG-2, CNG-3 and CNG-4 designs only.~~

The preamble about the development of the test is not needed in a standard. It is a test of composite reinforcement, and therefore is not applicable to Type CNG-1 (all-metal) designs (it has been shown elsewhere that the chemicals and exposure times involved have no effect on steel or aluminum alloys).

H.2. Summary of test method

~~A cylinder is first preconditioned by a combination of pendulum and gravel impacts to simulate potential underbody conditions. The cylinder is then subjected to a sequence of immersion in simulated road salt/acid rain, exposure to other fluids, and pressure cycles and high and low temperature exposures. At the conclusion of the test sequence the cylinder will be hydraulically pressured to destruction. The remaining residual burst strength of the cylinder shall be not less than 805 per cent of the minimum design burst strength.~~

The gravel impacts were eliminated as the pendulum impact alone was found to create more damage.

H.3. Cylinder set-up and preparation

The cylinder shall be tested in a condition representative of installed geometry including coating (if applicable), brackets and gaskets, and pressure fittings using the same sealing configuration (i.e. O-rings) as that used in service. Brackets may be painted or coated prior to installation in the immersion test if they are painted or coated prior to vehicle installation.

~~Cylinders will be tested horizontally and nominally divided along their horizontal centreline into "upper" and "lower" sections. The lower section of the cylinder will be alternatively immersed in road salt/acid rain environment and in heated or cooled air.~~

The immersion part of the test was eliminated in ISO 11439 as the concentrated exposures to the 5 chemicals would provide a more severe test condition.

The upper section will be divided into 5 distinct areas and marked for preconditioning and fluid exposure (see **Figure H.1**). The areas will be nominally 100 mm in diameter. The areas shall not overlap on the cylinder surface. While convenient for testing, the areas need not be oriented along a single line, but shall not overlap the immersed section of the cylinder.

Although preconditioning and fluid exposure is performed on the cylindrical section of the cylinder, all of the cylinder, including the domed sections, should be as resistant to the exposure environments as are the exposed areas.

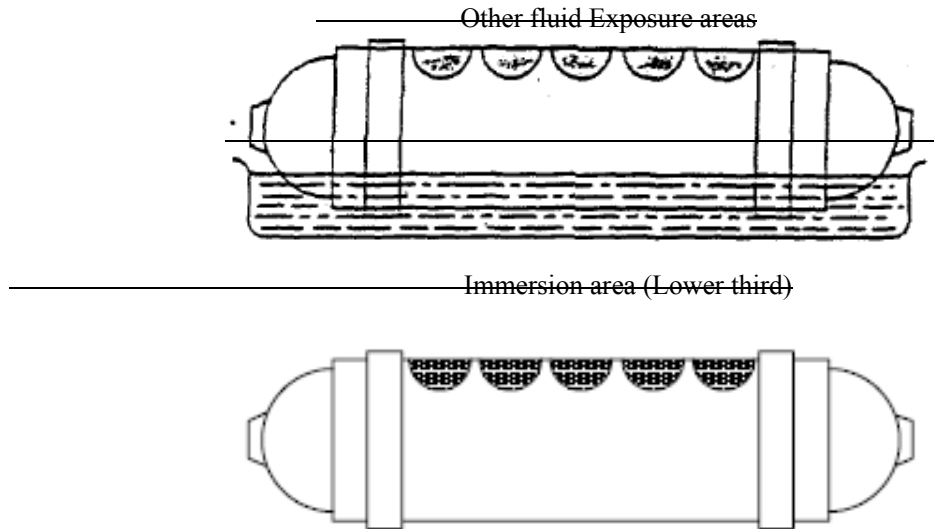

Figure H.1 - Cylinder orientation and layout of exposure areas

H.4. ~~Preconditioning apparatus~~ **Pendulum impact preconditioning**

The following apparatus are needed for preconditioning the test cylinder by pendulum and gravel impact:

(a) ~~Pendulum impact preconditioning~~

The impact body shall be of steel and have the shape of a pyramid with equilateral triangle faces and a square base, the summit and the edges being rounded to a radius of 3 mm. The centre of percussion of the pendulum shall coincide with the centre of gravity of the pyramid; its distance from the axis of rotation of the pendulum shall be 1 m. The total mass of the pendulum referred to its centre of percussion shall be 15 kg. The energy of the pendulum at the moment of impact shall be not less than 30 Nm and as close to that value as possible.

During pendulum impact, the cylinder shall be held in position by the end bosses or by the intended mounting brackets. **The cylinder shall be un-pressurized during preconditioning.**

Pressurization increases the resistance of the cylinder wall to impact damage. Thus the most susceptibility to damage is when the cylinder is un-pressurized during the pendulum impact.

(b) ~~Gravel impact~~

~~Machine constructed according to the design specifications shown in Figure H.2. This procedure for operation of the equipment shall follow that described in ASTM D3170, Standard Test Method for Chip Resistance of Coatings with the exception that the cylinder may be at ambient temperature during gravel impact;~~

(c) ~~Gravel~~

~~Alluvial road gravel passing through a 16 mm space screen but retained on a 9.5 mm space screen. Each application is to consist of 550 ml of graded gravel (approximately 250 to 300 stones);~~

Figure H.2

Gravel impact test

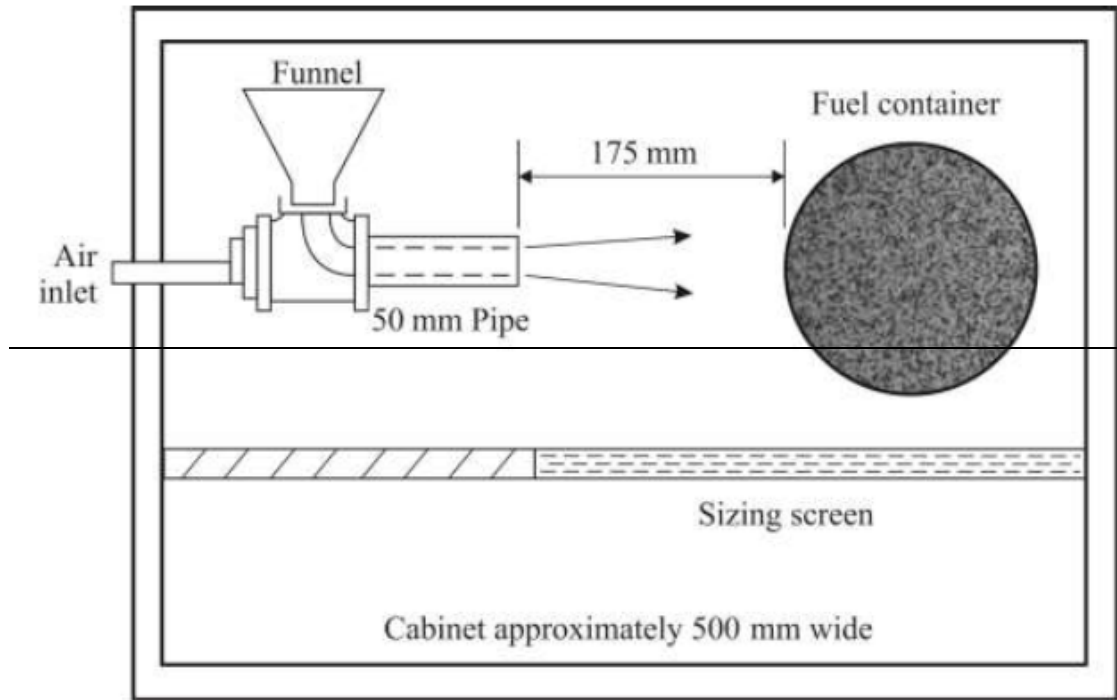

It was found in testing that the gravel impact had no apparent effect on the integrity of cylinders, or any protective coating – the pendulum impact was a much more severe test of a coating.

H.5. Environmental fluids for exposure environments

(a) Immersion environment

At the specified stage in the test sequence (Table 1) the cylinder will be oriented horizontally with the lower third of the cylinder diameter immersed in a simulated acid rain/road salt water solution. The solution will consist of the following compounds:

Deionized water;

Sodium chloride: 2.5 per cent by weight \pm 0.1 per cent;

Calcium chloride: 2.5 per cent by weight \pm 0.1 per cent;

Sulphuric acid: Sufficient to achieve a solution pH of 4.0 ± 0.2 ;

Solution level and pH are to be adjusted prior to each test step which uses this liquid. The temperature of the bath shall be 21 ± 5 °C. During immersion, the unsubmerged section of the cylinder shall be in ambient air.

The use of an “immersion environment” in the Environmental test was discarded as the use of concentrated chemicals was considered more severe.

(b) Other fluid exposure

~~At the appropriate stage in test sequence (Table 1) e~~Each marked area is to be exposed to one of five solutions for 30 minutes. The same environment shall be used for each location throughout the test. The solutions are:

Sulphuric acid: 19 per cent solution by volume in water;

Sodium hydroxide: 25 per cent solution by weight in water;

5% Methanol/95% gasoline: gasoline concentration of M5 fuel meeting the requirements of ASTM D4814 ~~30/70 per cent concentrations;~~

There was a need to define "gasoline", thus ASTM D4814 was added..

Ammonium nitrate: 28 per cent by weight in water;

Windshield washer fluid (**50%by volume solution of methyl alcohol and water**)

There was a need to define "windshield washer fluid".

When exposed, the test sample will be oriented with the exposure area uppermost. A pad of glass wool ~~one layer thick~~ (approximately 0.5 mm **thick**) and ~~trimmed to the appropriate dimensions between 90 and 100 mm in diameter shall~~ is to be placed on the exposure area. Using a pipet, apply 5 ml of the test fluid to the exposure area **Apply an amount of the test fluid to the glass wool sufficient to ensure that the pad is wetted evenly across its surface and through its thickness for the duration of the test, and that the concentration of the fluid is not changed significantly during the duration of the test.** ~~Remove the gauze pad after pressurization of the cylinder for 30 minutes.~~

There was a need to define how the chemicals were held onto the surface of the cylinder.

H.6. ~~Test conditions~~ **Pressure cycle and hold**

(a) ~~Pressure cycle~~

~~As defined in the test sequence,~~ **The cylinder shall be hydraulically pressure cycled between not less than 2 MPa and not more than 125% of working pressure 26 MPa for a total of 3 000 cycles. The maximum pressurization rate shall be 2.75 MPa per second. After pressure cycling, the cylinder shall be pressurized to 125% of working pressure and held at that pressure a minimum of 24 hours and until the elapsed exposure time (pressure cycling and pressure hold) to the environmental fluids equals 48 hours. The total cycle shall be not less than 66 seconds and will include a 60 second minimum hold at 26 MPa. The nominal cycle process will be:**

Ramp up from ≤ 20 MPa to ≥ 26 MPa;

Hold at ≥ 26 MPa for 60 seconds minimum;

Ramp down from ≥ 26 MPa to ≤ 2 MPa;

Total minimum cycle time to be 66 seconds.

(b) ~~Pressure during other fluid exposure~~

~~Following application of the other fluids, the cylinder shall be pressured to not less than 26 MPa for a minimum of 30 minutes;~~

(c) ~~High and low temperature exposure~~

As defined in the test sequence, the entire cylinder shall be exposed to high or low temperature air in contact with external surface. The low temperature air shall be $-40\text{ }^{\circ}\text{C}$ or lower and the high temperature air shall be $82\text{ }^{\circ}\text{C} \pm 5\text{ }^{\circ}\text{C}$. For the low temperature exposure, the fluid temperature of type CNG-1 cylinders shall be monitored using a thermocouple installed within the cylinder to ensure it remains at $-40\text{ }^{\circ}\text{C}$ or lower.

H.7. Test procedure

(a) Preconditioning of the cylinder

Each of the five areas marked for other fluid exposure on the upper section of the cylinder shall be reconditioned by a single impact of the pendulum body summit at their geometric centre. Following impact, the five areas shall be further conditioned by a gravel impact application. The central section of the bottom portion of the cylinder that will be submerged shall be preconditioned by an impact of the pendulum body summit at three locations spaced approximately 150 mm apart.

Following impact, the same central section that was impacted shall be further conditioned by a gravel impact application. The cylinder shall be unpressured during preconditioning.

(b) Test sequence and cycles

The sequence of the environment exposure, pressure cycles, and temperature to be used are defined in Table 1.

The cylinder surface is not to be washed or wiped between stages.

H.8. Acceptable results

Following the above test sequence, the cylinder shall be hydraulically tested to destruction in accordance with the procedure in paragraph A.12. of Appendix A to this annex. The burst pressure of the cylinder shall be not less than 805 per cent of the minimum design burst pressure.

Table 1

Test conditions and sequence

<i>Test steps</i>	<i>Exposure environments</i>	<i>Number of pressure cycles</i>	<i>Temperature</i>
1	Other fluids	-	Ambient
2	Immersion	1,875	Ambient
3	Air	1,875	High
4	Other fluids	-	Ambient
5	Immersion	1,875	Ambient
6	Air	3,750	Low
7	Other fluids	-	Ambient
8	Immersion	1,875	Ambient
9	Air	1,875	High
10	Other fluids	-	Ambient
11	Immersion	1,875	Ambient