

Proposal for amendments to Regulation No. 55 (Mechanical couplings)

Submitted by the Chair of the informal group on Regulation No. 55

The text reproduced below was prepared by the experts of the informal group on UN Regulation No. 55 and introduces amendments on:

- (a) Applications in multi-vehicle combinations

The modifications to the existing text of the Regulation are marked in bold for new or strikethrough for deleted characters.

A. Proposal

Insert new §1.2.1.1. :

“1.2.1.1. For the purpose of this regulation a dolly is defined as a towing trailer especially designed to tow a semi-trailer.”

Amend §2.11. to read:

“2.11. The characteristic values D, D_c, S, V, ~~and U~~ **and A_v** are defined ~~or~~ **and determined-verified** as:”

Amend §2.11.1. to read:

“2.11.1. ~~The D or D_c value is the theoretical reference value for the horizontal forces in the towing vehicle and the trailer and is used as the basis for horizontal loads in the dynamic tests.~~

~~For mechanical coupling devices and components not designed to support imposed vertical loads, the value is:~~

$$\del D = g \frac{T \cdot R}{T + R} \text{ kN}$$

~~For mechanical coupling devices and components for centre axle trailers as defined in 2.13, the value is:~~

$$\del D_c = g \frac{T \cdot C}{T + C} \text{ kN}$$

~~For fifth wheel couplings of Class G, fifth wheel coupling pins of Class H and mounting plates of Class J, as defined in paragraph 2.6., the value is:~~

$$\del D = g \frac{0.6 \cdot T \cdot R}{T + R - U} \text{ kN}$$

~~Where:~~

~~T~~ — is the technically permissible maximum mass of the towing vehicle, in tonnes. ~~Where relevant, this includes the vertical load imposed by a centre axle trailer.¹~~

~~R~~ — is the technically permissible maximum mass, in tonnes, of a trailer with drawbar free to move in a vertical plane, or of a semitrailer.²

~~C~~ — is the mass, in tonnes, transmitted to the ground by the axle or axles of the centre axle trailer, as defined in paragraph 2.13., when coupled to the towing vehicle and loaded to the technically permissible maximum mass.² ~~For Category O1 and O2 centre axle trailers³ the technically~~

¹ The mass T and R and the technically permissible maximum mass, may be greater than the permissible maximum mass prescribed by national legislation.

² See definitions in Regulation No. 13 annexed to the 1958 Agreement concerning the Adoption of Uniform Technical Prescriptions for Wheeled Vehicles, Equipment and Parts which can be Fitted

~~permissible maximum mass will be that declared by the manufacturer of the towing vehicle.~~

~~g~~ is the acceleration due to gravity (assumed to be 9.81 m/s²)

~~U~~ is as defined in paragraph 2.11.2.

~~S~~ is as defined in paragraph 2.11.3.

The D and D_c value are characteristic performance values for the horizontal forces of the coupling equipment verified as described in Annex 6 of this regulation.”

Amend §.2.11.2. to read:

“2.11.2. ~~The U value is the vertical mass, in tonnes, imposed on the fifth wheel coupling by the semitrailer of technically permissible maximum mass.²~~

The U value is a characteristic performance value for the vertically imposed mass, in tonnes, on the fifth wheel coupling. This performance value shall be verified as described in Annex 6 of this regulation.”

Amend §.2.11.3. to read:

“2.11.3. ~~The S value is the vertical mass, in kilograms, imposed on the coupling, under static conditions, by the centre axle trailer, as defined in paragraph 2.13., of technically permissible maximum mass.²~~

The S value is a characteristic performance value for the vertically imposed mass, in kilograms, to the coupling from a center axle trailer under static conditions. This performance value shall be verified as described in Annex 6 of this regulation.”

Amend §.2.11.4. to read:

“2.11.4. ~~The V value is the theoretical reference value of the amplitude of the vertical force imposed on the coupling by the centre axle trailer of technically permissible maximum mass greater than 3.5 tonnes. The V value is used as the basis for vertical forces in the dynamic tests.~~

$$\del V = \frac{a \cdot C \cdot X^2}{L^2} \text{ (See the Note below)}$$

~~Where:~~

~~a~~ is an equivalent vertical acceleration at the coupling depending on the type of suspension system of the rear axle of the towing vehicle.

~~For air suspension (or suspension systems with equivalent damping characteristics)~~

$$\del a = 1.8 \text{ m/s}^2$$

and/or be Used on Wheeled Vehicles and the Conditions for Reciprocal Recognition of Approvals Granted on the Basis of these Prescriptions. The definition is also contained in the Consolidated Resolution on the Construction of Vehicles (R.E.3) (document TRANS/WP.29/78/Rev.3, para.2).

For other types of suspension:

$$a = 2.4 \text{ m/s}^2$$

X — is the length of the loading area of the trailer, in metres (see Figure 1)

L — is the distance from the centre of the drawbar eye to the centre of the axle assembly, in metres (see Figure 1)

Note: $\frac{X^2}{L^2} \geq 1.0$ (If less than 1.0, the value of 1.0 shall be used)

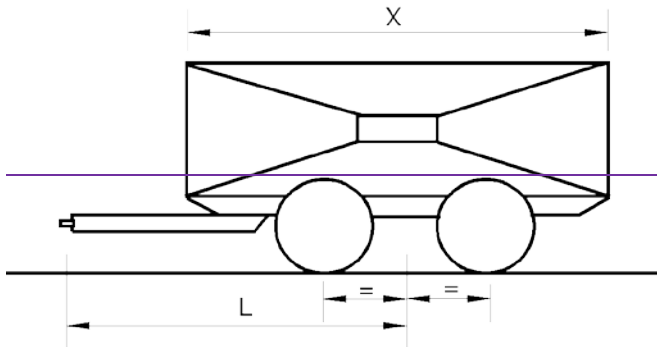

Figure 1
Dimensions of the centre axle trailer

The V value is a characteristic performance value of the amplitude of the vertical force imposed on the coupling by a center axle trailer. This performance value shall be verified as described in Annex 6 of this regulation.”

Insert new §.2.11.5. to read:

“2.11.5 The A_v value is a characteristic performance value for hinged drawbars that sets maximum permitted axle mass in tonnes of the front steered axle group of a full trailer. This performance value shall be verified as described in Annex 6 of this regulation.”

Insert new §.2.11.56. to read:

“2.11.56 To each of the characteristic performance value D, D_c , U, V and S there are corresponding application requirement values. Those requirements values are determined according to Annex 8 of this regulation.”

Amend §.2.12. to read:

“2.12. Symbols and definitions used in Annex 6 **and Annex 8** of this Regulation.

A_v = maximum permitted axle mass of the steered axle in tonnes – see **paragraph 2.11.5.**

C = mass of centre axle trailer in tonnes – see **Annex 8** paragraph **1.1.1. 2.11.1.** of this Regulation.

D = D-value in kN - see paragraph 2.11.1. of this Regulation.

- D_c = D_c -value in kN for centre axle trailers - see **Annex 8** paragraph **2.1. 2.11.1.** of this Regulation.
- R = mass of towed vehicle in tonnes - see **Annex 8** paragraph **2.1 2.11.1.** of this Regulation.
- T = mass of towing vehicle in tonnes - see **Annex 8** paragraph **2.1 2.11.1.** of this Regulation.
- F_a = static lifting force in kN.
- F_h = horizontal component of test force in longitudinal axis of vehicle in kN.
- F_s = vertical component of test force in kN.
- S = static vertical mass in kg. – **See paragraph 2.11.3. of this regulation.**
- U = fifth wheel imposed vertical mass in tonnes. – **See paragraph 2.11.2. of this regulation.**
- V = V -value in kN - see paragraph 2.11.4. of this Regulation.
- a = equivalent vertical acceleration factor at the coupling point of centre axle trailers depending on the type of suspension of the rear axle(s) of the towing vehicle - see **Annex 8** paragraph **2.2 2.11.1.** of this Regulation.
- ...”

Amend §5.3.45. to read:

“5.3.45. A statement of the **characteristic performance** values of D , D_c , S , V and U as applicable and as defined in paragraph 2.11.”

Amend §5.3.45.1. to read:

“5.3.45.1. The characteristic **performance** values shall be at least equal to those **requirement values** applicable to the maximum permissible towing vehicle, trailer and combination masses, **determined according to Annex 8 of this regulation.**”

Amend Annex 2 §7. to read:

“7. D kN D_c kN S kg
 U tonnes V kN

In case of a towing trailer performance of rear coupling equipment:

**D kN D_c kN S kg
 U tonnes V kN”**

Insert New Annex 8:

“Annex 8

Coupling performance requirements in application

1. Coupling equipment shall only be used in applications where calculated performance requirements do not exceed the performance capacity as determined in accordance with Annex 6 of this regulation. The following paragraphs of this annex state the way in which the performance requirements shall be calculated in different applications.
2. Two-vehicle combinations
- 2.1. Horizontal forces

For mechanical coupling devices and components not designed to support imposed vertical loads, the value is:

$$D = g \frac{T \cdot R}{T + R} \text{ kN}$$

For mechanical coupling devices and components for center axle trailers as defined in 2.13, the value is:

$$D_C = g \frac{T \cdot C}{T + C} \text{ kN}$$

For fifth wheel couplings of Class G, fifth wheel coupling pins of Class H and mounting plates of Class J, as defined in paragraph 2.6., the value is:

$$D = g \frac{0.6 \cdot T \cdot R}{T + R - U} \text{ kN}$$

where:

- T is the technically permissible maximum mass of the towing vehicle, in tonnes. Where relevant, this includes the vertical load imposed by a center axle trailer³.
- R is the technically permissible maximum mass, in tonnes, of a trailer with drawbar free to move in a vertical plane, or of a semitrailer³.
- C is the mass, in tonnes, transmitted to the ground by the axle or axles of the center axle trailer, as defined in paragraph 2.13., when coupled to the towing vehicle and loaded to the technically permissible maximum mass³. For Category O1 and O2 center axle trailers⁴ the technically permissible maximum mass will be that declared by the manufacturer of the towing vehicle.

³ The mass T and R and the technically permissible maximum mass, may be greater than the permissible maximum mass prescribed by national legislation.

⁴ See definitions in Regulation No. 13 annexed to the 1958 Agreement concerning the Adoption of Uniform Technical Prescriptions for Wheeled Vehicles, Equipment and Parts which can be Fitted and/or be Used on Wheeled Vehicles and the Conditions for Reciprocal Recognition of Approvals

Granted on the Basis of these Prescriptions. The definition is also contained in annex 7 of the Consolidated Resolution on the Construction of Vehicles (R.E.3) (document TRANS/WP.29/78/Rev.1/Amend.2).

2.2. Vertical forces from center axle trailer

The vertical force imposed on the coupling by the center axle trailer of technically permissible maximum mass greater than 3.5 tonnes is:

$$V = \frac{a \cdot C \cdot X^2}{L^2} \text{ kN} \quad (\text{See the Note below})$$

where:

C is as defined in paragraph 2.1. of this Annex

a is an equivalent vertical acceleration at the coupling depending on the type of suspension system of the rear axle of the towing vehicle.

For air suspension (or suspension systems with equivalent damping characteristics)

$$a = 1.8 \text{ m/s}^2$$

For other types of suspension:

$$a = 2.4 \text{ m/s}^2$$

X is the length of the loading area of the trailer, in meters (see Figure 27)

L is the distance from the center of the drawbar eye to the center of the axle assembly, in meters (see Figure 27)

Note: $\frac{X^2}{L^2} \geq 1.0$ (If less than 1.0, the value of 1.0 shall be used)

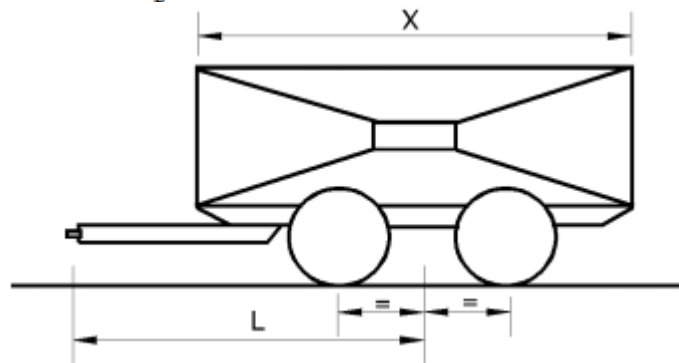

Figure 27
Dimensions of the center axle trailer

3. Multi-vehicle combinations

A general prerequisite for the application of the formulae below is that the stability of the combination is demonstrated.

3.1. Combination 1:

Description: Rigid truck + Dolly + Semitrailer

Masses [tonnes]:

M_1 = total axle load of rigid truck as coupled

M_2 = total axle load of dolly and semitrailer as coupled

M_3 = total axle load of dolly as coupled

M_4 = total axle load of rigid truck as coupled plus tare weight of dolly

M_5 = support load at king-pin of semitrailer

$M_6 = M_5 +$ total axle load of semitrailer as coupled

Total combination mass = $M_1 + M_2$

Dimensions:

L = distance from drawbar eye to center of dolly axle group [m]

Coupling capability requirement:

Clevis coupling: $D = g \frac{M_1 \cdot M_2}{M_1 + M_2} \quad V = \text{Max}(\frac{54}{L}; 5 \frac{M_3}{L})$

Fifth wheel: $D = 0.5g \frac{M_4(M_6 + 0.08M_4)}{M_4 + M_6 - M_5}$

3.2. Combination 2:

Description: Tractor + Semitrailer + center axle trailer

Masses [tonnes]:

M_1 = total axle load of tractor as coupled (including support load from semitrailer)

M_2 = total axle load of center axle trailer as coupled

M_3 = total axle load of tractor and semitrailer as coupled

M_4 = support load at king-pin of semitrailer

$M_5 = M_4 +$ total axle load of semitrailer and center axle trailer as coupled

Total combination mass = $M_2 + M_3$

Dimensions:

L = distance from drawbar eye to center of center axle trailer axle group [m]

X = length of loaded area of center axle trailer [m]

$a = 2.4$ [m/s²] for semitrailer with steel suspension; 1.8 [m/s²] for semitrailer with air suspension

Coupling capability requirement:

Clevis coupling on semitrailer: $D = 0.65g \frac{M_3 \cdot M_2}{M_3 + M_2} \quad V = a \frac{X^2}{L^2} M_2$

Fifth wheel: $D = 0.5g \frac{M_5(M_1 + 0.08M_5)}{M_1 + M_5 - M_4}$

3.3.

Combination 3:

Description: Tractor + Semitrailer + Dolly + Semitrailer

Masses [tonnes]:

M_1 = total axle load of tractor as coupled (including support load from first semitrailer)

M_2 = total axle load of tractor and first semitrailer as coupled

$M_3 = M_4$ + total axle load of second semitrailer as coupled

M_4 = total axle load of dolly as coupled (including support load from second semitrailer)

$M_5 = M_2$ + tare weight of dolly

M_6 = support load at king-pin of first semitrailer

M_7 = support load at king-pin of second semitrailer

$M_8 = M_7$ + total axle load of second semitrailer as coupled

$M_9 = M_6$ + total axle load of first semitrailer as coupled + M_3

Total combination mass = $M_2 + M_3$

Dimensions:

L = distance from drawbar eye to center of dolly axle group [m]

Coupling capability requirement:

Clevis coupling on first semitrailer:

$$D = 0.65g \frac{M_2 \cdot M_3}{M_2 + M_3}$$
$$V = \text{Max}\left(\frac{54}{L}; 5 \frac{M_4}{L}\right)$$

Fifth wheel:

$$D = \text{Max}(D_1; D_2)$$

$$D_1 = 0.5g \frac{M_5(M_8 + 0.08M_5)}{M_5 + M_8 - M_7}$$

$$D_2 = 0.5g \frac{M_9(M_1 + 0.08M_9)}{M_9 + M_1 - M_6}$$

3.4.

Combination 4:

Description: Rigid truck + center axle trailer + center axle trailer

Masses [tonnes]:

M_1 = total axle load of rigid truck as coupled

M_2 = total axle load of first center axle trailer as coupled

M_3 = total axle load of second center axle trailer as coupled

$M_4 = M_2 + M_3$

$M_5 = M_1 + M_2$

Total combination mass = $M_1 + M_2 + M_3$

Dimensions:

L_z = distance from drawbar eye to center of center axle trailer axle group [m]

X_z = length of loaded arc of center axle trailer [m]

T_1 = distance from center of axle group to coupling point of clevis coupling in rear end of first center axle trailer [m]

$a = 2.4$ [m/s²] for semitrailer with steel suspension; 1.8 [m/s²] for semitrailer with air suspension

Coupling capability requirement:

Clevis couplings:

$$D = 0.9g \frac{M_1 + M_4}{M_1 + M_4}$$

$$V = V_1$$

$$V_2 = a \frac{X_z^2}{L_z^2} M_3$$

$$V_1 = \sqrt{\left(a \frac{X_z^2}{L_z^2} M_2\right)^2 + \left(\frac{T_1^2}{L_1^2} V_2\right)^2}$$

3.5.

Combination 5:

Description: Tractor + Link-trailer* + Semitrailer

Masses [tonnes]:

M_1 = total axle load of tractor as coupled (including support load from link-trailer)

M_2 = support load at king-pin of link-trailer

M_3 = M_2 + total axle load of link-trailer and semitrailer as coupled

M_4 = total axle load of link-trailer and semitrailer as coupled

Total combination mass = $M_1 + M_4$

Coupling capability requirement:

Fifth wheel:

$$D = 0,5g \frac{M_3(M_1 + 0,08M_3)}{M_1 + M_3 - M_2}$$

* Link-trailer is a semitrailer equipped with a fifth wheel in its rear end enabling a second semitrailer to be towed.

B. Justification

The basic theme of the regulation 55 is to type approve a specific level of performance of coupling equipment and coupling installation. This could be done without knowing anything about the applications in which the coupling will be used. However the legislator has realized that just a certified performance does not say anything about the safety level. There need to exist a way to control to what extent that performance can be stressed.

Hence the current version of regulation 55 accounts for the application of coupling equipment in traditional vehicle combinations, i.e. rigid truck + full trailer, rigid truck + center axle trailer and tractor + semi-trailer.

Current transport systems use many different vehicle combinations that are not accounted for in regulation 55 e.g. rigid truck + dolly + semi-trailer. A number of countries in Europe apply modular vehicle combinations. Outside Europe combinations outside the traditional two vehicle combinations are applied in many places. Those “novel” combinations are with respect to coupling dimensioning handled in different ways in different countries. I.e. the level of safety is varying.

In order for the legislator to have control over a common safety level more applications need to be included in the regulation. The current version of the regulation has the traditional applications integrated in the specification of the performance certification. Including the “novel” applications in the same integrated way would risk making the regulation very hard to read and comprehend. Hence it is proposed to bring all application related text in to one new Annex. This clears the text relevant for performance certification from any application related statements. On the other hand the way to handle different applications becomes very clean and easy to find. The new annex also opens up an easy structure to handle any additional application related item appearing in the future.

The traditional applications are in the new Annex handled just the same as it has been handled hitherto. The applications introduced are the same as those in the ISO18868:2013 standard. The formulas used are also same as agreed in that standard. In turn this standard is based on Australian regulations used since the mid 1980:s. Before introducing those rules

the Australians made extensive measurements. The processing of the ISO18868:2013 standard within the ISO expert committee goes back to 2001. Hence it can be said that the formulae have been well scrutinized. During recent years many measurements of coupling forces in different vehicle combinations have been performed in Sweden. The results from those measurements have been compared to dimensioning using ISO18868:2013. The maximum forces registered from those measurements have all been found to be low in comparison to the dimensioning calculated using the formulae proposed. Hence we find the proposal well founded.