

Proposal for Supplement 7 to the 06 series of amendments to Regulation No. 16 (Safety-belts)

The text reproduced below was prepared by the expert from the European Association of Automotive Suppliers (CLEPA), to introduce provisions for a new fixture to verify space availability of universal lateral facing Child Restraint Systems (CRS) "lie-flat". It is based on a document without symbol (GRSP-57-07-Rev.1) distributed at the fifty-seventh session of the Working Party on Passive Safety (GRSP). The modifications to the current text of UN Regulation No. 16 are marked in bold for new or strikethrough for deleted characters.

It replaces document GRSP/2015/20

I. Proposal

Paragraph 8.3.6., amend to read:

"8.3.6. Any i-Size seating position shall allow the installation of the ISOFIX child restraint fixtures "ISO/F2X" (B1), "ISO/R2" (D), ~~"L1" (F) or "L2" (G)~~ and the support leg installation assessment volume as defined in Appendix 2 to Annex 17.

Any two adjacent i-Size seating positions shall allow the installation of the ISOFIX child restraint fixtures "L1" (F) or "L2" (G) and the support leg installation assessment volume as defined in Appendix 2 to Annex 17.

The support leg installation assessment volume ..."

Annex 17, Appendix 2,

Paragraph 4., amend to read:

"ISOFIX child restraint system size classes and fixtures

- A – ISO/F3: Full-Height Forward Facing toddler CRS
- B – ISO/F2: Reduced-Height Forward Facing toddler CRS
- B1– ISO/F2X: Reduced-Height Forward Facing toddler CRS
- C – ISO/R3: Full-Size Rearward Facing toddler CRS
- D – ISO/R2: Reduced-Size Rearward Facing toddler CRS
- E – ISO/R1: Rearward Facing infant CRS
- F – ~~ISO/~~ L1: Left Lateral Facing position CRS (carry-cot)
- G – ~~ISO/~~ L2: Right Lateral Facing position CRS (carry-cot)

The fixtures below shall be constructed with a mass between 5 and 15 kg and shall be of suitable durability and stiffness to satisfy the functional requirements.

Mass group	ISOFIX size class	Fixture (CRF)
0 – up to 10 kg	F	ISO/ L1
	G	ISO/ L2
	E	ISO/R1
0+ - up to 13 kg	C	ISO/R3

Mass group		ISOFIX size class	Fixture (CRF)
		D	ISO/R2
		E	ISO/R1
Section 1.02 kg	I - 9 to 18	A	ISO/F3
		B	ISO/F2
		B1	ISO/ F2X
		C	ISO/R3
		D	ISO/R2

"

Paragraph 4.7., amend to read:

"4.7. Lateral facing child restraint systems envelope

Figure 7

Envelope dimensions for lateral facing position CRS – ISO/L1- ISOFIX SIZE CLASS F or symmetrically opposite – ISO/L2 – ISOFIX CLASS G

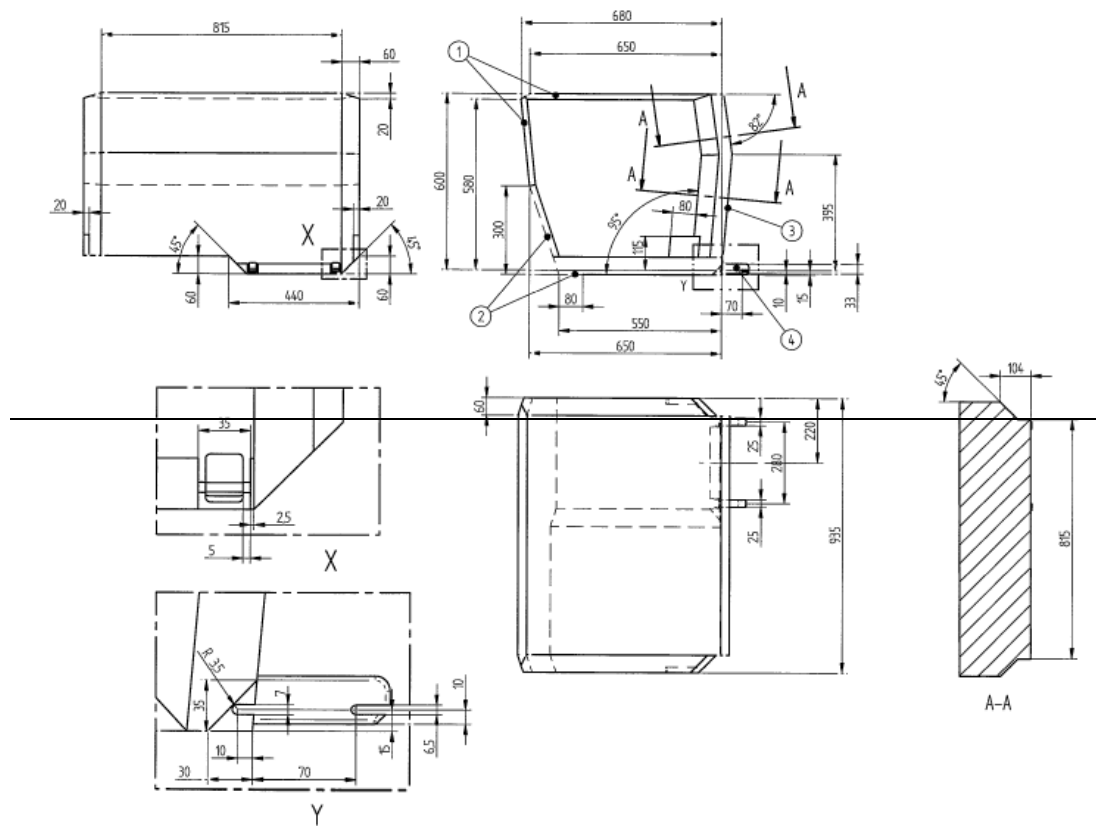

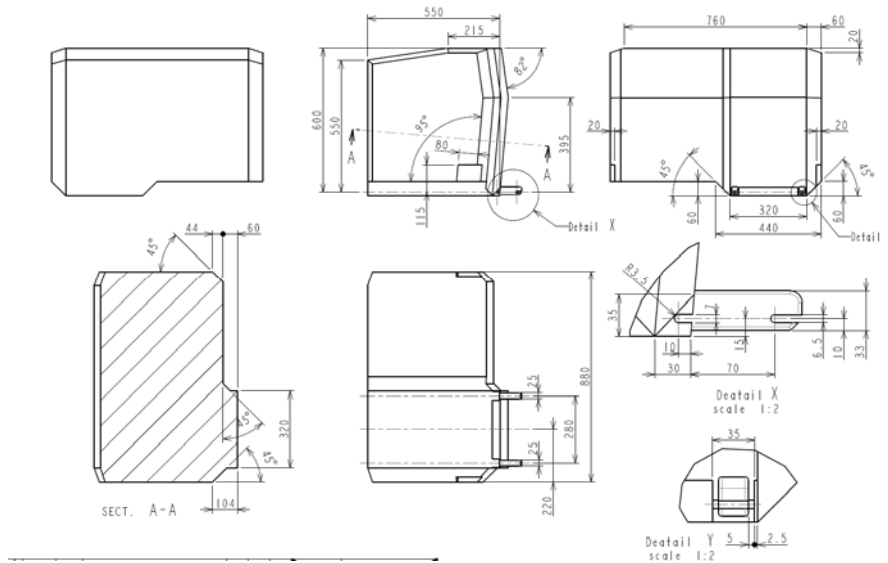

Key

- 1 Limits in the rearward and upwards directions
2. Dashed..."

Annex 17, Appendix 3, Table 2., amend to read:

"Table 2

Table of vehicle handbook information on ISOFIX child restraint systems installation and suitability for various ISOFIX positions

Mass Group	Size class	Fixture	Vehicle ISOFIX positions					
			Front passenger	Rear outboard	Rear centre	Intermediate outboard	Intermediate centre	Other sites
Carrycot	F	ISO/ L1						
	G	ISO/ L2						
0 – up to 10 Kg		(1)						
	E	ISO/R1						
0+ – up to 13 kg		(1)						
	E	ISO/R1						
	D	ISO/R2						
	C	ISO/R3						
		(1)						
	D	ISO/R2						

I – 9 to 18 kg	C	ISO/R3						
	B	ISO/F2						
	B1	ISO/F2X						
	A	ISO/F3						
		(1)						
I I – 15 to 25 kg		(1)						
III – 22 to 36 kg		(1)						

(1) = For the CRS which do not carry the ~~ISO/XX~~ size class identification (A to G), for the applicable mass group, the car manufacturer shall indicate the vehicle specific ISOFIX child restraint system(s) recommended for each position.

Key of letters to be inserted in the above table

IUF = Suitable for ISOFIX forward child restraints systems of universal category approved for use in the mass group

IL = Suitable for particular ISOFIX child restraint systems (CRS) given in the attached list. These ISOFIX CRS are those of the "specific vehicle", "restricted" or "semi-universal" categories.

X = ISOFIX position not suitable for ISOFIX child restraint systems in this mass group and/or this size class."

II. Justification

Completion of missing integral fixtures for UN Regulation No. 129 (ECRS). For further detailed explanation, see presentation GRSP-58-01.