

**Economic and Social Council**Distr.: General
3 July 2015

Original: English

Economic Commission for Europe

Inland Transport Committee

World Forum for Harmonization of Vehicle Regulations**Working Party on Brakes and Running Gear****Eightieth session**

Geneva, 15-18 September 2015

Item 4 of the provisional agenda

Regulation No. 55 (Mechanical couplings)**Proposal for Supplement 5 to the 01 series of amendments to
Regulation No. 55 (Mechanical couplings)****Submitted by the Chair of the informal group on Regulation No. 55***

The text reproduced below was prepared by the informal group of experts on Regulation No. 55 to introduce amendments on the test procedure and installation of couplings belonging to class K and L. The modifications to the current text of the Regulation are marked in bold for new or strikethrough for deleted characters.

* In accordance with the programme of work of the Inland Transport Committee for 2012–2016 (ECE/TRANS/224, para. 94 and ECE/TRANS/2012/12, programme activity 02.4), the World Forum will develop, harmonize and update Regulations in order to enhance the performance of vehicles. The present document is submitted in conformity with that mandate.

I. Proposal

Paragraph 4.7., amend to read:

"4.7. For devices and components of Class A, **Class K** or Class S, if applicable, for use with trailers of maximum permissible mass not exceeding 3.5 tons, and which are produced by manufacturers not having any association with the vehicle manufacturer and where the devices and components are intended for fitting in the after-market, the height and other installation features of the coupling shall, in all cases, be verified by the type approval authority or technical service in accordance with Annex 7, [paragraph 1]."

Paragraph 13., insert new numbers of subparagraphs 13.1. to 13.3.

"13.1. Until the United Nations Secretary-General such devices and components intended for vehicles of categories other than M1.

13.2. As from the official date of entry into force of [Supplement 5 to the 01 series of amendments], no Contracting Party applying this Regulation shall refuse to grant approval under this Regulation as amended by [Supplement 5 to the 01 series of amendments].

13.3. As from [12] months after the official date of entry into force of [Supplement 5 to the 01 series of amendments], Contracting Parties applying this Regulation shall grant new type approvals only if the devices, components and vehicle to be approved meets the requirements of this Regulation as amended by [Supplement 5 to the 01 series of amendments]."

Annex 4, Table 1 amend to read:

"Table 1 - Relevant characteristic values to be marked on coupling devices or components*

Description of mechanical coupling device or component	Relevant characteristic values to be marked					
	Class	D	Dc	S	U	V

* For coupling devices or components which belong to more than one class, the relevant characteristic values of each class shall be specified."

Paragraph 3.4.2., amend to read:

"3.4.2. Toroidal eyes of Class L shall be tested ~~in the same manner as standard drawbar eyes~~ as described in paragraphs 3.4.2.1. and 3.4.2.2.

3.4.2.1. They shall be submitted to a pulsating test in the configuration of mounting equivalent to the vehicle installation. The test shall be performed by using the Class K coupling. Alternatively the coupling device may be replaced by a jig representing the same environment with the agreement of the Type Approval Authority or Technical Service.

3.4.2.2. They shall be subjected to a dynamic testing as described in paragraph 3.4.1. in respect to the corresponding characteristic values of the coupling device Class K specified by the manufacturer."

Paragraph 3.5.2., amend to read:

"3.5.2. Dynamic test:

- 3.5.2.1. The dynamic test shall be a pulsating test using a Class L toroidal eye and with the coupling mounted as it would be on a vehicle and with all of the necessary parts for vehicle installation. However, any flexible components may be neutralized with the agreement of the type approval authority or technical service;
- 3.5.2.2. ~~For h~~**Hook** type couplings intended for use with hinged drawbar trailers, where the imposed vertical load on the coupling, S , is zero, ~~the test force shall be applied in a horizontal direction simulating a tensile force on the hook and varying between 0.05 D and 1.00 D .~~ **shall be tested in the same manner as described in paragraph 3.3.2.**
- 3.5.2.3. ~~For h~~**Hook** type couplings intended for use with center axle trailers ($S > 0$): ~~the test force shall represent the resultant of the horizontal and vertical forces on the coupling and shall be applied along an angle, α , that is, from top front to bottom rear (see Figure 21), and equivalent to the calculated angle of the resultant between the horizontal and vertical forces on the coupling. The force, $F_{hs\ res}$ shall be calculated as:~~

$$F_{hs\ res} = \sqrt{F_h^2 + F_s^2}, \text{ where } F_h = D_c \text{ and } F_s = \frac{9.81S}{1000} + 0.8V.$$

- 3.5.2.3.1. **Hook type couplings intended for use with centre axle trailers ≤ 3.5 tons shall be tested in the same way as described in 3.1 of this annex.**
- 3.5.2.3.2. **Hook type couplings intended for use with centre axle trailers above 3.5 tons shall be tested in the same way as described in paragraph 3.3.3.2 of this annex."**

Delete paragraph 3.5.2.4.

3.5.2.4. ~~The applied force shall vary between 0.05 F and $hs\ res$ 1.00 $F_{hs\ res}$~~

Annex 7,

Paragraph 1.1., amend to read:

- "1.1. Attachment of coupling balls, **hook couplings** and towing brackets
- 1.1.1. Coupling balls, **hook coupling** and towing brackets shall be attached to vehicles of categories M₁, M₂ (below 3.5t maximum permissible mass) and N1 1/ in a manner which conforms to the clearance and height dimensions given in Figure 25. The height shall be measured at the vehicle loading conditions given in appendix 1 to this annex.
- The height requirement shall not apply in the case of category G off-road vehicles as defined in Annex 7 of the Consolidated Resolution on the Construction of Vehicles (R.E.3) ~~(document TRANS/WP.29/78/Rev.1/Amend.2).~~
- 1.1.1.1. The clearance space shown in Figures 25a and 25b may be occupied by non-demountable equipment, such as a spare wheel, provided that the distance from the **centre** of the ball **or the centre of the hook** on a vertical plane at the extreme rearmost point of the equipment does not exceed ~~300 mm~~/**250 mm** The equipment shall be mounted to allow adequate access for coupling and uncoupling without risk of injury to the user and without affecting articulation of the coupling.
- 1.1.2. For coupling balls **or hook coupling** and towing brackets the vehicle manufacturer shall supply mounting instructions and state whether any reinforcement of the fixing area is necessary.
- 1.1.3. It shall be possible to couple and uncouple ball couplings/**hook coupling** when the longitudinal axis of the ball coupling/**hook coupling** in relation to the center line of the coupling ball/**hook coupling** and mounting:
- is rotated horizontally 60° to right or left, ($\beta = 60^\circ$, see Figure 25);
- is rotated vertically 10° up or down ($\alpha = 10^\circ$, see Figure 25);
- is rotated axially 10° to right or left.
- 1.1.4. When the trailer is not coupled to the towing vehicle, the mounted towing bracket and coupling ball/**hook coupling** shall not obscure the mounting space provided for the rear registration plate or affect the visibility of the rear registration/ license plate of the towing vehicle. If the coupling ball/hook coupling or other items do obscure the rear registration plate they shall be removable or repositionable without the use of tools except, for example, an easily operated (i.e. an effort not exceeding 20 Nm) release key which is carried in the vehicle.

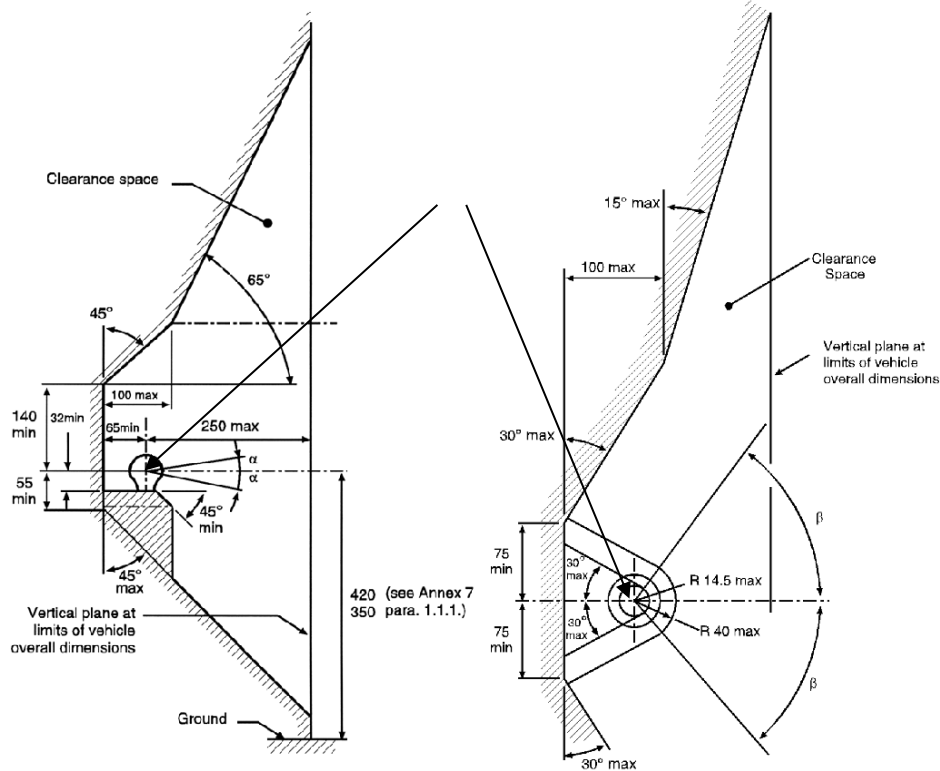

Figure 25 a

Figure 25 b"

Paragraph 1.2., amend to read:

"1.2. Attachment of coupling heads **or toroidal drawbar eyes**.

1.2.1. Class B coupling heads are permitted for trailers of maximum mass up to and including 3.5 tons.

With the trailer horizontal and carrying the maximum permitted axle load, coupling heads or **toroidal drawbar eyes** shall be fitted so that the center line of the spherical area into which the ball fits is 430 ± 35 mm above the horizontal plane on which the wheels of the trailer rest.

In the case of caravans and goods trailers, the horizontal position is regarded as when the floor or loading surface is horizontal. In the case of trailers without such a reference surface (e.g. boat trailers or similar) the trailer manufacturer shall give an appropriate reference line defining the horizontal position. The height requirement shall apply only to trailers intended to be attached to vehicles mentioned in paragraph 1.1.1. of this annex. In all cases the horizontal position shall be determined to within $\pm 1^\circ$.

1.2.2. It shall be possible to operate the coupling heads/ **toroidal drawbar eyes** safely within the free space of the coupling ball/**hook coupling** given in figures 25a and 25b, up to angles of $a = 25^\circ$ and $b = 60^\circ$.

1.2.3. The design of the drawbar including the coupling head/**toroidal drawbar eyes** for use on O1 and O2 center axle trailers shall be such as to prevent the coupling head/**toroidal drawbar eyes** from digging into the ground in the event of separation from the main coupling.

Paragraph 1.3.4., amend to read:

1.3.4. Minimum angle for coupling up and uncoupling

Coupling and uncoupling of the drawbar eye shall be possible when the longitudinal axis of the drawbar eye in relation to the center line of the jaw is simultaneously rotated:

50° horizontally to right or left;

6° vertically up or down;

6° axially to right or left.

This requirement shall also apply to Class K hook type couplings **for vehicles having maximum permissible mass above 3.5t.**"

II. Justification

1. In the market, the existing class K hook type couplings are not completely standard, so we propose to create a new sub class K-X. In the same manner, the existing class L toroidal drawbar eyes are not completely standard, so we propose to create a new sub class L-X (see paras 2.6.10. and 2.6.11.).
2. There are some products belonging to several classes, it is proposed to take into account these multiple applications to inform the final user with the relevant characteristic values of each class (see Table 1 of Annex 4)
3. The current methods of tests for Class K hook type couplings being not representative of the real conditions in service when coupled with toroidal drawbar eyes of class L. The stresses and the damage zone resulting from the only positive test force are different with those of the real conditions in service.
4. In order to take into account this kind of configuration the provisions have been reviewed and adapted by introducing it in test methods (Annex 6, paragraphs 3.4.2. and 3.5.2.)
5. The proposal consists of replacing the only positive test force by an alternating test force as it specified for testing the drawbars eyes.
6. Furthermore, hook couplings being mounted on vehicles of categories M_1 , M_2 (≤ 3.5 t) and N_1 , are subject to the provisions in the Annex 7 (on to the installation) in order to apply the same requirements as the coupling balls (see paras 1.1.1. to 1.1.4.).
7. Likewise, toroidal drawbar eyes can be mounted on some kind of trailers, then they have been introduced in the annex 7 relative to the installation in order to apply the same requirements as the coupling heads(see paras 1.2.1. to 1.2.3.).
8. Finally hook couplings mounted on vehicles of categories M_1/M_2 (≤ 3.5 t) and $N1$ shall also fulfill paragraph 1.1.3. In order to be consistent between the different specifications for each Class of couplings, Classes A/B/K ≤ 3.5 t, and Classes of attachment for vehicles > 3.5 t, the scope of the paragraph 1.3.4. shall be limited to the vehicle of permissible mass above 3.5t.