



Economic and Social Council

Distr.: General
24 August 2015

Original: English

Economic Commission for Europe

Inland Transport Committee

World Forum for Harmonization of Vehicle Regulations

167th session

Geneva, 10-13 November 2015

Item 4.8.3 of the provisional agenda

**1958 Agreement – Consideration of draft amendments
to existing Regulations submitted by GRSP**

Proposal for Supplement 10 to the 04 series of amendments to Regulation No. 44 (Child restraint systems)

Submitted by the Working Party on Passive Safety *

The text reproduced below was adopted by the Working Party on Passive Safety (GRSP) at its fifty-seventh session (ECE/TRANS/WP.29/GRSP/57, para. 23). It is based on ECE/TRANS/WP.29/GRSP/2015/5 not amended. It is submitted to the World Forum for Harmonization of Vehicle Regulations (WP.29) and to the Administrative Committee AC.1 for consideration.

* In accordance with the programme of work of the Inland Transport Committee for 2012–2016 (ECE/TRANS/224, para. 94 and ECE/TRANS/2012/12, programme activity 02.4), the World Forum will develop, harmonize and update Regulations in order to enhance the performance of vehicles. The present document is submitted in conformity with that mandate.

Insert new paragraphs 2.41. to 2.43., to read:

- "2.41. *"Child Restraint System Displacement system"* means a device enabling the CRS or one of its parts to be displaced angularly or longitudinally.
- 2.42. *"Child Restraint System Locking system"* means a device ensuring that the CRS and its parts are maintained in the position of use.
- 2.43. *"Load limiting device"* means a device that can break or jam under specified loading conditions. The device shall be explicitly designed for these conditions and its behaviour shall be reproducible and objectively documented in the technical documentation."

Paragraph 3.2.1., amend to read

- "3.2.1. A technical description of the child restraint, specifying the straps and other materials used together with the predicted and reproducible behaviour of load limiting devices. It shall be accompanied by drawings of the parts making up the child restraint and in the case of retractors, installation instructions for these retractors and their sensing devices, declaration on toxicity (paragraph 6.1.5.) and flammability (paragraph 6.1.6.), the drawings shall show the position intended for the approval number and additional symbol(s) in relation to the circle of the approval mark. The description shall mention the colour of the model submitted for approval;"

Paragraph 4.3., amend to read:

- "4.3. If the restraint is to be used in combination with an adult safety belt the correct routing of the webbing shall be clearly indicated by means of a drawing permanently attached to the restraint. If the restraint is held in place by the adult safety-belt, the routes of the webbing shall be clearly marked on the product by colour coding. The colours for the safety-belt route to be used when the device is installed forward facing shall be red and when installed rear-facing shall be blue. Devices that can be installed rearward and forward facing without changing the belt routing (e.g. turnable system) shall use both colours. The same colours shall also be used on the labels on the device that illustrate the methods of use.

There shall be a clear differentiation ..."

"Paragraph 7.1.4.1.4., amend to read

- 7.1.4.1.4. During the dynamic tests, no part of the child restraint actually helping to keep the child in position shall break, and no buckles or locking system or displacement system or support leg shall break or release or collapse, except where identified as a load limiting device. Any load limiting device shall be clearly identified in the manufacturer's technical descriptions as defined in paragraph 3.2.1. of this Regulation."

Paragraph 7.1.4.1.10.1.2., amend to read:

- "7.1.4.1.10.1.2. Without the anti-rotation device in use. If the anti-rotation device is a support leg and it can be completely recessed within the base or the shell of the CRS, the test is conducted with the device in its stowed position or with the leg removed respectively. If it cannot be completely recessed within the base, the test is performed with the device deployed in its shortest length with the trolley floor pan in its lowest position.

This requirement does not apply when a permanent and non-adjustable support leg is used as an anti-rotation device."

Paragraph 8.1.3.6.3.2., amend to read

"8.1.3.6.3.2. Place the child chair on the test seat.

Place the manikin in the child chair.

For restraints or straps acting directly on a retractor or adult three point safety belt, where no lock off device or any system able to inhibit the action of the retractor is used:

- (a) Fit the belt in accordance with the manufacturer's instructions.
- (b) Complete the installation of the child chair to the test seat in accordance with Annex 21 to this Regulation.

For all other restraints:

- (a) Place a hinged board or a similar flexible device 2.5 cm thick and 6 cm wide and of length equal to the shoulder height (sitting, Annex 8) less the hip centre height (sitting, in Annex 8 popliteus height plus half of thigh height, sitting) relevant to the manikin size being tested between the manikin and the seat back of the chair. The board should follow as closely as possible the curvature of the chair and its lower end should be at the height of the manikin's hip joint.
- (b) Adjust the belt in accordance with the manufacturer's instructions, but to a tension of 250 ± 25 N above the adjuster force, with a deflection angle of the strap at the adjuster of $45 \pm 5^\circ$, or alternatively, the angle prescribed by the manufacturer.
- (c) Complete the installation of the child chair to the test seat in accordance with Annex 21 to this Regulation.
- (d) Remove the flexible device."

Paragraphs 8.2.5.2.6.2. to 8.2.5.2.6.3.2., amend to read:

"8.2.5.2.6.2. The table below sets out the general conditions for each test:

	<i>Load [N]</i>	<i>Cycles per minute</i>	<i>Cycles (No.)</i>
Type 1 procedure	60 ± 0.5	30 ± 10	$1,000 \pm 5$
Type 2 procedure	10 ± 0.1	30 ± 10	$5,000 \pm 5$

8.2.5.2.6.3. Particular test conditions

8.2.5.2.6.3.1. Type 1 procedure: for cases where the strap slides through the quick adjusting device. Apply a load of 10 N, if necessary the load may be increased by 10 N steps so as to permit correct sliding, but limited to a maximum of 60 N. This load shall be vertically and permanently applied on the straps. The part of the strap set horizontally shall pass through the quick adjuster it is fitted to and shall be attached to a device, giving the webbing a back and forth motion. The quick adjusting device shall be so placed that the horizontal strap of the webbing remains under tension (see Annex 5, Figure 1). Activate the quick adjuster while pulling the straps in the direction to slacken the harness and deactivate it while pulling the straps in the direction to tighten the harness.

8.2.5.2.6.3.2. Type 2 procedure: for cases where the strap changes direction in passing through a rigid part. During this test, the webbing shall pass through the rigid

part it is intended for and the test set up shall reproduce the angles as in the real installation (in three dimensions), see Annex 5, Figure 2 for examples. The 10 N load shall be permanently applied. For cases where the strap changes direction more than once in passing through a rigid part, the load of 10 N may be increased by 10 N steps so as to permit correct sliding and achieve the prescribed 300 mm of strap movement through that rigid part."

Annex 5, amend to read:

"Annex 5

Abrasion and microslip test

Figure 1
Procedure type 1

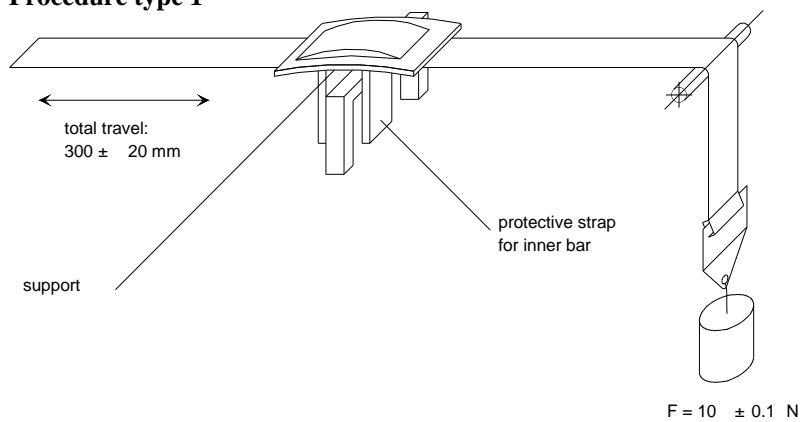

Example a

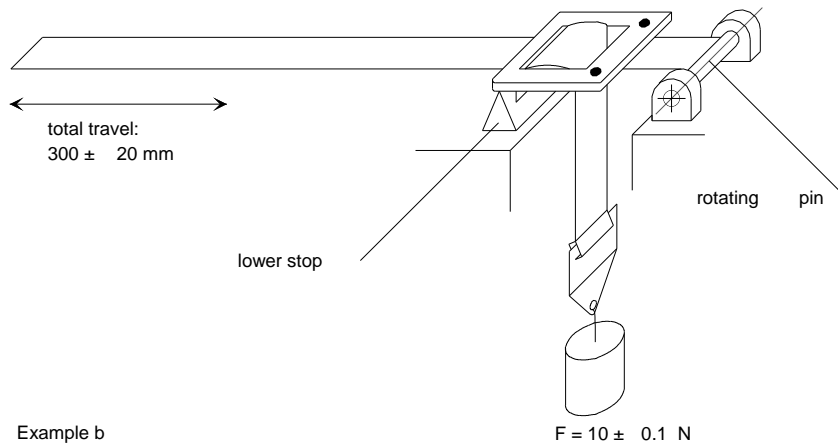

Example b
Examples of test arrangements corresponding to the type of adjusting device

Remark. $F = 10 \pm 0.1 \text{ N}$, can be increased up to $F = 60 \pm 0.5 \text{ N}$

Figure 2
Procedure type 2
Following two examples of test set up;
Example 1

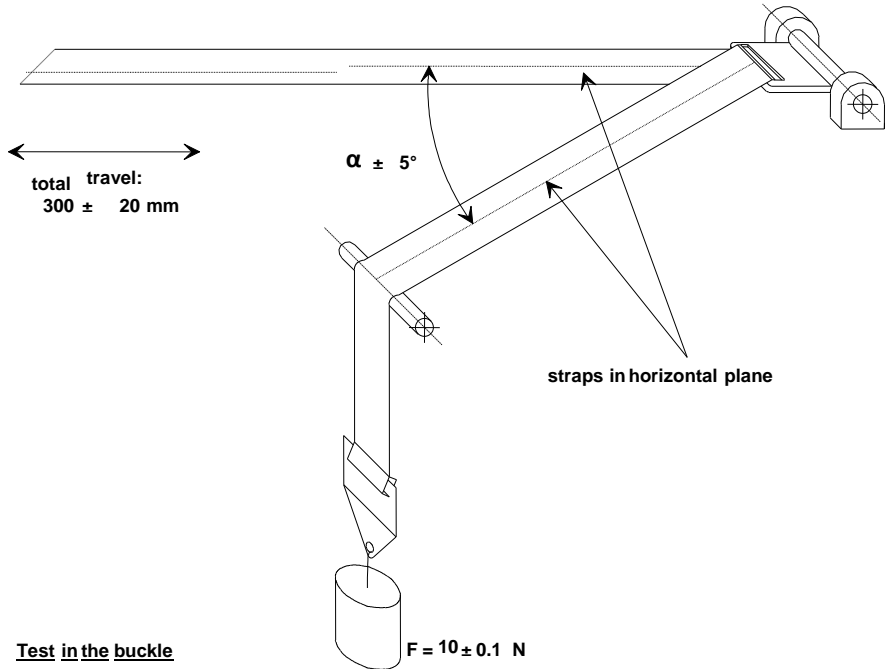

Example 2

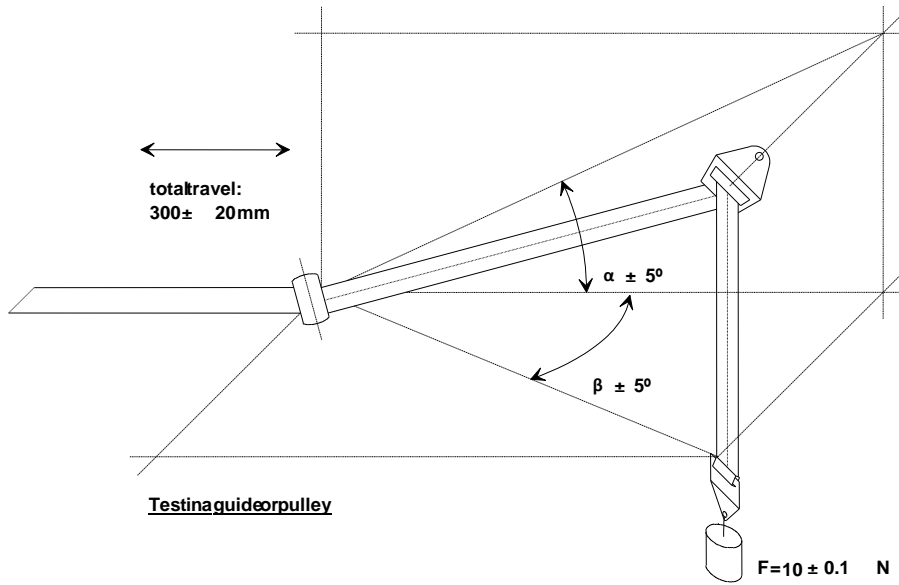

Where α and β reproduce the angles as in the real installation (in three dimensions).

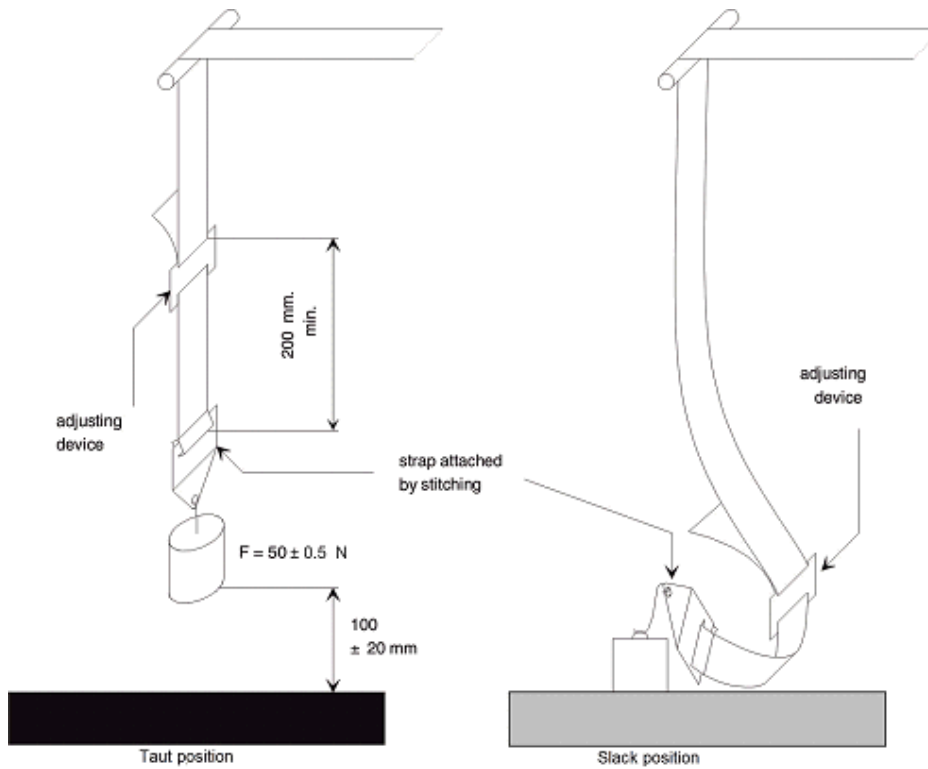

The load of 50 N on the testing device shall be vertically guided in such a way as to prevent load-swing and twisting of the strap. The attaching device shall be fixed to the load of 50 N in the same manner as in the vehicle."

Annex 15

Insert new explanatory notes on paragraphs 7.1.4.1.4., 7.1.4.1.10.1.2., 8.1.3.6.3.2. and 10.1.3., to read:

"Paragraph 7.1.4.1.4.

The paragraph aims to ensure that the CRS will sustain all imposed loads during the dynamic test, keeping the child in position, by maintaining the original position and configuration. Any change in the original configuration, including change in the reclining position or in the support leg length shall be considered a failure. Any load bearing part or component failure, like adult safety belt contact points (identified as a belt route), anti-rotation device or CRS chair shell shall be considered a failure, except where such behaviour is clearly identified as load limiting device function.

Paragraph 7.1.4.1.10.1.2.

Completely recessed means that with the leg in the stowed position, no part of the leg protrudes beyond the surface of the base or shell, such that it has no effect on the position of the CRS on the test bench. See the following figures for clarification examples.

Figure 1
Examples of completely recessed support leg

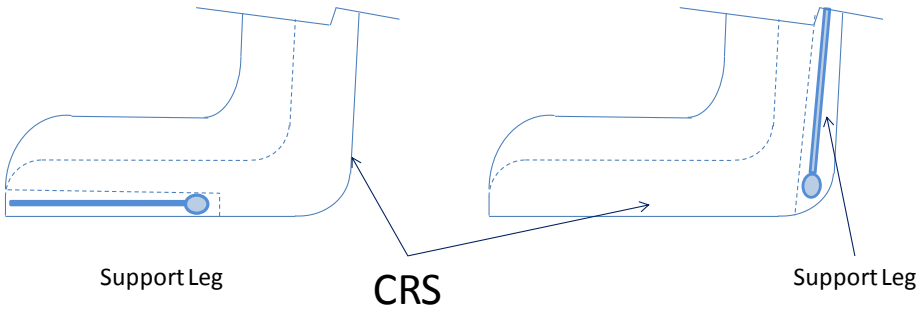
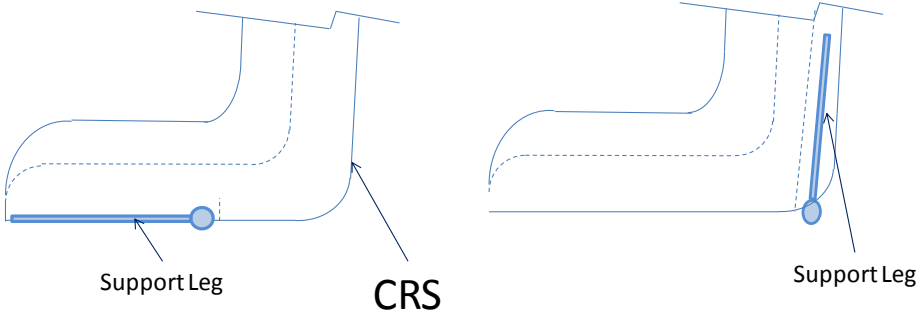

Figure 2
Examples of not completely recessed support leg



Paragraph 8.1.3.6.3.2.

The hinged board or similar flexible device is intended to simulate the removal of clothing from the child and a failure to re-adjust the harness system. Where the child is restrained by a system that adjusts to fit the child's physique without external intervention (where the adult belt is used or the harness contains automatic or emergency locking retractors), it shall not be necessary to use the hinged board. For child restraint systems where the length of the straps can be fixed (for example a harness without retractors or the adult belt is used with a lock-off), the use of the hinged board is required. The hinged board must be used for the setup of CRS using belted impact shields.

Paragraph 10.1.3.

10.1.3. In the case of extensions where the modifications affect only one CRS group, perform extension test only for that group, and if the excursion result is worse than for the previous worst case for the CRS (from any group from the original approval or previous extensions) then conduct new production qualification tests. If the head excursion is no worse than any other previous approval or extension testing (excluding PQ tests) further production qualification testing is not required.

In cases where the extension modifications affect more than one group, for example if extending a group 2/3 CRS to add group 1, but the modification can affect group 2/3 (e.g.: strengthening), then perform group 1 tests and the worst case group 2/3 (original approval). If any result is worse than the original approval or previous extension (excluding PQ tests) then perform production qualification tests on the new worst case.

Always compare to the worst case from all approval and extension testing (excluding any PQ tests)."
