

**Proposal for Amendment [x] to global technical regulation
No. 9 (Pedestrian safety)**

**Proposal for further amendments to document
GRSP-54-33, submitted by the informal working group on global
technical regulation No. 9**

The text reproduced below was prepared by the Task Force Bumper Test Area (TF-BTA), a subgroup of the Informal Working Group on gtr No. 9 – Phase 2. The modifications to the current text of UN gtr No. 9 are marked in bold for new or strikethrough for deleted characters. The modifications are related to Phase 2 of the global technical regulation No. 9 only.

I. Proposal

In the text of the regulation (part B),

[Insert new Paragraph 3.9., to read:

- 3.9. Bumper beam means the structural cross member under the bumper fascia protecting the front of the vehicle. The beam does not include foam, cover support or any pedestrian protection devices.**

Paragraphs 3.9 to 3.31., renumber as paragraphs 3.10. to 3.32.]

Paragraph 3.101. amend to read:

- 3.101. "Bumper test area" means ~~the frontal surface of the bumper limited by two longitudinal vertical planes intersecting the corners of the bumper and moved 66 mm parallel and inboard of the corners of the bumpers. [either] the area limited by the bumper corners as defined in paragraph 3.14. and moving on either side 42 mm inboard parallel to a lateral vertical vehicle plane [or the outermost ends of the bumper beam/lower rails/cross beam structures as defined in paragraph 3.9. (see Figure 5D), or between a bumper corner and outermost end of the bumper beam, whichever area is larger].~~

Paragraph 3.134. amend to read:

- 3.134. "Corner of bumper" means the vehicle's point of contact with a vertical plane which makes an angle of 60° with the vertical longitudinal plane of the car and is tangential to the outer surface of the bumper (see Figure 5). ~~corner gauge as defined in Figure 5B.~~

The transversal position of the corner of bumper is determined with a corner gauge as defined in Figure 5B.

For determination of the corner of bumper the front surface of the corner gauge is moved parallel to a vertical plane with an angle of 60° to the vertical longitudinal centre plane of the vehicle (see Figures 5A and 5C) at all heights of the horizontal centre line of the corner gauge in the following area:

- a. Equal or above a point found in vertical direction on the Lower Bumper Reference Line at the assessment position in transversal direction or at 75 mm above the ground reference plane, whichever is higher.**
- b. Equal or below to a point found in vertical direction on the Upper Bumper Reference Line at the assessment position in transversal direction or at 1003 mm above the ground reference plane, whichever is lower.**

For determination of the corner of bumper the gauge is moved to contact the outer contour of the vehicle touching at the vertical centreline of the gauge.

The corner of bumper is then defined as the outermost point of contact of the gauge with the outer contour of the vehicle according to this procedure.

Figure 5, amend to read:

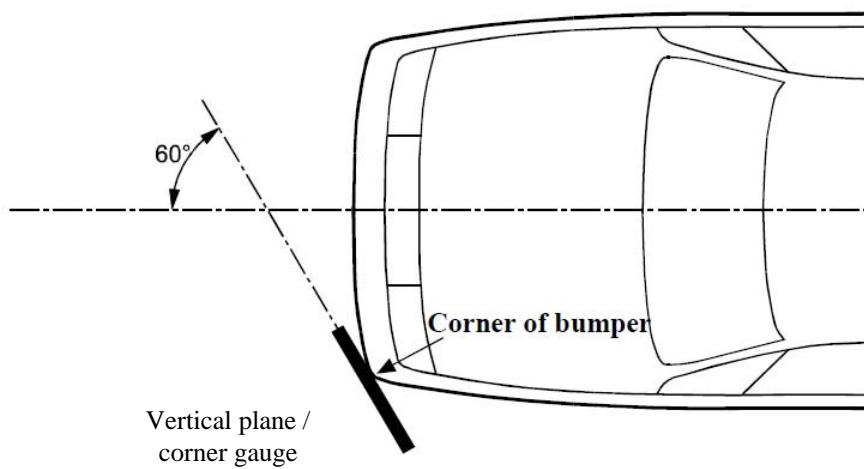
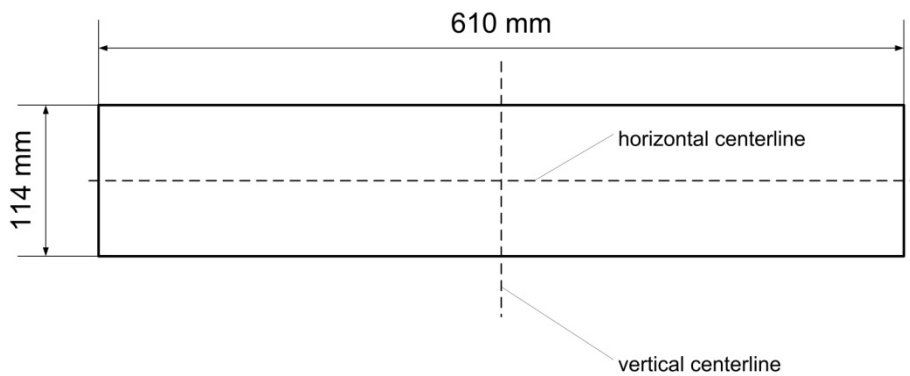

Figure 5A: Corner of bumper (see paragraph 3.13.)



The front surface of the corner gauge is flat

Figure 5B: Corner Gauge

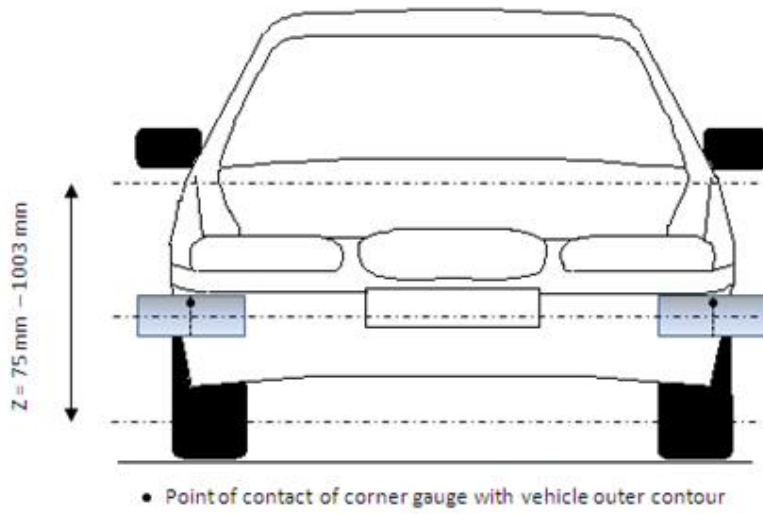

Figure 5C: Determination of Corner of Bumper with corner gauge

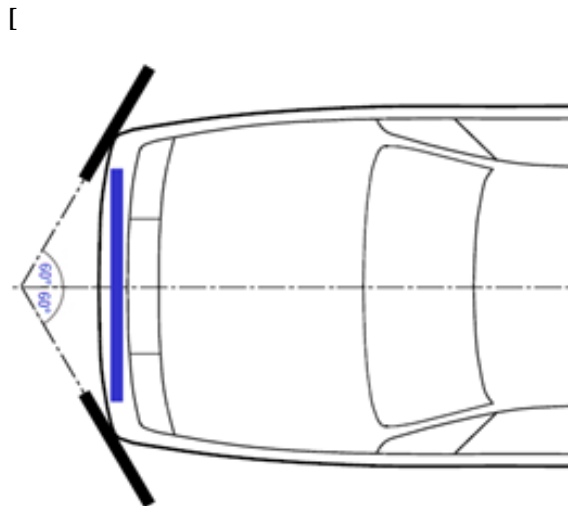

Figure 5D: Determination of bumper test area]