Proposal for an amendment to UN Regulation No. 43 to define a *reduced vision zone I* for vehicles of categories M and N other than M₁

I. Proposal

Proposed changes respectively extensions are highlighted in red colour

Annex 3

General test conditions

1. Fragmentation Test thru 9.2.4. Number of windscreens **are kept unchanged**
 - 9.2.5. Definitions of zones
 - 9.2.5.1. Zones A and B of windscreens for vehicle category M₁ and N₁ are defined in Annex 18 to this Regulation.
 - 9.2.5.2. Zones of windscreens for vehicles of categories M and N other than M₁ are defined on the basis of:
 - 9.2.5.2.1. The "eye-point" or the "O" point" means the point located 625 mm above the R point of the driver's seat in the vertical plane parallel to the longitudinal median plane of the vehicle for which the windscreen is intended, passing through the axis of the steering wheel.
 - 9.2.5.2.2. The straight line OQ which is the horizontal straight line passing through the eye point O and perpendicular to the median longitudinal plane of the vehicle.
 - 9.2.5.2.3. Zone I is the windscreen zone determined by the intersection of the windscreen with the four planes defined below:
 - P1 - A vertical plane passing through O and forming an angle of 15° to the left of the median longitudinal plane of the vehicle;
 - P2 - A vertical plane symmetrical to P1 about the median longitudinal plane of the vehicle.

If this is not possible (in the absence of a symmetrical median longitudinal plane, for instance) P2 shall be the plane symmetrical to P1 about the longitudinal plane of the vehicle passing through point O.
 - P3 - A plane passing through the straight line OQ and forming an angle of 10° above the horizontal plane;
 - P4 - A plane passing through the straight line OQ and forming an angle of 8° below the horizontal plane.
 - 9.2.5.3. The reduced test area I is the test area I as defined in 9.2.5.2.3 with the exclusion of the following area (see figure 11).
 - 9.2.5.3.1. Any opaque obscuration bounded downwards by plane 5, a plane passing through the straight line OQ and forming an angle of 5° above the horizontal plane and laterally by planes 6 and 6', vertical planes parallel to the longitudinal median plane of the vehicle in a distance of 150 mm to the trace of the longitudinal median plane of the vehicle (CL)⁹.

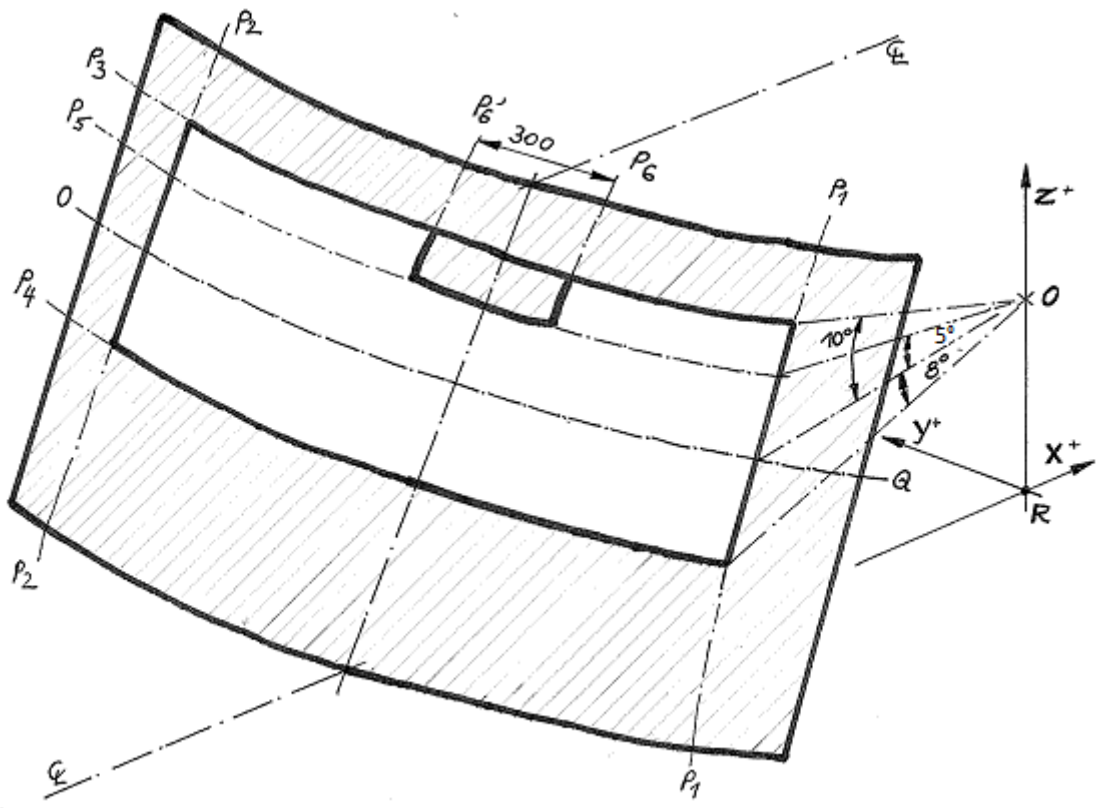

⁹ Measured on the outer surface of the windscreen and on the trace of plane 5.

If this is not possible (in the absence of a symmetrical median longitudinal plane, for instance) P6 and P6' shall be the planes parallel to the longitudinal plane of the vehicle passing through point 0.

Figure 11

CL : trace of the longitudinal median plane of the vehicle

P_i : trace of the relevant plane (see text)

9.2.5.4. For agricultural and forestry tractors and for construction-site vehicles for which it is not possible to determine zone I, zone I' consists in the whole transparent surface of the windscreen.

9.2.6. Interpretation of results

A windscreen type shall be considered satisfactory with respect to optical distortion if, in the four windscreens submitted for testing, optical distortion does not exceed the values given below for each zone or test area.

<i>Vehicle category</i>	<i>Zone</i>	<i>Maximum values of optical distortion</i>
M ₁ and N ₁	A - extended according to para. 9.2.2.1.	2' of arc
	B - reduced according to para. 2.4. of Annex 18	6' of arc
M and N categories other than M ₁	I – reduced according to para.9.2.5.3.	2' of arc
Agricultural vehicles etc. for which it is not possible to determine zone I	I'	2' of arc

9.2.6.1. No measurements shall be made in a peripheral area 25 mm inboard of the design glass outline and of any opaque obscuration, provided that it does not impinge into the extended zone A or zone I.

9.2.6.2. For agricultural and forestry tractors and for construction-site vehicles, no measurements shall be made in a peripheral area 100 mm wide.

9.2.6.3. In the case of split windscreens, no measurements shall be made in a strip 35 mm from the edge of the windscreen, which is adjacent to the dividing, pillar.

9.2.6.4. A maximum value of 6' of arc is permitted for all portions of zone I or zone A in a peripheral area 100 mm inboard of the design glass outline.

9.2.6.5. Slight deviations from the requirements may be allowed in the reduced test area B according to paragraph 2.4. of Annex 18 provided they are localized and recorded in the report.

9.3. Secondary-image-separation test

9.3.1. Scope

Two test methods are recognized:

Target test, and

Collimation-telescope test.

These test methods may be used for approval, quality-control or product-evaluation purposes, as appropriate.

9.3.1.1. Target test

9.3.1.1.1. Apparatus

This method involves viewing an illuminated target through the safety glazing. The target may be designed in such a way that the test can be carried out on a simple 'go-no go' basis.

The target shall preferably be of one of the following types; that is to say, either

- (a) An illuminated 'ring' target whose outer diameter, D , subtends an angle of n minutes of arc at a point situated at x metres (Figure 12 (a)),
or
- (b) An illuminated 'ring and spot' target whose dimensions are such that the distance D from a point on the edge of the spot to the nearest point on the inside of the circle subtends an angle of n minutes of arc at a point situated at x metres (Figure 12 (b)), where
 - n is the limit value of secondary-image separation,
 - x is the distance from the safety glazing to the target (not less than 7 m),
 - D is given by the formula: $D = x \cdot \text{tg } n$

The illuminated target consists of a light box, approximately 300 mm x 300 mm x 150 mm, whose front is most conveniently constructed of glass masked with opaque black paper or coated with matt black paint.

The box shall be illuminated by a suitable light source. It may be convenient to use other forms of target, such as that shown in Figure 15. It is also acceptable to replace the target system by a projection system and to view the resulting images on a screen.

9.3.1.1.2. Procedure

Mount the windscreen at the specified rake angle on a suitable stand in such a way that the observation is carried out in the horizontal plane passing through the centre of the target. The light box shall be viewed in a dark or semi-dark room, through each part of the area being examined, in order to detect the presence of any secondary image associated with the illuminated target. Rotate the windscreen as necessary to ensure that the correct direction of view is maintained. A monocular may be used for viewing.

9.3.1.1.3. Expression of results

Determine whether,

When target (a) (see Figure 12 (a)) is used, the primary and secondary images of the circle separate, i.e. whether the limit value of n is exceeded, or

When target (b) (see Figure 12 (b)) is used, the secondary image of the spot shifts beyond the point of tangency with the inside edge of the circle, i.e. whether the limit value of n is exceeded.

Figure 12
Dimensions of targets

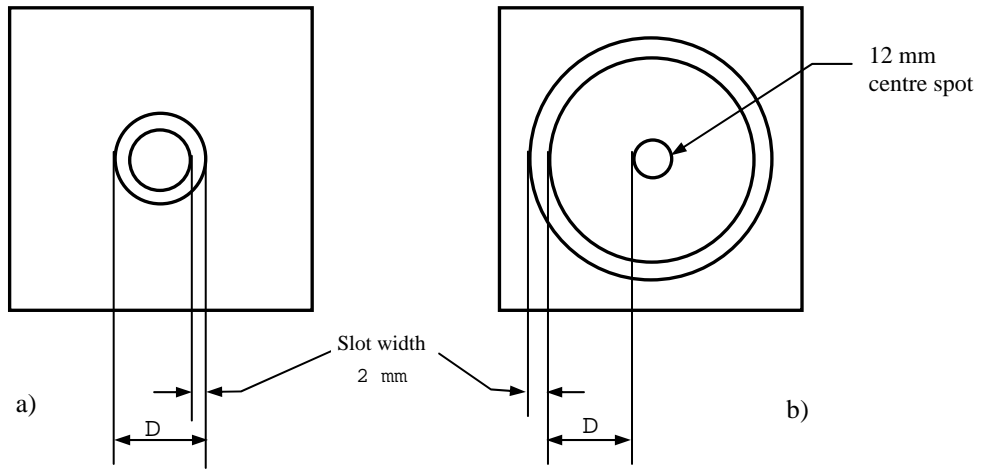

Figure 13 Arrangement of apparatus

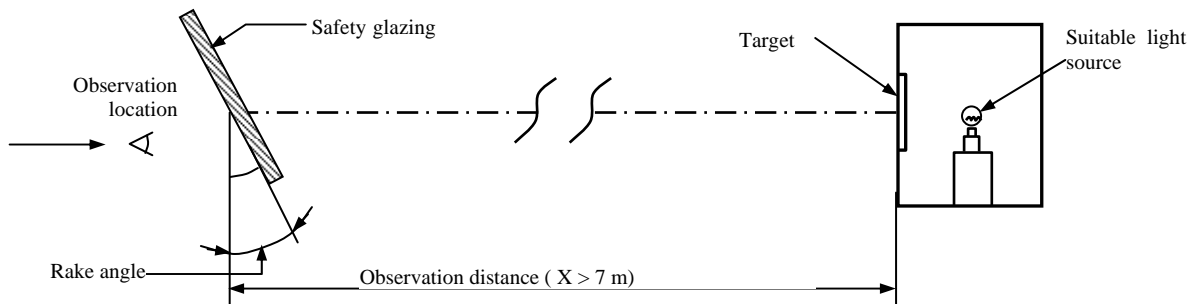
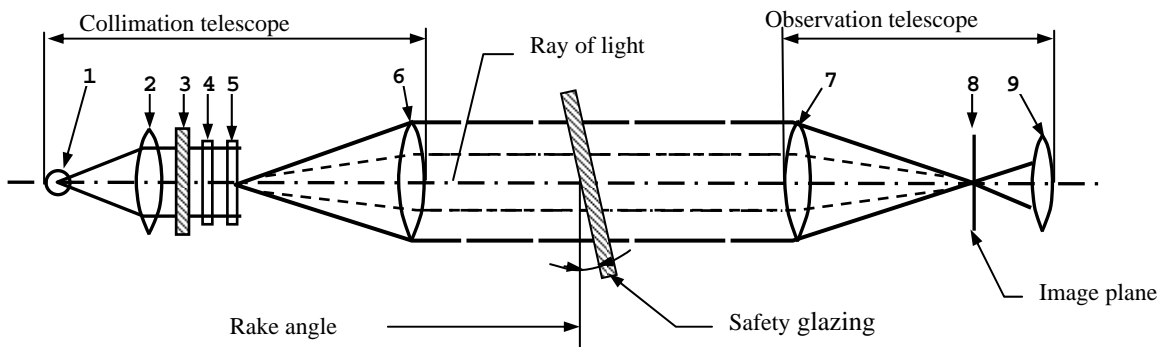

Figure 14
Apparatus for collimation-telescope test



- (1) Lamp bulb
- (2) Condenser aperture > 8.6 mm
- (3) Ground-glass screen aperture > condenser aperture
- (4) Colour filter with central hole approximately 0.3 mm in diameter, diameter > 8.6 mm
- (5) Polar co-ordinate plate, diameter > 8.6 mm
- (6) Achromatic lens, $f \geq 86$ mm, aperture 10 mm
- (7) Achromatic lens, $f \geq 86$ mm, aperture 10 mm
- (8) Black spot, diameter approximately 0.3 mm
- (9) Achromatic lens, $f = 20$ mm, aperture < 10 mm.

9.3.1.2. Collimation-telescope test

If necessary, the procedure described in this paragraph shall be applied.

9.3.1.2.1. Apparatus

The apparatus comprises a collimator and a telescope and may be set up in accordance with [Figure 14](#). However, any equivalent optical system may be used.

9.3.1.2.2. Procedure

The collimation telescope forms at infinity the image of a polar co-ordinate system with a bright point at its centre (see [Figure 15](#)).

In the focal plane of the observation telescope, a small opaque spot with a diameter slightly larger than of the projected bright point is placed on the optical axis, thus obscuring the bright point.

When a windscreen which exhibits a secondary image is placed between the telescope and the collimator, a second, less bright point appears at a certain distance from the centre of the polar co-ordinate system. The secondary-image separation can be read out as the distance between the points seen through the observation telescope (see [Figure 15](#)). (The distance between the dark spot and the bright point at the centre of the polar coordinate system-represents the optical deviation).

9.3.1.2.3. Expression of results

The windscreen shall first be examined by a simple scanning technique to establish the area giving the strongest secondary image. That area shall then be examined by the collimation-telescope system at the appropriate angle of incidence. The maximum secondary-image separation shall be measured.

9.3.1.3. The direction of observation in the horizontal plane shall be maintained approximately normal to the trace of the windscreen in that plane.

9.3.2. The measurements shall be performed in the zones as defined in paragraph 9.2.2. above according to the vehicle categories.

9.3.2.1. Vehicle type

The test shall be repeated if the windscreen is to be fitted to a vehicle of a type in which the forward field of vision differs from that of the vehicle type for which the windscreen has already been approved.

9.3.3. Indices of difficulty of the secondary characteristics

9.3.3.1. Nature of the material

<i>Polished (plate) glass</i>	<i>Float glass</i>	<i>Sheet glass</i>
1	1	2

9.3.3.2. Other secondary characteristics

No other secondary characteristics are involved.

9.3.4. Number of windscreens

Four windscreens shall be submitted for testing.

Figure 15
Example of observation by the collimation-telescope test method

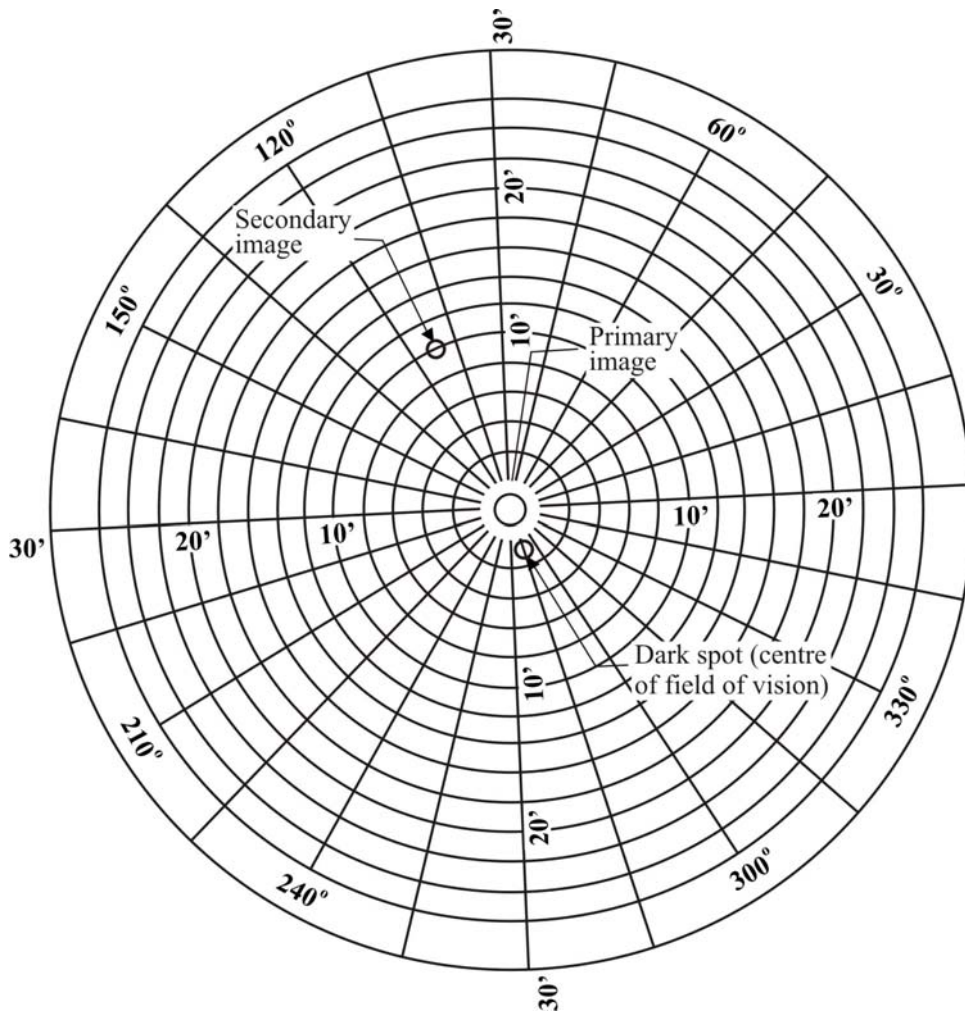

9.3.5. Interpretation of Results

A windscreen type shall be considered satisfactory with respect to secondary image separation if, in the four windscreens submitted for testing, separation of the primary and secondary – images does not exceed the values given below for each zone or test area.

Vehicle category	Zone	Maximum values of optical distortion
M ₁ and N ₁	A - extended according to para. 9.2.2.1.	15' of arc
	B - reduced according to para. 2.4. of Annex 18	25' of arc
M and N categories other than M ₁	I – reduced according to para.9.2.5.3.	15' of arc
Agricultural vehicles etc. for which it is not possible to determine zone I	I'	15' of arc

- 9.3.5.1. No measurements shall be made in a peripheral area 25 mm inboard of the design glass outline and of any opaque obscuration, provided that it does not impinge into the extended zone A or zone I.
 - 9.3.5.2. For agricultural and forestry tractors and for construction-site vehicles, no measurements shall be made in a peripheral area 100 mm wide.
 - 9.3.5.3. In the case of split windscreens, no measurements shall be made in a strip 35 mm from the edge of the windscreen, which is adjacent to the dividing pillar.
 - 9.3.5.4. A maximum value of 25' of arc is permitted for all portions of zone I or zone A in a peripheral area 100 mm inboard of the design glass outline.
 - 9.3.5.5. Slight deviations from the requirements may be allowed in the reduced test area B according to paragraph 2.4. of Annex 18 provided they are localized and recorded in the report.
10. Burning behaviour (fire-resistance) test
- 10.1. Purpose and scope of application
- This method enables the horizontal burning rate of materials used in the passenger compartment of motor vehicles (for example, private passenger cars, lorries (trucks), estate cars, motor coaches) after exposure to a small flame to be determined.
- This method permits testing of materials and components of a vehicle's interior equipment individually or in combination up to a thickness of 13 mm. It is used to judge the uniformity of production lots of such materials with respect to their burning behaviour.
- Because of the many differences between the real-world situation (application and orientation within a vehicle, conditions of use, ignition source, etc.) and the precise test conditions prescribed herein, this method cannot be considered as suitable for evaluation of all true in-vehicle burning characteristics.
- 10.2. Definitions
- 10.2.1. Burning rate: The quotient of the burnt distance measured according to this method and the time taken to burn that distance. It is expressed in millimetres per minute.
- 10.2.2. Composite material: A material composed of several layers of similar or different materials intimately held together at their surfaces by cementing, bonding, cladding, welding, etc.
- When different materials are connected together intermittently (for example, by sewing, high-frequency-welding, riveting), then in order to permit the preparation of individual samples in accordance with paragraph 10.5. below such materials shall not be considered as composite materials.
- 10.2.3. Exposed side: The side which is facing towards the passenger compartment when the material is mounted in the vehicle.
- 10.3. Principle
- A sample is held horizontally in a U-shaped holder and is exposed to the action of a defined low-energy flame for 15 seconds in a combustion chamber, the flame acting on the free end of the sample. The test determines whether and when the flame is extinguished or the time which the flame requires to proceed over a measured distance.

10.4. Apparatus

- 10.4.1. Combustion chamber (Figure 16), preferably of stainless steel, having the dimensions given in Figure 17.

The front of the chamber contains a flame-resistant observation window, which may cover the entire front and which can be constructed as an access panel.

The bottom of the chamber has vent holes, and the top has a vent slot all around. The combustion chamber is placed on four feet, 10 mm high. The chamber may have a hole at one end for the introduction of the sample holder containing the sample; in the opposite end, a hole is provided for the gas-supply line. Melted material is caught in a pan (see Figure 18) which is placed on the bottom of the chamber between vent holes without covering any vent hole area.

Figure 16
Example of combustion chamber with sample holder and drip pan

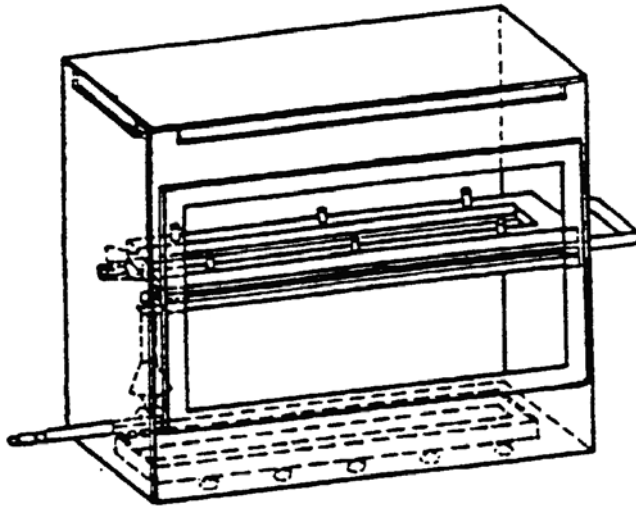

- 10.4.2. Sample holder, consisting of two U-shaped metal plates or frames of corrosion-proof material. Dimensions are given in Figure 19.

The lower plate is equipped with pins and the upper one with corresponding holes, in order to ensure a consistent holding of the sample. The pins also serve as measuring points at the beginning and end of the burning distance.

A support shall be provided in the form of heat-resistant wires 0.25 mm in diameter spanning the frame at 25-mm intervals over the bottom U-shaped frame (see Figure 20).

The plane of the lower side of samples shall be 178 mm above the floor plate. The distance of the front edge of the sample holder from the end of the chamber shall be 22 mm; the distance of the longitudinal sides of the sample holder from the sides of the chamber shall be 50 mm (all inside dimensions). (See Figures 16 and 17).

10.4.3. Gas burner

The small ignition source is provided by a Bunsen burner having an inside diameter of 9.5 mm. It is so located in the test cabinet that the centre of its nozzle is 19 mm below the centre of the bottom edge of the open end of the sample (see Figure 17).

10.4.4. Test gas

The gas supplied to the burner shall have a calorific value of about 38 MJ/m³ (for example natural gas).

10.4.5. Metal comb, at least 110 mm in length, with seven or eight smooth rounded teeth per 25 mm.

Figure 17
Example of combustion chamber

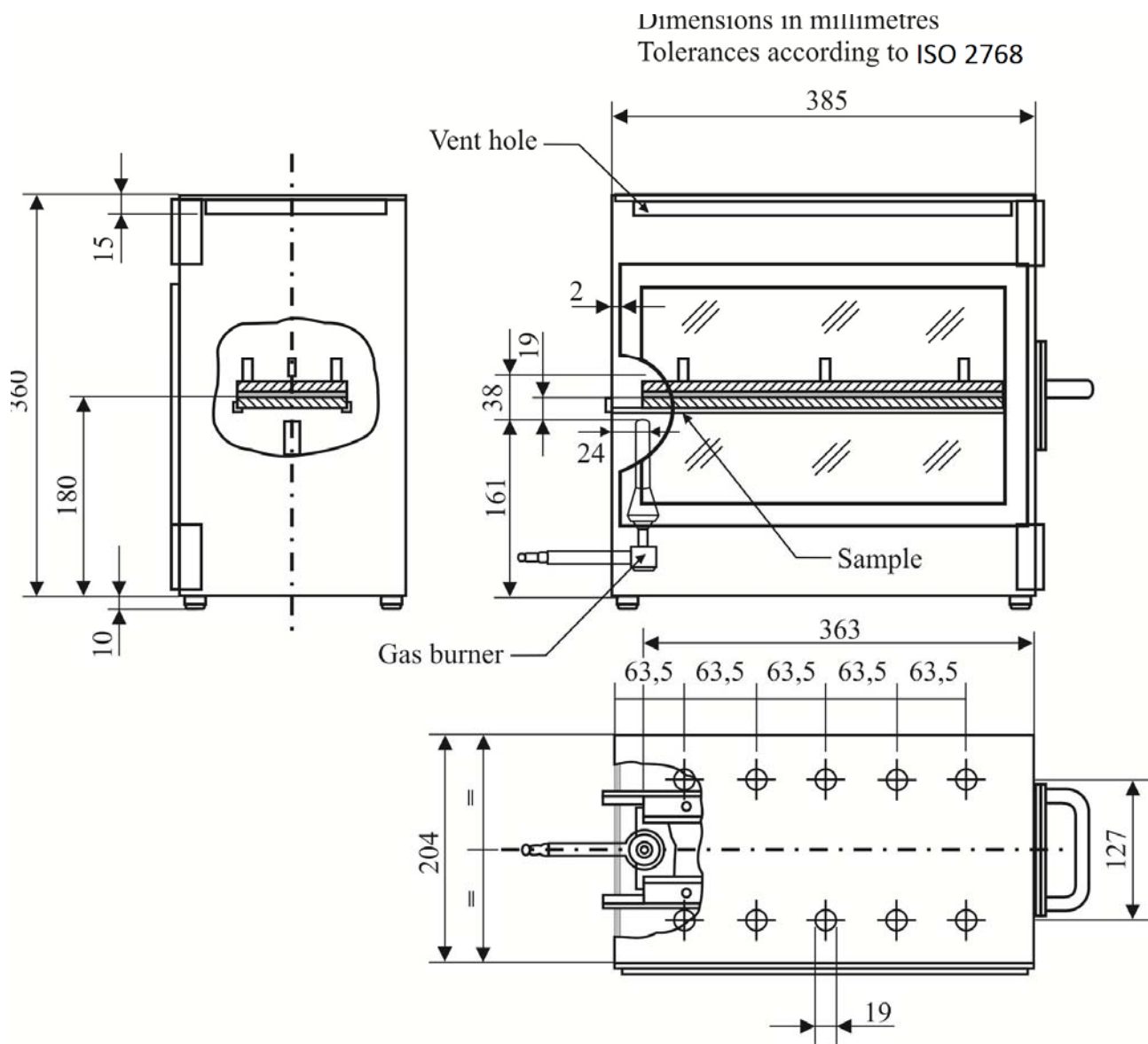

Figure 18
Typical drip pan

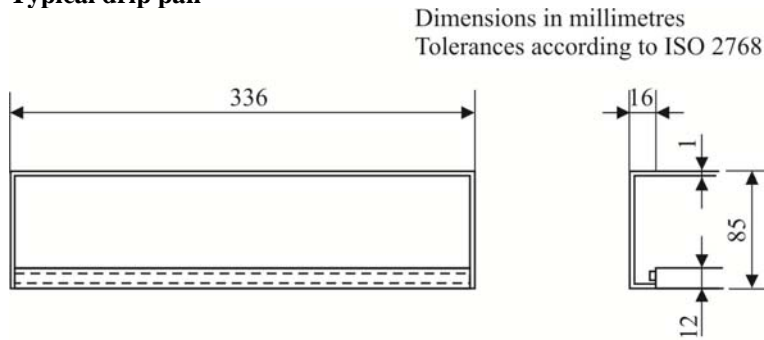

Figure 19
Example of sample holder

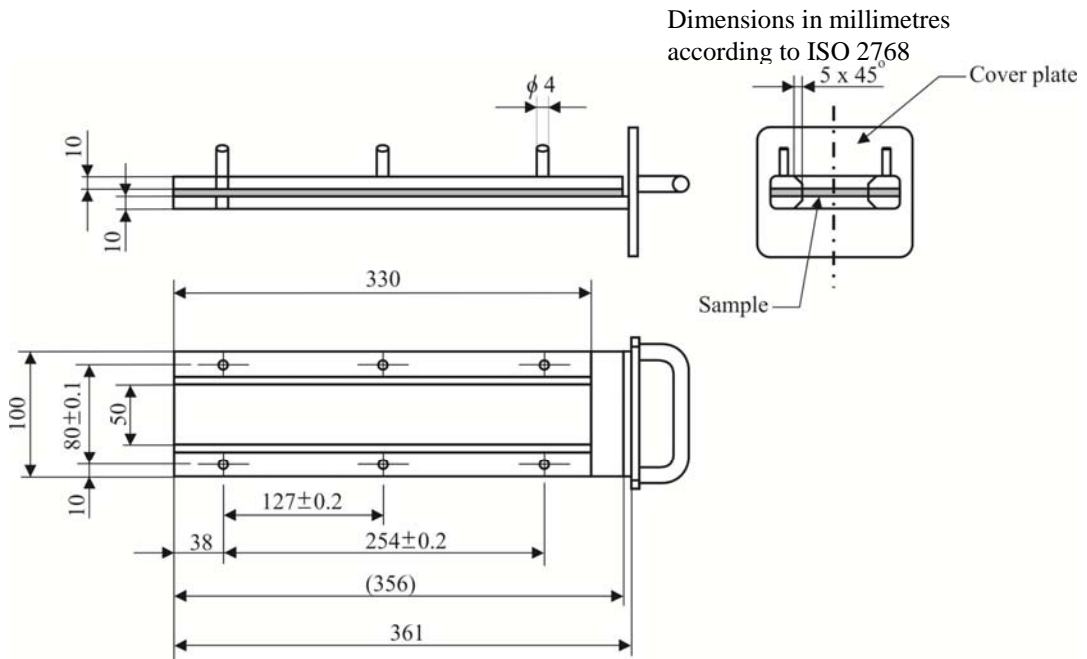
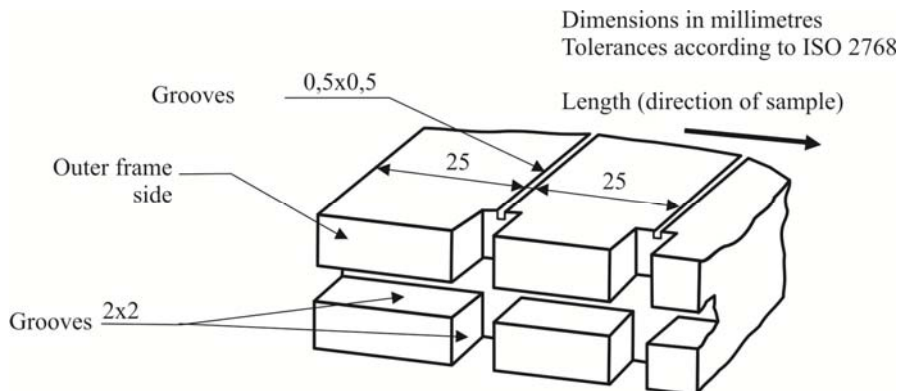

Figure 20
Example of section of lower U-frame design for wire support facility



10.4.6. Stop-watch, accurate to 0.5 sec.

10.4.7. Fume cupboard

The combustion chamber may be placed in a fume-cupboard assembly provided that the latter's internal volume is at least 20 times, but not more than 110 times, greater than the volume of the combustion chamber and provided that no single height, width, or length dimension of the fume cupboard is greater than 2.5 times either of the other two dimensions.

Before the test, the vertical velocity of the air through the fume cupboard shall be measured 100 mm forward of and to the rear of the ultimate site of the combustion chamber. It shall be between 0.10 and 0.30 m/s in order to avoid possible discomfort to the operator from combustion products. It is possible to use a fume cupboard with natural ventilation and an appropriate air velocity.

10.5. Samples

10.5.1. Shape and dimensions

The shape and dimensions of samples are given in **Figure 21**. The thickness of the sample corresponds to the thickness of the product to be tested. It shall not be more than 13 mm. When sample-taking so permits, the sample shall have a constant section over its entire length. When the shape and dimensions of a product do not permit taking a sample of the given size, the following minimum dimensions shall be observed:

- (a) For samples having a width of 3 to 60 mm, the length shall be 356 mm. In this case the material is tested over the product's width;
- (b) For samples having a width of 60 to 100 mm, the length shall be at least 138 mm. In this case the potential burning distance corresponds to the length of the sample, the measurement starting at the first measuring point;
- (c) Samples less than 60 mm wide and less than 356 mm long, and samples 60 to 100 mm wide and less than 138 mm long, cannot be tested according to the present method, nor can samples less than 3 mm wide.

Figure 21
Sample

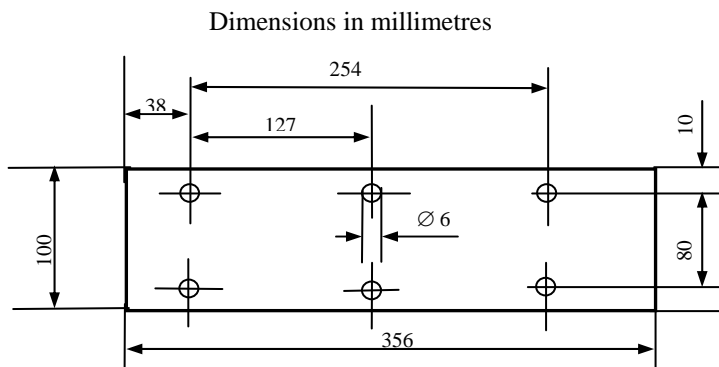

10.5.2. Sampling

At least five samples shall be taken from the material under test. In materials having burning rates differing according to the direction of the material (this being established by preliminary tests) the five (or more) samples shall be taken and be placed in the test apparatus in such a way that the highest burning rate will be measured.

When the material is supplied in set widths, a length of at least 500 mm covering the entire width shall be cut. From the piece so cut, the samples shall be taken at not less than 100 mm from the edge of the material and at points equidistant from each other.

Samples shall be taken in the same way from finished products when the shape of the product so permits. If the thickness of the product is over 13 mm it shall be reduced to 13 mm by a mechanical process applied to the side which does not face the passenger compartment.

Composite materials (see paragraph 10.2.2.) shall be tested as if they were homogeneous.

In the case of materials comprising superimposed layers of different composition which are not composite materials, all the layers of material included within a depth of 13 mm from the surface facing towards the passenger compartment shall be tested individually.

10.5.3. Conditioning

The samples shall be conditioned for at least 24 hours, but not more than 7 days, at a temperature of $23\text{ °C} \pm 2\text{ °C}$ and a relative humidity of 50 ± 5 per cent, and shall be maintained under these conditions until immediately prior to testing.

10.6. Procedure

10.6.1. Place samples with napped or tufted surfaces on a flat surface, and comb twice against the nap using the comb (paragraph 10.4.5.).

10.6.2. So place the sample in the sample holder (paragraph 10.4.2.) that the exposed side faces downwards, towards the flame.

10.6.3. Adjust the gas flame to a height of 38 mm using the mark in the chamber, the air intake of the burner being closed. The flame shall burn for at least one minute, for stabilization, before the first test is started.

10.6.4. Push the sample holder into the combustion chamber so that the end of the sample is exposed to the flame, and after 15 seconds cut off the gas flow.

10.6.5. Measurement of burning time starts at the moment when the foot of the flame passes the first measuring point. Observe the flame propagation on the side (upper or lower) which burns faster.

10.6.6. Measurement of burning time is completed when the flame has come to the last measuring point or when the flame is extinguished before reaching that point. If the flame does not reach the last measuring point, measure the burnt distance up to the point where the flame was extinguished. Burnt distance is the part of the sample destroyed, on the surface or inside, by burning.

- 10.6.7. If the sample does not ignite or does not continue burning after the burner has been extinguished, or the flame goes out before reaching the first measuring point, so that no burning time is measured, note in the test report that the burning rate is 0 mm/min.
- 10.6.8. When running a series of tests or performing repeat tests, make sure before starting a test that the temperature of the combustion chamber and sample holder does not exceed 30 °C.
- 10.7. Calculation
- The burning rate B, in millimetres per minute, is given by the formula:
- $$B = s/t \times 60;$$
- where:
- s is the burnt distance, in millimetres,
- t is the time, in seconds, taken to burn the distance s.
- 10.8. Indices of difficulty of the secondary characteristics
- No secondary characteristics are involved.
- 10.9. Interpretation of results
- 10.9.1. Safety glazing faced with plastics material (paragraph 2.4. of this Regulation) and glass-plastics (paragraph 2.5. of this Regulation) shall be considered satisfactory from the point of view of the fire-resistance test if the burn rate does not exceed 90 mm/min.
- 10.9.2. Rigid plastic panes (paragraph 2.6.1. of this Regulation), flexible plastic panes (paragraph 2.6.2. of this Regulation) and rigid plastic double glazed units shall be considered satisfactory from the point of view of the fire resistance test if the burn rate does not exceed 110 mm/min."
11. Test of resistance to chemicals
- 11.1. Chemicals used for the test
- 11.1.1. Non-abrasive soap solution: 1 per cent by weight of potassium oleate in deionised water;
- 11.1.2. Window-cleaning-solution: an aqueous solution of isopropanol and dipropylene glycol monomethyl ether in concentration between 5 and 10 per cent by weight each and ammonium hydroxide in concentration between 1 and 5 per cent by weight;
- 11.1.3. Undiluted denatured alcohol: 1 part by volume methyl alcohol in 10 parts by volume ethyl alcohol;
- 11.1.4. Petrol or equivalent reference petrol: a mixture of 50 per cent by volume toluene, 30 per cent by volume 2,2,4-trimethylpentane, 15 per cent by volume 2,4,4-trimethyl-1-pentene and 5 per cent by volume ethyl alcohol:
- N.B. The composition of the petrol used shall be recorded in the test report;
- 11.1.5. Reference kerosene: a mixture of 50 per cent by volume n-octane and 50 per cent by volume n-decane.

11.2. Test method

11.2.1. Immersion test

Four samples 180 mm x 25 mm shall be tested for each test and each chemical specified in paragraph 11.1. above, using a new test piece for each test and each cleaning product.

Before each test, samples shall be cleaned according to the manufacturer's instructions, then conditioned for 48 hours at a temperature of $23\text{ }^{\circ}\text{C} \pm 2\text{ }^{\circ}\text{C}$ and a relative humidity of 50 ± 5 per cent. These conditions shall be maintained throughout the tests.

The samples shall be completely immersed in the test fluid and held for one minute, then removed and immediately wiped dry with a clean absorbent cotton cloth.

11.2.2. Indices of difficulty of the secondary characteristics

	Colourless	Tinted
Colouring of the interlayer or of the plastics coating	2	2

The other secondary characteristics are not concerned.

11.2.3. Interpretation of results

11.2.3.1. The test for resistance to chemical agents shall be considered to have given a satisfactory result if the sample does not exhibit any softening, tackiness, crazing or apparent loss of transparency.

11.2.3.2. A set of samples shall be considered satisfactory with regard to the test for resistance to chemical agents if at least three of the four tests carried out with each chemical have given a satisfactory result.

11.2.4. Test procedure under load

11.2.4.1. The sample shall be simply supported as a horizontal level arm between a fixed supporting edge at one end in such a way that the entire width will rest on a cutting edge (fulcrum) which is 51 mm from the fixed end support. A load shall be suspended from the free end of the test specimen at a distance of 102 mm from the fulcrum as shown in Figure 22 below:

Figure 22

Method of setting up the sample

Unit: mm

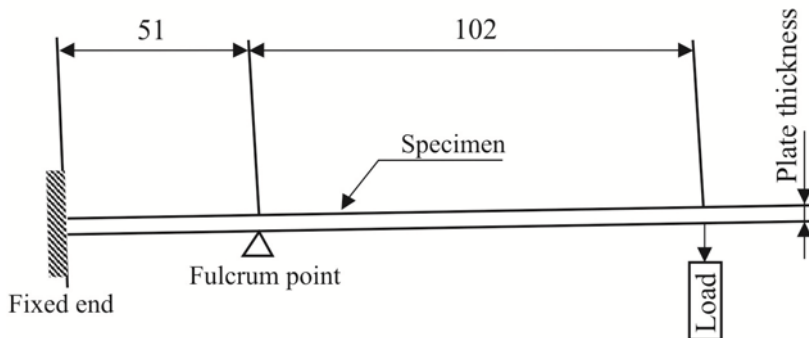

11.2.4.2. The load mass shall be $28.7 \cdot t^2$ g where t is the thickness in mm of the test specimen. The resulting stress on the outer fibre of the sample is approximately 6.9 MPa.

Example: For a 3 mm thick sample placed horizontally between a downward fixed edge and an upward fulcrum edge separated by 51 mm the applied downward load at 102 mm from the fulcrum is to be 258 g.

11.2.4.3. While the sample is stressed, one of the prescribed chemicals shall be applied to the top surface of the sample above the fulcrum point. The chemical shall be applied with a soft, 13 mm wide brush, wetted before each stroke. Ten individual strokes at 1 s intervals across the width of the sample, avoiding the end and edges, shall be required (see Figure 23).

Figure 23

Method of applying chemicals to the sample

Unit: mm

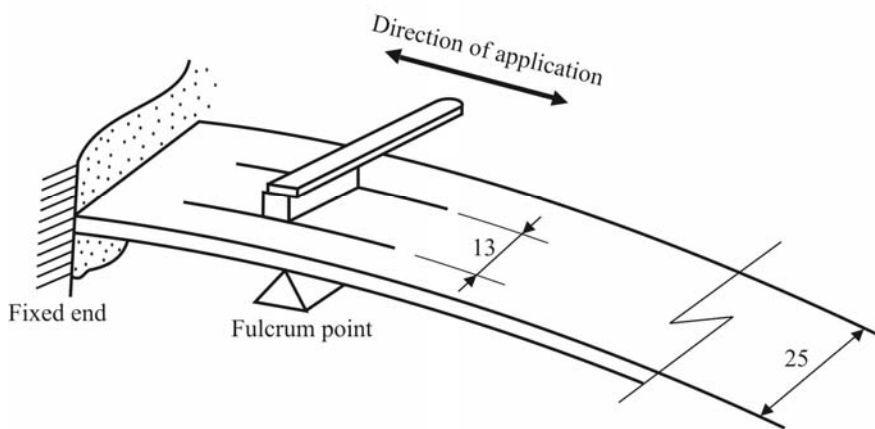

11.2.5. Indices of difficulty of the secondary characteristics

	Colourless	Tinted
Colouring of the plastics coating or plastic glazing	1	2

The other secondary characteristics are not concerned.

11.2.6. Interpretation of results

11.2.6.1. The test for resistance to chemical agents shall be considered to have given a satisfactory result if the sample does not exhibit any softening, tackiness, crazing or apparent loss of transparency.

11.2.6.2. A set of samples shall be considered satisfactory with regard to the test for resistance to chemical agents if one of the following conditions is met:

11.2.6.2.1. All the tests have given a satisfactory result;

11.2.6.2.2. One test having given an unsatisfactory result, a new series of tests carried out on a new set of samples has given a satisfactory result.

12. Flexibility test and fold test

12.1. Scope

With this test has to be found out whether a plastic is to be classed into the categories of rigid or flexible plastics.

12.2. Test method

From the material of the nominal thickness a rectangular flat sample 300 mm long and 25 mm wide is cut out and horizontally clamped into a clamping device in such a way that 275 mm of the length of the sample freely extend over the holding device. This free end shall be supported horizontally by an appropriate device until the test begins. Sixty seconds after removal of this support the vertical deviation of the free end is indicated in mm. If this deviation exceeds 50 mm a 180° fold test is performed subsequently. The sample is folded concisely, after that it is folded round 0.5 mm thick piece of sheet metal in such a way that it tightly contacts it on both sides.

12.3. Test conditions

Temperature: 20 °C ± 2 °C

Relative humidity: 60 ± 5 per cent

12.4. Requirements

The vertical deviation shall be more than 50 mm for flexible plastics, and 10 seconds after a 180° - folding the material shall not show any fracture-like damages at the point of buckling (see Figure 24).

13. Cross-cut test

13.1. Scope

This test gives a simple method to determine the adhesion of coatings to the subsurface. The brittleness and other strength characteristics can be evaluated.

13.2. Apparatus

Cutting tool with 6 blades set at 1 mm apart. A magnifying glass with an enlargement of 2 x to examine the crosscut specimen (see Figure 25).

Figure 24
Arrangement of flexibility test

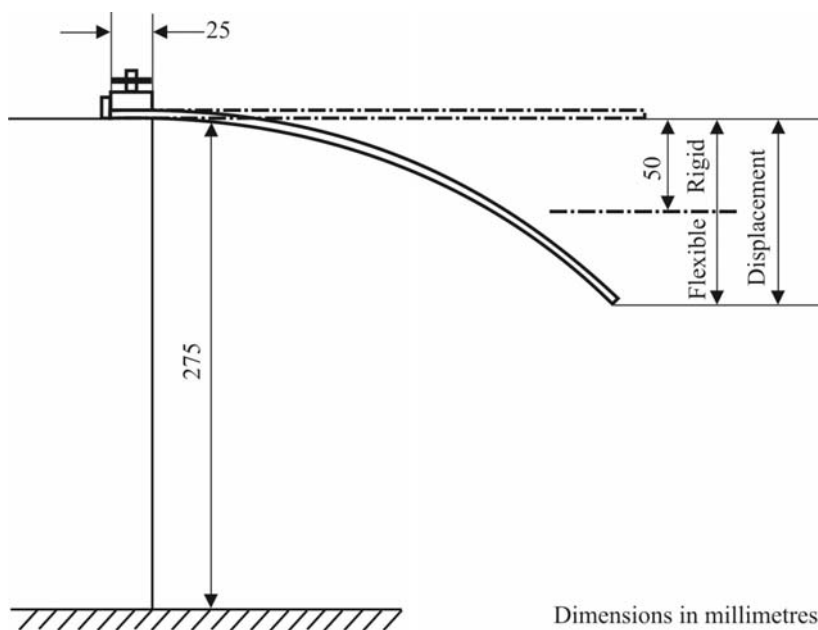
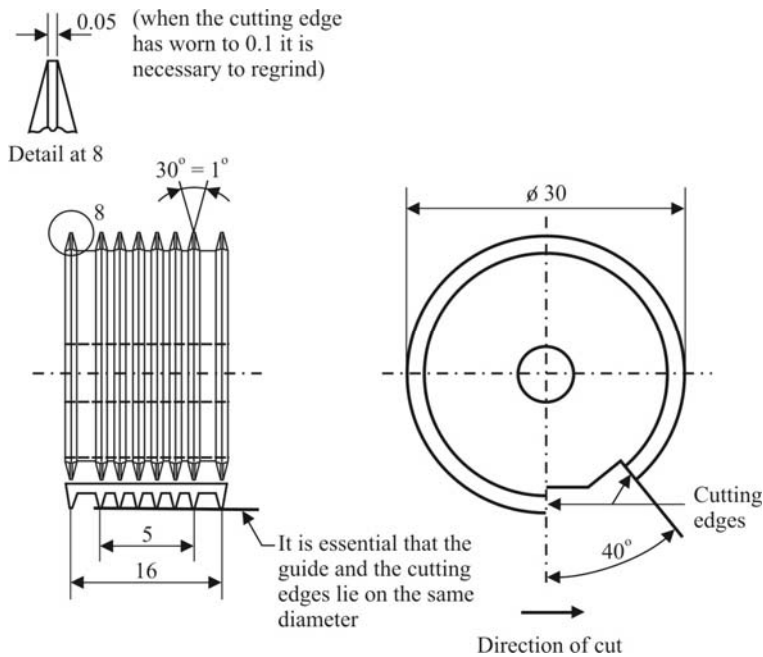

Figure 25

Tool with six blades



13.3. Test Method

Cut through the coating on to the subsurface a pattern with 6 cuts and perpendicular to this, another one so that a grid with 25 squares arises (grid-cut).

The cutting tool should be drawn steadily with a speed of 2 to 5 cm/s so that the cuts reach the subsurface but do not penetrate too deeply.

The cutting is conducted in such a way that the two leading heads at the edge of the apparatus touch the surface uniformly. After the test the cuts are examined with a magnifying glass to check that they reach the subsurface. The test is carried out at least at two different positions of the sample. After the cuts have been produced they are brushed 5 times with slight pressure in both diagonal directions with a hand brush with polyamide bristles.

13.4. Interpretation of results

The grid cuts are examined with a magnifying glass. If the cut edges are perfectly smooth and if no part of the coating is detached then it will be given a cross cut value of Gt0. If there are small fragments detached at the intersection of the cuts and if the exposed area amounts to about 5 per cent of the grid area the cut value is Gt1.

Larger areas of detachment will be graded in the range Gt2 to Gt5.

<i>Cut value grade</i>	<i>Exposed area of the grid area</i>
Gt2	between 5 and 15 per cent
Gt3	between 15 and 35 per cent
Gt4	between 35 and 65 per cent
Gt5	higher than 65 per cent

II. Justification:

Sensors and cameras e.g. rain-light sensors, distance and lane control sensors, collision warning systems, IR-cameras etc. to improve driving safety mainly get placed in the driver's field of view respectively in the wiped area of windcreens.

Excluded areas from the main vision zone to allow the application of these systems are well defined for M1 vehicles and have been in place for years.

Depending on the R-point of the vehicle and the windscreen installation angle of M1-vehicles the distances between the upper edges of zone A and B (plane 1, annex 18, para. 2.2. and plane 5, annex 18, para. 2.3.) varies approximately from **65 to 117** mm measured on the outer surface of the windcreens (basis for this estimation are forty M1 vehicles, small size, middle class, upper class and SUVs). Laterally this area is limited in many cases by max. 300 mm.

The draft proposal is to define an excluded area for vehicles of categories M and N other than M1.

The proposed angle of 5° (proposed annex 3, para. 9.2.5.3.1.) to define an area analogical to the above will lead to a range in the distances p3-p5 on CL (see Figure 11) of approximately **50 – 85** mm (basis for this estimation are 10 trucks and a bus with windscreen inclination angles of 7,2°-31°). Laterally the limit is set at 300 mm.