

GRPE non-harmonized definitions

Contents

ADJUSTMENT FACTORS (GRPE).....	2
APPROVAL OF AN ENGINE FAMILY (GRPE).....	3
BI-FUEL VEHICLE (GRPE).....	3
COLD START DEVICE (GRPE).....	3
CONTINUOUS REGENERATION (GRPE).....	3
DELAY TIME (GRPE).....	3
DRIFT (GRPE).....	4
DRIVING CYCLE (GRPE).....	4
ELECTRIC POWER TRAIN (GRPE, GRSP).....	4
ELECTRONIC CONTROL UNIT (GRSG, GRPE).....	4
EMISSION CONTROL STRATEGY “ECS” (GRPE).....	4
EMISSION CONTROL SYSTEM (GRPE).....	4
ENGINE CRANKCASE (GRPE).....	5
ENGINE FAMILY (GRPE).....	5
EXHAUST AFTERTREATMENT SYSTEM (GRPE).....	5
FULL FLOW DILUTION METHOD (GRPE).....	5
GASEOUS POLLUTANTS (GRPE).....	5
HIGH SPEED “n _{hi} ” (GRPE).....	5
HYBRID ELECTRIC VEHICLE “HEV” (GRPE).....	5
HYBRID VEHICLE “HV” (GRPE).....	6
LOW SPEED “n _{lo} ” (GRPE).....	6
MALFUNCTION (GRPE).....	6
MALFUNCTION INDICATOR “MI” (GRPE).....	6
MANUFACTURER (GRPE, GRRF, GRSG).....	6
MAXIMUM MASS (GRRF, GRE, GRSG, GRPE).....	7
MAXIMUM SPEED “V _{max} ” (GRB, GRPE, GRRF).....	7
MEMBER OF THE FAMILY (GRPE).....	7
MONO-FUEL VEHICLE (GRPE).....	8
NET POWER (GRPE).....	8
OBD (GRPE).....	10

OPACIMETER (GRPE)	10
ORIGINAL POLLUTION CONTROL DEVICE (GRPE).....	10
PARENT ENGINE (GRPE).....	10
PARENT VEHICLE (GRPE)	10
PARTIAL FLOW DILUTION METHOD (GRPE).....	10
PARTICULATE MATTER “PM” (GRPE).....	11
PARTICULATE POLLUTANTS (GRPE).....	11
PERIODIC REGENERATION (GRPE).....	11
PERIODICALLY REGENERATING SYSTEM (GRPE)	11
POWER TRAIN (GRPE).....	12
RATED SPEED (GRPE)	12
REAGENT (GRPE)	12
REFERENCE MASS (GRPE, GRSP)	12
REFERENCE WEIGHT (GRPE)	12
REPLACEMENT POLLUTION CONTROL DEVICE (GRPE).....	12
RISE TIME (GRPE).....	12
SCAN-TOOL (GRPE)	13
STANDARDIZED (GRPE).....	13
TRANSFORMATION TIME (GRPE)	13
UNLADEN MASS “MV” (GRSG, GRPE, GRRF, GRSP).....	13
USEFUL LIFE (GRPE)	14
VEHICLE (GRSG, GRPE)	14
WARM-UP CYCLE (GRPE).....	14

ADJUSTMENT FACTORS (GRPE)

(UN Reg. 96) mean additive, upward adjustment factor and downward adjustment factor, or multiplicative factors to be considered during the periodic, infrequent, regeneration.

(UN Reg. 132) means additive upward adjustment factor and downward adjustment factor or multiplicative factors to be considered during periodic regeneration.

APPROVAL OF AN ENGINE FAMILY (GRPE)

(UN Reg. 49) means the approval of an engine type, engine family, with regard to the level of the emission of gaseous and particulate pollutants, smoke and the on-board diagnostic, OBD system.

(UN Reg. 96) means the approval of an engine type or family with regard to the level of emission of gaseous and particulate pollutants by the engine.

(UN Reg. 120) means the approval of the members of an engine family with regard to their net power.

BI-FUEL VEHICLE (GRPE)

(UN Reg. 83) means a vehicle with two separate fuel storage systems that is designed to run on only one fuel at a time. The simultaneous use of both fuels is limited in amount and duration.

(UN Reg. 115) when after the retrofit operation, it is equipped with gas storage and separate petrol storage with a capacity exceeding 15 litres, and is designed to run on only one fuel at a time. The simultaneous use of both fuels is limited in amount or duration.

COLD START DEVICE (GRPE)

(UN Reg. 24) means a device which by its operation temporarily increases the amount of fuel supplied to the engine and is intended to facilitate starting of the engine.

(UN Reg. 83) means a device that temporarily enriches the air/fuel mixture of the engine thus assisting the engine to start.

(UN Reg. 84 and 101) means a device which enriches the air/fuel mixture of the engine temporarily, to assist starting.

CONTINUOUS REGENERATION (GRPE)

(UN Reg. 49) means the regeneration process of an exhaust aftertreatment system that occurs either permanently or at least once per World Harmonised Transient Driving Cycle "WHTC" hot start test.

(UN Reg. 96) means the regeneration process of an exhaust aftertreatment system that occurs either in a sustained manner or at least once over the applicable transient test cycle or ramped-modal cycle; in contrast to periodic (infrequent) regeneration.

(UN Reg. 132) means the regeneration process of an exhaust aftertreatment system that occurs either permanently or at least once per applicable test cycle.

DELAY TIME (GRPE)

(UN Reg. 49) means the time between the change of the component to be measured at the reference point and a system response of 10 per cent of the final reading (t_{10}). For the gaseous components, this is basically the transport time of the measured component from the sampling probe to the detector. For the delay time, the sampling probe is defined as the reference point.

(UN Reg. 96) means the difference in time between the change of the component to be measured at the reference point and a system response of 10 per cent of the final reading (t_{10}) with the sampling probe being defined as the reference point. For the gaseous components, this is the transport time of the measured component from the sampling probe to the detector.

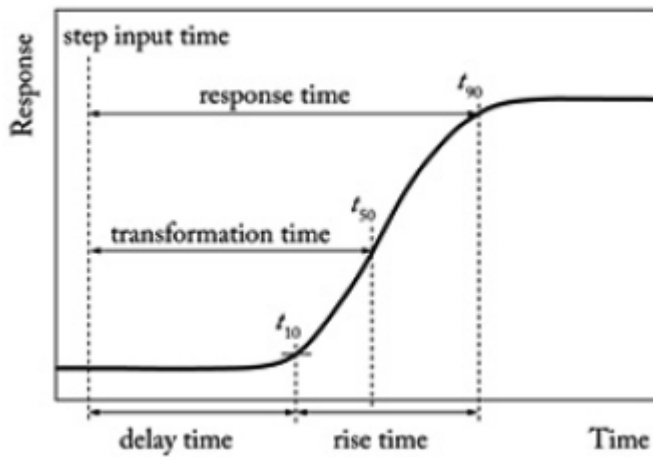

DRIFT (GRPE)

(UN Reg. 96) means the difference between a zero or calibration signal and the respective value reported by a measurement instrument immediately after it was used in an emission test, as long as the instrument was zeroed and spanned just before the test.

(UN Reg. 49) means the difference between the zero or span responses of the measurement instrument after and before an emissions test.

DRIVING CYCLE (GRPE)

(UN Reg. 49) means a sequence consisting of an engine start, an operating period of the vehicle, an engine shut-off, and the time until the next engine start.

(UN Reg. 103) consists of engine start-up, driving mode where a malfunction would be detected if present, and engine shut-off.

ELECTRIC POWER TRAIN (GRPE, GRSP)

(UN Reg. 100) means the electrical circuit which includes the traction motor(s), and may include the RESS, the electric energy conversion system, the electronic converters, the associated wiring harness and connectors, and the coupling system for charging the RESS.

(UN Reg. 101) means a system consisting of one or more electric energy storage devices (e.g. a battery, electromechanical flywheel or super capacitor), one or more electric power conditioning devices and one or more electric machines that convert stored electric energy to mechanical energy delivered at the wheels for propulsion of the vehicle.

ELECTRONIC CONTROL UNIT (GRSG, GRPE)

(UN Reg. 67) means a device which controls the LPG demand of the engine and cuts off automatically the power to the shut-off valves of the LPG-system in case of a broken fuel supply pipe caused by an accident, or by stalling of the engine.

(UN Reg. 96) means an engine's electronic device that uses data from engine sensors to control engine parameters.

EMISSION CONTROL STRATEGY "ECS" (GRPE)

(UN Reg. 49) means an element or set of elements of design that is incorporated into the overall design of an engine system or vehicle for the purposes of controlling exhaust emissions that includes one BECS and one set of AECS.

(UN Reg. 96) means a combination of an emission control system with one base emission control strategy and with one set of auxiliary emission control strategies, incorporated into the overall design of an engine or non-road mobile machinery into which the engine is installed.

EMISSION CONTROL SYSTEM (GRPE)

(UN Reg. 49) means the elements of design and emission strategies developed or calibrated for the purpose of controlling emissions.

(UN Reg. 96) means any device, system, or element of design that controls or reduces the emissions of regulated pollutants from an engine.

(UN Reg. 103) means the electronic engine management controller and any emission-related component in the exhaust or evaporative system which supplies an input to or receives an output from this controller.

ENGINE CRANKCASE (GRPE)

(UN Reg. 40) means the spaces in or external to an engine which are connected to the oil sump by internal or external ducts through which gases and vapours can escape.

(UN Reg. 83) means the spaces in or external to an engine which are connected to the oil sump by internal or external ducts through which gases and vapour can escape.

ENGINE FAMILY (GRPE)

(UN Reg. 49 and 96) means a manufacturer's grouping of engines which through their design have similar exhaust emission characteristics.

(UN Reg. 120) means a manufacturer's grouping of engines which, through their design, fulfil the grouping criteria laid down in the essential characteristics of the engine family.

(UN Reg. 132) means an engine manufacturer's grouping of engine systems which, through their design, have similar exhaust emission characteristics; all members of the family shall comply with the applicable emission limit values.

EXHAUST AFTERTREATMENT SYSTEM (GRPE)

(UN Reg. 49) means a catalyst, oxidation, 3-way or any other, particulate filter, deNOx system, combined deNOx particulate filter, or any other emission reducing device, that is installed downstream of the engine.

(UN Reg. 96) means a catalyst, particulate filter, deNOx system, combined deNOx particulate filter or any other emission-reducing device that is installed downstream of the engine. This definition excludes exhaust gas recirculation "EGR" and turbochargers, which are considered an integral part of the engine.

FULL FLOW DILUTION METHOD (GRPE)

(UN Reg. 96) means the process of mixing the total exhaust flow with dilution air prior to separating a fraction of the diluted exhaust stream for analysis.

(UN Reg. 49) means the process of mixing the total exhaust flow with diluent prior to separating a fraction of the diluted exhaust stream for analysis.

GASEOUS POLLUTANTS (GRPE)

(UN Reg. 40, 47 and 96) means carbon monoxide, hydrocarbons (assuming a ratio of $C_1H_{1.85}$) and oxides of nitrogen, the last named being expressed in nitrogen dioxide (NO_2) equivalent.

(UN Reg. 49) means the exhaust gas emissions of carbon monoxide, NO_x , expressed in NO_2 equivalent, hydrocarbons.

(UN Reg. 83) means the exhaust gas emissions of carbon monoxide, oxides of nitrogen expressed in nitrogen dioxide " NO_2 " equivalent and hydrocarbons assuming ratio of:

- $C_1H_{2.525}$ for liquefied petroleum gas "LPG".
- C_1H_4 for natural gas "NG" and biomethane
- $C_1H_{1.89}O_{0.016}$ for petrol "E5"
- $C_1H_{1.86}O_{0.005}$ for diesel "B5"
- $C_1H_{2.74}O_{0.385}$ for ethanol "E85"
- $C_1H_{2.61}O_{0.329}$

(UN Reg. 132) means carbon monoxide, hydrocarbons (assuming a ratio of $CH_{1.85}$ for diesel), oxides of nitrogen (NO_x , expressed as NO_2 equivalent) and nitrogen dioxide (NO_2).

HIGH SPEED " n_{hi} " (GRPE)

(UN Reg. 49) means the highest engine speed where 70 per cent of the declared maximum power occurs.

(UN Reg. 96) means the highest engine speed where 70 per cent of the maximum power occurs.

HYBRID ELECTRIC VEHICLE "HEV" (GRPE)

(UN Reg. 24, 83 and 85) means a vehicle that, for the purpose of mechanical propulsion, draws energy from both of the following on-vehicle sources of stored energy/power:

- A consumable fuel.
- An electrical energy/power storage device.

(UN Reg. 101) means a vehicle powered by a hybrid electric power train.

HYBRID VEHICLE “HV” (GRPE)

(UN Reg. 24, 83 and 85) means a vehicle with at least two different energy converters and two different energy storage systems, on vehicle, for the purpose of vehicle propulsion.

(UN Reg. 101) means a vehicle powered by a hybrid power train.

LOW SPEED “n_{lo}” (GRPE)

(UN Reg. 49) means the lowest engine speed where 55 per cent of the declared maximum power occurs.

(UN Reg. 96) means the lowest engine speed where 50 per cent of the maximum power occurs.

MALFUNCTION (GRPE)

(UN Reg. 49) means a failure or deterioration of an engine system, including the OBD system, that might reasonably be expected to lead either to an increase in any of the regulated pollutants emitted by the engine system or to a reduction in the effectiveness of the OBD system.

(UN Reg. 103) means the failure of an emission-related component or system that would result in emissions exceeding the limits in the table below, or if the OBD system is unable to fulfil the basic monitoring requirements.

Category	Class	Reference mass (RW) (kg)	Mass of carbon monoxide (CO) (mg/km)		Mass of non-methane hydrocarbons (NMHC) (mg/km)	
			PI	CI	PI	CI
M	-	All	1900	1900	250	320
N ₁ ¹	I	RW ≤ 1305	1900	1900	250	320
	II	1305 < RW ≤ 1760	3400	2400	330	360
	III	1760 < RW	4300	2800	400	400
N ₂	-	All	4300	2800	400	400

Key: PI = Positive Ignition, CI = Compression Ignition

1- Includes M₁ vehicles that meet the “special social needs” definition.

Category	Class	Reference mass (RW) (kg)	Mass of oxides of nitrogen (NO _x) (mg/km)		Mass of particulates (PM) (mg/km)	
			PI	CI	PI ²	CI ²
M	-	All	300	540	50	50
N ₁ ³	I	RW ≤ 1305	300	540	50	50
	II	1305 < RW ≤ 1760	375	705	50	50
	III	1760 < RW	410	840	50	50
N ₂	-	All	410	840	50	50

Key: PI = Positive Ignition, CI = Compression Ignition

standards apply only to vehicles with direct injection engines.

2- Positive ignition particulate mass stan-

3- PM threshold limit of 80 mg/km shall

apply to vehicles of categories M and N with a reference mass greater than 1,760 kg.

MALFUNCTION INDICATOR “MI” (GRPE)

(UN Reg. 49) means an indicator which is part of the alert system and which clearly informs the driver of the vehicle in the event of a malfunction.

(UN Reg. 103) means a visible or audible indicator that clearly informs the driver of the vehicle in the event of a malfunction of any emission-related component connected to the OBD system, or the OBD system itself.

MANUFACTURER (GRPE, GRRF, GRSG)

(UN Reg. 49) means the person or body who is responsible to the approval authority for all aspects of the type-approval or authorisation process and for ensuring conformity of production. It is not essential that the person or body be directly involved in all stages of the construction of the vehicle, system, component or separate technical unit which is the subject of the approval process.

(UN Reg. 90) means the organization which can assume technical responsibility for the brake lining assemblies or drum brake linings or brake drums and discs and can demonstrate that it possesses the necessary means to achieve conformity of production.

(UN Reg. 116, 118, 121, 122 and RE3) means the person or body who is responsible to the approval authority for all aspects of the type approval process and for ensuring conformity of production. It is not essential that the person or body is directly involved in all stage of the construction of the vehicle, system, component or separate technical unit which is the subject of the approval process.

(UN Reg. 132) means the person or body who is responsible to the Type Approval Authority for all aspects of the type-approval and can demonstrate that it possesses the features required and the necessary means to achieve quality assessment and conformity of production. It is not essential that the person or body be directly

involved in all stages of the construction of the vehicle, system, component or separate technical unit which is the subject of the approval process.

MAXIMUM MASS (GRRF, GRE, GRSG, GRPE)

(UN Reg. 13, 13H, 58 and 64) means the maximum mass stated by the vehicle manufacturer to be technically permissible. This mass may be higher than the “permissible maximum mass” laid down by the national administration.

(UN Reg. 50, 53, 78 and 113) see “Gross vehicle mass” definition.

(UN Reg. 51, 83 and 84) means the technically permissible maximum mass declared by the vehicle manufacturer. This mass may be greater than the maximum mass authorized by the national administration.

(UN Reg. 73 and 93) means the mass stated by the vehicle manufacturer to be technically permissible. This mass may be higher than the “permissible maximum mass” laid down by the national administration.

(UN Reg. 101) means the technically permissible maximum mass declared by the manufacturer. This mass may be greater than the maximum mass authorized by the national administration.

(UN Reg. 111) means the technically permissible maximum mass stated by the vehicle manufacturer. This mass may be higher than the “permissible maximum mass” laid down by the national administration.

MAXIMUM SPEED “V_{max}” (GRB, GRPE, GRRF)

(UN Reg. 41) means the maximum vehicle speed as defined in ISO 7117:1995. The symbol V_{max} denotes the maximum speed.

(UN Reg. 68) means:

- For thermal engine driven vehicles, the maximum steady speed.
- For electric vehicles, the highest average value of the speed, which the vehicle can maintain twice over a distance of 1 km.

(UN Reg. 89) is the maximum speed reached by the vehicle in the first half of the period of the response curve.

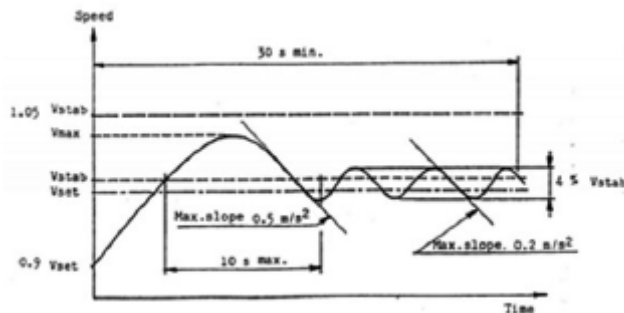

MEMBER OF THE FAMILY (GRPE)

(UN Reg. 83) is a vehicle that shares the following essential characteristics with its parent(s):

- It is produced by the same manufacturer;
- It is subject to the same emission limits;
- If the gas fuelling system has a central metering for the whole engine:
 - i. It has a certified power output between 0.7 and 1.15 times that of the parent vehicle.
 - ii. If the gas fuelling system has an individual metering per cylinder: It has a certified power output per cylinder between 0.7 and 1.15 times that of the parent vehicle.
- If fitted with a catalyst, it has the same type of catalyst i.e. three way, oxidation, de-NOx.
- It has a gas fuelling system (including the pressure regulator) from the same system manufacturer and of the same type: induction, vapour injection (single point, multipoint), liquid injection (single point, multipoint).
- This gas fuelling system is controlled by an ECU of the same type and technical specification, containing the same software principles and control strategy. The vehicle may have a second ECU compared to the parent vehicle, provided that the ECU is only used to control the injectors, additional shut-off valves and the data acquisition from additional sensors.

(UN Reg. 115) The family definition is based on the original vehicle characteristics. It is a vehicle sharing the following essential characteristics with its parent vehicle:

- It is produced by the same vehicle manufacturer.
- It is classified in the same category M₁ or M₂ or M₃ or N₁ or N₂ or N₃. Vehicles of category M₁ and N₁ class I may belong to the same family.
- It is subject to the same emission limits or those specified in earlier series of amendments of the applicable Regulation.
- If the gas fuelling system has a central metering for the whole engine: it has an approved power output between 0.7 and 1.15 times that of the engine of the parent vehicle. If the gas fuelling system as an individual metering per cylinder: it has an approved power output per cylinder between 0.7 and 1.15 times that of the engine of the parent vehicle.

- Fuel feed and combustion process (injection: direct or indirect, single-point or multi-point).

- It has the same pollution control system:

- iii. Same type of catalyst if fitted (three-way, oxidation, DeNO_x)

- iv. Air injection (with or without)

- v. Exhaust gas recirculation (EGR) (with or without)

If the tested vehicle was not equipped with air-injection or EGR, engines with these devices are allowed.

With regard to the requirement that it is produced by the same vehicle manufacturer, the vehicle family can also cover vehicles produced by other vehicle manufacturers if it can be demonstrated to the type approval authority that the same engine type and emission strategy is used.

With regard to requirement that the gas fuelling system has a central metering for the whole engine:

- In the case of a central metering for the whole vehicle where a demonstration shows that two gas fuelled vehicles could be members of the same family with the exception of their approved power output, respectively P1 and P2 ($P1 < P2$), and both are tested as if they were parent vehicles, the family relation will be considered valid for any vehicle with an approved power output between $0.7 \cdot P1$ and $1.15 \cdot P2$;

- In the case of an individual metering per cylinder where a demonstration shows two gas fuelled vehicles could be members of the same family with the exception of their approved power output, respectively P1 and P2 ($P1 < P2$), and both are tested as if they were parent vehicles, the family relation will be considered valid for any vehicle with an approved power output between $0.7 \cdot P1$ and $1.15 \cdot P2$.

With regard to the requirement that has the same pollution control system, in case of a “master-slave” system, the family relation will be considered valid regardless of the presence of the air injection or the EGR.

MONO-FUEL VEHICLE (GRPE)

(UN Reg. 83) means a vehicle that is designed to run primarily on one type of fuel.

(UN Reg. 115) when, after the retrofit operation, it is designed primarily for permanent running on LPG or CNG, but may still have a petrol system for emergency purposes, where the capacity of the petrol tank does not exceed 15 litres.

NET POWER (GRPE)

(UN Reg. 24) means the power of a compression ignition engine.

(UN Reg. 49) means the power obtained on a test bench at the end of the crankshaft or its equivalent at the corresponding engine or motor speed with the auxiliaries and determined under reference atmospheric conditions.

(UN Reg. 85) means the power obtained on a test bench at the end of the crankshaft or its equivalent at the corresponding engine or motor speed with the auxiliaries listed in the table below, and determined under reference atmospheric conditions.

No.	Auxiliaries	Fitted for net power and the maximum 30 minutes power test
1	Stabilized DC power supply	Voltage drop during test less than 5 %
2	Speed variation and control device	Yes: Standard-production equipment
3	LIQUID-COOLING Motor bonnet Bonnet outlet Radiator ^{1/2} Fan Fan cowl Pump Thermostat ³	No Yes: Standard-production equipment
4	Electric equipment	Yes: Standard-production equipment
5	Bench test auxiliary fan	Yes, if necessary

1 The radiator, the fan, the fan cowl, the water pump and the thermostat shall be located on the test bench in the same relative position as on the vehicle. The cooling-liquid circulation shall be activated by the drive train water pump only.

Cooling of the liquid may be produced either by the drive train radiator, or by an external circuit, provided that the pressure loss of this circuit and the pressure at the pump inlet remain substantially the same as those of the drive train cooling system. The radiator shutter, if any, shall be in the open position.

Where the fan, radiator and fan cowl cannot conveniently be fitted for the bench test, the power absorbed by the fan when separately mounted in its correct position in relation to the radiator and cowl (if used), shall be determined at the speed corresponding to the motor speeds used for measurement of the motor power either by calculation from standard characteristics or by practical tests. This power, corrected to the standard atmospheric conditions should be deducted from the correct power.

2 Where a disconnectable or progressive fan or blower is incorporated, the test should be carried out with the disconnectable fan (or blower) disconnected or at maximum slip condition.

3 The thermostat may be fixed in the fully open position.

(UN Reg. 96) means the power in “ECE kW” obtained on the test bench at the end of the crankshaft, on the measurement of the net power, net torque and specific fuel consumption of internal combustion engines for agricultural and forestry tractors and non-road mobile machinery.

(UN Reg. 120) means the power obtained on a test bench at the end of the crankshaft or its equivalent at the corresponding engine speed with the auxiliaries and equipment listed in the table below, determined under reference atmospheric conditions.

Number	Equipment and auxiliaries	Fitted for emission test
1	Inlet system	Yes
	Inlet manifold	Yes
	Crankcase emission control system	Yes
	Air flow meter	Yes ^a
	Air filter	Yes ^b
	Inlet silencer	Yes ^b
2	Induction-heating device of inlet manifold	Yes, standard production equipment. If possible to be set in the most favourable condition
	Exhaust system	Yes, standard production equipment
	Exhaust aftertreatment	Yes, standard production equipment
	Exhaust manifold	Yes ^b
	Connecting pipes	Yes ^b
	Silencer	Yes ^b
3	Tail pipe	No ^c
	Exhaust brake	Yes
4	Pressure charging device	Yes
	Fuel supply pump	Yes
	Carburetion equipment	Yes
	Carburetor	Yes
	Electronic control system, air flow meter, etc.	Yes
	Equipment for gas engines	Yes
5	Pressure reducer	Yes
	Evaporator	Yes
	Mixer	Yes
	Fuel injection equipment (petrol and diesel)	Yes
	Pre-filter	Yes
	Filter	Yes
6	Pump	Yes
	High-pressure pipe	Yes
	Injector	Yes
	Electronic control system, sensors, etc.	Yes
	Governer/control system	Yes
	Automatic full-load stop for the control rack depending on atmospheric conditions	Yes
7	Liquid-cooling equipment	Yes
	Radiator	No
	Fan	No
	Fan cowl	No
	Water pump	Yes ^f
	Thermostat	Yes ^f

7	Air cooling	No ^g
	Cowl	No ^g
	Fan or Blower	No
8	Temperature-reducing device	No
	Electrical equipment	Yes ^h
	Generator	Yes
	Spark distribution system	Yes
	Coil or coils	Yes
	Wiring	Yes
9	Spark plugs	Yes
	Electronic control system including knock sensor/spark retard system	Yes
	Pressure charging equipment	Yes
	Compressor driven either directly by the engine and/or by the exhaust gases	Yes ^{i,j}
10	Charge air cooler	Yes
	Coolant pump or fan (engine-driven)	Yes ^k
11	Coolant flow control device	No ^l
		Yes
12	Auxiliary test-bed fan	Yes, if necessary
13	Anti-pollution device	Yes, standard production equipment ^l
14	Starting equipment	Yes or test bed equipment ^k
15	Lubricating oil pump	Yes

a The complete inlet system shall be fitted as provided for the intended application:

- Where there is a risk of an appreciable effect on the engine power.
- In the case of naturally aspirated spark ignition engines.
- When the manufacturer requests that this should be done.

In other cases, an equivalent system may be used and a check should be made to ascertain that the intake pressure does not differ by more than 100 Pa from the upper limit specified by the manufacturer for a clean air filter.

b The complete exhaust system shall be fitted as provided for the intended application:

- Where there is a risk of an appreciable effect on the engine power.
- In the case of naturally aspirated spark ignition engines.
- When the manufacturer requests that this should be done.

In other cases, an equivalent system may be installed provided the pressure measured does not differ by more than 1,000 Pa from the upper limit specified by the manufacturer.

c If an exhaust brake is incorporated in the engine, the throttle valve shall be fixed in the fully open position.

d The fuel feed pressure may be adjusted, if necessary, to reproduce the pressure existing in the particular engine application (particularly when a "fuel return" system is used).

e The cooling-liquid circulation shall be operated by the engine water pump only. Cooling of the liquid may be produced by an external circuit, such that the pressure loss of this circuit and the pressure at the pump inlet remain substantially the same as those of the engine cooling system.

f The thermostat may be fixed in the fully open position.

g When the cooling fan or blower is fitted for the test, the power absorbed shall be added to the results, except for engines where such auxiliaries are an integral part of the engine (i.e.: cooling fans of air cooled engines

directly fitted on the crankshaft). The fan or blower power shall be determined at the speeds used for the test either by calculation from standard characteristics or by practical tests.

h Minimum power of the generator: the electrical power of the generator shall be limited to that necessary for operation of auxiliaries which are indispensable for engine operation. If the connection of a battery is necessary, a fully charged battery in good condition shall be used.

i Charge air-cooled engines shall be tested with charge air cooling, whether liquid- or air-cooled, but if the manufacturer prefers, a test bench system may replace the air cooler. In either case, the measurement of power at each speed shall be made with the maximum pressure drop and the minimum temperature drop of the engine air across the charge air cooler on the test bench system as those specified by the manufacturer.

j These may include, for example, exhaust-gas recirculation (EGR system), catalytic converter, thermal reactor, secondary air-supply system and fuel evaporation protecting system.

k The power for electrical or other starting systems shall be provided from the test bed.

OBD (GRPE)

(UN Reg. 49) means an on-board diagnostic system for emission control, which has the capability of detecting the occurrence of a malfunction and of identifying the likely area of malfunction by means of fault codes stored in computer memory.

(UN Reg. 83) means an on-board diagnostic system for emission control, which has the capability of identifying the likely area of malfunction by means of fault codes stored in computer memory.

(UN Reg. 103) means an on-board diagnostic system for emission control which shall have the capability of identifying the likely area of malfunction by means of fault codes stored in computer memory.

OPACIMETER (GRPE)

(UN Reg. 24) means an instrument for continuous measurement of the light absorption coefficients of the exhaust gases emitted by vehicles.

(UN Reg. 49) means an instrument designed to measure the opacity of smoke particles by means of the light extinction principle.

ORIGINAL POLLUTION CONTROL DEVICE (GRPE)

(UN Reg. 49) means a pollution control device or an assembly of such devices covered by the type-approval granted for the vehicle concerned.

(UN Reg. 103) means a pollution control device or an assembly of such devices covered by the type approval delivered for the vehicle and whose types are indicated in the documents of communication with the approval authority.

PARENT ENGINE (GRPE)

(UN Reg. 49, 96 and 132) means an engine selected from an engine family in such a way that its emissions characteristics will be representative for that engine family.

(UN Reg. 120) means an engine selected from an engine family in such a way that it complies with the essential characteristics of the engine family.

PARENT VEHICLE (GRPE)

(UN Reg. 83) means a vehicle that is selected to act as the vehicle on which the self-adaptability of a fuelling system is going to be demonstrated, and to which the members of a family refer. It is possible to have more than one parent vehicle in a family.

(UN Reg. 115) with regard both to LPG system and to CNG system, means a vehicle that is selected to act as the vehicle, on which the requirements of this Regulation are going to be demonstrated, and to which the members of a family refer.

PARTIAL FLOW DILUTION METHOD (GRPE)

(UN Reg. 96) means the process of separating a part from the total exhaust flow, then mixing it with an appropriate amount of dilution air prior to the particulate sampling filter.

(UN Reg. 49) means the process of separating a part from the total exhaust flow, then mixing it with an appropriate amount of diluent prior to the particulate sampling filter.

PARTICULATE MATTER “PM” (GRPE)

(UN Reg. 49) means any material collected on a specified filter medium after diluting exhaust with a clean filtered diluents to a temperature between 315 K (42 °C) and 325 K (52 °C); this is primarily carbon, condensed hydrocarbons, and sulphates with associated water.

(UN Reg. 96) means any material collected on a specified filter medium after diluting C.I. engine exhaust gas with clean filtered air so that the temperature does not exceed 325 K (52 °C).

(UN Reg. 132) means the mass of any material collected on a specified filter medium.

PARTICULATE POLLUTANTS (GRPE)

(UN Reg. 49) means any material collected on a specified filter medium after diluting the exhaust with clean filtered air so that the temperature does not exceed 325 K (52 °C).

(UN Reg. 83) means components of the exhaust gas which are removed from the diluted exhaust gas at a maximum temperature of 325 K (52 °C) by means of filters.

The particulate sampling unit shall consist of a sampling probe located in the dilution tunnel, a particle transfer tube, a filter holder, a partial-flow pump, and flow rate regulators and measuring units.

It is recommended that a particle size pre-classifier (e.g. cyclone or impactor) be employed upstream of the filter holder. However, a sampling probe, acting as an appropriate size-classification device such as that shown in figure below, is acceptable.

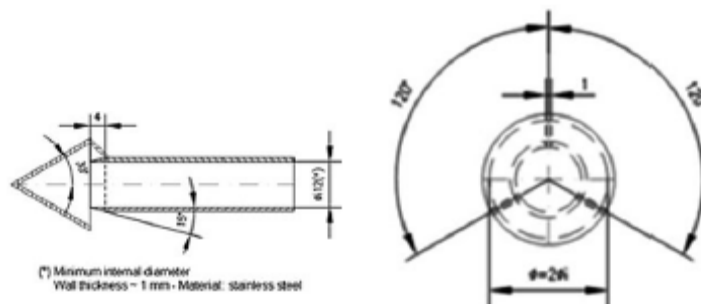

PERIODIC REGENERATION (GRPE)

(UN Reg. 49) means the regeneration process of an emission control device that occurs periodically in less than 100 hours of normal engine operation.

(UN Reg. 132) means the regeneration process of an emission control device that occurs periodically in typically less than 100 hours of normal engine operation. During cycles where regeneration occurs, emission standards can be exceeded.

PERIODICALLY REGENERATING SYSTEM (GRPE)

(UN Reg. 83) means an anti-pollution device (e.g. catalytic converter, particulate trap) that requires a periodical regeneration process in less than 4,000 km of normal vehicle operation.

During cycles where regeneration occurs, emission standards can be exceeded. If a regeneration of an anti-pollution device occurs at least once per Type I test and that has already regenerated at least once during vehicle preparation cycle, it will be considered as a continuously regenerating system which does not require a special test procedure. Emissions test procedure for a vehicle equipped with a periodically regenerating system, does not apply to continuously regenerating systems.

At the request of the manufacturer, the test procedure specific to periodically regenerating systems will not apply to a regenerative device if the manufacturer provides data to the type Approval Authority that, during cycles where regeneration occurs; emissions remain below the standards for the concerned vehicle category after agreement of the Technical Service.

(UN Reg. 101) means an anti-pollution device (e.g. catalytic converter, particulate trap) that requires a periodical regeneration process in less than 4,000 km of normal vehicle operation. If a regeneration of an anti-pollution device occurs at least once per Type I test and that has already regenerated at least once during the vehicle preparation cycle, it will be considered as a continuously regenerating system, which does not require a special test procedure. Emissions test procedure for a vehicle equipped with a periodically regenerating system does not apply to continuously regenerating systems.

At the request of the manufacturer, the test procedure specific to periodically regenerating systems will not apply to a regenerative device if the manufacturer provides data to the type approval authority that, during cycles where regeneration occurs, emission of CO₂ does not exceed the declared value by more than 4 per cent after agreement of the technical service.

(UN Reg. 103) means catalytic converters, particulate filters or other pollution control devices that require a periodical regeneration process in less than 4,000 km of normal vehicle operation.

POWER TRAIN (GRPE)

(UN Reg. 85) For a hybrid electric vehicle, comprises a combination of two different drive train types:

- An internal combustion engine
- One (or several) electric drive train(s).

(UN Reg. 101) means the system of energy storage device(s), energy converter(s) and transmission(s) that converts stored energy to mechanical energy delivered at the wheels for propulsion of the vehicle.

RATED SPEED (GRPE)

(UN Reg. 49) means the maximum full load speed allowed by the governor as specified by the manufacturer in his sales and service literature, or, if such a governor is not present, the speed at which the maximum power is obtained from the engine, as specified by the manufacturer in his sales and service literature.

(UN Reg. 96 and 120) means the maximum full load speed allowed by the governor, as designed by the manufacturer, or, if such a governor is not present, the speed at which the maximum power is obtained from the engine, as designed by the manufacturer.

REAGENT (GRPE)

(UN Reg. 49 and 132) means any medium that is stored on-board the vehicle in a tank and provided to the exhaust aftertreatment system, if required, upon request of the emission control system.

(UN Reg. 96) means any consumable or non-recoverable medium required and used for the effective operation of the exhaust after-treatment system.

REFERENCE MASS (GRPE, GRSP)

(UN Reg. 49) means the mass of the vehicle in running order less the uniform mass of the driver of 75 kg and increased by a uniform mass of 100 kg.

(UN Reg. 83, 84 and 101) means the “unladen mass” of the vehicle increased by a uniform figure of 100 kg.

(UN Reg. 95) means the “unladen mass” of the vehicle increased by a mass of 100 kg that is the mass of the side impact dummy and its instrumentation.

REFERENCE WEIGHT (GRPE)

(UN Reg. 40) means the weight of the vehicle in running order increased by a uniform figure of 75 kg. The weight of the vehicle in running order is its total unladen weight with all tanks full.

(UN Reg. 47) means the weight of the vehicle in running order, increased by a uniform figure of 75 kg. The weight of the vehicle in running order is its total unladen weight with all tanks filled to within 90 per cent of their maximum capacity.

REPLACEMENT POLLUTION CONTROL DEVICE (GRPE)

(UN Reg. 49) means a pollution control device or an assembly of such devices intended to replace an original pollution control device and which can be approved as a separate technical unit.

(UN Reg. 103) means a pollution control device or an assembly of such devices, other than the original pollution control device.

RISE TIME (GRPE)

(UN Reg. 49) means the time between the 10 per cent and 90 per cent response of the final reading ($t_{90} - t_{10}$).

(UN Reg. 96) means the difference in time between the 10 per cent and 90 per cent response of the final reading ($t_{90} - t_{10}$).

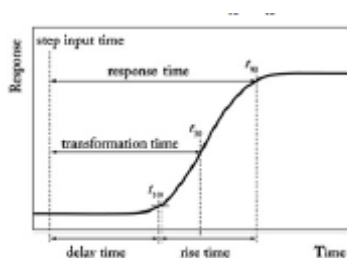

SCAN-TOOL (GRPE)

(UN Reg. 49) means external test equipment used for standardised off-board communication with the OBD system.

(UN Reg. 132) means external test equipment used for off-board communication with the NCD system.

STANDARDIZED (GRPE)

(UN Reg. 49) means that all emission related OBD data (i.e. stream information in the case a scanning tool is used), including all fault codes used, shall be produced only in accordance with industry standards which, by virtue of the fact that their format and the permitted options are clearly defined, provide for a maximum level of harmonisation in the motor vehicle industry.

(UN Reg. 103) means that all data stream information, including all fault codes used, shall be produced only in accordance with industry standards which, by virtue of the fact that their format and their permitted options are clearly defined, provide for a maximum level of harmonisation in the motor vehicle industry.

TRANSFORMATION TIME (GRPE)

(UN Reg. 49) means the difference in time between the change of the component to be measured at the reference point and a system response of 50 per cent of the final reading (t_{50}) with the sampling probe being defined as the reference point. The transformation time is used for the signal alignment of different measurement instruments.

(UN Reg. 96) means the difference in time between the change of the component to be measured at the reference point and a system response of 50 per cent of the final reading (t_{50}) with the sampling probe being defined as the reference point. The transformation time is used for the signal alignment of different measurement instruments.

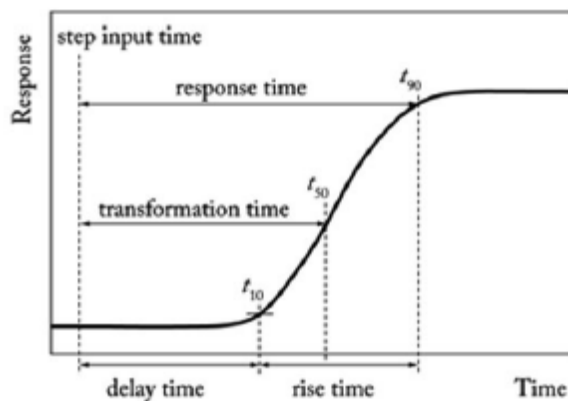

UNLADEN MASS “MV” (GRSG, GRPE, GRRF, GRSP)

(UN Reg. 34 and 73) means the mass of the vehicle in running order, unoccupied and unladen but complete with fuel, coolant, lubricants, tools and a spare wheel, if it is provided as standard equipment by the vehicle manufacturer.

(UN Reg. 36 and 52) means the unladen kerb mass (MK) (kg) of the vehicle, with the addition of 75 kg for the mass of the crew member corresponding to the seat, if any, specially assigned to this crew member. The vehicle shall be complete with 90 per cent of the capacity of all additional liquid tanks. Where facilities such as a kitchen or toilet are fitted, the fresh water tanks shall be full and the waste tanks empty.

(UN Reg. 49 and 83) means the mass of the vehicle in running order without the uniform mass of the driver of 75 kg, passenger or load, but with the fuel tank 90 per cent full and the usual set of tools and spare wheel on board, where applicable.

(UN Reg. 58) means the mass of the vehicle in running order, unoccupied and unladen but complete with fuel, coolant, lubricant, tools and a spare wheel, if provided as standard equipment by the vehicle manufacturer.

(UN Reg. 68) means the mass of the vehicle in running order without occupants or load, but with the fuel tank full (if any), cooling liquid, service and traction batteries, oils, onboard charger, portable charger, tools and spare wheel, if provided in series by the manufacturer of the vehicle.

(UN Reg. 84 and 89) means the mass of the vehicle in running order without crew, passengers or load, but with the fuel tank full and the usual set of tools and spare wheel on board, where applicable.

(UN Reg. 95) means the mass of the vehicle in running order without driver, passengers or load, but with the fuel tank filled to 90 per cent of its capacity and the usual set of tools and spare wheel on board, where applicable.

(UN Reg. 101) means the mass of the vehicle in running order without crew, passengers or load, but with the fuel tank full (if any), cooling liquid, service and traction batteries, oils, onboard charger, portable charger, tools and spare wheel, whatever is appropriate for the vehicle considered and if provided by the manufacturer of the vehicle.

USEFUL LIFE (GRPE)

(UN Reg. 49) means the relevant period of distance and/or time over which compliance with the relevant gaseous and particulate emission limits has to be assured.

(UN Reg. 96) means the relevant period of distance and/or time over which compliance with the relevant gaseous and particulate emission limits has to be assured.

VEHICLE (GRSG, GRPE)

(UN Reg. 36) means a single deck vehicle designed and equipped for the transport of more than 22 passengers. There are three Classes of vehicles. A vehicle may be regarded as belonging in more than one class. In such a case it may be approved for each class to which it corresponds.

- Class I: Vehicles constructed with areas for standing passengers, to allow frequent passenger movement.
- Class II: Vehicles constructed principally for the carriage of seated passengers, and designed to allow the carriage of standing passengers in the gangway and/or in a standing area which does not exceed the space provided for two double seats.
- Class III: Vehicles constructed exclusively for the carriage of seated passengers.
- Trolleybus: A vehicle of Classes I, II, or III, electrically driven by energy from external wires.
- Articulated vehicle: A vehicle which consists of two or more rigid sections which articulate relative to one another; the passenger compartments of each section intercommunicate so that passengers can move freely between them; the rigid sections are permanently connected so that they can only be separated by an operation involving facilities which are normally only found in a workshop.
- Low floor vehicle: A vehicle in which at least 35 per cent of the area available for standing passengers, or of its forward section in the case of articulated vehicles, forms a single area without steps, reached through at least one service door by a single step from the ground.

(UN Reg. 52) means a single-deck vehicle of category M₂ or M₃ designed and constructed for the carriage of seated, or seated and standing persons and having a capacity not exceeding 22 passengers in addition to the driver.

There are two classes of vehicles:

- Class A: Vehicles designed to carry standing passengers; a vehicle of this class has seats and may have provision for standing passengers.
- Class B: Vehicles not designed to carry standing passengers; a vehicle of this class has no provisions for standing passengers.

(UN Reg. 60) means a two-wheeled motor cycle or a two-wheeled moped.

(UN Reg. 66) means a bus or coach designed and equipped for transportation of passengers. The vehicle is an individual representative of a vehicle type.

(UN Reg. 107) means a vehicle of category M₂ or M₃ within the scope defined every single-deck, double-deck, rigid or articulated vehicle of category M₂ or M₃.

(UN Reg. 122) means a vehicle of category M, N or O in which a heating system is fitted.

(UN, RE3) means a moped or a motor-cycle as defined in the Vienna Convention on Road Traffic, 1968, article 1 (m) and (n) respectively, to the exclusion of vehicles equipped with side-cars or having three wheels.

(UN Reg. 43) means any motor vehicle and its trailer, intended for use on the road, having at least four wheels and a maximum design speed exceeding 25 km/h, with the exception of vehicles which run on rails and all mobile machinery.

(UN Reg. 133) means any power-driven vehicle which is normally used for carrying persons or goods by road or for drawing, on the road, vehicles used for the carriage of persons or goods. This term embraces trolley-buses, that is to say, vehicles connected to an electric conductor and not rail-borne. It does not cover vehicles such as agricultural tractors, which are only incidentally used for carrying persons or goods by road or for drawing, on the road, vehicles used for the carriage of persons or goods.

WARM-UP CYCLE (GRPE)

(UN Reg. 49) means sufficient engine operation such that the coolant temperature has risen by at least 22 K (22 °C / 40 °F) from engine starting and reaches a minimum temperature of 333 K (60 °C / 140 °F)

This definition does not imply that a temperature sensor is necessary to measure the coolant temperature.

(UN Reg. 103) means sufficient vehicle operation such that the coolant temperature has risen by a least 22 K from engine starting and reaches a minimum temperature of 343 K (70 °C).