

Definitions in Lighting and Light-Signalling Regulations

Contents

ANGLES OF GEOMETRIC VISIBILITY (GRE).....	3
ANGULAR DIAMETER OF THE RETRO-REFLECTING DEVICE (GRE).....	3
ANGULAR DIAMETER OF THE RETRO-REFLECTIVE SAMPLE “symbol η_1 ” (GRE)	3
APPARENT SURFACE FOR A DEFINED DIRECTION OF OBSERVATION (GRE).....	3
AXIS OF REFERENCE (GRE).....	5
BALLAST (GRE).....	5
CLOSED-CIRCUIT TELL-TALE (GRE).....	5
COEFFICIENT OF LUMINOUS INTENSITY “CIL” (GRE)	5
COEFFICIENT OF RETRO-REFLECTION “R” (GRE).....	5
COMBINED LAMPS (GRE)	5
COUPLING SYSTEM FOR CHARGING THE RECHARGEABLE ENERGY STORAGE SYSTEM “RESS” or “REESS” (GRE, GRSP).....	6
DEVICE (GRE, GRSG).....	6
DIRECTION-INDICATOR LAMP (GRE).....	6
DISTANCE BETWEEN TWO LAMPS WHICH FACE IN THE SAME DIRECTION (GRE).....	6
END-OUTLINE MARKER LAMP (GRE).....	6
ENTRANCE ANGLE (symbol β) (GRE).....	6
EQUIVALENT LAMPS (GRE).....	7
EXTREME OUTER EDGE (GRSG, GRE)	7
FRONT POSITION LAMP (GRE).....	8
GROUPED LAMPS (GRE).....	8
HAZARD WARNING SIGNAL (GRE)	8
HEADLAMPS OF DIFFERENT TYPES (GRE).....	8
ILLUMINATING SURFACE OF A LIGHT-SIGNALLING DEVICE OTHER THAN A RETRO- REFLECTOR (GRE).....	10
ILLUMINATING SURFACE OF A LIGHTING DEVICE (GRE).....	10
ILLUMINATING SURFACE OF A RETRO-REFLECTOR (GRE)	11
INDEPENDENT LAMPS (GRE).....	11
LADEN VEHICLE (GRRF, GRE, GRSG)	11
LAMP (GRE).....	11
LENS (GRE).....	11

LIGHTING UNIT (GRE)	11
MASS IN RUNNING ORDER (GRE, GRSP)	11
MAXIMUM MASS (GRRF, GRE, GRSG, GRPE)	12
OPERATING TELL-TALE (GRE)	13
OPTIONAL LAMP (GRE)	13
OVER-ALL WIDTH/OVERALL WIDTH (GRE, GRRF, GRB)	13
PARKING LAMP (GRE)	13
PASSING BEAM “DIPPED-BEAM” HEADLAMP (GRE)	13
REAR POSITION LAMP (GRE)	14
REAR REGISTRATION PLATE LAMP (GRE)	14
RECIPROCALLY INCORPORATED LAMPS (GRE)	14
REFERENCE AXIS (symbol R) (GRE)	14
REFERENCE CENTRE (GRE)	15
RETRO-REFLECTION (GRE)	15
RETRO-REFLECTOR (GRE)	15
REVERSING LAMP (GRE)	16
SAMPLE UNIT (GRE)	16
SECOND COMPONENT OF THE ENTRANCE ANGLE (symbol β_2) (GRE)	16
SINGLE LAMP (GRE)	16
STOP LAMP (GRE)	17
TRANSVERSE PLANE (GRSP, GRSG, GRE)	17
UNLADEN VEHICLE (GRSG, GRE)	17

ANGLES OF GEOMETRIC VISIBILITY (GRE)

(UN Reg. Nos. 48, 65, 77, 87, 91, 98, 104, 112 and 123) means the angles which determine the field of the minimum solid angle in which the apparent surface of the lamp is visible. That field of the solid angle is determined by the segments of the sphere of which the centre coincides with the centre of reference of the lamp and the equator is parallel with the ground. These segments are determined in relation to the axis of reference. The horizontal angles β correspond to the longitude and the vertical angles α to the latitude.

(UN Reg. Nos. 50, 53, 74 and 113) means the angles which determine the field of the minimum solid angle in which the apparent surface of the lamp must be visible. That field of the solid angle is determined by the segments of the sphere of which the centre coincides with the centre of reference of the lamp and the equator is parallel with the ground. These segments are determined in relation to the axis of reference. The horizontal angles β , correspond to the longitude and the vertical angles α to the latitude. There must be no obstacle on the inside of the angles of geometric visibility to the propagation of light from any part of the apparent surface of the lamp observed from infinity. If measurements are taken closer to the lamp, the direction of observation must be shifted parallel to achieve the same accuracy.

On the inside of the angles of geometric visibility no account is taken of obstacles, if they were already presented when the lamp was type-approved.

If, when the lamp is installed, any part of the apparent surface of the lamp is hidden by any further parts of the vehicle, proof shall be furnished that the part of the lamp not hidden by obstacles still conforms to the photometric values prescribed for the approval of the device as an optical unit. Nevertheless, when the vertical angle of geometric visibility below the horizontal may be reduced to 5° (lamp at less than 750 mm above the ground) the photometric field of measurements of the installed optical unit may be reduced to 5° below the horizontal.

(UN Reg. Nos. 86) means the angles which determine the field of the minimum solid angle in which the apparent surface of the lamp must be visible. That field of the solid angle is determined by the segments of the sphere of which the centre coincides with the centre of reference of the lamp and the equator is parallel with the ground. These segments are determined in relation to the axis of reference. The horizontal angles β correspond to the longitude and the vertical angles α to the latitude. There must be no obstacle on the inside of the angles of geometric visibility to the propagation of light from any part of the apparent surface of the lamp observed from infinity. If measurements are taken closer to the lamp, the direction of observation must be shifted parallel to achieve the same accuracy.

On the inside of the angles of geometric visibility no account is taken of obstacles, if they were already presented when the lamp was type-approved.

If, when the lamp is installed, any part of the apparent surface of the lamp is hidden by any further parts of the vehicle, proof shall be furnished that the part of the lamp not hidden by obstacles still conforms to the photometric values prescribed for the approval of the device as an optical unit.

ANGULAR DIAMETER OF THE RETRO-REFLECTING DEVICE (GRE)

(UN Reg. Nos. 3) means the angle subtended by the greatest dimension of the visible area of the illuminating surface, either at the centre of the source of illumination or at the centre of the receiver.

(UN Reg. Nos. 88) means the angle subtended by the greatest dimension of the visible area of the retroreflective annulus, either at the centre of the source of illumination or at the centre of the receiver.

ANGULAR DIAMETER OF THE RETRO-REFLECTIVE SAMPLE “symbol η_1 ” (GRE)

(UN Reg. Nos. 69 and 70) the angle subtended by the greatest dimension of the retro-reflective sample, either at the centre of the source of illumination or at the centre of the receiver.

(UN Reg. Nos. 104) means the angle subtended by the greatest dimension of the retro-reflective sample, either at the centre of the source of illumination or at the centre of the receiver ($\beta_1 = \beta_2 = 0^\circ$).

APPARENT SURFACE FOR A DEFINED DIRECTION OF OBSERVATION (GRE)

(UN Reg. Nos. 48, 65, 77, 87, 91, 98, 112 and 123) means, at the request of the manufacturer or his duly accredited representative, the orthogonal projection of:

- Either the boundary of the illuminating surface projected on the exterior surface of the lens, or the light-emitting surface.
- Only in the case of a light-signalling device producing variable luminous intensities, its apparent surface that may be variable, shall be considered under all conditions permitted by the variable intensity control, if applicable.
- In a plane perpendicular to the direction of observation and tangential to the most exterior point of the lens.

(UN Reg. Nos. 50, 53, 74 and 113) means, at the request of the manufacturer or his duly accredited representative, the orthogonal projection of either the boundary of the illuminating surface projected on the exterior surface of the lens (a-b), or the light-emitting surface (c-d), in a plane perpendicular to the direction of observation and tangential to the most exterior point of the lens. As shown in the figure below.

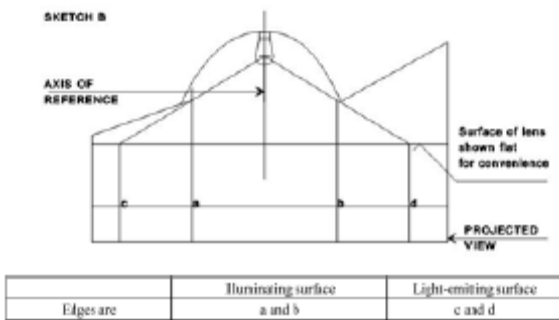
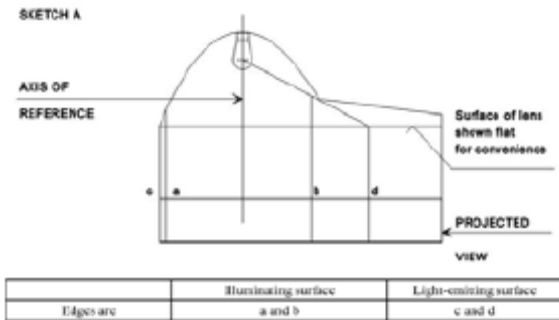

(UN Reg. Nos. 86) for a defined direction of observation, means the orthogonal projection of the light-emitting surface in a plane perpendicular to the direction of observation, see figure below.

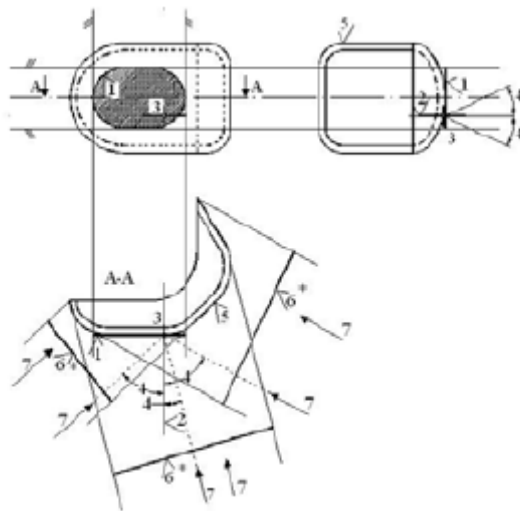

This surface is to be considered as tangent to the light-emitting surface.

- 1 illuminating surface
- 2 axis of reference
- 3 centre of reference
- 4 angles of geometric visibility
- 5 light-emitting surfaces
- 6 apparent surfaces
- 7 direction of observation

AXIS OF REFERENCE (GRE)

(UN Reg. Nos. 48, 50, 53, 65, 74, 77, 87, 91, 98, 112, 113 and 123) means the characteristic axis of the lamp determined by the manufacturer of the lamp, for use as the direction of reference ($H = 0^\circ$, $V = 0^\circ$) for angles of field for photometric measurements and for installing the lamp on the vehicle.

(UN Reg. Nos. 86) means the characteristic axis of the light signal determined by the manufacturer of the lamp, for use as the direction of reference ($H = 0^\circ$, $V = 0^\circ$) for photometric measurements and when fitting the lamp on the tractor.

BALLAST (GRE)

(UN Reg. Nos. 48, 65, 77, 87, 91, 98, 112 and 123) means an electronic light source control gear between supply and light source, whether or not integrated with the light source or applied lamp, to stabilise the electrical current of a gas-discharge light source.

(UN Reg. Nos. 98 and 113) means the electrical supply of the gas-discharge light source. This ballast may be partly or completely inside or outside the headlamp.

CLOSED-CIRCUIT TELL-TALE (GRE)

(UN Reg. Nos. 48, 50, 53, 74 and 113) means a visual, or any equivalent signal, indicating that a device has been switched on, but not indicating whether it is operating correctly or not.

(UN Reg. Nos. 86) means a tell-tale showing that a device has been switched on but not showing whether it is operating correctly or not.

COEFFICIENT OF LUMINOUS INTENSITY "CIL" (GRE)

(UN Reg. Nos. 3) means the quotient of the luminous intensity reflected in the direction considered, divided by the illumination of the retro-reflecting device for given angles of illumination, divergence and rotation.

(UN Reg. Nos. 27) means the amount of luminous intensity reflected in the direction considered, divided by the illumination of the retro-reflecting device for given angles of illumination, divergence and rotation. The illumination is measured in a plane normal to the direction of the incident light.

(UN Reg. Nos. 88) is the quotient from dividing the luminous intensity "I" of the retroreflector in the direction of observation by the illuminance "" at the retroreflector on a plane perpendicular to the direction of the incident light. Symbol R.

$R=I/$

In the photometry of retroreflectors this coefficient is expressed in millicandelas per lux "mcd.lx-1".

COEFFICIENT OF RETRO-REFLECTION "R" (GRE)

(UN Reg. Nos. 69 and 70) Coefficient (R') obtained from the luminous intensity (I) of the retro-reflective area in the direction of observation and the illuminance (E) on the retro-reflective plane at right angles to the direction of the incident light and the illuminated plane sample surface A.

Where:

R' Coefficient of retro-reflection

I luminous intensity

E illuminance on the retro reflective plane at right angles

A illuminated surface

The coefficient of retro-reflection R' is expressed in candela per square meter per lux (cd. m⁻². lx⁻¹).

(UN Reg. Nos. 104) means the quotient of the coefficient of luminous intensity R of a plane retro-reflecting surface and its area A.

$R'=R/A$ $R'=I/(E \times A)$

The coefficient of retro-reflexion R' is expressed in candelas per m² per lx (cd.m².lx⁻¹)

(Luminance / Illumination)

COMBINED LAMPS (GRE)

(UN Reg. Nos. 48, 65, 77, 87, 91, 98, 112 and 123) means devices having separate apparent surfaces in the direction of the reference axis, but a common light source and a common lamp body. In the case of lighting devices for the rear registration plate and direction-indicators of categories 5 and 6, the "light-emitting surface" shall be used.

(UN Reg. Nos. 50, 53, 74 and 113) means devices having separate illuminating surfaces, but a common light source and a common lamp body.

(UN Reg. Nos. 86) means devices having separate lenses but a common light source and a common lamp body.

COUPLING SYSTEM FOR CHARGING THE RECHARGEABLE ENERGY STORAGE SYSTEM “RESS” or “REESS” (GRE, GRSP)

(UN Reg. Nos. 10) means the electrical circuit installed in the vehicle used for charging the RESS.

(UN Reg. Nos. 12, 94, 95 and 100) means the electrical circuit used for charging the RESS from an external electrical power supply including the vehicle inlet.

DEVICE (GRE, GRSG)

(UN Reg. Nos. 48, 65, 77, 87, 91, 98, 104, 112, 121 and 123) means an element or an assembly of elements used to perform one or more functions.

(UN Reg. Nos. 50, 53, 74 and 113) means a component or combination of components used in order to perform one or several functions.

DIRECTION-INDICATOR LAMP (GRE)

(UN Reg. Nos. 6 and 48) means the lamp used to indicate to other road-users that the driver intends to change direction to the right or to the left.

(UN Reg. Nos. 50, 53, 74 and 113) means the lamp used to indicate to other road-users that the driver intends to change direction to the right or to the left.

A direction-indicator lamp or lamps may also be used according to provisions of the vehicle alarm system regulation.

(UN Reg. Nos. 86) means the lamp used to indicate to other road-users that the driver intends to change direction to the right or to the left.

DISTANCE BETWEEN TWO LAMPS WHICH FACE IN THE SAME DIRECTION (GRE)

(UN Reg. Nos. 48, 65, 77, 87, 91, 98, 112 and 123) means the shortest distance between the two apparent surfaces in the direction of the reference axis. Where the distance between the lamps clearly meets the requirements of the Regulation, the exact edges of apparent surfaces need not be determined.

(UN Reg. Nos. 86) means the distance between the orthogonal projections in a plane perpendicular to the direction in question of the outlines of the two illuminating surfaces as defined according to the case mentioned in the illuminating surface of a lamp.

END-OUTLINE MARKER LAMP (GRE)

(UN Reg. Nos. 7) means a lamp fitted near to the extreme outer edges and as close as possible to the top of the vehicle and intended to indicate clearly the vehicle's overall width. In the case of certain power-driven vehicles and trailers, this lamp is intended to complement the vehicle's position lamps and draw special attention to its outline.

(UN Reg. Nos. 48) means the lamp fitted near to the extreme outer edge and as close as possible to the top of the vehicle and intended to indicate clearly the vehicle's overall width. This lamp is intended, for certain vehicles and trailers, to complement the vehicle's front and rear position lamps by drawing particular attention to its bulk.

(UN Reg. Nos. 86) means the lamp fitted to the extreme outer edge as close as possible to the top of the tractor and intended clearly to indicate the tractor's overall width. This signal is intended, for certain tractors, to complement the tractor's front and rear position (side) lamps by drawing particular attention to its bulk.

ENTRANCE ANGLE (symbol β) (GRE)

(UN Reg. Nos. 69, 70 and 88) is the angle from the illumination axis to the reference axis. The entrance angle is usually not larger than 90° but, for completeness, its full range is defined as $0^\circ \leq \beta \leq 180^\circ$. In order to specify the orientation in full, this angle is characterized by two components, β_1 and β_2 .

(UN Reg. Nos. 104) means the angle from the illumination axis to the reference axis. The entrance angle is usually not larger than 90° but, for completeness, its full range is defined as $0^\circ < \beta < 180^\circ$. In order to specify the orientation in full, this angle is characterised by two components, β_1 and β_2 .

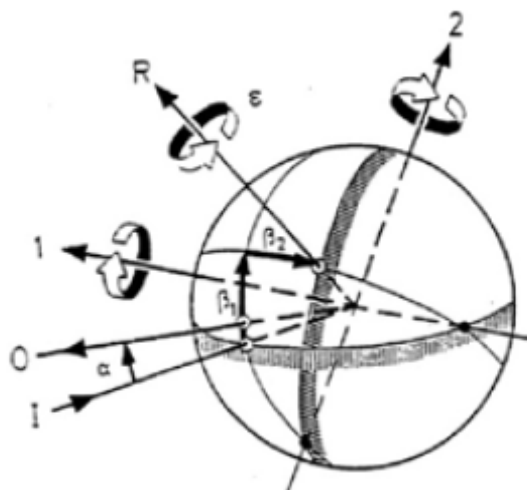

The CIE co-ordinate system

1: First Axis

2: Second Axis

I: Illumination Axis

O: Observation Axis

R: Reference Axis

α : Observation angle

β_1, β_2 : Entrance angles

ϵ : Rotation angle

The CIE angular system for specifying and measuring retro-reflective marking materials. The first axis is perpendicular to the plane containing the observation axis and the illumination axis. The second axis is perpendicular both to the first axis and to the reference axis. All axes, angles, and directions of rotation are shown positive.

Notes:

- The principle fixed axis is the illumination axis.
- The first axis is fixed perpendicular to the plane containing the observation and illumination axis.
- The reference axis is fixed in the retro-reflective material and moveable with β_1 and β_2 .

EQUIVALENT LAMPS (GRE)

(*UN Reg. Nos. 48, 65, 77, 87, 91, 98, 112 and 123*) means lamps having the same function and authorized in the country in which the vehicle is registered; such lamps may have different characteristics from those installed on the vehicle when it is approved on condition that they satisfy their requirements.

(*UN Reg. Nos. 50, 53, 74 and 113*) means lamps having the same function and authorized in the country in which the vehicle is registered; such lamps may have different characteristics from those of the lamps with which the vehicle is equipped at the time of approval, on condition that they satisfy the requirements of the Regulation for installation of lighting and light-signalling devices for motorcycles.

(*UN Reg. Nos. 86*) means lamps having the same function and approved under filament lamps for use in approved lamp unit's Regulation or in conformity with the same requirements; such lamps may have different characteristics from those of the lamps with which the vehicle is equipped at the time of approval on condition that they satisfy the requirements of the installation of light-signalling devices for agricultural tractor's Regulation.

EXTREME OUTER EDGE (GRSG, GRE)

(*UN Reg. Nos. 26*) of the vehicle, means, in relation to the sides of the vehicle, the plane parallel to the median longitudinal plane of the vehicle coinciding with its outer lateral edge, and, in relation to the front and rear ends, the perpendicular transverse plane of the vehicle coinciding with its outer front and rear edges, account not being taken of the projection:

- Of tyres near their point of contact with the ground, and connections for tyre pressure gauges; of any anti-skid devices which may be mounted on the wheels.
- Of rear-view mirrors.
- Of side direction indicator lamps, end outline marker lamps, front and rear position (side) lamps and parking lamps.
- In relation to the front and rear ends, of parts mounted on the bumpers, of towing devices and of exhaust pipes.

(*UN Reg. Nos. 50, 53 and 113*) on either side of the vehicle means the plane parallel to the median longitudinal plane of the vehicle and touching the lateral extremity of the vehicle, disregarding the projection or projections:

- Of rear-view mirrors.
- Of direction-indicator lamps.
- Of front and rear position lamps and retro-reflectors.

(*UN Reg. Nos. 74 and 113*) on either side of the vehicle means the plane parallel to the median longitudinal plane of the vehicle and tangent to the latter's lateral outer edge, disregarding rear-view mirrors, direction indicators, position lamps and retro-reflectors.

(*UN Reg. Nos. 86*) on either side of the tractor means the plane parallel with the median longitudinal plane of the tractor and coinciding with its lateral outer edge, disregarding the projection:

- Of tyres near their point of contact with the ground and connections for tyre-pressure gauges.
- Of any anti-skid devices which may be mounted on the wheels.
- Of rear-view mirrors.
- Of side direction indicator lamps, end-outline marker lamps, front and rear position (side) lamps, parking lamps and lateral reflex reflectors.
- Of customs seals affixed to the tractor and devices for securing and protecting such seals.

FRONT POSITION LAMP (GRE)

(*UN Reg. Nos. 7 and 48*) means the lamp used to indicate the presence and the width of the vehicle when viewed from the front.

(*UN Reg. Nos. 50, 53, 74 and 113*) means the lamp used to indicate the presence of the vehicle when viewed from the front.

GROUPED LAMPS (GRE)

(*UN Reg. Nos. 48, 65, 77, 87, 91, 98, 112 and 123*) means devices having separate apparent surfaces in the direction of the reference axis and separate light sources, but a common lamp body. In the case of lighting devices for the rear registration plate and direction-indicators of categories 5 and 6, the "light-emitting surface" shall be used.

(*UN Reg. Nos. 50, 53, 74 and 113*) means devices having separate illuminating surfaces and separate light sources, but a common lamp body.

(*UN Reg. Nos. 86*) means devices having separate lenses and separate light sources, but a common lamp body.

HAZARD WARNING SIGNAL (GRE)

(*UN Reg. Nos. 48, 50, 53, 65 and 113*) means the simultaneous operation of all of a vehicle's direction-indicator lamps to show that the vehicle temporarily constitutes a special danger to other road-users.

(*UN Reg. Nos. 86*) means the device permitting the simultaneous operation of all of a tractor's direction indicator lamps to draw attention to the fact that the tractor temporarily constitutes a special danger to other road-users.

HEADLAMPS OF DIFFERENT TYPES (GRE)

(*UN Reg. Nos. 1 and 2*) Headlamps which differ in such essential respects as:

- The trade name or mark.
- The characteristics of the optical system.
- The inclusion of additional components capable of altering the optical effects by reflection, refraction or absorption; and/or deformation during operation.
- Suitability for right-hand or left-hand traffic or for both traffic systems.
- Ability to provide a passing beam or a driving beam or both.
- The materials constituting the lenses and coating, if any.

The holder intended to accommodate the filament lamp (or lamps) of one of the following categories: R2 and/or HS1; should not be confused between "type of filament lamp" and "category of filament lamp". Regulation No.1 concerns headlamps using filament lamps of categories R2 and/or HS1. These categories of filament lamps differ essentially in their design and, more particularly, in the cap. They are not interchangeable, but within one filament lamp category there are normally several types.

(*UN Reg. Nos. 8*) are headlamps which differ in such essential respects as:

- The trade name or mark.
- The characteristics of the optical system.
- The inclusion or elimination of components capable of altering the optical effects by reflection, refraction, absorption and/or deformation during operation. However, the fitting or elimination of filters designed solely to change the colour of the beam and not its light distribution shall not constitute a change in the type.

- Suitability for right-hand or left-hand traffic or for both traffic systems.
- The kind of beam produced, passing beam, driving beam or both.
- The holder intended to accommodate the filament lamp (or lamps) of one of the categories H1, H2, H3, HB3, HB4, H7, H8, H9, HIR1, HIR2 and/or H11. These categories of filament lamps differ essentially in their design and, more particularly, in the cap. They are not interchangeable, but within one filament lamp category there may normally be several types. HIR1 and/or H9 filament lamps shall only be permitted to produce passing beam in conjunction with the installation of headlamp cleaning device(s). This restriction shall apply as long as there is no general agreement on the use of levelling devices and headlamp cleaners with respect to the level of the performance of the headlamp.
- The materials constituting the lenses and coating, if any.

(UN Reg. Nos. 56) means headlamps which differ in such essential respects as:

- The trade name or mark.
- The characteristics of the optical system.

The inclusion or the suppression of components capable of altering the optical effects by reflexion, refraction or absorption. A change of colour of the beams emitted by headlamps whose other characteristics are not changed does not constitute a change of headlamp type. The same approval number shall accordingly be assigned to such headlamps.

(UN Reg. Nos. 57) are headlamps which differ in such essential respects as:

- The trade name or mark.
- Marking of the headlamp as defined in the table below.
- The characteristics of the optical system;
- The inclusion or the suppression of components capable of altering the optical effects by reflection, refraction or absorption and/or deformation during operation. A change in the colour of the beams emitted by headlamps whose other characteristics are not changed does not constitute a change of headlamp type. The same approval number shall accordingly be assigned to such headlamps.
- The materials constituting the lenses and coating, if any.

(UN Reg. Nos. 72) means headlamps which differ in such essential respects as:

- The trade name or mark.
- The characteristics of the optical systems.
- The inclusion or elimination of components capable of altering the optical effects by reflection, refraction or absorption and/or deformation during operation. A change in the colour of the beams emitted by headlamps whose other characteristics are not changed does not constitute a change of headlamp type. The same approval number shall accordingly be assigned to such headlamps.

- Suitability for right-hand or left-hand traffic or for both traffic systems.

(UN Reg. Nos. 76) means headlamps which differ in such essential respects as:

- The trade name or mark.
- The characteristics of the optical system.
- The inclusion or the suppression of components capable of altering the optical effects by reflection, refraction or absorption.
- A change in the colour of the beam emitted by a headlamp whose other characteristics are not changed does not constitute a change of headlamp type.

(UN Reg. Nos. 82) means headlamps which differ in such essential respects as:

- The trade name or mark.
- The characteristics of the optical systems.
- The inclusion or elimination of components capable of altering the optical effects by reflection, refraction or absorption. A change in the colour of the beams emitted by headlamps whose other characteristics are not changed does not constitute a change of headlamp type. The same approval number shall accordingly be assigned to such headlamps.

(UN Reg. Nos. 98) are headlamps which differ in such essential respects as:

- The trade name or mark.
- The characteristics of the optical system.
- The inclusion or elimination of components capable of altering the optical effects by reflection, refraction, absorption and/or deformation during operation.
- Suitability for right-hand or left-hand or for both traffic systems.
- The kind of beam produced (passing beam or driving beam or both).
- The materials constituting the lenses and coating, if any.
- However, a device intended for the installation on the left side of the vehicle and the corresponding device intended for the installation on the right side of the vehicle shall be considered to be of the same type.

(UN Reg. Nos. 112) mean headlamps which differ in such essential respects as:

- The trade name or mark.
- The characteristics of the optical system.
- The inclusion or elimination of components capable of altering the optical effects by reflection, refraction, absorption and/or deformation during operation.
- Suitability for right-hand or left-hand traffic or for both traffic systems.
- The kind of beam produced (passing beam, driving beam or both).
- The materials constituting the lenses and coating, if any.
- The category of filament lamp used and/or the LED module specific identification code(s).

However, a device intended for the installation on the left side of the vehicle and the corresponding device intended for the installation on the right side of the vehicle shall be considered to be of the same type.

(UN Reg. Nos. 113) mean headlamps which differ in such essential respects as:

- The trade name or mark.
- The characteristics of the optical system.
- The inclusion or elimination of components capable of altering the optical effects by reflection, refraction, absorption and/or deformation during operation.
- The kind of beam produced (passing beam, driving beam or both).
- The materials constituting the lenses and coating, if any.
 - The category of filament lamp(s), the gas-discharge light source or the light source module specific identification code(s).

ILLUMINATING SURFACE OF A LIGHT-SIGNALLING DEVICE OTHER THAN A RETRO-REFLECTOR (GRE)

(UN Reg. Nos. 48, 77, 87, 91, 98, 112 and 123) means the orthogonal projection of the lamp in a plane perpendicular to its axis of reference and in contact with the exterior light-emitting surface of the lamp, this projection being bounded by the edges of screens situated in this plane, each allowing only 98 per cent of the total luminous intensity of the light to persist in the direction of the axis of reference.

To determine the lower, upper and lateral limits of the illuminating surface only screens with horizontal or vertical edges shall be used to verify the distance to the extreme edges of the vehicle and the height above the ground.

For other applications of the illuminating surface, e.g. distance between two lamps or functions, the shape of the periphery of this illuminating surface shall be used. The screens shall remain parallel, but other orientations are allowed to be used.

In the case of a light-signalling device whose illuminating surface encloses either totally or partially the illuminating surface of another function or encloses a non-lighted surface, the illuminating surface may be considered to be the light emitting surface itself.

(UN Reg. Nos. 6, 7, 38, 50, 53, 65, 74, 86 and 113) For direction-indicator lamp, stop lamp, front position lamp, rear position lamp, hazard warning signal and rear fog lamp is the orthogonal projection of the lamp in a plane perpendicular to its axis of reference and in contact with the exterior light-emitting surface of the lamp, this projection being bounded by the edges of screens situated in this plane, each allowing only 98 per cent of the total luminous intensity of the light to persist in the direction of the axis of reference. To determine the lower, upper and lateral limits of the illuminating surface, only screens with horizontal or vertical edges shall be used.

ILLUMINATING SURFACE OF A LIGHTING DEVICE (GRE)

(UN Reg. Nos. 19, 50, 53, 74 and 113) For driving beam headlamp, passing beam headlamp and front fog lamp, is the orthogonal projection of the full aperture of the reflector, or in the case of headlamps with an ellipsoidal reflector of the "projection lens", on a transverse plane. If the lighting device has no reflector, the definition of Illuminating surface of a light-signalling device other than a retro-reflector, shall be applied. If the light emitting surface of the lamp extends over part only of the full aperture of the reflector, then the projection of that part only is taken into account.

In the case of a passing beam headlamp, the illuminating surface is limited by the apparent trace of the cut-off on to the lens. If the reflector and lens are adjustable relative to one another, the mean adjustment should be used.

(UN Reg. Nos. 23 and 86) For driving-lamp, passing lamp, front fog-lamp and reversing lamp, is the orthogonal projection of the full aperture of the reflector in a transverse plane. If the lamp glass (or glasses) extend(s) over part only of the full aperture of the reflector, then the projection of that part only is taken into account. In the case of a passing lamp, the illuminating surface is limited on the side of the cut-off by the apparent projection of the line of the cut-off on to the lens. If the reflector and glass are adjustable, the mean adjustment should be used.

(UN Reg. Nos. 48, 65, 77, 87, 91, 98, 112 and 123) means the orthogonal projection of the full aperture of the reflector, or in the case of headlamps with an ellipsoidal reflector of the "projection lens", on a transverse plane. If the light emitting surface of the lamp extends over part only of the full aperture of the reflector, then the projection of that part only is taken into account.

In the case of a dipped-beam headlamp, the illuminating surface is limited by the apparent trace of the cut-off on to the lens. If the reflector and lens are adjustable relative to one another, the mean adjustment should be used.

In the case of AFS being installed: where a lighting function is produced by two or more simultaneously operated lighting units on a given side of the vehicle, the individual illuminating surfaces, taken together, constitute the illuminating surface to be considered.

ILLUMINATING SURFACE OF A RETRO-REFLECTOR (GRE)

(UN Reg. Nos. 48 and 104) means, the orthogonal projection of a retro-reflector in a plane perpendicular to its axis of reference and delimited by planes contiguous to the declared outermost parts of the retro-reflectors' optical system and parallel to that axis. For the purposes of determining the lower, upper and lateral edges of the device, only horizontal and vertical planes shall be considered.

(UN Reg. Nos. 50, 53, 74 and 113) Is the orthogonal projection of a retro-reflector in a plane perpendicular to its axis of reference and delimited by planes continuous to the outermost parts of the retro-reflector's optical system and parallel to that axis. For the purposes of determining the lower, upper and lateral edges of the device, only horizontal and vertical planes shall be considered.

INDEPENDENT LAMPS (GRE)

(UN Reg. Nos. 48, 65, 77, 87, 91, 98, 112 and 123) means devices having separate apparent surfaces in the direction of the reference axis, separate light sources and separate lamp bodies. In the case of lighting devices for the rear registration plate and direction-indicators of categories 5 and 6, the "light-emitting surface" shall be used.

(UN Reg. Nos. 86) means devices having separate lenses, separate light sources, and separate lamp bodies.

LADEN VEHICLE (GRRF, GRE, GRSG)

(UN Reg. Nos. 13, 13H and 111) means, except where otherwise stated, a vehicle so laden as to attain its "maximum mass".

(UN Reg. Nos. 26) means the vehicle laden to the maximum permitted technical mass. Vehicles equipped with hydropneumatic, hydraulic or pneumatic suspension or a device for automatic levelling according to load shall be tested with the vehicle in the most adverse normal running condition specified by the manufacturer.

(UN Reg. Nos. 48, 65, 77, 87, 91, 98, 104, 112 and 123) means a vehicle loaded to its technically permissible maximum mass, as stated by the manufacturer, who shall also fix the distribution of this mass between the axles.

LAMP (GRE)

(UN Reg. Nos. 48, 65, 77, 87, 91, 98, 112 and 123) means a device designed to illuminate the road or to emit a light signal to other road users. Rear registration plate lamps and retro-reflectors are likewise to be regarded as lamps. Light-emitting rear registration plates and the service-door-lighting system on vehicles of categories M2 and M3 are not considered as lamps.

(UN Reg. Nos. 50, 53, 74 and 113) means a device designed to illuminate the road or to emit a light signal to other road users. Rear registration plate lamp and retro-reflectors are likewise to be regarded as lamps.

(UN Reg. Nos. 86) means a device designed to illuminate the road (headlamp) or to emit a light signal. Rear registration-plate lamps and retro-reflectors shall likewise be regarded as lamps.

LENS (GRE)

(UN Reg. Nos. 1, 2, 5, 8, 31, 20, 112 and 113) means the outermost component of the headlamp (unit) which transmits light through the illuminating surface.

(UN Reg. Nos. 19, 57 and 98) means the outermost component of the front fog lamp (unit), which transmits light through the illuminating surface.

(UN Reg. Nos. 123) means the outermost component of an installation unit, which transmits light through the illuminating surface.

LIGHTING UNIT (GRE)

(UN Reg. Nos. 48, 65, 77, 87, 91, 98 and 112) means a light-emitting component designed to provide or contribute to one or more front lighting function(s) provided by the AFS.

(UN Reg. Nos. 123) means a light emitting part of the system, which may consist of optical, mechanical and electrical components, designed to provide or contribute to the beam of one or more front-lighting function(s) provided by the system.

MASS IN RUNNING ORDER (GRE, GRSP)

(UN Reg. Nos. 78) means the sum of the unladen vehicle mass and driver mass.

(UN Reg. Nos. 127) means the nominal mass of a vehicle as determined by the sum of unladen vehicle mass and driver's mass.

MAXIMUM MASS (GRRF, GRE, GRSG, GRPE)

(UN Reg. Nos. 13, 13H, 58 and 64) means the maximum mass stated by the vehicle manufacturer to be technically permissible. This mass may be higher than the "permissible maximum mass" laid down by the national administration.

(UN Reg. Nos. 50, 53, 78 and 113) see "Gross vehicle mass" definition.

(UN Reg. Nos. 51, 83 and 84) means the technically permissible maximum mass declared by the vehicle manufacturer. This mass may be greater than the maximum mass authorized by the national administration.

(UN Reg. Nos. 73 and 93) means the mass stated by the vehicle manufacturer to be technically permissible. This mass may be higher than the "permissible maximum mass" laid down by the national administration.

(UN Reg. Nos. 101) means the technically permissible maximum mass declared by the manufacturer. This mass may be greater than the maximum mass authorized by the national administration.

(UN Reg. Nos. 111) means the technically permissible maximum mass stated by the vehicle manufacturer. This mass may be higher than the "permissible maximum mass" laid down by the national administration.

OBSERVATION ANGLE (symbol α) (GRE)

(UN Reg. Nos. 69 and 70) it is the angle between the illumination axis and the observation axis. The observation angle is always positive and, in the case of retro-reflection, is restricted to small angles. Maximum range: $0 \leq \alpha \leq 180^\circ$.

(UN Reg. Nos. 88) it is the angle between the illumination axis and the observation axis. The observation angle is always positive and in the context of retroreflection is restricted to small angles. Maximum range: $0 \leq \alpha < 180^\circ$.

(UN Reg. Nos. 104) means the angle between the illumination axis and the observation axis. The observation angle is always positive and, in the case of retro-reflection, is restricted to small angles.

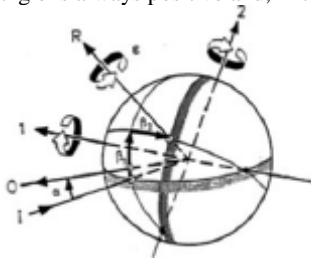

The CIE co-ordinate system

1: First Axis

2: Second Axis

I: Illumination Axis

O: Observation Axis

R: Reference Axis

α : Observation angle

β_1, β_2 : Entrance angles

ϵ : Rotation angle

The CIE angular system for specifying and measuring retro-reflective marking materials. The first axis is perpendicular to the plane containing the observation axis and the illumination axis. The second axis is perpendicular both to the first axis and to the reference axis. All axes, angles, and directions of rotation are shown positive.

Notes:

- The principle fixed axis is the illumination axis.
- The first axis is fixed perpendicular to the plane containing the observation and illumination axis.
- The reference axis is fixed in the retro-reflective material and moveable with β_1 and β_2 .

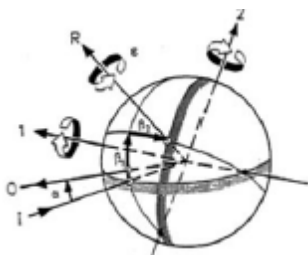

OPERATING TELL-TALE (GRE)

(UN Reg. Nos. 48, 50, 53, 74 and 113) means a visual or auditory signal, or any equivalent signal, indicating that a device has been switched on and is operating correctly or not.

(UN Reg. Nos. 86) means a tell-tale showing whether a device that has been actuated is operating correctly or not.

OPTIONAL LAMP (GRE)

(UN Reg. Nos. 48, 50, 53, 65, 74, 77, 87, 91, 98, 112, 113 and 123) means a lamp, the installation of which is left to the discretion of the manufacturer.

(UN Reg. Nos. 86) means a lamp the presence of which is left to the discretion of the manufacturer.

OVER-ALL WIDTH/OVERALL WIDTH (GRE, GRRF, GRB)

(UN Reg. Nos. 50, 53, 74, 86 and 113) means the distance between the two vertical planes in the “extreme outer edge”.

(UN Reg. Nos. 54 and 117) means the linear distance between the outsides of the sidewalls of an inflated pneumatic tyre, including labelling (marking), decoration and protective bands or ribs.

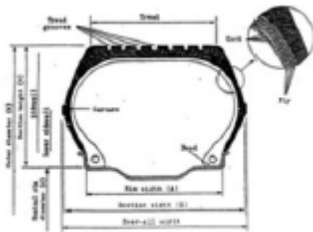

(UN Reg. Nos. 30 and 117) means the linear distance between the outsides of the sidewalls of an inflated pneumatic tyre, including labelling (marking), decoration and protective bands or ribs.

(UN Reg. Nos. 48, 65, 77, 87, 91, 98, 104, 112 and 123) means the distance between the two vertical planes defined in “extreme outer edge on either side of the vehicle”.

(UN Reg. Nos. 75) means the linear distance between the outsides of the side walls of an inflated pneumatic tyre, including labelling (marking), decoration and protective bands or ribs; in the case of tyres where the tread is wider than the section width, the overall width corresponds to the tread width.

(UN Reg. Nos. 106) means the linear distance between the outside of the sidewalls of an inflated tyre, including labelling (marking), decoration and protective bands or ribs.

(UN Reg. Nos. 108 and 109) means the linear distance between the outside of the sidewalls of an inflated pneumatic tyre, when fitted to the specified measuring rim, and including labelling (marking), decoration or protective bands or ribs.

PARKING LAMP (GRE)

(UN Reg. Nos. 48 and 77) means a lamp which is used to draw attention to the presence of a stationary vehicle in a built-up area. In such circumstances it replaces the front and rear position lamps.

(UN Reg. Nos. 86) means the lamp used to draw attention to the presence of a stationary tractor, without a trailer, in a built-up area. In such circumstances it replaces the front and rear position (side) lamps.

PASSING BEAM “DIPPED-BEAM” HEADLAMP (GRE)

(UN Reg. Nos. 48, 98 and 112) means the lamp used to illuminate the road ahead of the vehicle without causing undue dazzle or discomfort to oncoming drivers and other road-users.

(UN Reg. Nos. 50, 53, 74 and 113) means the lamp used to illuminate the road ahead of the vehicle without dazzling or causing undue discomfort to oncoming drivers and other road users.

REAR POSITION LAMP (GRE)

(UN Reg. Nos. 7 and 48) means the lamp used to indicate the presence and width of the vehicle when viewed from the rear.

(UN Reg. Nos. 50, 53, 74 and 113) means the lamp used to indicate the presence of the vehicle when viewed from the rear.

REAR REGISTRATION PLATE LAMP (GRE)

(UN Reg. Nos. 4) means the device for the illumination of rear registration plates, hereinafter called "illuminating device", which illuminates the rear registration plate by reflection. For the approval of this device, the illumination of the space to be occupied by the plate is determined.

(UN Reg. Nos. 86) means the device used to illuminate the space intended to accommodate the rear registration plate; it may consist of several optical components.

RECIPROCALLY INCORPORATED LAMPS (GRE)

(UN Reg. Nos. 48, 65, 77, 87, 91, 98, 112 and 123) means devices having separate light sources or a single light source operating under different conditions (for example, optical, mechanical, electrical differences), totally or partially common apparent surfaces in the direction of the reference axis and a common lamp body. In the case of lighting devices for the rear registration plate and direction-indicators of categories 5 and 6, the "light-emitting surface" shall be used.

(UN Reg. Nos. 86) means devices having separate light sources (or a single light source operating under different conditions), totally or partially common lenses and a common lamp body.

REFERENCE AXIS (symbol R) (GRE)

(UN Reg. Nos. 48, 50, 53, 65, 77, 87, 91, 98, 112, 113 and 123) see "axis of reference" definition.

(UN Reg. Nos. 69, 70 and 104) it is a designated line segment originating on the reference centre which is used to describe the angular position of the retro-reflective device.

(UN Reg. Nos. 88) is the axis of the wheel on which the tyre is mounted.

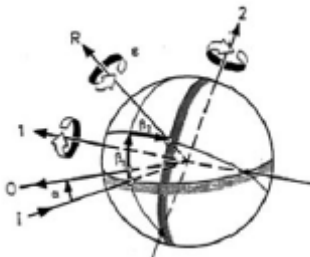

The CIE co-ordinate system

1: First Axis

2: Second Axis

I: Illumination Axis

O: Observation Axis

R: Reference Axis

α : Observation angle

β_1, β_2 : Entrance angles

ϵ : Rotation angle

The CIE angular system for specifying and measuring retro-reflective marking materials. The first axis is perpendicular to the plane containing the observation axis and the illumination axis. The second axis is perpendicular both to the first axis and to the reference axis. All axes, angles, and directions of rotation are shown positive.

Notes:

- The principle fixed axis is the illumination axis.
- The first axis is fixed perpendicular to the plane containing the observation and illumination axis.
- The reference axis is fixed in the retro-reflective material and moveable with β_1 and β_2 .

REFERENCE CENTRE (GRE)

(UN Reg. Nos. 69, 70 and 104) it is a point on or near a retro-reflective area which is designated to be the centre of the device for the purpose of specifying its performance.

(UN Reg. Nos. 88) means a point at the centre of the wheel on which the tyre is mounted.



The CIE co-ordinate system

1: First Axis

2: Second Axis

I: Illumination Axis

O: Observation Axis

R: Reference Axis

α : Observation angle

β_1, β_2 : Entrance angles

ϵ : Rotation angle

The CIE angular system for specifying and measuring retro-reflective marking materials. The first axis is perpendicular to the plane containing the observation axis and the illumination axis. The second axis is perpendicular both to the first axis and to the reference axis. All axes, angles, and directions of rotation are shown positive.

Notes:

- The principle fixed axis is the illumination axis.
- The first axis is fixed perpendicular to the plane containing the observation and illumination axis.
- The reference axis is fixed in the retro-reflective material and moveable with β_1 and β_2 .

RETRO-REFLECTION (GRE)

(UN Reg. Nos. 3) means the reflection in which light is reflected in directions close to the direction from which it came. This property is maintained over wide variations of the illumination angle.

(UN Reg. Nos. 69 and 70) reflection in which radiation is returned in directions close to the direction from which it came, this property being maintained even over wide variations of the direction of the incident radiation.

(UN Reg. Nos. 104) means the reflection in which luminous flux is returned in directions close to the direction from which it came, this property being maintained even over wide variations of the direction of the luminous flux.

RETRO-REFLECTOR (GRE)

(UN Reg. Nos. 48 and 104,) means a device used to indicate the presence of a vehicle by the reflection of light emanating from a light source not connected to the vehicle, the observer being situated near the source.

The following are not considered as retro-reflectors:

- Retro-reflecting number plates.
- The retro-reflecting signals mentioned in the ADR (European Agreement concerning the international carriage of dangerous goods by road).
- Other retro-reflective plates and signals which shall be used to comply with national requirements for use as regards certain categories of vehicles or certain methods of operation.
- Retro-Reflecting materials approved as Class D or E and used for other purposes in compliance with national requirements.

(UN Reg. Nos. 50, 53, 74 and 113) means a device used to indicate the presence of a vehicle by the reflection of light emanating from a light source not connected to the vehicle, the observer being situated near the source. Retro-reflecting number plates are not considered as retro-reflectors.

(UN Reg. Nos. 86) means a device used to indicate the presence of a tractor by reflection of light emanating from a light source unconnected with the vehicle, the observer being situated near that source. For the purpose of this Regulation, the following are not considered as retro-reflectors:

- Retro-reflecting number plates.

- Other plates and retro-reflecting signals which must be used to comply with a Contracting Party's specifications for use as regards certain categories of vehicles or certain methods of operation.

REVERSING LAMP (GRE)

(UN Reg. Nos. 23 and 48) means the lamp used to illuminate the road to the rear of the vehicle and to warn other road-users that the vehicle is reversing or about to reverse.

(UN Reg. Nos. 86) means the lamp used to illuminate the road to the rear of the tractor and to warn other road-users that the tractor is reversing or about to reverse.

SAMPLE UNIT (GRE)

(UN Reg. Nos. 69) a complete, finished slow-moving vehicles plate ready to be mounted on a vehicle and representative of current production.

(UN Reg. Nos. 70) it is a complete, finished marking plate ready to be mounted on a vehicle and representative of current production.

(UN Reg. Nos. 104) means part or all of the retro-reflective material intended to be used to achieve the markings.

SECOND COMPONENT OF THE ENTRANCE ANGLE (symbol β_2) (GRE)

(UN Reg. Nos. 69, 70 and 88) means the angle from the plane containing the observation half-plane to the reference axis.

Range: $-90 \leq \beta_2 \leq 90^\circ$.

(UN Reg. Nos. 104) means the angle from the plane containing the observation half-plane to the reference axis.

Range $-90^\circ < \beta_2 < 90^\circ$.

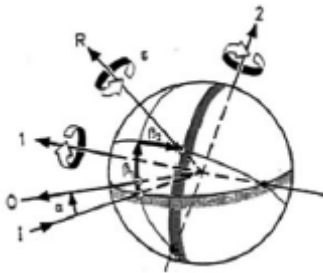

The CIE co-ordinate system

1: First Axis

2: Second Axis

I: Illumination Axis

O: Observation Axis

R: Reference Axis

α : Observation angle

β_1, β_2 : Entrance angles

ϵ : Rotation angle

The CIE angular system for specifying and measuring retro-reflective marking materials. The first axis is perpendicular to the plane containing the observation axis and the illumination axis. The second axis is perpendicular both to the first axis and to the reference axis. All axes, angles, and directions of rotation are shown positive.

Notes:

- The principle fixed axis is the illumination axis.
- The first axis is fixed perpendicular to the plane containing the observation and illumination axis.
- The reference axis is fixed in the retro-reflective material and moveable with β_1 and β_2 .

SINGLE LAMP (GRE)

(UN Reg. Nos. 48, 65, 77, 87, 91, 98, 112 and 123) means:

- A device or part of a device having one lighting or light-signalling function, one or more light source(s) and one apparent surface in the direction of the reference axis, which may be a continuous surface or composed of two or more distinct parts.

- Any assembly of two independent lamps, whether identical or not, having the same function, both approved as type “D” lamp and installed so that:
 - i. The projection of their apparent surfaces in the direction of the reference axis occupies not less than 60 per cent of the smallest quadrilateral circumscribing the projections of the said apparent surfaces in the direction of the reference axis.
 - ii. The distance between two adjacent/tangential distinct parts does not exceed 15 mm when measured perpendicularly to the reference axis.
- Any assembly of two independent retro-reflectors, whether identical or not, that have been approved separately and are installed in such a way that:
 - iii. The projection of their apparent surfaces in the direction of the reference axis occupies not less 60 per cent of the smallest quadrilateral circumscribing the projections of the said apparent surfaces in the direction of the reference axis.
 - iv. The distance between two adjacent/tangential distinct parts does not exceed 15 mm when measured perpendicularly to the reference axis.
- Any interdependent lamp system composed of two or three interdependent lamps providing the same function, approved together as type “Y” and installed so that the distance between adjacent apparent surfaces in the direction of the reference axis does not exceed 75 mm when measured perpendicularly to the reference axis.

(UN Reg. Nos. 50, 53, 74 and 113) means a device or part of a device, having one function and one apparent surface in the direction of the reference axis and one or more light sources.

For the purpose of installation on a vehicle, a “single lamp” also means any assembly of two independent or grouped lamps, whether identical or not, having the same function, if they are installed so that the projection of their apparent surfaces in the direction of the reference axis occupies not less than 60 per cent of the smallest rectangle circumscribing the projections of the said apparent surfaces in the direction of the reference axis. In such a case, each of these lamps shall, where approval is required, be approved as a type “D” lamp. This possible combination does not apply to driving beam headlamps and passing beam headlamps.

(UN Reg. Nos. 86) includes any combination of two or more lamps, whether identical or not, having the same function and colour, if it comprises devices, the projection of whose aggregate light-emitting surfaces in a given transverse plane occupies 60 per cent or more of the area of the smallest rectangle circumscribing the projections of the light-emitting surfaces of the aforementioned lamps, provided that such combination is, where approval is required, approved as a single lamp.

This possible combination does not apply to driving lamps, passing lamps, front fog lamps or lateral reflex reflectors.

STOP LAMP (GRE)

(UN Reg. Nos. 7) means the lamp used to indicate to other road-users to the rear of the vehicle that its driver is applying the service brake. The stop lamps may be activated by the application of a retarded or a similar device.

(UN Reg. Nos. 50, 53, 74 and 113) means the lamp used to indicate to other road-users to the rear of the vehicle that its driver is applying the service brake.

(UN Reg. Nos. 86) means the lamp used to indicate to other road-users to the rear of the tractor that the latter’s driver is applying the service brake.

TRANSVERSE PLANE (GRSP, GRSG, GRE)

(UN Reg. Nos. 17, 29, 32, 33, 34, 35, 48, 50, 53, 65, 74, 77, 87, 91, 95, 98, 104, 112, 113 and 123) means a vertical plane perpendicular to the median longitudinal plane of the vehicle.

(UN Reg. Nos. 86) means a vertical plane perpendicular to the median longitudinal plane of the tractor.

UNLADEN VEHICLE (GRSG, GRE)

(UN Reg. Nos. 39) means the vehicle in running order, complete with fuel, coolant, lubricant, tools and a spare wheel, if provided as standard equipment by the vehicle manufacturer, carrying a driver weighing 75 kg, but no driver’s mate, optional accessories or load.

(UN Reg. Nos. 48, 65, 77, 87, 91, 98, 104, 112 and 123) means a vehicle without driver, crew, passengers and load, but with a full supply of fuel, spare wheel and the tools normally carried.

(UN Reg. Nos. 50, 53 and 113) means a vehicle without a driver, or passenger, and unladen, but with its fuel tank full and its normal complement of tools.

(UN Reg. Nos. 93) means the vehicle in running order unoccupied and unladen but complete with fuel, coolant, lubricant, tools and a spare wheel, if provided as standard equipment by the vehicle manufacturer.