

---

## **Economic Commission for Europe**

### **Inland Transport Committee**

#### **World Forum for Harmonization of Vehicle Regulations**

##### **157<sup>th</sup> session**

Geneva, 26-29 June 2012

Item 2.2 of the provisional agenda

Programme of work, documentation and calendar of sessions for the year 2013

### **Templates for documents to be submitted to the Working Parties (GRs) and to the World Forum WP.29**

#### **Submitted by the secretariat**

The text reproduced below was prepared by the secretariat in order to provide to the participants of the GRs with a template for the preparation of official documents for the sessions of the GRs. It also contains a model of the proposals to be made for the presentation of a new UN Regulation or a consolidated text of an existing one.

To mark the proposed amendments to the existing text of the UN Regulations, UN Global Technical Regulations (UN GTRs) and UN Rules, the proposals for consideration by the GRs can be prepared either on track change mode or using bold text (for the additions) and strikethrough (for the deleted text).

This document is submitted to the World Forum for Harmonization of Vehicle Regulations for its consideration and possible adoption. If adopted, it will be posted at the WP.29 website, under the guidelines on preparing Working Party documents (<http://www.unece.org/trans/main/wp29/wp29wgs/wp29gen/wp29transsub.html>).



# Economic and Social Council

Distr.: General  
Date

Original: English

**Economic Commission for Europe** Normal 14 pt + Bold. Spacing: 6 pt Before/0 pt After

**Inland Transport Committee** Normal 14 pt Spacing: 6 pt Before/0 pt After

**World Forum for Harmonization of Vehicle Regulations** Normal 12 pt + Bold.  
Spacing: 6 pt Before/0 pt After

**Working Party on ..Use figures for sessions over ninety-nine** Normal 10 pt + Bold. Spacing: 6 pt B/0 pt A

**Forty-eighth session** Normal 10 pt + Bold. Spacing: 0 pt Before/0 pt After

Geneva, 7–10 December 2010 Normal 10 pt. Spacing: 0 pt Before/0 pt After

Item xx of the provisional agenda

**Global technical regulation No. x**

(xxxxxxxxxxxxxxxx)

**Proposal for amendments to Regulation No. xx .....\***  
**title of document: (\_H\_Ch\_G)**

**Submitted by the Chairman ..... origin of document: (\_H\_1\_G)**

This is a template of a working document using the New York format. You will find below examples of a proposal for amendments, a proposal for a revised or a new Regulation and a proposal of texts submitted by experts. At the end of this template, a table with the definitions of the New York styles can be found.

Examples of tables are given in page 7. Nevertheless, the format of tables can be adapted if needed.

The font used for editing formulas is Regular not Italic.

(\_Single Txt\_G)

\* In accordance with the programme of work of the Inland Transport Committee for 2010–2014

**Proposal for amendments**

Template

## I. Proposal (H\_Ch\_G)

Paragraph 2.16., amend to read: **\_Single Txt\_G: Normal + Indent: Left: 2 cm, Right: 2 cm, Justified, Space before/after: 0/6; Line spacing: at least 12, Hanging: 2 cm**

"2.16. "Standard reference test tyre" (SRTT) means a tyre that is produced, controlled and ....."  
**\_Single Txt\_G: Normal + Indent: Left: 2 cm, Right: 2 cm, Justified, Space before/after: 0/6; Line spacing: at least 12, Hanging: 2 cm**

Paragraph 2.17., amend to read:

"2.17. Wet Grip or Snow Grip measurements – Specific definitions"

Insert new paragraph 2.17.5., to read:

"2.17.5. "Snow grip index ("SG")" means ....."

Paragraphs 2.17.5. (former) to 2.17.7., renumber as paragraphs 2.17.6. to 2.17.8.

Paragraph 6.4., amend to read:

- "6.4. In order to be classified in the category of use "snow tyre", a tyre is required to meet performance requirements based on a test method by which:
- (a) The mean fully developed deceleration ("mfdd") in a braking test,
  - (b) Or alternatively an average traction force in a traction test, or alternatively (**Single txt G - Indent left 4 - Right 2 - Hanging 1**)
- The relative performance shall be indicated by a snow index."

## II. Justification (H\_Ch\_G)

1. The expert from.....  
.....

**Note: B. Justification is not mandatory.**

<p>To mark the proposed amendments to the existing text of the UN Regulations, UN Global Technical Regulations (UN GTRs) and UN Rules, the proposals for consideration by the GRs can be prepared either on track change mode or using bold text (for the additions) and strikethrough (for the deleted text).</p>
--

---

**Proposal for a revised or new Regulation**

Template

**Regulation No. xx**

**Title of the Regulation ..... (\_H\_Ch\_G)**

**Contents** *Table of Contents showing page only*

	<i>Page</i>
1. Scope.....	1
2. Definitions.....	3
3. Application for approval .....	4
4. Markings .....	5
5. Approval .....	6
6. General specifications .....	6
7. Tests .....	8
8. Test reports of type approval and of production qualification .....	9
9. Production qualification .....	10
.....	

**Annexes** (Numbers of annexes without point)

1 Communication.....	18
2 Arrangements of the approval mark.....	19
3 Arrangement of apparatus for dust resistance test.....	20
4 Corrosion Test.....	21
5 Abrasion and Microslip test .....	22
6 Description of Trolley .....	23
Appendix 1 .....	24
Appendix 2 - Arrangement and use of anchorages on the test trolley.....	25
Appendix 3 - Side impact and door panel description.....	26
7 Curve of trolleys deceleration or acceleration, as function of time .....	27
.....	

## 1. Scope (**\_H\_Ch\_G**)

This Regulation applies (in its Phase 1) to Integral Universal ISOFIX child restraint .....

*\_Single Txt\_G: Normal + Indent: Left: 2 cm, Right: 2 cm, Justified, Space before/after: 0/6; Line spacing: at least 12, Hanging: 2 cm*

## 2. Definitions (**\_H\_Ch\_G**)

For the purposes of this Regulation,

- 2.1. "*Child restraint system*" means a device offering the child occupant the possibility to sit on, to sit .....
- 2.2. "*Child restraint type*" means child restraint system which does not differ in such essential respects as:
- (a) Electrical isolation: protection against electric shock;
  - (b) Battery integrity: battery management system, robustness and survivability;(Single txt G - Indent left 4 - Right 2 - Hanging 1)
    - (i) Electrical isolation: protection against electric shock;
    - (ii) Battery integrity: battery management system, robustness and survivability;(Single txt G - Indent left 5 - Right 2 - Hanging 1)

## 3. General Specifications (**\_H\_Ch\_G**)

- 3.1. Positioning and securing on the vehicle.
- 3.1.1. The use of child restraint systems in the  $\textcircled{i}$ -Size category is permitted in  $\textcircled{i}$ -Size ready .....
- 3.1.2. According to the category which it belongs to, the child restraint system shall be secured .....

**(Formula in Regular font, not Italic)**

$$K_{w,r} = \left( 1 - \frac{1,2442 \times H_a + 111,19 \times w_{ALF} \times \frac{q_{mf}}{q_{mad}}}{773,4 + 1,2442 \times H_a + \frac{q_{mf}}{q_{mad}} \times k_f \times 1\,000} \right) \times 1,008$$

**Note: According to the UN Manual of editing, it is not allowed to have paragraph 0**

Table 1 (Heading 1, Table\_G)  
Possible configurations for type approval / Table of categories (Single txt\_G Bold)

Format of Table Text

Category	Supplement <i>Normal+8pt, Italic; before/after 4; Line Spacing: Exactly 10, Alignment: left + 0.2 indent left and right</i>	Period
C21W	28 <i>Normal+10pt, right indent: 0,2 cm, Space before/after: 2/6, Line Spacing: at least 12, Alignment left</i>	12 months
P19W	[37]	60 months
PC16W	[37]	60 months
PCR16W	[37]	12 months
PCY16W	[37]	60 months

3.2. Requirements for CRS support leg and vehicle floor support leg requirements  
.....

Table 2 (Heading 1, Table\_G)  
Geometrical dimensions of -Size child restraint systems (Single txt\_G Bold)

Format of table with figures

<i>Harmonic number*</i> <i>n</i>	<i>Maximum authorized harmonic current</i> <i>A</i>
<i>Normal+8pt, italics, Before/After: 4 pt; Line Spacing: Exactly 10pt. Alignment: right,</i>	
11 <i>Normal+9pt, Before/After: 2/2 pt; Line spacing: exactly 11pt, Alignment: right, cell margin right 0.2 cm</i>	0,33
13	0,21
$15 \leq n \leq 39$	$0,15 \times 15/n$
Even harmonics	
2	1,08
4	0,43
6	0,30
$8 \leq n \leq 40$	$0,23 \times 8/n$

\* Footnotes to tables should be created manually and should have the same width as the table:  
Footnote reference: **9 pt+italic+Superscript** Style: **Normal** Text: **9 pt** Para. Spacing: **0/0** Line spacing: **Exactly 11 pt** Alignment: **Left** Indent: **first line 0.3 cm** After reference footnote: **2 spaces**.

**Note:** The format of tables can be adapted if needed, depending on the content and complexity of the table. Three possible layouts for portrait tables: Width 13 cm; Indent from left: 2 cm / Width 15 cm; Indent from left: 2 cm / Width 17 cm; Indent from left: 0 cm.



**Annex 1 (\_H\_Ch\_G)****Communication (\_H\_Ch\_G)**

(Maximum format: A4 (210 x 297 mm))



issued by :

(Name of administration)

.....

.....

.....

**Footnote No. 1 to the left of the figure in white colour to have automatic number**

concerning<sup>2</sup>:      Approval granted  
                          Approval extended  
                          Approval refused  
                          Approval withdrawn  
                          Production definitively discontinued

of restraining devices for child occupants of power-driven vehicles, pursuant to Regulation No. 44.

Approval No.: .....

Extension No.: .....

1.    Manufacturer's name or trade mark(s) on the tyre type:  
       .....
2.    Tyre type designation by the manufacturer
3.    Manufacturer's name and address .....
4.    If applicable, name and address of manufacturer's representative .....
5.    Summarized description:.....

<sup>1</sup> Distinguishing number of the country which has granted/extended/refused/withdrawn approval (see approval provisions in the Regulation).

<sup>2</sup> Strike out what does not apply

## Annex 2 -Appendix 1 (\_H\_Ch\_G)

Figure 1 (Heading 1; Table\_G)  
Dimensions of the seat and the seat cushions

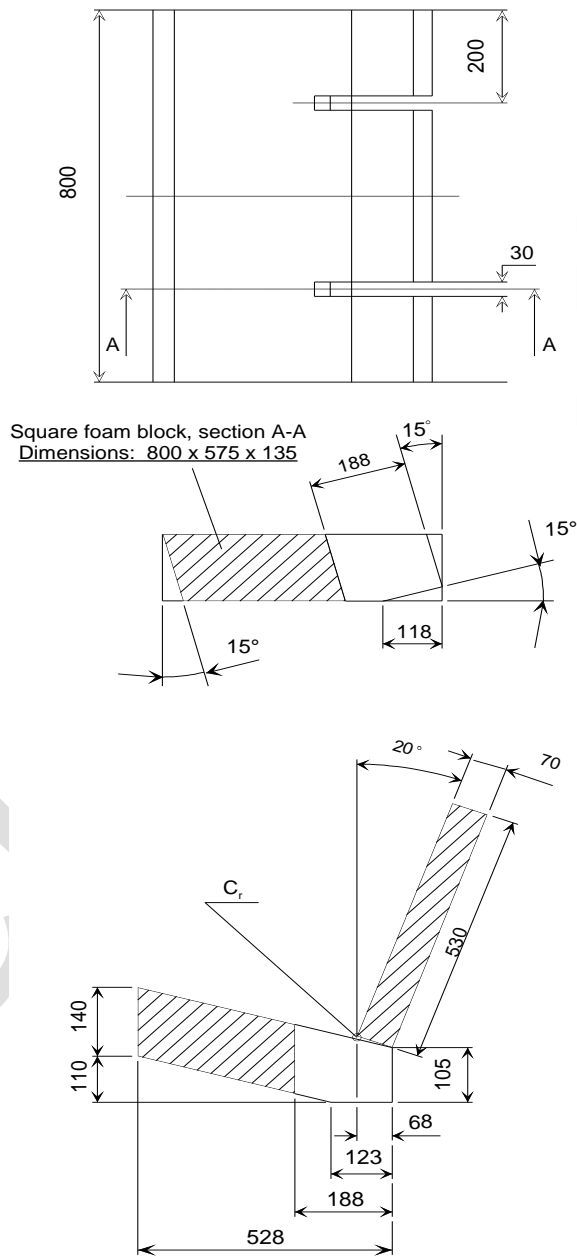

## Annex 2 - Appendix 2 (H\_Ch\_G)

### Arrangement and use of anchorages on the test trolley (H\_Ch\_G)

1. The anchorages shall be positioned as shown in the figure below.  
When attaching the standard anchorage plate to the anchorage points A and B or B0 the.....
  - (a) Identify potential safety risks specific to EVs taking account of the actual use in the market; (Single txt G - Indent left 4 - Right 2 - Hanging 1)
  - (b) Develop and evaluate the requirements by reviewing analyses and evaluations conducted to justify the requirements; (Single txt G - Indent left 4 - Right 2 - Hanging 1)
    - (i) Electrical isolation: protection against electric shock;
    - (ii) Battery integrity: battery management system, robustness and survivability; (Single txt G - Indent left 5 - Right 2 - Hanging 1)
2. Child restraints in the "universal" and "restricted" categories shall use the following anchorage points:
  - 2.1. For child restraint using lap belts, points A and B;
  - 2.2. For child restraint using lap and diagonal belts, points A, B0 and C;
  - 2.3. For child restraints using ISOFIX attachment, rearmost point H1 and H2.

**Proposal of a text submitted by an expert**

Template

## Title (H\_Ch\_G)

### A. Introduction (H\_1\_G)

1. The proposal for setting up two informal working groups on electric vehicles<sup>1</sup> (EVs) comes at the initiative of the European Commission, DG Enterprise and Industry, ..... (Single txt G)
2. Through this initiative, the co-sponsors aim to:
  - (a) Exchange information on current and future regulatory requirements for electric vehicles in different markets, (Single txt G - Indent left 3 - Right 2 - Hanging 1)
  - (b) Where possible, develop common requirements in the form of one or more UN global technical regulations (gtr) 3. Both working groups should be established under the 1998 Agreement to create the basis for the possible .....

### B. Areas of work in two informal working groups (H\_1\_G)

4. The two key topics for the informal working groups are safety requirements and environmental performance .....

#### 1. Informal Working Group on Electric Vehicles Safety (EVS) (H\_2/3\_G)

5. The aim of this working group is to sponsor an effort to develop one gtr (or more, if appropriate) to address the safety of EVs<sup>2</sup>.....:
  - (a) In-use: (Single txt G - Indent left 3 - Right 2 - Hanging 1)
    - (i) Occupant protection: protection against electric shock; (Single txt G - Indent left 4 - Right 2 - Hanging 1)
    - (ii) Safety requirements for RESS, including battery safety (battery management system, thermal shock, thermal cycling, mechanical shock, overcharge/isolation resistance, over-charge, vibration, fire resistance and short circuit, etc.);
  - (b) Post-crash: (Single txt G - Indent left 3 - Right 2 - Hanging 1)

#### 2. Informal Working Group on Electric Vehicles and Environment (EVE) (H\_2/3\_G)

7. The informal working group on Electric Vehicles and the Environment would be an open structure .....

<sup>1</sup> The term and the work in the groups will cover both battery electric (BEV) and hybrid electric vehicles (HEV) (including plug-in hybrids (PHEV)).

<sup>2</sup> The work already accomplished under the 1958 Agreement could be an important input, notably the Regulation 100, 12, ..... Footnote Text,5\_G

**C. Existing regulations and directives: (\_H\_1\_G)**

14. At present time there are no regulations concerning electric vehicle safety in the Compendium of .....

**Regulations and directives: (\_H\_2/3\_G)**

United States -- FMVSS 305 – Electric-Powered Vehicles: Electrolyte Spillage and Electrical Shock Protection (Bullet 1 G)

ECE – Regulation 12 – Uniform Provisions Concerning The Approval Of Vehicles With Regard To The Protection Of The Driver Against The Steering Mechanism In The Event Of Impact

ECE – Regulation 94 – Uniform Provisions Concerning The Approval Of Vehicles With Regard To The Protection Of The Occupants In The Event Of A Frontal Collision

**Environment (\_H\_2/3\_G)**

USA: U.S. Code of Federal Regulations (CFR) Title 40: Protection of the Environment; .....

EU: Regulation (EC) No. 715/2007 on type approval of motor vehicles with respect .....

Regulation (EC) No. 595/2009 on type-approval of motor vehicles and engines with respect.....

**D. Timeline (\_H\_1\_G)**

**January 2012:** feedback of other parties interested to join the group on the proposal.

**13-16 March 2012:** official adoption of the decision to launch the two informal WG by WP.29 in Geneva, chairs and secretaries are elected.

**March 2012:** first meetings of the two informal WGs

**Spring 2012,** adoption of Terms of Reference for each informal WG by the GRPE and GRSP, respectively.

---

## Definition of styles

### 1. Text

Normal	<b>Font:</b> TNR 10 <b>Tabs:</b> 1 cm (by default) <b>Paragraph:</b> Alignment: Left; Line Spacing: At least 12 pt; Space: Before 0 pt, After 0 pt
_Single Txt_G	<b>Based on:</b> Normal <b>Font:</b> 10 pt <b>Tabs:</b> 1 cm (by default) <b>Paragraph:</b> Alignment: Justified; Line Spacing: At Least 12 pt; Space: Before 0 pt, After 6 pt; Left Margin: 2 cm; Right Margin: 2 cm
• _Bullet 1_G	<b>Based on:</b> Normal <b>Tabs:</b> 3 cm Left <b>Paragraph:</b> Alignment: Justified; Line Spacing: At Least 12 pt; Left Margin: 2.7 cm; Indent Hanging 0.3 cm; Right Margin: 2 cm; Space: Before 0 pt, After 6pt;
• _Bullet 2_G	<b>Based on:</b> Normal <b>Tabs:</b> 4 cm Left <b>Paragraph:</b> Alignment: Justified; Line Spacing: At Least 12 pt; Left Margin: 3.7 cm; Indent Hanging 0.3 cm; Right Margin: 2 cm; Space: Before 0 pt, After 6pt;
<b><u>Header.6_G</u></b>	<b>Based on:</b> Normal <b>Font:</b> 9 pt, Bold <b>Paragraph:</b> Line Spacing: single; <b>Border:</b> Bottom (single, Auto, Line width 0.5 pt; From text: 4 pt border spacing)
Heading 1,Table_G	<b>Based on:</b> _Single Txt_G <b>Font:</b> 10 pt <b>Paragraph:</b> Line spacing: Single
Footer,3_G	<b>Based on:</b> Normal <b>Font:</b> 8 pt <b>Paragraph:</b> Line spacing: Single
Footnote Reference,4_G	<b>Based on:</b> Normal <b>Font:</b> 9 pt; Superscript
Footnote Text,5_G	<b>Based on:</b> Normal <b>Font:</b> 9 pt <b>Tabs:</b> 1.8 cm Right <b>Paragraph:</b> Alignment: Left; Line spacing: Exactly 11 pt; Indent Hanging: 2 cm; Space: After 0 pt; Left Margin: 0 cm; Right Margin: 2 cm;
Endnote Reference,1_G	<b>Based on:</b> Normal <b>Font:</b> 9 pt; Superscript
Endnote Text,2_G	<b>Based on:</b> Footnote Text,5_G
<b>Page Number,7_G</b>	<b>Based on:</b> Normal <b>Font:</b> 9 pt; Bold

## 2. Headings

<b>_H_M_G</b>	Main Heading	<b>Based on:</b> Normal Font: 17 pt Bold <b>Tabs:</b> 1.5 Right <b>Paragraph:</b> Line Spacing: Exactly 18 pt; Indent Hanging 2 cm; Space: Before 12pt, After 12pt; Margins:
<b>_H_Ch_G</b>	Chapter Heading	<b>Based on:</b> Normal Font: 14 pt Bold <b>Tabs:</b> 1.5 Right <b>Paragraph:</b> Line Spacing: Exactly 15 pt; Indent Hanging 2 cm; Space: Before 18pt, After 12pt; Margins:
<b>_H_1_G</b>	Heading 1	<b>Based on:</b> Normal Font: 12 pt Bold <b>Tabs:</b> 1.5 Right <b>Paragraph:</b> Line Spacing: Exactly 13.5 pt; Indent Hanging 2 cm; Space: Before 18pt, After 12pt; ; Margins: L 0 cm;
<b>_H_2/3_G</b>	Heading 2/3	<b>Based on:</b> Normal Font: 10 pt Bold <b>Tabs:</b> 1.5 Right <b>Paragraph:</b> Line Spacing: Exactly 12 pt; Indent Hanging 2 cm; Space: Before 12pt, After 6pt; ; Margins:
<b>_H_4_G</b>	Heading 4	<b>Based on:</b> Normal Font: 10 pt <i>Italics</i> <b>Tabs:</b> 1.5 Right <b>Paragraph:</b> Line Spacing: Exactly 12 pt; Indent Hanging 2 cm; Space: Before 12pt, After 6pt; Margins: L
<b>_H_5/6_G</b>	Heading 5/6	<b>Based on:</b> Normal <b>Font:</b> 10 pt <b>Tabs:</b> 1.5 Right <b>Paragraph:</b> Line Spacing: Exactly 12 pt; Indent Hanging 2 cm; Space: Before 12pt, After 6pt; ; Margins: L 0 cm; R 2 cm Keep with



Use/Usage This list is not exhaustive and will be completed as needed / Cette liste n'est pas exhaustive et sera complétée si besoin est	
<u>ENGLISH</u>	<u>FRENCH</u>
<b>Abbreviations</b> and <b>acronyms</b> are <b>not used in titles</b>	Les <b>abréviations</b> et les <b>acronymes</b> <b>ne sont pas utilisés dans les titres</b>
<b>Figure, in the text</b> <b>Figure 1</b> with CAPS	<b>Figure dans le texte</b> <b>figure 1</b> f minuscule
<b>Formulas</b> Formulas shall be written in <b>Regular font (NOT in Italic font)</b> .	<b>Formules</b> Les formules doivent être dactylographiées en <b>caractères droits et non pas en italique</b>
<b>Item</b> When we refer to the formulaire of "Communication" (usually Annex 1), we use " <b>item</b> " instead of "paragraph"	<b>Point</b> Lorsque l'on se réfère au formulaire Communication (habituellement Annexe 1) on emploie le terme « <b>point</b> » au lieu de «paragraphe»
<b>Per cent</b> in the text <b>% only in the tables</b>	<b>% s'utilise dans le texte et les tableaux</b>
<b>Punctuation of figures</b> English: <b>2,632,597</b> Decimals: <b>178.40</b>	<b>Ponctuation des chiffres:</b> Français: <b>2 632 597</b> Décimales: <b>178,40</b>
<b>Quotations: "straight quotes"</b>	<b>Guillemets :«Guillemets»</b>
<b>Space for ±</b> <b>10 ± 10</b> (space before and after) But <b>±10</b> no space Please, <b>don't use the sign + underlined. Use ± Insert-Symbol</b>	<b>Espace pour ±</b> <b>10 ± 10</b> (espace avant et après) Mais <b>±10</b> pas d'espace <b>Ne pas utiliser le signe + souligné. Insérer ± avec Insert-Symbol</b>
Technical <b>S</b> ervices	Services <b>t</b> echniques
<b>Passing-beam / Driving-beam / Main-beam / Dipped-beam:</b> with -	
<b>Sub-paragraphs</b> <b>(a) (b) (i) (ii)</b>	<b>Alinéas</b> <b>a) b) i) ii)</b>