

Distr.: Restricted
10 April 2012

Original: English

**Group of Experts for the revision of the IMO/ILO/UNECE
Guidelines for Packing of Cargo Transport Units**

Second session

Geneva, 19-20 April 2012

Item 3 of the provisional agenda

Updates on the 1st draft of the Code of Practice (COP)

**Proposed amendments (World Shipping Council) submitted
on the Code of Practice for packing of Cargo Transport Units
(CTU Code)**

Note by the Secretariat

1. Per the Secretariat request on 21 March, 2012 to the Group of Expert on submitting comments and suggestions on the circulated draft COP in advance to the second session of the Group of Experts (19-20 April, 2012), the Group of Experts may wish to consider the proposed amendments from the World Shipping Council reproduced below, and decide as appropriate.

**Proposed amendments on the Code of Practice for Packing of Cargo
Transport Units (CTUs) (CTU Code)**

**Lars Kjaer
World Shipping Council
1156 15th Street, NW
Suite 300, Washington, DC
20005 USA
www.worldshipping.org**

Code of Practice for Packing of Cargo Transport Units (CTUs) (CTU Code)

Acknowledgements

Forward

Contents

- 1.0 Introduction
 - 1.1 Preamble
 - 1.2 Scope
 - 1.3 How to use the Code of Practice
- 2.0 Key requirements
 - 2.1 Introduction
 - 2.2 Planning
 - 2.3 Other regulations and conventions
 - 2.4
 - 2.5
- 3.0 Consequences of badly packed and secured cargo
 - 3.1 Need for cargo securing
 - 3.2 blank¹
 - 3.3 Mass declaration
 - 3.4 Concentrated loads
- 4.0 General transport conditions
 - 4.1 All modes
 - 4.2 blank
 - 4.3 blank
 - 4.4 blank
 - 4.5 blank
 - 4.6 Road
 - 4.7 Rail
 - 4.8 Maritime
- 5.0 CTU properties
 - 5.1 Containers
 - 5.2 Swap bodies
 - 5.3 Domestic and regional containers
 - 5.4 Road vehicles
 - 5.5 Rail wagons
- 6.0 Responsibilities and Information chains

¹ blank refers to a paragraph that has no heading and which will be resolved after the first draft is considered.

- 6.1 Chain of Responsibility
- 6.2 Chain of Information

Main Section

- 7.0 Chain of Responsibilities
 - 7.1 Consignor / Packer
 - 7.2 Consolidator / Packer
 - 7.3 Freight Forwarder
 - 7.4 Road Carrier
 - 7.5 Rail Carrier
 - 7.6 Terminal and stevedore
 - 7.7 Maritime Carrier
 - 7.8 Consignee
- 8.0 Chain of Information
 - 8.1 Information necessary for safe transport
 - 8.2 Information flow paths
 - 8.3 CTU information circulation
 - 8.4 CTU information timing
- 9.0 Suitability of CTU
 - 9.1 Cargo to be carried
 - 9.2 Transport route
 - 9.3 Security
 - 9.4 Transport Modes
 - 9.5 Handling
- 10.0 Before packing CTUs
 - 10.1 blank
 - 10.2 blank
 - 10.3 CTU arrival
 - 10.4 CTU checks
 - 10.4.1 Exterior checks
 - 10.4.2 Interior checks
 - 10.4.3 Safety and biotic checks
 - 10.4.4 Serious structural deficiencies
 - 10.5 Positioning CTU for packing
- 11.0 Packing cargo
 - 11.1 blank
 - 11.2 Understanding stresses

- 11.3 Packing planning
- 11.4 Accredited Packer
- 11.5 Entering the CTU
- 11.6 Safe Fork Truck use
- 11.7 Manual Handling
- 11.8 Securing materials
 - 11.8.1 Dunnage
 - 11.8.2 Fibre ropes
 - 11.8.3 Steel ropes
 - 11.8.4 Wire rope lashing
 - 11.8.5 Steel strapping / banding
 - 11.8.6 Lashing chains
 - 11.8.7 Lashing belts
- 11.9 Basic principles for packing and securing
 - Terminology
 - General techniques
 - Blocking
 - Bracing
 - Lashing
 - CTU with solid walls
 - CTU with flexible walls
 - CTU without walls
- 11.10 Load distribution
- 11.11 Packing bulk materials
 - 11.11.1 Portable Tanks
 - 11.11.2 Dry tanks
- 12.0 Additional advice on the packing dangerous goods
- 12.1 General
- 12.2 Before packing
- 12.3 Packing
- 13.0 On completion of packing
- 13.1 Closing the CTU
 - 13.1.1 Final checks
 - 13.1.2 Fitting seals
- 13.2 Marking and placarding
- 13.3 Documentation
 - 13.3.1 Customs and security

- 13.3.2 Dangerous Goods
- 13.3.3 Documentation
- 13.3.4 Marking
- 13.3.5 Documentation (to be considered with 11.2.3 above)
- 14.0 Basic principles for the safe handling and securing of CTUs
 - 14.1 General
 - 14.2 Lifting
 - 14.3 CTUs on the ground
 - 14.4 Handling CTUs
 - 14.5 CTUs on vehicles
 - 14.6 CTUs on rail wagons
 - 14.7 CTUs on Ships
- 15.0 In shipment cargo inspections
- 16.0 Advice on receipt and unpacking of CTUs
 - 16.1 Opening CTUs
 - 16.2 Unpacking
 - 16.3 Cleaning
 - 16.4 Environmental disposal of dunnage
 - 16.5 Reporting
- 17.0 CTU deficiencies
 - 17.1 CTU structural deficiencies
 - 17.2 Packing deficiencies
 - 17.3 Load deficiencies
 - 17.4 Consequences of deficiencies
 - 17.5 Insurance
- 18.0 Training in packing of cargo in CTUs
 - 18.1 Regulatory authorities
 - 18.2 Management
 - 18.3 Personnel
 - 18.4 Training
 - 18.5 Recommended course syllabus – overview

Annexes

- 1.0 Acronyms
- 2.0 Definitions
 - 2.1 Packing terms

- 2.2 Shipment Terms
- 2.3 CTU terms
- 3.0 CTU types
 - 3.1.1 ISO Containers
 - 3.1.2 Swap bodies (see below)
 - 3.1.3 Road vehicles (in the wrong place)
 - 3.1.4 Tank containers
 - Named containers (numbered 3.4.12 – should be 3.5 - incorrect numbering)
 - 3.1.5 Swap bodies (this is the correct place)
 - 3.1.6 Regional or domestic containers
 - 3.1.7 Rail wagons
- 4.0 Avoiding condensation
- 5.0 Securing Techniques
 - Detailed securing techniques similar to Container Handbook.
- 6.0 Lashing Requirements
 - Detailed description of lashing forces and number of straps / lashings etc.
- 7.0 Friction and safety factor
 - (Text drawn from Model Course and CSS Code if required for certain types of CTU)
- 8.0 Other Regulations and Conventions
 - 8.1 Customs Convention for Containers
 - 8.2 International Convention for Safe Containers
 - 8.3 IMDG Code
 - 8.4 Rotterdam Rules
 - 8.5 TIR
 - 8.6 others
- 9.0 List of relevant international organisations
- 10.0 Topics to be included in a training programme for the packing and securing of cargoes in cargo transports units (CTUs)

Code of Practice for Packing of Cargo Transport Units (CTUs) (CTU Code)

Introduction Section

Acknowledgements

Forward

Contents

1.0 Introduction

1.1 Preamble

1.1.1 While the use of freight containers, swap-bodies, vehicles or other cargo transport units substantially reduces the physical hazards to which cargoes are exposed, improper or careless packing of cargoes into/onto such units, or lack of proper blocking, bracing and securing, may be the cause of personnel injury when they are handled or transported. In addition, serious and costly damage may occur to the cargo or to the equipment, and the safety of ships and other conveyances and their crew may be put at risk. The person who packs and secures cargo into/onto the cargo transport unit (CTU) may be the last person to look inside the unit until it is opened by the consignee at its final destination.

1.1.2 Consequently, a great many people in the transport chain will rely on the skill of such persons, including:

- .1 road vehicle drivers and other highway users when the unit is transported;
- .2 rail workers, and others, when the unit is transported by rail;
- .3 crew members of inland waterway vessels when the unit is transported on inland waterways;
- .4 handling staff at inland terminals when the unit is transferred from one transport mode to another;
- .5 dock workers when the unit is loaded or discharged;
- .6 crew members of the ship which may be taking the unit through its most severe conditions during the transport operation; and
- .7 those who unpack the unit.

1.1.3 All persons, such as the above and passengers, may be at risk from a poorly packed container, swap-body or vehicle, particularly one which is carrying dangerous cargoes.

1.2 Scope

1.2.1 This Code of Practice (Packing Code) is essential to the safe packing of cargo transport units by those responsible for the packing and securing of the cargo and by those whose task it is to train people to pack such units. However, they are not exhaustive and other sources of information may be relevant. Training is essential if safety standards are to be maintained. The Packing Code details practical measures to ensure the safe packing of cargo onto or into cargo transport units. ~~As such they are concerned with issues of safety and are not intended to address practical measures to enhance security, per se. [This sentence should become new, first sentence in 11.2.3 below]~~

Formatted: Highlight

1.2.2 The Packing Code is not intended to conflict with, or to replace or supersede, any existing regulations or recommendations which may concern the carriage of cargo in cargo transport units. While previous versions of the Packing Code did not cover the filling or emptying of tank containers, portable tanks or road tank vehicles, or the transport of any cargo in bulk containers, all of these CTU types will be addressed within the Packing Code.

~~1.2.3 11.2.3 The Packing Code is concerned with issues of safety, not with conveyance and cargo security. However, it is extremely important that all personnel involved in the packing, sealing, handling, transport and processing of cargo should be made aware of the need for vigilance and the diligent application of legal requirements and practical procedures to enhance security, in accordance with national legislation and international agreements. Guidance on the security aspects of the movement of cargo transport units intended for carriage by sea may be found in a variety of documents including the International Convention for the Safety of Life at Sea (SOLAS), 1974, as amended; the International Ship and Port Facility Security (ISPS) Code; and the ILO/IMO Code of Practice on Security in Ports; and the Standards and the Publicly Available Specifications developed or being developed by the International Standards Organization (ISO) to address cargo security management and other aspects of supply chain security. Furthermore, the World Customs Organization (WCO) has developed a SAFE Framework of standards to secure and facilitate global trade. In addition, the International Standards Organization (ISO) has developed standards and specifications in support of these instruments. [COMMENT: Exactly because the primary focus of the COP is safety, not security, it should only include a brief reference to security].~~

~~1.2.4 However, it is important to bear in mind that all personnel involved in the transport chain have a significant role to play enhancing safety and security, not only in the prevention of unlawful acts. Significant financial losses are incurred through theft of cargo and the costs must ultimately be borne by customers and end users through increased insurance and transport costs. The trafficking of illicit drugs has a detrimental effect on society. The movement of weapons in contravention of national laws and internationally agreed arms embargoes; the illegal migration and human trafficking; the smuggling of nuclear materials and precursors for weapons of mass destruction; protection of national revenues; environmental and cultural concerns, and the need to deprive terrorist organizations of funding are all issues of relevance to the transport of cargo transport units. Furthermore, cargo handlers' and transporters' lives are lost and environments are damaged through the transport of undeclared, improperly described and unsafely packed dangerous goods.~~

~~10.1.1 It is therefore, extremely important that all personnel involved in the packing, security sealing, handling, transport and processing of cargo should be made aware of the need for vigilance and the diligent application of practical procedures to enhance security, in accordance with national legislation and international agreements.~~

Formatted: Outline numbered +
Level: 3 + Numbering Style: 1, 2, 3, ...
+ Start at: 1 + Alignment: Left +
Aligned at: 0 cm + Tab after: 2.5 cm
+ Indent at: 1.5 cm

1.3 How to use the Code of Practice

1.3.1 This code of practice is split into three sections:

.1 An introduction to the Code.

Sections 1.0 to 6.0 provide the user with an overview of the Packing Code. Many of the subjects covered in the introduction will be covered in greater detail in the main section of the Packing Code.

.2 Main Section to the Code

Sections 7.0 to 18.0 provide the user with detailed guidance and recommendations for all those involved within the supply chain. While the majority of the Packing Code concerns the responsibilities and roles of those involved with packing the CTU, there are additional sections covering safety, security and best practices for handling and transporting CTUs.

.3 Appendices

The Appendices provide the user with specific information about a number of subjects related to packing and transport of CTUs. The subject will be covered in greater detail and provide such as:

- Acronyms,
- Definitions,
- CTU equipment types,
- Packing and securing procedures,
- Lashing equipment and strengths.

1.3.2 Each of these sections has been written to meet the requirements of the different roles undertaken by those involved in the supply chain. Subjects within the Introduction are cross-referenced to sections within the main section to the Code.

~~1.3.3 This document is a non-regulatory Code of Practice which means that the Code is not backed by an international convention or regulation. [COMMENT: This paragraph is not needed. The non-mandatory nature of the COP is self-evident. Besides, the paragraph as currently drafted sends the exact opposite message than intended when the decision was made to turn the existing Guidelines into a COP].~~

~~1.3.41.3.3~~

2.0 Key requirements

2.1 The section outlines the key requirements for planning, packing and securing, handling and transport and unpacking cargo transport units. The points raised are covered in more detail in sections 11.0 and 14.016.0

2.2 Planning

- .1 Do select the most suitable container type to accommodate the cargo (see appendix 3);
- .2 Do prepare a packing plan showing each package (dimensions and mass) (see **Error! Reference source not found.**) which distributes the mass of the cargo evenly over the floor / deck of the CTU;
- .3 Wherever possible use a block stow when planning the packing of regular packages. If there are insufficient packages to complete full layers fully secure the top layers. Do not build up irregular layers;

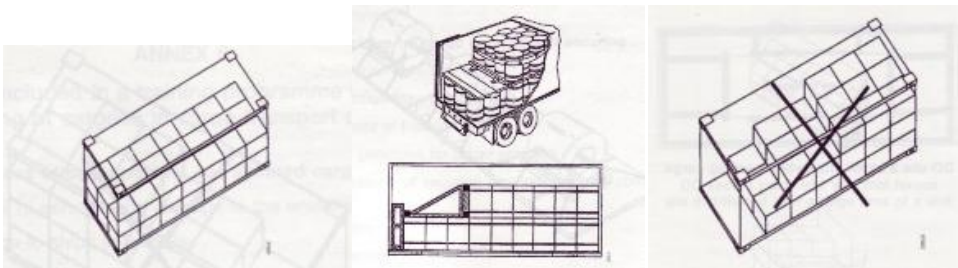

- .4 Do keep the centre of gravity as low as possible and distribute individual packages so that the centre of gravity is above the diagonal centre of the CTU - If this is not possible

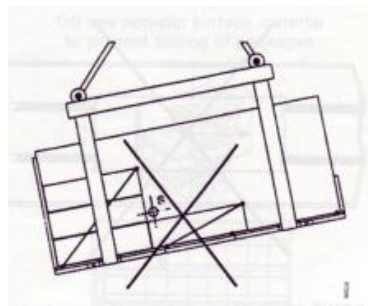

ensure that the eccentricity is less than 5% (see..);

If the CTU is to travel by road, ensure that the packing plan distributes the load in line with the load distribution plan, so that individual axles are neither over nor under loaded;

- .5 Don't stow heavy goods on top of light goods;
- .6 Don't pack heavy loads with a small footprint unless the load is spread over a wide area. Allow sufficient space in the plan for the load distribution bearers;

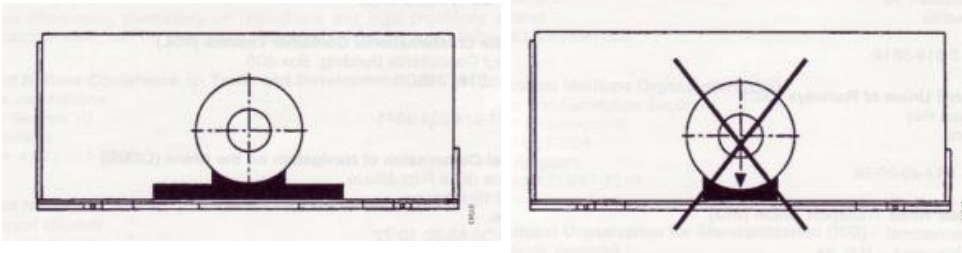

- .7 Where possible with mixed loads, prepare a plan where packages containing liquid cargo on the bottom tiers with dry cargo on top;
- .8 Do not stow goods with tainting odours with sensitive merchandise;
- .9 Pack hazardous cargo near the door where possible;
- .10

2.2.2 Packing and securing

- .1 Before packing commences, check that the CTU and any load securing equipment are in sound and serviceable condition (see 10.4);
- .2 Observe all the handling instructions on packages such as "Do not drop" or "This side up" and do not pack if the packaging is damaged;
- .3 Use cargo liners for obnoxious cargo such as hides and carbon black;
- .4 Do not use clamps or other loading devices unless the goods can withstand them;
- .5 Do not pack wet and damp goods with dry goods;
- .6 Observe all rules concerning dangerous cargo. Use appropriate labels and placards to identify packing and freight containers loaded with Dangerous Goods;
- .7 Determine the securing method(s) best adapted to the characteristics of the packages (bracing, locking, blocking, direct lashing, over-the-top lashing, or any combination.);
- .8 Protect the CTU and other packages from goods with sharp corners. Use dividers and separating material as appropriate;
- .9 Wherever possible use equipment which supports the securing such as friction mats, walking boards, straps, edge beams, etc.;
- .10 Do not use dunnage or packaging which is incompatible with the cargo;

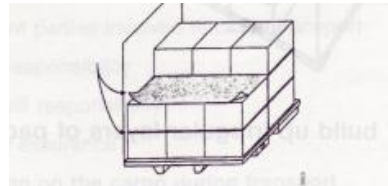

- .11 Ensure that the securing equipment is commensurate with the constraints it will encounter during the whole journey. Emergency braking, strong cornering to avoid an obstacle, bad road or weather conditions have to be considered as normal circumstances likely to happen during a journey and the securing methods employed must be capable of retaining all packages;
- .12 Do secure loads in a way that forces are distributed over a large area of a unit and not concentrated onto small areas within the CTU;

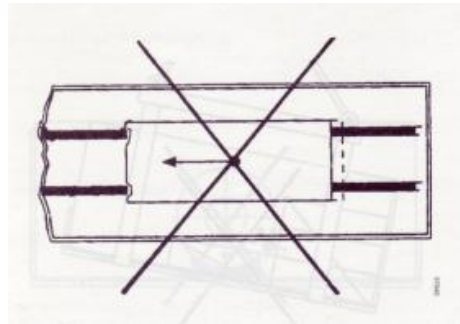
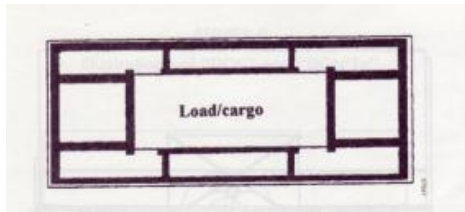

- .13 Do secure each single loaded items independently;

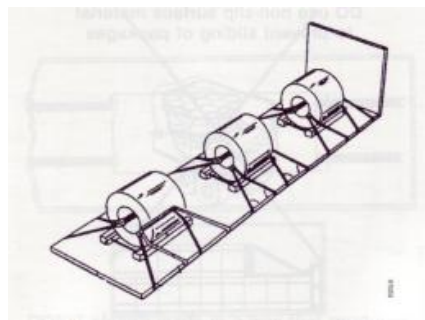

- .14 Never smoke, eat or drink during packing or unpacking.
- .15

2.2.3 Handling and transport

- .1 Never load a total mass above the permitted payload limits of the CTU, i.e. the combined mass of the cargo and the CTU must not exceed the CTU's maximum gross or safe working load;
- .2 Never load a total mass so that the combined mass of the road vehicle and / or CTU exceed any road regulations applicable on the transit;
- .3 Include all necessary documentation;
- .4 The party packing the CTU is responsible for affixing a seal to the CTU upon completion of the packing. It is the shipper's responsibility to ensure that the ~~Record the~~ seal number and ~~the~~ CTU identification number are correctly recorded on all shipping documents;
- .5 Always use the correct equipment for handling CTUs.

2.2.4 Unpacking

- .1 Before accepting the CTU check that the identification number on the CTU and the seal ~~serial~~ number are as shown on the transport documentation. If there is any difference check with the transport operator to confirm the reason for the change;
- .2 Check the exterior of the CTU ~~f~~or signs of infestation;
- .3 CTUs ~~are often~~may be sealed with high security bolt seals which can have very high shear strength. Always ensure that the proper equipment is used to cut or break ~~the such~~ seals and that operators are not over-reaching during the cutting process and are on a stable surface;
- .4 ~~Open~~ once the seal has been removed open the doors with care in case of the cargo moving within the CTU;
- .5 Check the interior of the CTU prior to unloading to confirm the condition of the packages and note any damages or movement;
- .6 Do record every package as it is removed noting any markings and damages.
- .7 Remove all dunnage and reuse, recycle or dispose in conformance with local regulations and requirements;
- .8 Clean the interior of the CTU to remove all traces of the cargo, ~~especially~~ including loose powders, grains and noxious materials;
- .9 Remove all dangerous goods marks from the exterior of the CTU once it has been cleaned.

2.3 Other regulations and conventions

2.3.1 ~~Are there any?~~

3.0 Consequences of badly packed and secured cargo

3.1 Need for cargo securing

3.1.1 The very basic physical principal behind the forces exerted by a cargo on its environment is that a moving object, if no forces are exerted, will keep on moving in a straight line at the same speed.

3.1.2 The speed of an object can be represented by an arrow; the arrow's length is proportional to how fast the object is moving. The arrows length and direction is the object's velocity. Without externally applied forces the velocity of an object remains constant, (i.e. same speed and direction).

3.1.3 To change the object's velocity, i.e. to change the length and/or direction of the arrow representing it, will require an external forces. A load platform will apply that force onto a package through the method of attachment, be it just friction or friction and securing. The package produces a reaction force, opposite to the method of attachment force, because it wants to remain at a constant velocity. Where the forces between the load platform and the package are equal then the package remains stationary on the load platform. Where the reaction force is greater than the method of attachment force, then the package will move.

3.1.4 The greater the change in velocity (e.g. for road transport: heavy braking, strong acceleration, hard cornering on roundabouts, rapidly changing lanes, etc.), the greater the forces that the cargo exerts upon its environment. For road transport these forces are mainly horizontal but for maritime transport there are both vertical and rotational forces. In these situations friction alone is seldom sufficient to stop unsecured package from sliding. It would be incorrect to assume that the weight (see section 11.2.3) will

keep the package in position. During heavy braking for instance, the reaction force exerted by the package towards the front of the vehicle can be very high and can be nearly equal the weight of the package.

3.1.5 Failure to secure packages within a CTU may result in injuries or damage to:

- the package
- the CTU
- the transport equipment
- transport or handling operatives
- the general public.
-

3.1.6 Unsecured cargo within a container can have a physical manifestation or remain hidden within.



- .1 The two pictures above are examples of unsecured cargoes where the packer considered that the cargo was properly secured, but in both cases the method of securing the cargo within the container was inadequate.
- .2 In the left hand picture the packer has attempted to restrain the cargo by placing the cargo firstly on homemade pallets and banding each with a top panel of plywood. The transverse restraint appears to be strips of plywood nailed to top and bottom. The packer had positioned the bulk of the cargo in the centre of the container to maintain the centre of gravity near to the lateral centre of the container by placing the pallets on the centre line and then placing small crates to the left and right. There appears to be no strapping to hold the pallets in place and total reliance on the nailed side strips. Vibration or rolling action over stressed the nails and they pulled out and since there was no transverse strapping the cargo packages slipped out and the load collapsed.
- .3 In this example the cargo presented little risk to those involved in the supply chain, although a potentially unstable container could increase the risk of a road incident during a sudden manoeuvre.
- .4 In the right hand picture a 40ft container loaded with 15 bundles of 24ft long steel tubing. The steel tubes had been banded adequately and during the journey each bundle appears to have remained intact. However, the steel tubes are far shorter than the length of the container and were, at the time of inspection, at the rear of the container. This may be due to the movement of the cargo during the trans-pacific voyage, or that the packer had placed them there as they were difficult to handle further into the container.

- .5 The container was part of a consignment of 25 containers carrying steel tubes. The container shown in the picture had suffered some damage due to the very eccentric load and was opened under customs supervision. Before the consignment was permitted to continue its journey, the terminal repacked the containers with proper bracing.
- .6 Unsecured cargo that is retained within the container presents an unstable / eccentric load risk that could result in handling and transport incidents mentioned in the roll over and loose cargo sections. The other consequence of unsecured cargo is the risk of it breaking through the container during transport.

3.1.7 One of the major causes of damage to CTU is the results of the vessel passing through a storm and being subject to extreme rolling (vessel can roll to 30 degrees or even further) and pitching and slamming into waves. Such extremes of angle and sudden acceleration will severely stress the container, its securing devices holding it to the vessel and the cargo within the container.

3.1.8 It does need severe weather to affect the contents of a container, on an average voyage from Hamburg to Oakland, a passage of 26 days, of which 24 are at sea, a container can experience 180,000 movements varying in severity from mild to strong. Inadequate securing methods will result in the cargo becoming loose causing potential damage to the cargo itself and / or the container. A container which undertook a similar voyage carrying electrical generators was found to be severely damaged when adjacent containers were removed. It was found that the consignor had failed to provide sufficient and adequate securing to ensure that the cargo remained safe.



3.1.9 Two wagons forming part of a freight train in the United Kingdom became derailed. During the derailment, which took place at just under 15 mph (24 km/h), all wheels of the seventh and eighth wagons from the locomotive left the rails. No one was injured in this accident.²



3.2 One of the casual factors found was that the 20ft container load was likely to have been offset to the left. The picture also shows that the strapping securing the cargo within the container has broken despite the container not falling from the wagon. The accident

² Rail Accident Report 16/2008 - Derailment at Duddleston Junction, Birmingham 10 August 2007, Rail Accident Investigation Board United Kingdom, July 2008

report states “It is likely that the banding broke and the load lozenged forward during the derailment. Given that this container remained upright on its spigots, it is likely that the centre line of the load was to the left of the centre line of the container at the time of derailment. This is supported by no obvious right to left slide marks being seen on the container floor. Estimates from photographs suggest the offset to be between 0.25 and 0.4 m.”

3.3 Mass declaration

3.3.1 ~~Overloaded or misdeclared~~ ~~The problem of miss-declared CTU weights present serious stability and safety issues, and can never be accepted. Ultimately, it is the shipper’s responsibility to ensure that this does not happen. CTUs should be properly addressed at the initial phase of packing the unit.~~ Packing of units, either at the manufacturing or producing premises, consolidation depots, or consignor’s warehouse, should be under the supervision of trained operatives who are provided with adequate information on the cargo to be packed or who possess sufficient authority to control the operation to prevent overloading and misdeclared weights.

3.3.2 ~~The shipper is responsible for ensuring that~~ ~~Consignors and packers are required to declare that the~~ actual gross mass of the CTU is in accordance with the gross mass stated on the shipping documentation ~~is correct; does not exceed the CTU’s maximum allowed gross or safe working mass; and~~ ~~and that it~~ complies with any weight restrictions. These responsibilities entail that :

- .1 The actual gross mass of the CTU ~~must, upon completion of the loading and securing of the cargo in the CTU,~~ be confirmed-verified by weighing the CTU, using a scale or weighing equipment that comply with local regulations and, further, be documented by a ~~be~~ certified weight ~~certificate~~ ticket (which can be in electronic form);
- .2 The actual gross mass of the CTU ~~must~~ not exceed the CTU’s rated maximum gross mass;
- .3 The actual gross mass must not exceed the weight restrictions on all roads, including bridges, and railways for the entire journey.

3.3.3 Occupational safety hazards caused by overloaded or misdeclared CTUs in a multi-modal transport chain include hazards:

- .1 to ship- and shore-side handlers in the event of structural failure of the unit;
- .2 to unit handlers and plant operators, particularly lift truck drivers whose vehicles may be damaged or may become unstable;
- .3 of accidents to road and rail vehicles when the overloaded container exceeds the maximum permissible weight of the vehicles. The hazards are aggravated by the fact that the road vehicle driver is often not aware that his vehicle is overloaded and does not adjust his driving habits accordingly. A further hazard can arise from the special conditions in intermodal road/rail transport in Europe, as rail-car design does not provide for a large overweight safety margin.

3.3.4 The principal hazard is of accidents involving loading or unloading a CTU on or off a ship or vehicle and container-handling equipment in the terminal area, especially when units are to be stacked pending shipment or dispatch to consignees.

3.3.5 Most cranes can be expected to have weight limit controls but, as these are designed to prevent overstressing of the crane, they will not necessarily assist in the detection of overweight CTUs.

3.3.6 When a miss-declared or overloaded CTU is offloaded from a ship or vehicle, its condition may only be discovered upon being removed for stacking in the terminal area and the handling equipment being found to have inadequate lifting capacity. Handling equipment, in some ports, may not be available for handling heavy units.

3.3.7 To prevent these hazards, the terminal should at the first entry gate at the export yard, or while the CTU is in the terminal and before it goes on a ship or vehicle, verify that weighing has occurred before entry as documented by a certified weight ticket or, if no such prior weighing can be documented, verify the actual gross mass of the CTU by use of a weighbridge or weight gauge/load indicator on yard equipment. The verified actual gross mass of the CTU should, using existing communication systems, be shared with the operator of the ship or vehicle sufficiently in advance of commencement of the stowage of CTUs for it to be used in the final stowage plan.

[COMMENT: We are aware that Germany has proposed alternative language regarding verification of CTU weights for inclusion in Chapter 12 (paragraphs 12.3.1 and 12.3.2). While we do not object to repeating the importance of verifying CTU weights in that Chapter, we strongly believe that this issue should be properly addressed already in the beginning of the COP. Furthermore, we cannot agree to the specific language proposed by Germany for two primary reasons: It introduces the packer as responsible for establishing (estimating) the weight which conflicts with the clear assignment of shipper responsibilities in SOLAS Regulation VI/2. The proposed language also suggests that an estimate of the actual gross mass might be sufficient. However, an estimate would not adequately and appropriately address recognized safety issues caused by misdeclared CTUs or ensure that the actual gross mass can be used e.g. in vessel stowage plans. Only verification of the actual gross mass would do this. In short, the German proposed language would not, we believe, address the issue effectively, would not improve status quo, and could make things worse. Finally, the above suggested amendments are consistent with existing Best Practices as set forth, e.g. in the joint ICS/WSC 2008 publication "Safe Transport of Containers By Sea: Guidelines on Best Practices", and the FTA 2011 publication "Working with containers. An FTA best practice guide".]

3.4 Concentrated loads

3.4.1 The maximum payload of a container is calculated by subtracting the tare from the maximum gross mass shown on the safety approval plate.

3.4.2 When a heavy indivisible load is to be shipped in a container, due regard should be given to the localised weight bearing capabilities of the unit. If necessary, the weight should be spread over a larger area than the actual bearing surface of the load, for example by use of properly secured baulks of timber.³

3.4.3 This also applies to consignments of dense materials that can be easily stacked such as sheet or plate steel. Containers are built to carry the payload evenly distributed across the floor, so a concentrated load approaching the maximum payload of the container and positioned so that the centre of gravity is above the centre of the container will increase the risk of failure.

3.4.4 A packer may position a heavy load adjacent to one side or end wall in the belief that the wall panel will restrain the cargo and that the floor will be stronger at the intersection of the floor and wall assemblies. Container design is such that the load needs to be evenly distributed over the entire floor and that the mass of the cargo supported on both sides by the combination of the bottom rails and the side panels.

³ IMO /ILO / UN ECE Guidelines for Packing Cargo Transport Units (CTUs), 2007 Paragraph 3.1.6

Additionally the side walls are designed to withstand forces equivalent to 60 per cent of the maximum payload evenly spread over the entire side wall. A concentrated load placed against a portion of the entire side wall may, during handling or transport movement, exert a force that is greater than the designed loads. Where the load is positioned against a side wall it can increase the instability of the container on the vehicle which could result in a roll over.

- 3.4.5 Some cargoes, such as steel wire drums can be very heavy, but easy to load and packers are more concerned with preventing the drums from rolling than the load on the load “footprint”. The footprint is the area through which the weight of the cargo is transferred to the container floor. Solid stone spheres and steel cable drums with solid rims are two examples of cargoes known to have caused serious damage to the dry freight container during carriage.
- 3.4.6 Correctly positioned concentrated loads which are secured to keep the centre of gravity at, or as close to, the centre of the container should present no additional risk of an accident occurring. However it should be remembered that a concentrated load does place extraordinary forces on the container structure during handling, and should an incident occur then those forces and the potential momentum of the load may cause structural failure and increase the severity of the accident.
- 3.5 These examples demonstrate the severe risk that unsecured cargoes can present to those involved in the supply chain and the general public.
- 4.0 General transport conditions
- 4.1 All modes
- 4.1.1 Within the supply chain there are a number of different stresses that come to play on the cargo, some of which the packer can influence during the packing operation, while others the packer must take account of when packing and securing the cargo. These stresses can be broken down into two groupings, mechanical stresses and climatic stresses.
- 4.1.2 Within the supply chain cargo transport units and their cargo are subjected to three basic operations:
- .1 Storage
 - .2 Handling
 - .3 Transport
- 4.1.3 Packing and securing of cargo into/onto a CTU should be carried out with this in mind. It should never be assumed that the weather will be calm and the sea smooth or that securing methods used for land transport will always be adequate at sea.
- 4.1.4 For all open type CTUs (sheeted CTUs, flatracks, and platforms) the effect of wind on the cargo must always be considered. The wind generated by a road vehicle travelling at 60 mph will be very similar to that generated by a train travelling at the same speed, or a container on deck in a storm.
- 4.2 Changes in air pressure can also be very similar, two road vehicles or rail wagons passing each other or a train passing through a tunnel are likely to generate areas of low pressure which can tear coverings off CTUs and packages.
- 4.3 During longer voyages, climatic conditions (temperature, humidity, etc.) are likely to vary considerably. These may affect the internal conditions in a CTU which may give rise to condensation (sweating) on cargo or internal surfaces. Where cargo is liable to damage from condensation, expert advice should be sought.

4.4 The following table⁴ provides an example of the accelerations in g's which could arise during transport operations; however, national legislation or recommendations may require the use of other values.

Mode of transport	Forwards	Backwards	Sideways
ROAD	1.0g	0.5g	0.5g
RAILWAY Wagons subject to shunting ⁵	4.0g	4.0g	0.5g (a)
Combined transport ⁶	1.0g	1.0g	0.5g (a)
SEA			
Baltic Sea	0.3g (b)	0.3g (b)	0.5g
North Sea	0.4g (d)	0.4g (d)	0.7g
Unrestricted	0.4g (d)	0.4g (d)	0.8g

This section is being researched through the National Oceanography Centre, UK

1g = 9.81 m/s²

4.5 The above values should be combined with static gravity force of 1.0g acting downwards and a dynamic variation of:

- .1 ±0.3g
- .2 ±0.5g
- .3 ±0.7g
- .4 ±0.8g

4.6 Road

4.6.1 Road transport operations may generate short-term longitudinal forces upon the cargo and the CTU. They may also cause vibrations that may vary considerably due to different suspension systems, different road surface conditions and different driving habits.



4.6.2

4.7 Rail.

4.7.1 Rail transport, in addition to subjecting cargo to vibrations (16 Hz), may also lead to

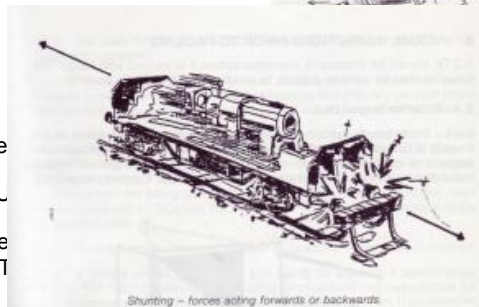

⁴ References

- Swedish, Finnish and Norwegian national road regulations
- Code of Practice - Safety of Loads on Vehicles, L
- UIC prescription - Regolamento Internazionale national regulations on securing of cargo in CT
- The Safety of Passenger Ro-Ro Vessels - Results of the North West European Research and Development Project.
- IMO Code of Safe Practice for Cargo Stowage and Securing (CSS Code).

⁵ The use of specifically equipped rolling stock is advisable (e.g. long shock absorbers, instructions for shunting restrictions).

⁶ Combined transport means wagons with containers, swap-bodies, semi-trailers and trucks, and "block trains" (UIC and RIV).

shocks as a result of shunting operations. Many railways have organised their operations in such a way as to avoid shunting of railway wagons incurring high forces (e.g. by operating dedicated block trains) or by moving CTUs on wagons with high-performance shock absorbers that are normally able to reduce shunting shock forces. It may be advisable to ensure that such operational features have been established for the rail journey.

4.8 Maritime

4.8.1 Inland river and waterway transport is generally smooth. It will not normally exert any forces higher than those of road transport on the cargo and the CTU. Diesel engines of inland river and waterway vessels may create some low frequency vibrations which under normal conditions should not give reason for any concern.

4.8.2 Container movements by terminal tractors may be subject to differing forces as terminal trailers are not equipped with suspension. Additionally, ramps can be very steep, causing badly stowed cargo inside CTUs to be thrown forward or backward.

4.8.3 Considerable forces may also be exerted on CTUs and their cargoes during terminal transfer. Especially in sea-ports, containers are transferred by shore-side gantry cranes that lift and lower containers, applying considerable acceleration forces and creating pressure on the packages in containers. Lift trucks and straddle carriers may take containers, lift them, tip them and move them across the terminal ground.

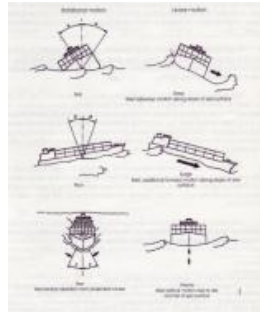
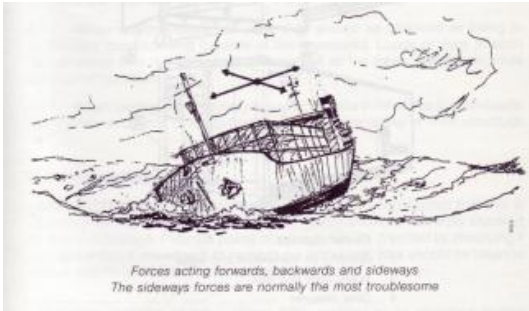

5.0 CTU properties

5.1 Containers

5.1.1 Containers generally refer to ISO series 1 container, which are a standardised design based on an 8ft width and 10ft module length, 10ft, 20ft, 30ft and 40ft. More recently to meet the requirements of the industry a 45ft length has been introduced.

5.1.2 Originally the container's height was 8ft, but this has been phased out in favour of the standard 8ft 6in high, with the higher HiCube version at 9ft 6in high.

5.1.3 The ISO series 1 containers are generally referred to by their imperial measurements, although they do have nominal metric equivalents, 3m, 6m, 9m 12m and 13.7m for the lengths and 2.5m and 2.7m high.

5.1.4 Containers are robust steel structures designed for lifting using a number of different techniques, but predominantly by the four top corner fittings. These corner fittings also permit the containers to be stacked and locked together vertically using twistlocks. **Most containers are able to have a superimposed load of 196,000kg, which relates to seven containers with an average gross mass of 28 tonnes placed above it.** While generally true, this statement needs to be qualified by language akin to that

Formatted: Highlight

included in paragraph 5.2.4 (15.2.4 in this Word document version) regarding the difference between swap bodies and containers. This is because, as Mr. Brassington will fully appreciate from his excellent work in the ISO, there are containers with reduced stacking capabilities.

5.1.5 Containers are built in five basic designs:

- .1 Closed dry container - comprising of the general purpose container, open side with door, open top with hard top and dry bulk container;
- .2 Open dry container – comprising sheeted containers (open side and open top with tarpaulins), flatracks and platform flats;
- .3 Refrigerated containers – now almost exclusively with an integrated mechanical refrigeration unit;
- .4 Tank containers – pressurised for bulk liquids, gases and dry solid;
- .5 Named containers – containers built to carry a specific cargo or product.

5.1.6 Containers are intermodal that is to say that they can be carried on road vehicles (rigid and articulated), rail wagons, inland waterway barges, coastal feeder vessels and on deep sea vessels. In general the deep sea transport will be made using a container vessel designed to carry containers above and below deck. However containers can be carried on general cargo vessels, below decks in open holds, so long as they are properly secured, or on the hatch covers on deck.

5.1.7 Containers are generally packed at a single location. While generally true, perhaps up to some 10% containers in international transport may be co-loaded, meaning that the container may be “stuffed” at several locations, making it especially difficult to arrange for a container packing plan and its compliance. and the doors sealed. Yes, they should be, but may not always be. And the correct recording of the seal number in the shipping documents should also be an industry best practice, but does not always occur. It must also be clarified that the sealing is to be done by the party stuffing the container immediately upon completion of the stuffing and cargo securing process. It is then transported to its destination without opening the doors. Expect when Customs, which often is the case in certain export countries, pops the seal and opens the doors to check the cargo. This may result in discrepancies between the number of the seal originally affixed to the container, and recorded in the shipping documents, and the seal which is on the container when the consignee takes custody of the container. It should also be a best practice for Customs to affix a new seal of at least the same category as the one that was popped, and to record the new seal number in the shipping documents. This means:

- .1 there is minimal risk of theft, so long as the containers is sealed correctly;
- .2 that since there is no need to repack on route, there should be no damage to the cargo if the packages are secured effectively;
- .3 sensitive cargoes carried in refrigerated containers can remain in a temperature controlled environment for the duration of the journey.

5.1.8 See Appendix 3 for more detailed information on container types.

5.2 Swap bodies

5.2.1 Swap bodies refer to a series of containers used within Europe, similar in design to the container, but with minor, but significant, differences. It gained its name due to the original designs where a vehicles body could be easily removed from the vehicle's chassis and placed on another.

Formatted: Highlight

Formatted: Highlight

Formatted: Highlight

- 5.2.2 Unlike the container, the original design for the swap body did not require it to be top lifted, relying on versions that could be stood on legs, or lifted using grapple arms that lifted the unit by the base frame.
- 5.2.3 Many swap bodies are still built without top lifting or stacking capabilities generally used for road and rail journeys and not used for maritime transport.
- 5.2.4 Swap bodies with top corner fittings and capable of stacking are generally far weaker than the container equivalent, typically capable of stacking one or two loaded containers above it only. As some swap bodies appear almost identical to containers, it is important that the packer and transport operators appreciate the differences and take account of the weaker designs when stacking.
- 5.2.5 The European swap body comes in three basic length configurations:
- .1 Short length – 7.15m, 7.45m and 7.85m length, generally fitted with demountable legs and “corner fittings” set on the 20ft container grid centrally;
 - .2 Mid length – 30ft, generally for dry bulk cargoes;
 - .3 Long length - 13.6m long and more recently 45ft long.
- 5.2.6 The swap body is generally 2.5m or 2.55m wide, although refrigerated swap bodies can be 2.6m wide.
- 5.2.7 There are also 2.5m wide 40ft swap bodies that are identical to 40ft containers apart from the width and the reduced stacking capabilities. Care must be taken not to confuse the two designs.
- 5.3 Domestic and regional containers
- 5.3.1 There are a number of regional variations to the (intermodal) container, designed to meet the particular requirements of a region or country and which complies with local laws and regulations.
- 5.3.2 In the USA, a regional container is generally 8ft 6in wide and includes 48ft, 53ft and longer lengths.
- 5.3.3 In Australia, there are regional variations to length and height.
- 5.3.4 In China and Japan there are variations to length which can be carried on their rail system.
- 5.4 Road vehicles
- 5.4.1 Road vehicles come in two basic forms:
- .1 Rigid designs;
 - .2 Tractor and trailer designs.
- 5.4.2 Within each group there are a plethora of different designs which are broadly similar to the groups described containers (see 5.1.5).
- 5.4.3 Tractor and trailer combinations come in a number of variants:
- .1 Articulated – a tractor unit with a semi trailer / chassis, where the front end of the trailer is supported on the rear of the tractor unit;
 - .2 Full trailer – a tractor unit or rigid vehicle can tow a trailer with a steerable front axle and one or more fixed rear axles;
 - .3 Close coupled trailer – generally a rigid vehicle can tow a trailer with two or more central axles.

5.4.4 Road vehicle bodies are generally lighter in construction than containers or swap bodies, and the tare mass of the trailer is often considerably lower than a container and trailer combination.

5.4.5 Rigid box trailers and vehicles will often have a number of horizontal lashing bars, which enables the packer to secure packages at various heights and at more frequently along the length.

5.4.6 While road vehicles are generally transported on roads, there is increasing demand for trailers and road vehicles to be transported over longer distances on rail wagons, often referred to as TOFC (trailer on flat car). These rail wagons can be simple flatbed wagons or specialist spine wagons designed to carry the trailer at a lower height and using a spine that fits between the road wheels.

5.5 Rail wagons

5.5.1 Rail wagons come in a number of different designs which can be categorised into the following groups:

- .1 Box cars / wagons;
- .2 Open cars / wagons;
- .3 Tank cars / wagons;
- .4 Container cars / wagons;
- .5 Vehicle carriers;
- .6 Specialist cars / wagons.

5.5.2 With regard to packing CTUs the majority of the rail wagons are used to transport another item of transport equipment.

5.5.3 The most likely designs for be packed will be the closed box car or the open flat.

6.0 Responsibilities and Information chains

6.1 Chain of Responsibility

6.1.1 For the consignment to reach its destination without damage or loss, there is a responsibility of all parties in the supply chain to fulfil their part with care and attention.

6.1.2 The packer has the most important role by ensuring that packages are secured within the CTU so that there is minimal risk of the packages moving or collapsing.

6.1.3 The packer must also ensure that the cargo is identified correctly and that any risk to persons involved in the supply chain or who come in contact with the CTU is minimised. This includes marking the CTU with any and all hazard marks required by codes such as the IMDG code. This should include any hazardous gases used in the preparation or production of a cargo that may emanate from the cargo in transit. Ultimately, however, the shipper is responsible for ensuring that only CTUs are offered for transport that are safely and securely packed and marked and placarded in accordance with current rules and regulations, and have a verified actual weight as documented by a certified weight ticket.

6.1.4 After that the road and rail transporters have a responsibility to move the CTU in such a manner as to avoid that ~~there are~~ no exceptional stresses are placed on the CTU or the cargo. This means that the driver of road vehicles must be aware of the idiosyncrasies of the cargo and drive accordingly, for example:

- .1 Bulk liquids carried in flexitanks within general purpose containers;

.2 Hanging cargo such as sides of beef carried in refrigerated vehicles.

6.1.5 Operators involved in the handling (lifting and carrying) of CTUs should ~~also~~ ensure that the CTU is not subjected to abnormal handling stresses when lifting and lowering CTUs (containers) into and from ships or vehicles. Particular attention should be given to landing containers in cells and on the deck so that sudden deceleration does not occur. The export yard should verify that weighing of the CTU has occurred before entry and, where no such prior weighing can be documented, verify the actual gross mass of the CTU.

6.1.6 Ship operators are ~~also~~ responsible for securing the CTU properly within or on their vessel as to prevent as far as is practicable, throughout the voyage, damage or hazard to the ship and the persons on board, and loss of cargo overboard [COMMENT: Amendment reflects current SOLAS VI/Regulation 5.1] ,—The CTU should be ~~and placing~~ placed in a location that is appropriate to the cargo's verified actual declared mass as communicated by the terminal and reflected in the final vessel stow plan , and the CTU type. The ship operator should also as well as ensuring ensure that the proper segregation of sensitive or dangerous cargoes are adequate.

6.1.7 Those involved in unpacking the CTU also have a responsibility to unpack the CTU with due care to the cargo and those involved in the operation. This extends to ensuring that all packages are identified and their condition noted.

6.1.8 All persons involved in the movement of CTUs also have a responsibility to ensure that the CTU is not infested with insects or other animals, or that the CTU is not carrying illegal goods or immigrants, contraband or undeclared or miss-declared cargoes. This needs to be re-worded, and possibly broken into several paragraphs. First, there is the issue of infestation – the operator of the CTU is responsible for delivering a clean CTU free of infestation, but it is then the responsibility of the person stuffing the CTU that no infestation occurs while the CTU is being loaded and await transport. Next, it is the responsibility of the person stuffing the CTU, and ultimately that of the shipper, that only legitimate cargo shipments are loaded into the CTU and that the CTU, upon completion of the loading, is sealed and the seal number is recorded in the shipping documents. The shipper is also responsible for providing in the shipping documentation accurate and complete cargo descriptions and other pertinent information to the transport operator, who – in turn – is responsible for accurately and timely to include the information in the shipping documentation in the bill of lading, airway bill etc. and also in notification and reporting formalities required by authorities. Contrary to what the current text suggests, a transport operator can never be responsible for the content of a sealed CTU.

Formatted: Highlight

Formatted: Not Highlight

Formatted: Highlight

6.2 Chain of Information

6.2.1 To ensure that the cargo is transported from originator to destination safely and securely, it is essential that those involved in the CTUs movements fully comply with the proper flow of information.

6.2.2 This includes the responsibility of the packer to identify all packages packed into a CTU and for the shipper to include this and other relevant information such as the CTU and seal numbers ~~it~~ in ~~all the shipping appropriate~~ documentation.

6.2.3 Additionally it will include ~~a the~~ responsibility of the shipper to verify the actual for a declaration to be made on the actual mass of cargo carried within the CTU as documented in a certified weight ticket, and as well as any hazards that may be present for all or some of the journey.

6.2.4 ~~The shipper is also responsible that Parties involved with transport should also ensure that~~ documentation and information is provided in adequate time and using terms that are internationally accepted. This includes:

- .1 The use of proper shipping names;
- .2 The correct orientation terms for packed items;
- .3 A general description that accurately describes the cargo.

~~6.2.5 The transport operator is responsible for accurately and timely including the information in the shipping documentation in the bill of lading, airway bill etc. and also in notification and reporting formalities required by authorities.~~

~~[COMMENT: The shipper, not the transport operator, is responsible for providing e.g. accurate cargo description etc. The transport operator cannot be responsible for verifying the accuracy of e.g. the cargo description for shipments in a sealed CTU].~~

Formatted: Outline numbered +
Level: 3 + Numbering Style: 1, 2, 3, ...
+ Start at: 1 + Alignment: Left +
Aligned at: 0 cm + Tab after: 2.5 cm
+ Indent at: 1.5 cm

Formatted: Font: 12 pt

Formatted: Font: 12 pt, Not Bold

Formatted: Font: 12 pt

Formatted: Font: Not Bold

Code of Practice for Packing of Cargo Transport Units (CTUs) (CTU Code)

7.0 Chain of Responsibilities

7.1 **Consignor** / Packer

Formatted: Highlight

7.1.1 Before a CTU is packed, it should be ensured that the personnel responsible for the packing are fully informed about all the risks and dangers involved. As a minimum requirement some sketches showing the basic rules of CTU packing should be available. The present Guidelines should also be readily available. If necessary, the **shipper** and the packing personnel should consult each other regarding any special feature of the cargo to be packed into the units. In particular, information on possible dangerous cargoes should be considered very carefully. Consideration should also be given to the provision of appropriate training for personnel involved in packing CTUs. [COMMENT: There needs to be consistency throughout regarding terms used. We prefer to consistently use the term "shipper" instead of "consignor" which is also the term used e.g. in SOLAS]

Formatted: Highlight

7.1.2 When packing a CTU, the **shipper** and persons responsible for packing should bear in mind that any failure to pack and secure the cargo correctly may result in additional costs that they will have to bear. If, for example in railway transport, a unit is found not to be properly packed and secured, the rail-car may be marshalled out of the train into a siding and the transport can only be continued once the cargo has been properly secured. The shipper may have to pay for this work, especially for the repacking and resecuring operation, as well as for the additional time during which the rail-car has been used. In addition, he may be held responsible for any delay of the transport operation. [COMMENT: While not disagreeing, the primary concern must always be the safety of the conveyance and its crew and shore personnel handling CTUs]

Formatted: Highlight

7.2 Consolidator / Packer

7.3 Freight Forwarder

7.4 Road Carrier

7.5 Rail Carrier

7.6 Terminal and stevedore

7.7 Maritime Carrier

7.8 Consignee

8.0 Chain of Information

8.1 Information necessary for safe

8.2 Information flow paths

8.3 CTU information circulation

8.4 CTU information timing

9.0 Suitability of CTU

9.1 Cargo to be carried

9.2 Transport route

9.3 Security

Text for these sections still in preparation

9.4 Transport Modes

9.5 Handling

10.0 Before packing CTUs

10.1 Before packing a CTU, careful consideration should be given as to how the unit will be presented during the packing operation. The same applies for unpacking. The CTU may be presented for packing or unpacking as follows:

- loaded on a semi-trailer chassis together with a truck;
- loaded on a semi-trailer chassis, but without a truck;
- loaded on a rigid truck or chassis;
- standing on the ground;
- standing on its supporting legs (in case of class C swap-bodies);
- loaded on a rail-car;
- loaded on an inland barge; or
- loaded on a seagoing vessel.

10.2 Any of these configurations is possible. The actual packing or unpacking situation often depends on site and facility considerations. However, whenever the CTU is presented on a chassis or on supporting legs, special care should be taken in planning the packing or unpacking operation.

10.3 CTU Arrival

10.3.1 The type of CTU arriving at a packing facility will dictate:

- .1 the process of confirming that it is fit for use;
- .2 the CTU's positioning to suit the packing operation and timing;
- .3 the planning of the cargo packing.

10.3.2 The CTU provider will advise of the estimated time of arrival and departure. The type of CTU may influence these timings:

- .1 Rigid road vehicles will come with a driver and it would be expected that the time to pack the vehicle will be dictated by any time restrictions that local regulations may impose.
- .2 Detachable CTUs, such as trailers and rail wagons can be left at the packer's facility and the tractor unit / motor unit permitted to depart if the packing procedure is extended.
- .3 Class C Swap bodies fitted with legs can be unloaded onto their legs and the tractor unit / engine unit plus trailer (if present) can be driven away.
- .4 Containers and Class A and B swap bodies can remain on the trailer or be unloaded and placed on the ground.
- .5 CTUs remaining on trailers may be left for a period of time, however, the CTU provider may charge demurrage if the period is overlong.

10.3.3 If the consignment requires more than one CTU then it is important to plan what packages go within each unit and how each CTU is managed:

- .1 Multiple units can be delivered all at once and the packer can manage positioning of each unit to suit the facility available.
- .2 Multiple units can be delivered sequentially so that the container operator delivers an empty unit and picks up a fully packed one.

- .3 In both cases planning what packages goes into each unit will be important. Demand at the destination may require particular packages to be packed in each CTU. However such demand pull can have an adverse effect on the load distribution and volume utilisation. It is therefore important that a complete plan is generated for all packages and CTUs prior to the start of packing the first CTU.

10.4 CTU Checks

A CTU should be thoroughly checked before it is packed with cargo. The following may be used as a guide to inspecting a unit before packing.

10.4.1 Exterior checks

- .1 Check that the container serial number and size / type code are the same as those provided by the operator.



- .2 Checks to a road vehicle, a rail wagon or a container differ by type. However the checks described below may be used for all types, but where it refers to a particular CTU type, then those types will be identified.
- .3 The structural strength of a CTU (container) depends to a great extent on the integrity of its main framework comprising the corner posts, corner fittings, main longitudinal and the top and bottom end transverse members which form the end frame. Please refer to section 10.4.4 for further information on structurally sensitive components.
- .4 Road vehicles and rail wagons have less stringent structural requirements, however the following items should be considered for all transport modes.

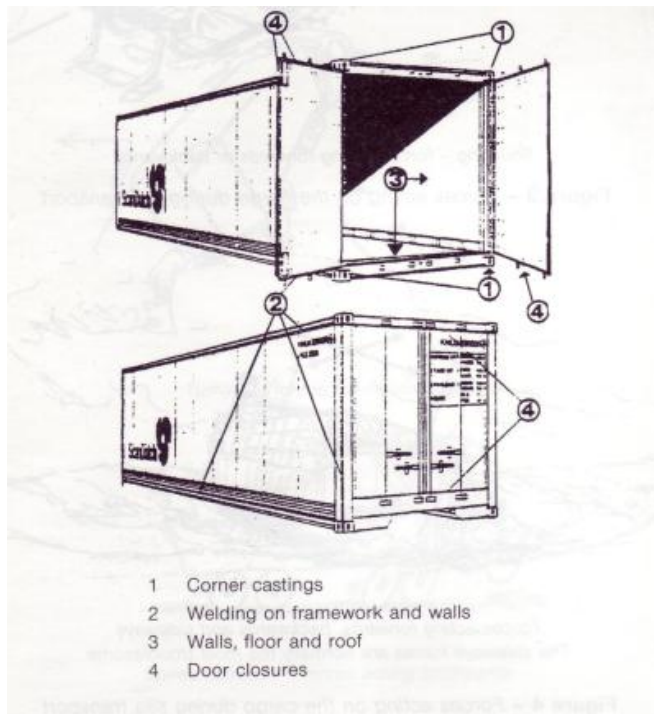

Figure 5 – checking a container

- .5 The walls and roof of a CTU should be in good condition, and not significantly distorted. CTUs where there is distortion to the sides and walls may adversely affect packing, but will not normally affect the structural integrity of the CTU.
- .6 The doors of a CTU should work properly and be capable of being securely locked and sealed in the closed position (see section 13.3.6), and properly secured in the open position. Door gaskets and weather strips should be in good condition.
- .7 A container on international voyages should be affixed with a current International Convention for Safe Containers (CSC)⁷ Safety Approval Plate (see section 10.4.3). Swap-bodies and road trailers destined for transport by rail may also require marking as per EN 10344.⁸ The operational marking provides information for codification and for approval of the swap body or semi-trailer for transport within the European railway network.. Such swap-bodies need not be affixed with a CSC plate, but many of them will have one in addition to the yellow code plate.

⁷ International Convention for Safe Containers (CSC), published by the International Maritime Organization (IMO).

⁸ EN 13044 Intermodal Loading Units, Part 2: Markings of swap bodies related to rail operation, and Part 3: Marking of semi-trailers related to rail operation, 2011.



- .8 Irrelevant labels, placards, marks or signs should be removed or masked. [COMMENT: We do not disagree, but care must be taken to not “mask” container number and other information required by law to be on the CTU, e.g. tare weight and size/type codes]
- .9 Road vehicles that are likely to be carried on rail wagons or on RO-RO vessels should be provided with points for securing them (refer to EN 29367-1 / ISO 9367-1: Lashing and securing arrangements on road vehicles for sea transportation on Ro/Ro ships - General requirements - Part 1: Commercial vehicles and combinations of vehicles, semi-trailers excluded, and to EN 29367-2 / ISO 9367-2: Lashing and securing arrangements on road vehicles for sea transportation on Ro/Ro ships - General requirements - Part 2: Semi-trailers).
- .10 There should be equal numbers of lashing points on both sides of the vehicle and each point should be intact and free from serious corrosion or damage.
- .11 For sheeted vehicles or containers the side, top or all round covers should be checked as being in satisfactory condition and capable of being secured. Loops or eyes in such canvas which take the TIR fastening ropes, as well as the ropes themselves, must be in good condition. All lashing strap ratchet tighteners must be able to be engaged and operate correctly.
- .12 Free standing swap-bodies or swap bodies and containers mounted on trailers where the units is only supported at the corner fittings rely on the strength of the floor and under structure when loading. It is therefore important to check that the cross members look in good order,

Formatted: Highlight

10.4.2 Interior checks

- .1 Before entering a CTU open the doors wide and do not enter the CTU for at least five minutes to allow the internal atmosphere to regularise with ambient.
- .2 A CTU should be clean, dry and free of residue and / or persistent odours from previous cargo.
- .3 A CTU should be free from major damage, with no broken flooring or protrusions such as nails, bolts, special fittings, etc. which could cause injury to persons or damage to the cargo.
- .4 Check for stains and liquids on flooring and side walls. There are a number of different materials and surface finishes used for flooring in CTUs. Seal surfaces generally can be cleaned with absorbent materials. For unseal floors, any stain that can be transferred by wiping a gloved hand over it, should not be used and a replace CTU requested.
- .5 A CTU should be weatherproof unless it is so constructed that this is obviously not feasible. Patches or repairs to solid walls should be carefully checked for possible leakage by look for rusty streaks below patches. Repairs to side and roof sheets

should have a fully stitched patch covering all of the hole with a substantial overlap.

- .6 Potential points of leakage may be detected by observing if any light enters a closed unit. At least two persons are need for this check, the person who remains outside, must be fully aware of the process of shutting and opening the doors and be capable of doing so. To complete the check one person should enter the container and the doors closed and the locking gear engaged fully. Checks should be made all round the closed door gaskets and then the sides and roof. Holes or gaps will be evident by the light entering the CTU. In carrying out this check, care should be taken to ensure that no person becomes locked inside a unit.

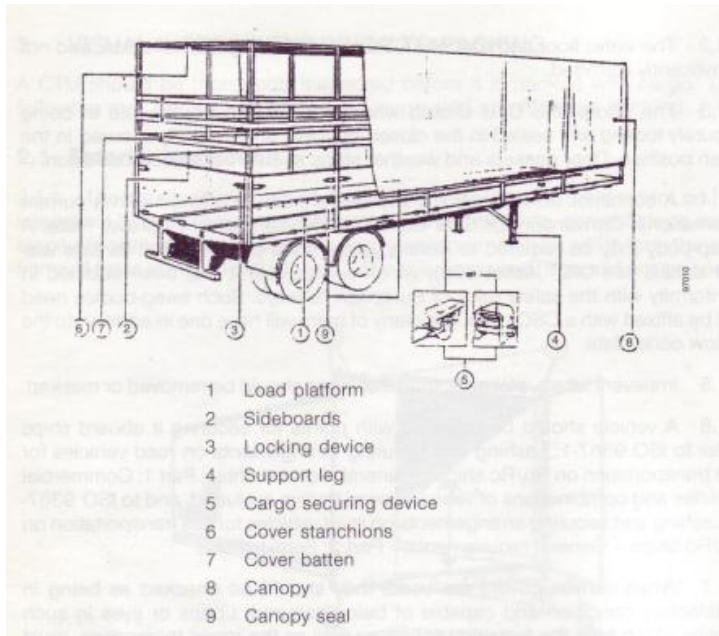

Figure 6 – Checking a semi trailer

- .7 Cargo tie-down cleats or rings, where provided, should be in good condition and well anchored. If heavy items of cargo are to be secured in a CTU, the **forwarder or shipping agent/operator of the CTU** should be contacted for information about the cleat strength and appropriate action taken.
- .8 Containers have a limited number of lashing rings or bars. 20ft containers have four attached to each of the top and bottom side rail, generally within the corrugations, 40ft will have eight. All sizes will have three of four lashing bars across the corners of the front corner posts and there may be three bars within the shoring grove at the door end.
- .9 A folding CTU with movable or removable main components should be correctly assembled. Care should be taken to ensure that removable parts not in use are packed and secured inside the unit.

10.4.3 Safety and biotic checks

- .1 Safety checks consider those features of the CTU that may place persons at risk. Biotic checks consider infestation by animals and / or insects.

- .2 Under the CSC containers are required to be thoroughly examined at least every 30 months. Every container used for international transport must have a CSC Safety Approval Plate permanently affixed to the rear of the container, usually the left hand door. On that plate or immediately beside it should be a mark that indicates that it has been inspected. A mark starting “ACEP” followed by numerals and letters indicates that the operator has a continuous examination programme, where the container is examined at major interchanges.
- .3 A container without an “ACEP” mark must have an mark, either a decal or stamped onto the safety approval plate the date of the next thorough examination. The date of the next examination should be after the expected date of arrival at the destination.
- .4 If there is no ACEP mark and the next examination date is not in the future, or is before the expected arrival time, the container should be rejected.
- .5 Any component that can be adjusted or moved, or pin that can be engaged and withdrawn should be checked to see that it can be moved easily and retained correctly. This is particular importance for folding flatracks where the end-walls are retained in the upright position by a pin or shoot bolt which should be engaged and retained from accidentally pulling out by a retaining flap.
- .6 Another major component that needs careful attention is the removable or swinging header from open top CTUs. The header is generally supported by removable pins. Checks should be made to ensure that the pins are of the correct length and freely removable at both ends. Checks should also be made for signs of cracks around the hinges.
- .7 When undertaking the exterior checks, check the under structure with a torch for any signs of inspect or wasp nests particularly on the inside of cross members.
- .8 During the interior checks, look for signs of nests or animals particularly in open section at the header over the door and at the front end.

10.4.4 Serious structural deficiencies

- .1 This section only refers to containers engaged in the carriage of international transport covered by the International Convention for Safe Containers. Regional and domestic containers may be covered by local regulations or legislation that requires the container to be maintained in line with the requirements of the CSC.
- .2 The International Convention for Safe Containers (CSC), 1972 includes information on unsafe containers and serious structurally sensitive components and the definition of serious structural deficiencies.⁹ While the recommendations are aimed at Control Officers, it is important that the responsible person at the packer’s facility undertakes structural checks that include all of the structurally sensitive components.
- .3 The structurally sensitive components are the:
 - top rail;
 - bottom rail;
 - header;
 - sill;
 - corner posts;

⁹ Revised recommendations on harmonized interpretation and implementation of the international convention for safe containrs, 1972, as amended, CSC.1 / Circ. 138, IMO, June 2010.

- corner and intermediate fittings;
- understructure; and
- locking rods.

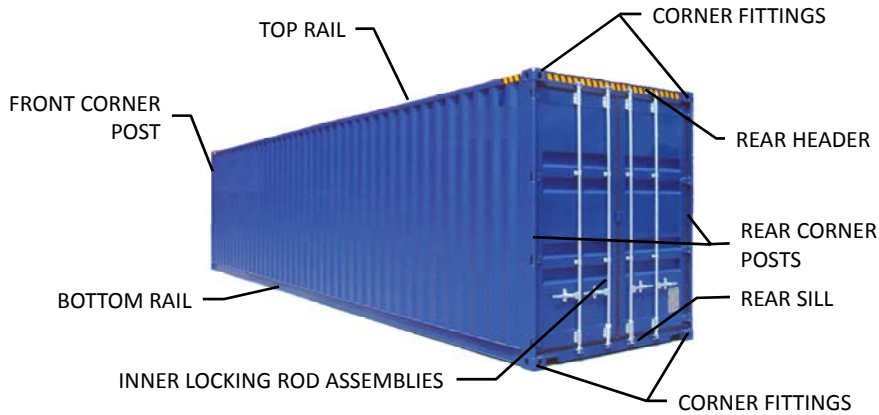

.4 The table below identifies the extent of the damages that would render a container unfit for use.

STRUCTURALLY SENSITIVE COMPONENT	SERIOUS STRUCTURAL DEFICIENCY
Top rail	Local deformation to the rail in excess of 60 mm or separation or cracks or tears in the rail material in excess of 45 mm in length. Note: On some designs of tank containers the top rail is not a structurally significant component.
Bottom rail	Local deformation perpendicular to the rail in excess of 100 mm or separation or cracks or tears in the rail's material in excess of 75 mm in length.
Header	Local deformation to the header in excess of 80 mm or cracks or tears in excess of 80 mm in length.
Sill	Local deformation to the sill in excess of 100 mm or cracks or tears in excess of 100 mm in length.
Corner posts	Local deformation to the post exceeding 50 mm or tears or cracks in excess of 50 mm in length.
Corner and intermediate fittings (Castings)	Missing corner fittings, any through cracks or tears in the fitting, any deformation of the fitting that precludes full engagement of securing or lifting fittings, any deformation of the fitting beyond 5 mm from its original plane, any aperture width greater than 66.0 mm, any aperture length greater than 127.0 mm, any reduction in thickness of the plate containing the top aperture that makes it less than 23.0 mm thick or any weld separation of adjoining components in excess of 50 mm in length.
Understructure	Two or more adjacent cross members missing or detached from the bottom rails. 20% or more of the total number of cross members missing or detached. Note: If onward transportation is permitted, it is essential that detached cross members are precluded from falling free.
Locking rods	One or more inner locking rods are non-functional. Note: Some containers are designed and approved (and so recorded on the CSC Plate) to operate with one door open or removed.

- .5 Containers that exhibit deficiencies equal to, or greater than, those described in the recommendations should not be packed and returned to the container operator. If the responsible person is uncertain about the degree of damage to any of the structurally sensitive components the packer should contact the operator for further advice.
- .6 If the responsible person is concerned about the containers delivered they should approach the container ~~supplier-operator~~ to request further assistance and guidance on its use.

10.5 Positioning CTU for packing

10.5.1 Wheeled operation

- .1 Road trailers and containers on chassis can be left at the packer's premises for a period of time without a tractor unit. When this happens, positioning the CTU is particularly important as it can be difficult the CTU once packing has started.
- .2 When a CTU is to be packed on two or more days, it is important that the CTU can be closed overnight. Firstly to protect the cargo from theft, but also to prevent nocturnal creatures entering.
- .3 CTUs that can be backed up to an enclosed loading bay, it is likely that there will be a roller shutter door which can be closed as the CTUs doors will be trapped open by the loading bay structure.
- .4 Where the CTU cannot be closed in-situ because of the loading bay structure, or where to secure the area the CTU would need moving then the packer should consider positioning the CTU so that the doors to the facility and / or the CTU can be closed and access is gained by a removable ramp.
- .5 The alternative to positioning the CTU and using a ramp is to use a tractor unit to reposition the CTU overnight or when packing has been completed. However it important to use only a proper trailer tractor unit or tug to move the trailer. Fork trucks should not be used to lift the front end and to attempt to drag the trailer.
- .6 CTUs can be packed away from a loading bay by the use of fork trucks working in the trailer yard. Open side CTUs are easy to pack with palletised packages. CTUs with doors at the rear may require a pallet truck to move packages within the unit.
- .7 A CTU to be packed should rest on level and firm ground or on a trailer or a rail-car. If a CTU is on a trailer, care should be taken to ensure the trailer cannot tip while the container is being packed, especially if a lift truck is being used. Brakes should be securely applied and the wheels chocked.

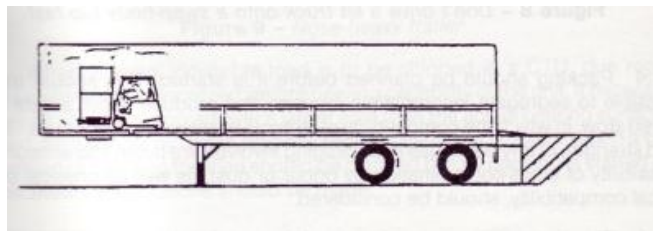

- .8 The support legs of the chassis are designed in such a way that they can carry the total permissible weight of the load or their own maximum payload. However, the

support legs are unable to bear additional forces which would arise e.g. by driving into a container of this kind with a fork-lift truck.

- .9 To counter this supports can be placed under the front of the trailer during loading. It is important that the supports themselves are safe and fulfil the task required:

- The use of such items such as pallets is **NOT** safe as there is a very great risk of the pallet collapsing at the slightest horizontal movement of the semi-trailer. During loading and unloading, the position of the loading area in relation to the horizontal plane changes, because the vehicle rides up and down on the suspension.



- Purpose made spring loaded and adjustable supports can be fitted under the front of the trailer. However it is important to monitor the trailer as the packing proceeds and the suspension and the height of the chassis changes. The supports must therefore be regularly checked and adjusted. Any continuation of work under these conditions would represent a breach of regulations.



10.5.2 Grounded operation

- .1 It is possible to unload containers from the delivery vehicle and place them within secure areas for packing. Unloading empty and loading full containers must be carried out by proper lifting equipment (see 14.2.6). Containers should never be lifted using two or more fork trucks.



- .2 When landing containers make sure that the area is clear of any debris or undulations in the ground that may damage the under-structure. Damage to the cross members or rails may result in charges being levied against the packer.
- .3 The construction of the container is such that they are fairly flexible, which means that when placed on the ground all four corners will attempt to ground themselves with the consequence that the container will twist. Whilst the container doors remain closed, the rear frame will remain reasonably square, but if the ground is not level and as soon as the doors are opened, the rear frame will distort so such an extent that it may be difficult or impossible to close the doors.
- .4 Therefore when landing a container on the ground look for signs that the container is un-level:
 - one rear corner is slightly raised off the ground;
 - the doors are out of line; or
 - the anti-racking plate is hard against one of the stops.

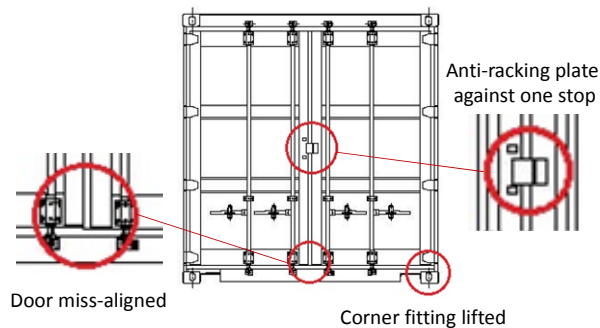

- .5 Should any of these be present it will be necessary to place shims under one or other of the rear corner fittings to level out the container doors.
- .6 The container floor is tested using a test load of 7,260 kg (16,000 lbs) with a maximum contact area of 284 cm² (or 25.56 kg/cm²). When packing a container using a counterbalance fork truck, it is important that the front axle load does not exceed this. However, when the container is placed on the ground, it is possible to exceed that limit after gaining approval of the container operator.

10.5.3 Swap Body operation

- .1 When a swap-body standing on its supporting legs is packed, particular care should be taken to ensure that the swap-body does not tip when a lift truck is used for packing. It should be checked that the supporting legs of the swap-body rest firmly on the ground and cannot shift, slump or move when forces are exerted to the swap-body during packing.
- .2

11.0 Packing cargo

11.1 Packing CTUs requires seven major stages:

- .1 Understanding stresses;
- .2 Planning the packing process;
- .3 Placing the packages into the CTU;

- .4 Securing the packages;
- .5 Closing the CTU;
- .6 Producing documentation.

Each of these six stages will be discussed in more detail in the following sections

11.2 Understanding stresses

11.2.1 Section 2.2 identifies the main bullet points of the planning process. This section elaborates on those points and provides more explanation on the planning process.

11.2.2 In any CTU forces and stresses act upon every package packed within the CTU as well as the CTU itself. In mechanical terms there are static and dynamic stresses. Each requires different attention during the packing process.

11.2.3 Weight and Mass

- .1 Weight is often used to describe mass and it is important to understand the difference between the two. Mass is a property of matter. All objects have a mass, which is not effected by the environment it is within, for example an object with a mass of 100 kg will have the same mass on the surface of the earth or the moon.
- .2 Weight on the other hand is used to denote either the mass of a body or the force of gravity acting on it. In the United Kingdom the Weights and Measures Act, it has been used in the sense of a mass.

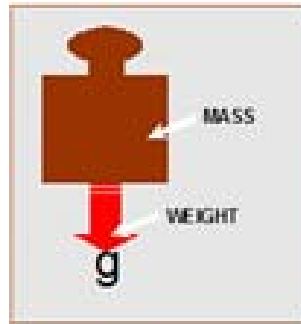

- .3 In the CGPM¹⁰ and various and technical works, it is used in the sense of a force.
- .4 In this Code the definition of weight it is a measure of the gravitation force acting on a material object at a specific location. That means that an object with a mass of 100 kg will have a weight of 100 kgf on the surface of the earth but only 17 kgf on the surface of the moon.
- .5 Changing the effect of gravity caused by the CTUs movement will change the weight. Allow the container to fall downwards with acceleration greater than 9.8 m/sec and the mass becomes weightless. Move the container upwards at a similar speed and the weight of the mass doubles.

11.2.4 Forces action on a package

- .1 When planning to pack a cargo transport unit, a number of issues need to be considered. Perhaps one of the most important aspects is accurately knowing the mass of the cargo and recognising that the forces acting on the cargo transport unit will affect that mass in different ways.
- .2 The weight of a cargo can increase and decrease as the cargo transport unit rises and falls, (say at sea). As a road vehicle turns a corner, or goes round a sharp bend, the cargo's mass will be forced outwards which may cause the vehicle to overturn.

¹⁰ Conférence Générale des Poids et Mesures or the General Conference on Weights and Measures (CGPM, never GCWM).

- .3 What causes the cargo to be forced outwards? When an object is rotated (representing a road vehicle going round a sharp bend) there is a force required to pull the object round the curve. This is shown in the diagram as force and is called centripetal force and in the road vehicle would be the engine driving the steering wheels.
- .4 Once the object is in motion and then the force pulling it towards the centre of the curve removed, inertia takes over and the object would then follow a straight line. Sometimes this is incorrectly called centrifugal force.
- .5 The force that drives objects outwards is a reaction force which the object exerts against the centripetal force.



11.2.5 Centre of Gravity

Centre of gravity (CG) refers to:

- .1 The point in or near a body at which the gravitational potential energy of the body is equal to that of a single particle of the same mass located at that point and through which the resultant of the gravitational forces on the component particles of the body acts.
- .2 In more general terms the CG is at the intersection of the balance position (lines) of each of the three section planes (plan, front and side).
- .3 While the CG is exactly over the intersection of the balance positions of the base and either the face or side planes the object will be stable. Move the CG away from that position and the object becomes unstable.
- .4 There are two major causes for the CG to move away from that base intersection point:

The object is tilted due to rolling of the transport mode deck; or
 The resultant force caused by a combination of gravity and the sideways (reaction) force

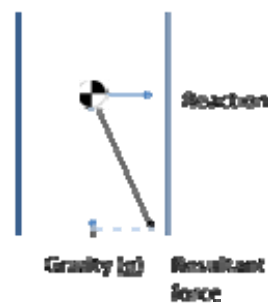
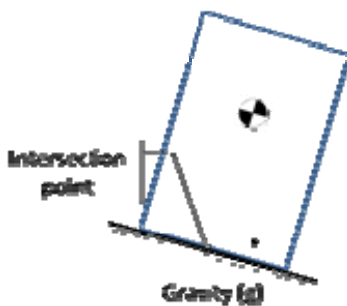

caused by a sharp turn.

- .5 The further that the CG gets from being directly above the intersection point the more unstable the object becomes.
- .6 An object will fall over when the centre of gravity or the resultant forces moves outside of the base plane.

- .7 An object with a high The higher the CG requires ais the smaller the angle of the transport mode deck or the sideways (reaction) force cause by a sharp turn for it to become unstable.

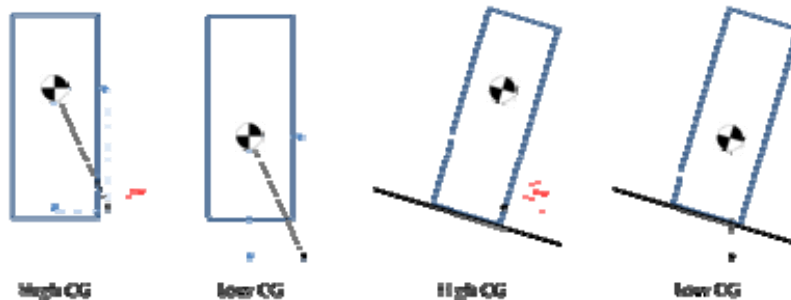

- .8 An object with a narrow The smaller the foot print requires a of the object the smaller the angle of the transport mode deck or the sideways (reaction) force cause by a sharp turn for it to become unstable.

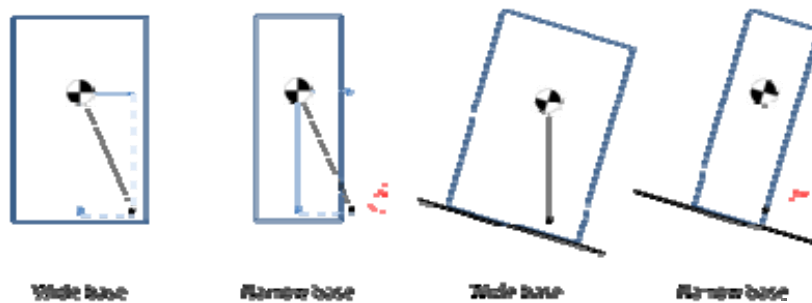

- .9 Understanding the exact position of the CG is important for stability. A CG close to one edge will result in asymmetric stability, that is to say when an object has a reaction force applied in one direction it will remain stable, whereas the same value of force in the other direction will cause the object to be unstable and the subsequent risk of the object overturning.

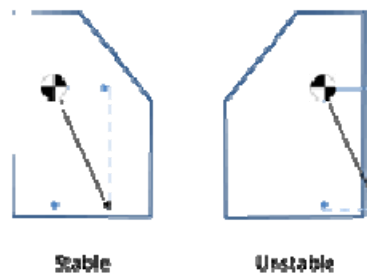

11.2.6 Static mechanical stresses

- .1 Static mechanical stresses generally causes damage due to pressure. In the supply chain, this pressure is generated by overloading the stacking strength of the lower packages.
- .2 Typically, packages are thought of as either light or heavy, so neglecting the fact that these are relative terms and when producing packing plan it is important to verify the actual mass and the packages s tacking strength.
- .3 For example as we can see with the graphic shown that as cartons are stacked within a CTU we must remember that the bottom most carton

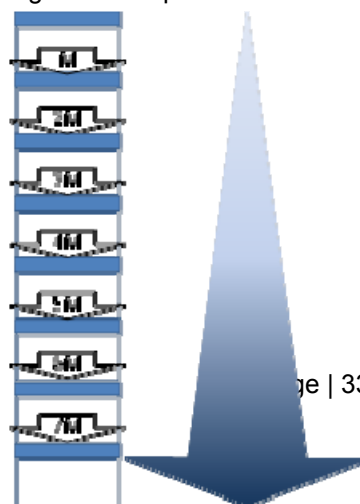

must have a stacking strength that will support all of the weight of the packages stacked above.

- .4 The same calculation should be carried out when packages are placed onto a pallet to ensure that the pallet is sufficiently strong to withstand the pressure of those packages.
- .5 Recognising that the weight of a cargo can changes affects the way that it is secured within the cargo transport unit which we will see later on within Module 3in this course.
- .6 Additionally, to keep the centre of gravity as low as possible, heavy packages should be stowed below lighter packages. But it must be remembered that if packages are placed above the heavy package then the lower packaging must be able to support those placed above.
- .7 The last consideration is the size of the package. It may be assumed that the heavy package is larger than the light package(s). However this is not always the case and consideration must be given to packing where the heavy package is smaller than the superimposed lighter package.
- .8 A larger package placed above a smaller one must stable at all times and all items must be properly secured to prevent movement

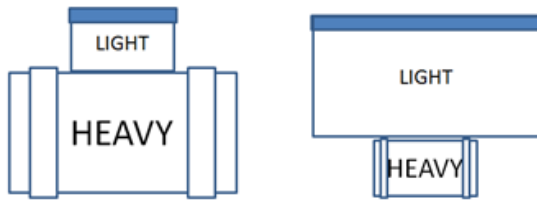

- .9 Pressure (P) is the force applied on one object by another divided by the contact area (footprint). In a static condition the pile of cartons will exert a force of M multiplied by gravity (g) on the deck and with a contact area (footprint) of A equivalent to a pressure of (M*g)/A KPa (kilopascals) (see formula right).
- .10 In the examples shown below the total mass of both stacks is 8M. However the contact area for one (stack 1) is four times the value of the other (stack 2). Using the formula to the right it can be seen that increasing the area by four results in a four fold increase in pressure (stack 1 – 2M against 8M for stack 2).Consequently stack 2 exerts four times the pressure on the deck than stack 1 does.

$$P = \frac{F}{A}$$

or

$$P = \frac{M \times g}{A}$$

Stack 1

$$P = \frac{8M \times g}{4A}$$

or

$$P = \frac{2M \times g}{A}$$

Stack 2

$$P = \frac{8M \times g}{A}$$

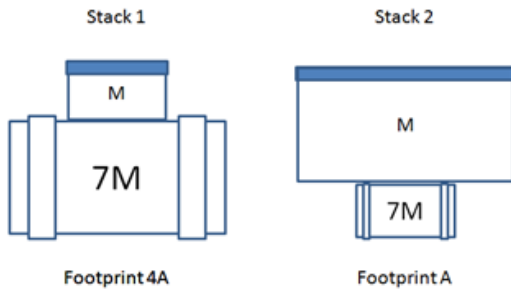

- .11 When the CTU is static, the pressure will remain constant (at static mechanical stress), but once the CTU starts to move then the vertical value of g , and therefore the force applied, can change. This change, especially increases in pressure needs to be considered when planning packaging and will be discussed in more detail later in this document.
- .12 CTUs such as intermodal containers are designed to carry a specific maximum load. In modern containers the value is approximately 28 tonnes. For 20ft unit the minimum floor area is 13.67 m^2 which means that when the load is evenly distributed across the floor there is a load of $2.04 \text{ tonnes} / \text{m}^2$. In terms of pressure this equates 20.09 kPa .

Stack 1	Stack 2
$P = \frac{800 \times 9.81}{0.48}$	$P = \frac{800 \times 9.81}{0.12}$
$P = 16,350 \text{ Pa}$ or $P = 16.35 \text{ kPa}$	$P = 64,400 \text{ Pa}$ or $P = 64.40 \text{ kPa}$

$$P = \frac{M \times g}{A}$$

Container

$$P = \frac{28,000 \times 9.81}{13.67}$$

$P = 20,094 \text{ Pa}$
 or
 $P = 20.09 \text{ kPa}$

- .13 Consider stack 1 where the total mass of the stack is 800 kg and the foot print is 0.48 m^2 , the pressure is 16.36 kPa , whereas stack 2 with a footprint of 0.12 m^2 , produces a pressure of 65.4 kPa onto the floor.
- .14 Stack 2 is exerting too greater a pressure onto the floor and in this configuration should not be packed into the container.

11.2.7 Dynamic stresses

- .1 Dynamic mechanical stresses are primarily caused by acceleration arising from changes in direction or speed. Acceleration values are particularly high if these changes occur rapidly. Let's look at some examples of this:

- .2 The Buggatti Veyron Super Sport can accelerate from 0 to 60 mph (96.6 km/h) in 2.4 seconds, which equates to a speed change of 40.2 km per hour per second or 11.16 m per second per second or 1.14g.

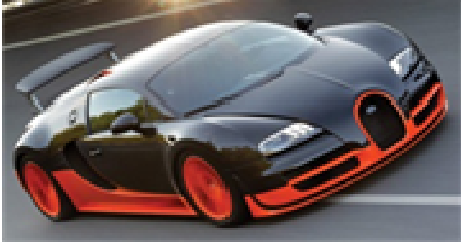

- .3 In comparison, the N700 series Shinkansen high speed train in Japan has a maximum speed of 270 km/hr and reach that speed in only three minutes. The train accelerates at 2.6 km per hour per second or 0.72 m per second per second (0.07g).
- .4 A ship which, while pitching in a heavy sea, suffers a loss of speed from 23 knots to 9 knots in the same time it undergoes negative acceleration of -5.85 kn / s or -3 m per second per second or -0.31g.
- .5 A truck travelling at 90 km/hr coming to a complete stop in five seconds is decelerating at 18 km per hour per second or 5 m per second per second (0.51g).
- .6 Mode specific stresses will be discussed in sections 14.5 to 14.7.

11.2.8 Radial acceleration

- .1 Radial acceleration refers to the force acting on a body undergoing a circular motion, i.e. going round a curve. The force is directed towards the centre of the circle and is referred to as centripetal or radial acceleration.
- .2 Radial acceleration is calculated using the speed of the object divided by the curve's radius. If a road vehicle takes a tight curve with a curve radius of 20 m at a speed of 36 km/h, which corresponds to 10 m/s, it undergoes radial acceleration of 5 m/s² or above half a "g".
- .3 Sir Isaac Newton's first law of motion (also known as the Inertia Law) states that "every body persists in its state of being at rest or of moving uniformly straight forward, except insofar as it is compelled to change its state by force impressed"† or more simply put, the velocity (speed and direction) of an object remains constant unless acted upon by an external force. What does this mean to the packer?
- .4 An object placed on the deck of that a vehicle will require continue in a straight line (inertia) unless a force (radial acceleration) is applied to it to force it to follow the same track as the transport vehicle carrying it. The lashings used to secure the object onto the deck provide that acceleration. If the object is not secured to the deck then that acceleration cannot be applied and inertia will cause it to slid outwards (reactive centrifugal force – Newton's Second Law of Motion) thus falling off the deck on the outside of the curve. By securing it lashings transfers the radial acceleration to the object.



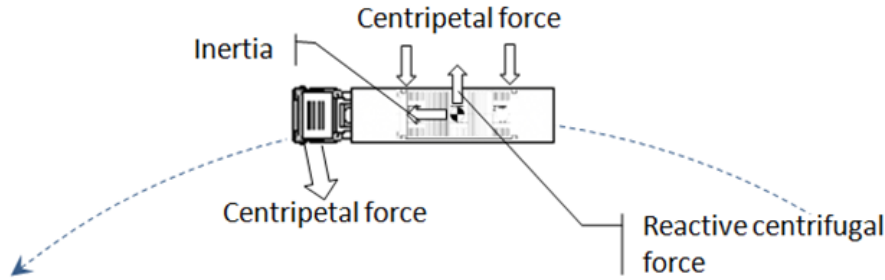

- .5 Looking at the object and its lashings in isolation. If the lashings and blocking have been correctly applied, then the object remains stationary relative to the deck. That is achieved by the lashing and blocking providing the inwards (centripetal) force and the object provides an equal and opposite force (reactive centrifugal) in the other direction.

11.3 Packing planning

11.3.1 Packing should be planned before it is started. This should make it possible to segregate incompatible cargoes and produce either a tight or secured stow, in which the compatibility of all items of cargo and the nature, i.e. type and strength, of any packages or packaging involved are taken into account. The possibility of cross-contamination by odour or dust, as well as physical or chemical compatibility, should be considered.

11.3.2 Understanding the stresses that affect a CTU and packages within them, and applying the packing requirements (section 2.0) it is possible to start the planning process.

11.3.3 There are a number of techniques that can be adopted, some of which can be used in isolation while others can be used in combination with others.

- .1 One of the earliest techniques is to produce to scale paper templates of each package footprint. These can then be positioned within a CTU floor plan. Multiple layers can be achieved through multiple floor plans. This works well in ensuring that all the packages can be fitted in, but takes no account of the mass of each and the overall distribution.
- .2 A variation on this theme is to produce a 1,200mm x 1,200mm (4ft x 4ft) grid within the loading bay area that represents the CTU floor area. A 2 wide grid can be used to represent the width and then the grid length can represent most common CTU sizes.
- .3 The use of software designed to assist in CTU packing planning are available. Such systems are generally useful with regular shaped and reasonable sized packages. Small items and irregular shaped packages may prove too complex for the system.

11.3.4 The objective of these system is to assist the planner in placing packages within the CTU and ensuring that there is sufficient room, that the packing requirements are complied with and the load distributed over the entire CTU floor.

- .1 Do select the most suitable container type to accommodate the cargo and prepare a pre-packing plan before commencing packing so that mass/volume considerations are covered and point loading limits are observed;
- .2 The planned cargo's mass should not exceed the maximum payload of the CTU. In the case of containers, this ensures that the permitted maximum gross mass of

the container (which includes the payload) marked on the CSC Safety Approval Plate will never be exceeded. ~~(see also annex 3)~~. For CTUs not marked with their maximum permissible gross mass, tare mass or other features, any of these values should be known before packing starts. ~~According to CEN standards, a swap body of class C (7.15 m to 7.82 m) will have a maximum gross mass of 16,000 kg and a swap body of class A (12.2 m to 13.6 m) will have a gross mass of up to 32,000 kg.~~

- .3 Never load a total mass so that the combined mass of the road vehicle and / or CTU exceed any road regulations applicable on the transit; Notwithstanding the foregoing, any height or weight limitation along the projected route that may be dictated by regulations or other circumstances (such as lifting, handling equipment, clearances and surface conditions) should be complied with. Such weight limits may be considerably less than the permitted gross mass already referred to.
- .4 Stowage planning should take account of the fact that CTUs are generally designed and handled assuming the cargo to be evenly distributed over the entire floor area. Where substantial deviations from uniform packing occur, special advice for preferred packing should be sought.
- .5 When a heavy indivisible load is to be shipped in a CTU, due regard should be given to the localized weight-bearing capability of the unit. If necessary, the weight should be spread over a larger area than the actual bearing surface of the load, for example by use of properly secured baulks of timber. In such a case the method of securing the load should be planned before packing is started and any necessary preparations should be made.
- .6 If the planned cargo of an open-topped or open-sided CTU will project beyond the overall dimensions of the unit, special arrangements should be made. It should be borne in mind that road traffic regulations may not allow such overhangs. Furthermore, CTUs are often loaded door-to-door and side by side, thus not permitting any overhang.
- .7 The centre of gravity of the packed cargo should be at or near the longitudinal centreline of the CTU and below half the height of the cargo space of the unit.
- .8 When planning the packing of a CTU, consideration should be given to potential problems which may be created for those who unpack it, e.g. cargo falling when doors are opened.

11.4 Accredited Packer

Formatted: Highlight

11.4.1 It is essential that those involved in the packing of CTUs fully understand the need for packing and securing the cargo adequately for all possible stresses throughout the CTU journey.

11.4.2 To ensure that CTUs are packed correctly, those involved with process, at a practical and managerial level should be properly trained using approved training packages. Packers who have completed such an international recognised and accredited training programme will be named as Accredited Packers and will be awarded a unique identification reference which must be used on packing documentation.

11.4.3 An accredited packer should undertake or approve:

- .1 CTU checks;
- .2 Pre-packing plans;

.3 Securing methods;

.4 Final sealing;

.5 Documentation.

[COMMENT: This needs much more explanation and discussion. This is a new concept. It is not explained WHO would “recognize” and “accredit” training programmes according to WHICH standards and requirements developed by WHOM? The COP should not introduce concepts that are not explained and cannot be understood and applied by the target audience of the COP.]

There is also a suggestion that the unique identification number for an Accredited Packer must be “used on packing documentation”. Which “packing documentation”? For what purpose? To be controlled by whom, if any? It would certainly not be acceptable if there is an expectation that the carrier should verify or control that the Accredited Packer is legitimate – the carrier has no contractual relationship at all with the packer of CTUs, and has no knowledge of, and has no business reason to know, the identity of the packer. The carrier’s contractual relationship is with the shipper, and it is that party that is ultimately responsible for the safe and secure packing of the CTU. So, if this concept of an Accredited Packer will be retained in the COP, it can only apply to and be relevant for the relationship between the shipper and the packer].

11.5 Entering the CTU

11.5.1 An enclosed space is not normally subject to continuous ventilation. It may be subject to life threatening atmospheric or physical change. Ensure a competent person assesses potential hazards before entry.

- Are labels or placards present at the outside?
- Are potentially hazardous substances liable to be present?
- Is there enough oxygen?
- Is the cargo in the container hazardous?
- Has some of it decomposed?
- Has anything leaked?
- Are there residues of any previous cargoes?
- Can the air in the space be breathed safely? If not, can the air be made safe to breathe, e.g. by adequate ventilation?
- Will the air remain safe to breathe throughout the work?
- Can unrestricted entry into the container be allowed? If not, entry should only be allowed under a safe system of work and the control of a responsible person.

11.5.2 Additional precautions that may be needed include:

- Further air monitoring
- A permit to work in the container
- Respiratory and other appropriate personal protective equipment
- Additional training and instruction
- Additional supervision
- Rescue arrangements

11.6 Safe Fork Truck use

11.6.1 Not all handling equipment is suitable for container packing. Lift trucks used for container packing and unpacking should have a short lifting mast and a low driver's overhead guard. If the lift truck operates inside the container, equipment with electric

power supply should be used. Container floors are built to withstand a maximum wheel pressure corresponding to an axle load of a lift truck of 5,460 kg or 2,730 kg per wheel. Such an axle load is usually found on lift trucks with a lifting capacity of 2.5 t.

11.6.2 If the CTU floor is at a different height level than the loading ramp, a bridging unit may need to be used. This may result in sharp bends between the loading ramp and the bridging unit as well as between the bridging unit and the CTU floor. In such cases the lift truck used should have sufficient ground clearance to ensure that the chassis does not touch the ramp when passing these bends.

11.6.3 **More to follow**

11.7 Manual Handling

11.7.1 **More to follow**

11.8 Securing materials

11.8.1 Dunnage

- .1 Dunnage materials or, more simply, dunnage, is the name used for all materials which are not firmly attached to the cargo transport unit, the cargo or its packaging, and are used to protect the load. This includes: Wooden dunnage, beams, planks, boards, wedges, plywood and hardboards, walking boards, mats, paper, sailcloth, canvas and tarpaulins; plastic and metal sheets, spray covers; cardboard and paperboard, packing paper, oiled paper and fabric paper, talcum powder etc.
- .2 Whether a material is to be classed as dunnage, segregation or load securing material does not depend on the material itself but on its application. The main functions of dunnage are:
 - Protection against sweat and condensation water
 - Protection against moisture and liquids
 - Protection against soiling and contamination
 - Protection against mechanical damage
- .3 Sweat water can occur as container sweat or cargo sweat. It is primarily the roof surfaces that are susceptible to container sweat with the sides and the floor of the container only being a secondary source of problems. Top dunnage and side dunnage can absorb sweat dripping from the container roof until they reach saturation point. This can sometimes significantly delay, or even completely prevent, moisture damage. Dunnage cannot protect against cargo sweat, although this is rarer when goods are transported in containers.
- .4 To ensure protection against moisture and liquids, cargoes which are at risk and sensitive parts of the means of transport must be shielded. A check must be made for any possible leakage in the means of transport or other cargo items. Potential causes of this could be leaky walls, doors and roofs on the cargo transport units, or damaged drums, cans and other similar packaging receptacles for "wet cargoes". The effects of wet or very moist load securing materials must also be taken into account.
- .5 Protection against soiling and contamination must be ensured. This can be caused by the presence of contaminating goods or contaminated components on the cargo transport units. Contaminating goods must also be enclosed by dunnage to prevent them from damaging other goods or parts of the means of transport.
- .6 Preventive measures are always needed to protect against mechanical damage, if contact with components on the cargo transport unit itself or other loads or load items could cause mechanical damage. For instance, it can be necessary to adequately protect the load against contact with side wall corrugations, corner posts, doors, lashing points, stanchions, edges and corners of other cargo items, load securing materials, protruding nails, screws etc. Appropriate dunnage must also be used to reduce the effects of harmful pressure forces.
- .7 The nature of the materials used must ensure that the packages or the cargo transport unit are adequately protected. The materials themselves must not be wet, moist, odour-tainted or contaminated. The quality of the material must be determined for each individual case by assessing the value and susceptibility to damage of the load, the means of transport, the intended protection and other

similar factors. The special properties of the particular type of dunnage used must be taken into account.

- .8 Wooden dunnage made of squared lumber, planks, boards, slats and battens, are very suitable for distributing pressure, bridging or lining cavities and gaps, creating air channels and enhancing friction. If wooden dunnage is laid too tightly, it impedes air circulation (this is a particular consideration for ventilated containers), causes a significant loss of stowage space and thus increases costs. Large spaces promote air circulation but can cause mechanical damage to the packages if the load-bearing area is too small. Wood easily absorbs moisture and releases it into the environment at a low vapour pressure. If it has a strong intrinsic odor or has taken up a foreign odour, it must not be used with odor-sensitive loads. Since wood can be infested by pests, only wood which has been impregnated against insects or fumigated may be used on certain trade routes. To distinguish such treated wood from normal wood, it must be appropriately stained or marked in some other way.
- .9 Wooden boards, wooden panels, walking boards, chipboard and hardboards are very suitable for distributing pressure and have a high loading capacity provided they are sufficiently thick. Since water-repellent, pest-proof or fire-retarding wood is odour-tainted as a result of such treatment or could have other harmful effects, it must virtually never be used with foodstuffs or similar items.
- .10 Mats made of rattan, bamboo, reed etc. only protect against surface dirt, not against dust. They absorb moisture and under certain circumstances release it back into the atmosphere. This can protect adjacent loads. Mats are easy to put in place and roll back up again, and do not cause any significant loss of stowage space. Provided a container is actively ventilated, mats can release back into the atmosphere any sweat or drops of water they have absorbed.
- .11 Canvas has a water-repellent impregnation and therefore not suitable for odour-sensitive goods. They are dust-tight. They impede air circulation.
- .12 Tarpaulins are watertight, dust-tight and airtight and very expensive. They must be handled with care if a long life is to be expected. It is very rare that tarpaulins will not be needed as a cover to protect against moisture and similar influences.
- .13 Jute coverings protect against surface dirt but not dust. They are breathable and allow a minimal amount of ventilation. They pass on absorbed moisture to the wrapped or surrounding cargo items. When used with fatty organic goods, jute coverings can spontaneously ignite or promote the spontaneous combustion of other goods.
- .14 Plastic sheeting is available in a number of different thicknesses. It is neutral in odour, inexpensive and generally acid-proof and alkali-proof. It is watertight, dust-tight and airtight but only impervious to water vapour to a limited degree. It has a low loading capacity if it is not sufficiently thick. Composite sheeting is often very heavy-duty but comparatively expensive.
- .15 Paper, e.g. normal kraft paper, is inexpensive and dust-tight, but very sensitive to moisture. Fabric paper has a higher strength. Oiled paper is watertight. Tissue paper is acid-free.
- .16 Dispersible material such as talcum powder and similar materials can be used to prevent cargoes from caking together.
- .17 Depending on their use and application, a distinction is made between:

- Floor dunnage
- Interlayer dunnage
- Top dunnage
- Side dunnage

.18 Floor dunnage is used for the following tasks:

- Dissipating and localising sweat and moisture.
- Protecting the load from moisture and dampness on moist or wet stowage surfaces or stowage spaces.
- Dissipating or restraining moisture leaking out of the load, to protect other packages or the cargo transport unit.
- Protecting the load from soiling, contamination or mechanical damage from the stowage surface or stowage spaces.
- Protecting the cargo transport unit against negative influences from the goods.

.19 Side dunnage has similar functions to floor dunnage:

- Protection against damp or moisture penetrating from the side as a result of sweat or leakage from other cargo, but also protection of other cargo or of the means of transport against liquids escaping from the side of a load.
- Protection against soiling and contamination on the sides, both of a single load against other loads or from parts of the means of transport, or protecting the latter against a specific load.
- Protection against mechanical damage or other damage, such as chafing, tearing, chemical reactions etc. both with regard to a specific cargo and to other cargoes or parts of the means of transport.

.20 Top dunnage is laid to prevent the consequences of leakage, sweat formation, bad weather, vertical shipping loads etc., which could damage a particular cargo or the cargo transport unit and its components. The main functions of top dunnage are:

- Protection against damp or moisture penetrating from the top or escaping upward.
- Protection against dust or substances which threaten contamination or chemical reactions, either penetrating from the top or escaping upward.
- Protection against mechanical damage anticipated to arise from above or acting in an upward direction.

11.8.2 Fibre ropes

.1 Fibre ropes are divided into:

- Natural fibre ropes; and
- Synthetic or man-made fibre ropes.

.2 Natural fibre ropes are no longer used for load securing in most industrialized countries. In some countries, however, natural fibre ropes may be used for securing loads in or on specific cargo transport units. However natural fibre ropes are very sensitive to acids, alkalis and solvents and mould and other microorganisms attack the fibres. Natural fibers swell when they absorb moisture and shrink on drying. Fluctuations in moisture content result in considerable changes in the length of ropes:

- The ropes become shorter when wet;
- The ropes become longer when dry.

For the above reasons, it is very difficult to maintain uniform tension with fibre ropes.

- .3 The main raw materials for synthetic fiber ropes are:
 - Polyester (PES)
 - Polyamide (PA)
 - Polypropylene (PP)
 - Polyethylene (PE)
- .4 Polyester exhibits exceptionally good behaviour with acids, alkalis and solvents and also only loses very little strength due to natural weathering; it is therefore very UV-stable. Polyester ropes are not purchased for load securing purposes, however, as they are relatively expensive.
- .5 Polyamide (generally known under its trade names nylon, perlon etc.) exhibits good behaviour with alkalis and solvents but is sensitive to acids. It loses around 20% of its strength per year from natural weathering, especially UV radiation. Because of its price, polyamide is rarely used for load securing purposes.
- .6 Polypropylene exhibits very good resistance against acids, alkalis and solvents. If it is not stabilized, however, it is very sensitive to natural weathering. For this reason, polypropylene ropes should always be light and heat stabilized. Black dyed ropes are best suited for this. Their strength only decreases at around 5% per year from natural weathering.
- .7 Polyethylene has no place in load securing on account of its poor mechanical properties. It is even banned for use as slinging ropes.
- .8 The MSL (Maximum Securing Load) of fibre ropes is 33% of the breaking load. As an example the breaking load of 5 mm thick polypropylene can be calculated with a rule of thumb using the formula $12 \times d^2$, the MSL is 1 kN or 100 daN.

11.8.3 Steel ropes

- .1 The type of steel wire ropes mainly used for lashing is cross-laid stranded ropes laid to the right. Stranded rope is the designation for a wire rope construction where the individual wires are laid into strands and these are in turn laid into the finished product. The number of individual wires and strands significantly influences the pliability of the wire and its price. The more individual wires there are in a wire rope, the more flexible but also the more expensive it is. A frequently used construction consists of 6 strands each with 19 individual wires per strand, with a fibre core to fill the cavity remaining in the centre. The fill factor for rope constructions of this kind is around 0.455, i.e. the cross-sectional area occupied by metal accounts for around 45.5% of the total cross-section. Wire ropes with the construction 6 x 37 + 1 FC are also favoured.

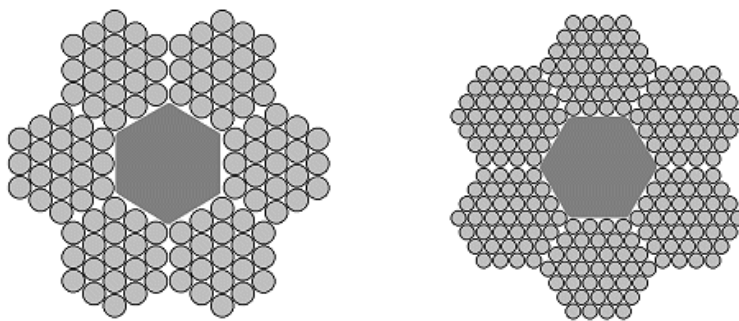

- .2 The construction of the wire rope dictates the breaking load, but the two designs shown have a braking load that can be calculated using the formula of diameter² x 50 (d x d x 50) The breaking load of other designs can be significantly lower, therefore it is important to confirm the breaking load of the steel wire before use.
- .3 In general the MSL of wire rope is 80% of the breaking load again this varies with different designs and use.
- .4 Running wires around sharp edges will lower their MSL. There are precise values, but a number of additional factors should be taken into account. Rough but nonetheless usable values are provided in this easily remembered table:

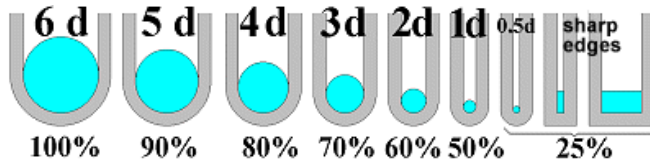

11.8.4 Wire rope lashing

- .1 Wire ropes with spliced or pressed eyes are rarely used for lashing. Generally, wire cable clamps (clips) are used to connect to other lashing elements, such as turnbuckles, shackles, lashing rings etc. There are suitable clips available for every thickness of rope, in both metric and Imperial sizes. For a 12 mm wire, 12 mm or ½" clips are required. For 16 mm wires, 16 mm or 5/8" clips must be provided.
- .2 When forming a wire rope stop or lashing it is important that sufficient clips are used to ensure the maximum MSL. Typically four clips are required, each contributing 25% of the load. Therefore a stop with only one clamp will have an MSL of only 25% of the wire rope capacity. Likewise insufficiently tightening the clamps will render the clip useless.
- .3 The way that the clamps are attached also can contribute to the performance of the stop:



- This type of attachment is advisable if relatively long lashings have to be made.

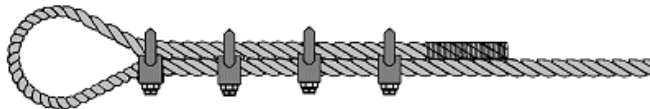

- This construction is often used for shorter lashings.

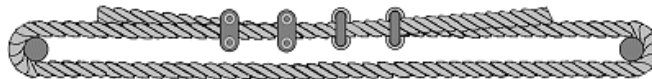

- The correct format should always be used for relatively short lashings because it is the most resilient. Inadequacies such as the presence of sharp edges can also be counteracted with this method.

- .4 Associated with the strops as shown above, it is essential that tensioning devices are used as insufficient tension can be achieved when making up such wire rope strops.



- .5 Tensioning devices and wire rope strops are generally attached to the CTU using shackles or hooks, therefore a strop can consist of two shackles, a wire rope strop and a tensioning device. Each of these will have a safe working load and care should be taken to ensure that the weakest element within the system is used when calculating the size of the strop and number to be used.

11.8.5 Steel strapping / banding

- .1 Steel strapping can be applied quickly and easily and is therefore suitable for securing purposes on many loads.
- .2 Steel straps have a very high breaking strength and this is a common selling point. The disadvantage of steel straps, however, is their low elasticity. This ranges from around 0.25% to a maximum of 0.5%. Steel straps are therefore not really suitable for use as tie-down lashings.
- .3 For instance, if a lashing is 7 m long, an ordinary commercial steel strap would have an elasticity of $7 \text{ m} \times 0.0025 = 0.0175 \text{ m}$ or 17.5 mm. About half of this is exhausted for pre-tensioning, which means that just 8-9 mm remains. If the circumference of the lashing is reduced by this amount due to the strap cutting into the wood of cases, shifting of goods etc., the steel strapping will become loose and no longer able to fulfil its function as a securing aid. Further jolts during transport then produce greater forces on account of the resulting acceleration forces which can cause the steel strapping to tear.
- .4 Steel strapping also requires that the seals are applied correctly.



11.8.6 Lashing chains

- .1 Lashing chains are generally only used to secure container cargoes if the chains will be returned. On very valuable cargoes, however, it may also be worthwhile to use them as a "lost load securing aid", because of the benefits offered by their high strength and speed with which they can be deployed.
- .2 Since lashing chains are made of high strength steel, there are no rules of thumb for calculating the breaking loads. The manufacturer's specifications should be observed. The MSL may be assumed to be 50% of the breaking load. A range of different tensioning mechanisms are used with chains. Errors are frequently made when using these aids.

.3 Chains can be tensioned using levers or turnbuckle devices. However it is important to remember that both of these can be attached correctly and safely, or incorrectly with the risk of failure and loss of cargo.

.4 The tension levers must be swung so that the angle between the lever and the chain is at an angle of approximately 45°. The picture shows an example where the tensioning lever has not been pulled through sufficiently and an angle of approximately 90° achieved. On this state the tongues could buckle or shear off



.5 Tensioning can be also achieved using a turnbuckle with a hook at each end, which can be used as a terminator (i.e. at the end of the chain where it attaches to the CTU or as an intermediate device, where the turnbuckle is used to shorten a length of chain already attached, one end to the CTU and the other to the package.

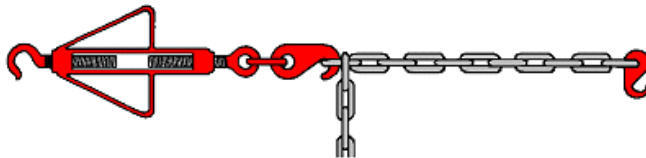

.6 No rules of thumb are provided in the CSS code for high strength chains, because the diversity of the products is very high. There are chains made to all kinds of different standards on the market. If the stamp on the chain and its accessories clearly identify it as quality class 8, the rule of thumb $d^2 \times 120$ can be used to calculate the breaking load. The MSL is to be assumed to be 50% of the breaking load. This produces the following figures for the following diameters of chain steel:

11.8.7 Lashing belts

.1 Pre-fabricated lashing belts are generally supplied as a kit of two lengths of woven strap material, each with an attachment hook and on one (often the shorter) there is a ratchet operated tensioning device.



.2 In relation to all lashings used, the proportion of pre-fabricated lashing belts is small, since the belt systems can only be returned with specific shipping companies and cargo types. Flexibility suffers in day-to-day lashing operations as a result of fixed lengths and sewn-in end fittings. Due to the speed with which they can be applied, however, the proportion of these lashings being used is constantly growing. If lashing of this kind is used, however, it should be applied out correctly and professionally.

.3 Pre-fabricated lashing belts will always be supplied with an information label that shows the permissible lashing force.

- .4 A simpler lashing belt is often supplied in long lengths and cut to size and a buckle used to tension the belt by means of a separate tension device. The belts are often very light but with extreme strength, such as Kevlar belting.
- .5 One of the possible disadvantages of this design is the tensioning ratchet can produce high values of tension on the strapping which may overload the CTU lashing rings and bars.



- .6 There are lighter versions which are generally tensioned using a simple buckle that is tightened by pulling the belt through by hand. Such belts are generally used for light packages and can loosen with vibration.
- .7 All woven belts are susceptible to damage when they pass over sharp edges and corners and it is recommended that edge protectors are used.

11.9 Basic principles for packing and securing

11.9.1 There are a number of terms used in packing which are explained below:

.1 Packing for ready access

A load must be immediately accessible. Ease of access may apply to a specific (intermediate) destination, For example, dangerous cargoes consignments which form only part of the load of a CTU should, whenever possible, be packed adjacent to the doors with markings and labels visible.

.2 Top stowage" (occasionally "**on-top-stowage**")

No further items are stowed on top of the load. This instruction is not to ensure that a batch should be readily accessible, but is issued because packages are particularly sensitive or fragile. If stowage of this type is required, appropriate indications must be attached to the packages. Written instructions such as "Do not overtop", "Please load on top" etc. are not necessarily universally understood. Sensible, comprehensible markings can be more effective.



.3 Stowing or packing correctly for a fork-lift truck or a crane

The appropriate arrangements must be made to ensure that the goods can be lifted by a ground conveyor or lifting gear without requiring special preparation and without any time delay. The dimensions, strength and loading capacity of the aids used, such as squared lumber, wooden dunnage boards etc. must ensure that the goods do not suffer any damage during shipping. If necessary, stowage surfaces must be prepared with walking boards, boards, cargo items with a high loading capacity or other usable aids, so that work can be carried out safely and the batches that have already been loaded can be overtopped with other loads.

Bottom and intermediate dunnage must be arranged so that forks, strops, chains, claws and similar cargo handling equipment and slinging equipment can be used without any problems.



.4 Tier

A layer or stack. It can mean either horizontal layers of cargo or cargo items stowed vertically one above the other. If



circumstances do not make it clear from the outset what type of layer is meant, it makes sense to distinguish between a vertical tier and a horizontal tier.

The stowage position on board container ships is generally documented according to the bay-row-tier system or the bay-tier-row system. In this specific case, "tier" designates the horizontal layers of containers. Layers are counted from the bottom to the top.

.5 Loaded upright or loaded on its side

This relates to the shape of the consignment items. In most cases, the meaning is clear.



Beam is upright

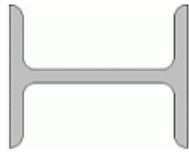

Beam is on its side



Rail is upright



Rail is on its side



Disk is upright



Disc is on its side

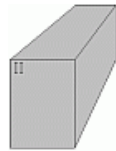

Box is upright

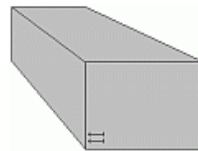

Box is on its side



Drum is upright

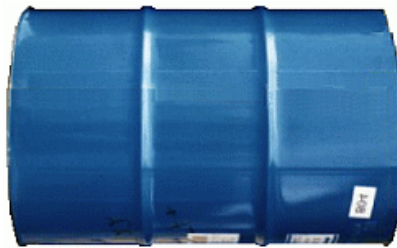

Drum is on its side

The same applies for wheel rims, pipes, steel bars, narrow wire rod coils and other loads. It is also rare for these to be confused.

With cylindrical, or roller-shaped goods, the expression "upright" should really be used uniformly. Such cargo items are generally understood to be "upright" if

- the axis is vertical and the length of the axis is greater than the diameter or
- the axis is horizontal and the length of the axis is less than the diameter.



Paper roll is upright



Gas cylinder is upright



Coil is upright



Coil is upright



Tire is upright

The expression "on its side" also has a standard meaning for the same goods. By definition, cargo is "on its side" if

- the axis is horizontal and the length of the axis is greater than the diameter or
- the axis is vertical and the length of the axis is less than the diameter.



Paper roll is on its side

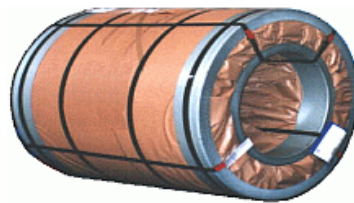

Coil is on its side



Gas cylinder is on its side



Coil is on its side



Tire is on its side

Differences in understanding of these terms, sometimes regional, however, can lead to errors and misinterpretations and thus incorrect stowage.

Another problem arises if the length of the axis and the diameter are almost the same size. This can easily lead to misinterpretations of the terms in practice:



Is the coil upright or on its side?



Is the roll upright or on its side?

Incorrect expressions in the loading instructions or an incorrect interpretation of correct instructions frequently lead to damaged cargo. Such damage can be avoided if a reference is made in the stowage instructions to the orientation of the axis. Instead of the formulations "Load rolls upright" or "Load rolls on their sides", the expressions "Roll axis vertical" ("eye to the sky") or "Roll axis horizontal and transverse" or "Roll axis horizontal and longitudinal" should be used.

Misleading formulation	Clear formulation
... load so that	... load so that
Wire rod coils are upright	Ring axis/winding axis positioned vertically (English: "eye to the sky")
Wire rod coils are on their sides	Ring axis/winding axis horizontal (English: "eye to lie") or even better: ... Ring axis horizontal longitudinally...or horizontal transversely
Cylinders are upright	Cylinder axis is vertical
Cylinders are on their sides	Cylinder axis is horizontal, or even better: Cylinder axis is horizontal and longitudinal Cylinder axis is horizontal and transverse

As already mentioned, the terms "upright" and "on its side" are clear for most cargo items such as billets, pipes, profiles, bars etc., but it can be necessary in certain cases to provide or request more precise stowage instructions, such as "lying on its side" etc.

.6 Stacking

Stacking means loading, packing or stowing packages in layers so that the edges of the packages lie flush above each other.

High load levels are produced when stowing cargoes in layers with intermediate layers made of squared lumber or wooden dunnage, since only linear bearing surfaces are produced in the area of the bottom and intermediate layers. Only cargoes insensitive to load forces may be stowed in this way. Harmful pressure can be reduced to an acceptable level by using relatively soft wood or by using intermediate layers made of rubber.

.7 Cross-tie stow.

In principle, this involves the cargo items interlocking with each other. It can generally be used to minimize the effort required for securing cargo. Methods like this improve the stability of the cargo. But, as we have said: This method may only be used with resilient goods. Remaining gaps must be filled. Wooden dunnage and similar intermediate layers should also be used as anchors. The need to bridge or pad out stowage gaps can result from a difference in the dimensions of cargo items.

.8 Complete transverse cross-tie

This refers to stowage in which goods fill the stowage space from side wall to side wall. Anchors do not need to be inserted if equivalent measures are taken. This stowage method is suitable for all means of transport having load-bearing side walls or with low lateral stresses, e.g. in rail transport. If the walls of a cargo container are not sufficiently strong, the cargo items must be stowed as a cross-tie, interconnected with anchors or secured using other special measures. It should always be considered that the speed of unloading can be increased by selecting the right anchor materials. The use of mechanical aids should be encouraged and not hindered in any way. Some examples of a complete transverse cross-tie have already been provided under the other stowage methods.

.9 Diagonal stowage

This technique can be practicable under certain circumstances, from the point of view of loading and unloading, on flatracks, trailers, container bolsters, trucks, certain types of freight car and similar vehicles, so that a number of teams can work at the same time. With this method, cargo of the same type or goods destined for the same recipient are loaded diagonally, to enable the cargo items to be accessed as quickly as possible. In contrast to conventional ship cargo, all goods must be destined for a single place of unloading. Onward transport with remaining diagonal load blocks is not possible.

.10 Bilge and cantline

This refers to a loading method in which packages are stowed or fitted into indentations produced by the round or rounded shape of other packages.

Genuine bilge and cantline stowage "on the quarter" is produced when stowing wooden barrels. This stowage method is only used very rarely nowadays.

If sensitive cylindrical cargo is stowed using the bilge and cantline method, the load forces are transferred over two load-bearing lines onto the cylinders stowed below. The cylinders in the bottom layer only rest on one load-bearing line. If wooden dunnage or squared lumber is laid as floor dunnage, only load-bearing "dashes" are present for each cylinder, which can cause harmful load forces. Items stowed using the bilge and cantline method exerts considerable forces on the layers below them as a result of their opening angle. Only precise stowage can minimize these forces.

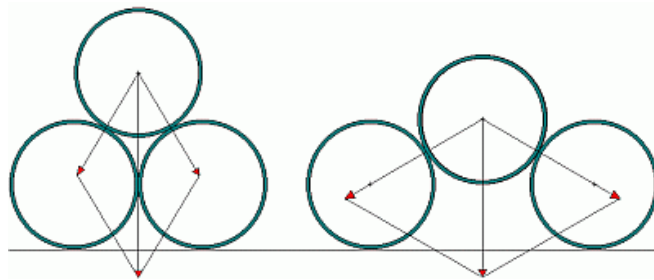

It should be remembered that at an opening angle (angle between the centres of the two supporting objects) of 120°, a package already exerts a force of double its weight on the underlying packages and at 151°, this force is even four times its weight. If packages of this type are in turn bearing heavy loads, they will exert extreme downward forces.

If cylindrical goods are loaded with stowage gaps and stowed with the bilge and cantline method, a cargo item which protrudes low into the cantlines of the underlying layer could exert considerable lateral forces on the stanchions or other edges of the loading area. This would result in damage to the cargo and/or damage to the CTU.

.11 Cross tie stow

Packages are stowed alternately longitudinally and transversely. In this way, they are firmly interconnected.

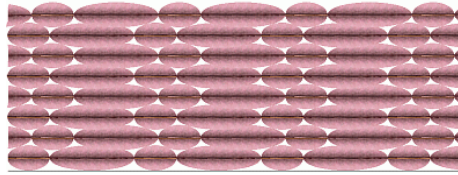

.12 Chimney style stow

Chimney-style stowage is extremely well suited for forming pre-slung cargo. With palletised packages, it is suitable for certain bag sizes. The packages are arranged layer by layer so that they overlap around a cavity. Each are thus connected to each other. This produces a square or rectangular footprint, which is very suitable for packing containers if it has the correct dimensions.

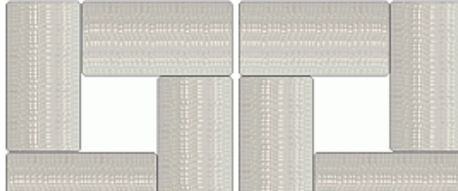

.13 Soldier stow

A stow where packages are stood in lines within the CTU. Often used for drums, but rectangular packages can also be stowed using this method.

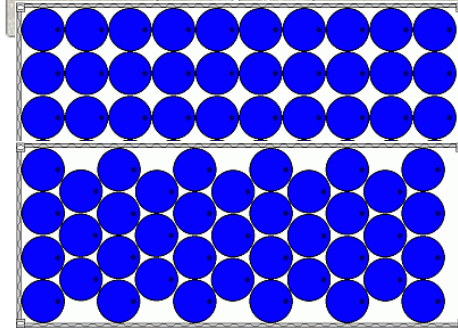

.14 Off set soldier stow

Sometimes referred to as the vertical bilge and cantline stow. Used when it is impossible to complete a proper soldier stow due to width restrictions.

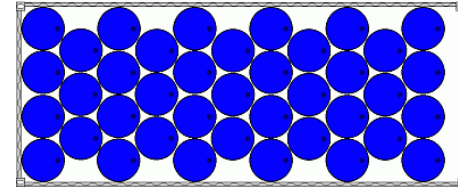

.15 Nesting

A nested stow reduces loss of stowage space or can be used to create level cargo surfaces for access with fork-lift trucks. Some variants have their own names. Manually stowing on site is also becoming increasingly rare for this method, as it is growing much more common for cargo to be stowed in bundles beforehand at the factory.



.16 Face stow

Face stow refers to the loading of coils, rolls etc., with their axis oriented parallel to the longitudinal axis of the skid or means of transport.

.17 Braiding

This packing method involves placing ring-shaped loads, such as tires, wire rod coils with a short winding axis etc. in the core of other ring-shaped loads. Braiding has lost its importance through the use of special vehicles and the now common practice of transporting smaller batches in containers. The method is still used, however, on complete loads or fairly large batches.

11.9.2 Restraining methods are principally the following:

- locking,
- blocking ,
- direct lashing,
- top-over lashing and
- combinations of these

in conjunction with friction

11.9.3 The restraining method(s) used should be able to withstand the varying climatic conditions (temperature, humidity...) likely to be encountered during the journey.

11.9.4 Blocking

- .1 Blocking or bracing means that the cargo is stowed to lie flush against fixed structures and fixtures on the load carrier. These may be in the form of headboards, sideboards, sidewalls or stanchions. The cargo can be stowed directly or indirectly by means of filling against the fixed blocking devices built into the load carrier, and these prevent any horizontal movement of the cargo.

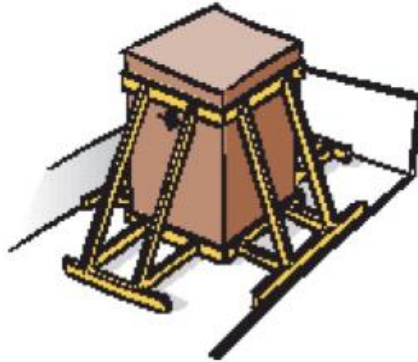

- .2 Bracing elements made of wood are a tried and tested method of load securing when packing containers. Squared lumber, battens and other elements are fitted in in such a way that spaces within the load are bridged. Bracing between the cargo and the container, and between the items of cargo are both commonly used methods. The latter is the more cost-effective solution since the required securing forces are generally lower.
- .3 Wooden bracing elements used to fill in gaps or empty spaces can often be made quickly and simply. Occasionally, however, they are feats of craftsmanship that require a great deal of experience and ability. In practice it is difficult to achieve a tight fit against the blocking devices and a small clearance usually remains. Gaps must be kept to a minimum, especially those to the headboard. The cargo should be blocked against the head board either directly or by the use of filler material in between.
- .4 Be aware that the loaded packages also have to be secured to the CTU. If the load is uniformly distributed, total maximum sideways gaps must not exceed 80 mm for packages to be considered as properly blocked between sidewalls.. With heavy concentrated loads, any gaps should be avoided. Improperly blocked packages need supplementary securing measures to the CTU.

11.9.5 Blocking with filler

- .1 Effective securing of cargo by blocking requires close stowage of the packages both against the load carrier's blocking fixtures and between the individual packages. When the cargo does not fill the space between the side and end boards, and is not otherwise secured the gaps must be filled with a filler material to create compressive forces that ensure a satisfactory blocking of the cargo. These compressive forces should be proportionate to the total cargo weight.



Some possible filler materials are shown hereafter.

- .2 Goods pallets

Goods pallets are often a suitable form of filler material. If this clearance towards the blocking is larger than the height of a EURO pallet (about 15 cm) then the gap could be filled with, for example, such pallets standing on end, for the cargo to be properly blocked. If the clearance towards the sideboards on any side of the cargo section is smaller than the height of a EURO pallet then the gap to the sideboard must be filled with suitable filling, for example planks of wood.

.3 Inflatable dunnage bag

Inflatable dunnage bags are available both as disposable items and as recyclable products. The cushions are easy to install and are inflated by compressed air, often by means of an outlet in the truck's compressed air system. Suppliers of air cushions are expected to provide instructions and recommendations concerning load capacity and appropriate air pressure. For air cushions it is important to avoid damage as a result of wear and tear. Air cushions should never be used as filler against doors or any non-rigid surfaces or partitions.

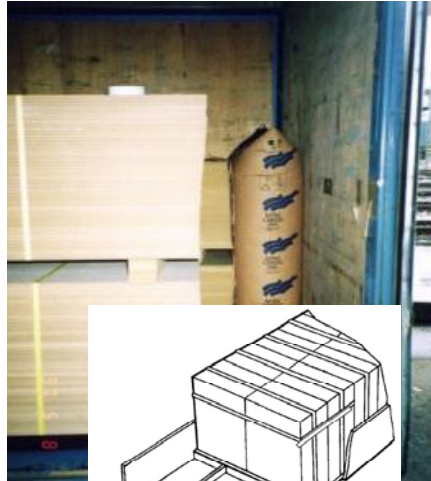

11.9.6 Blocking braces

When there are large gaps between the cargo and blocking fixtures, and high bracing forces, it is often appropriate to use blocking braces fitted with sufficiently strong wooden spacers. It is essential that blocking braces are fixed in such a way that the spacers are always at right angles to the cargo that is being braced. This will ensure that the blocking braces are more able to resist the forces exerted by the cargo.

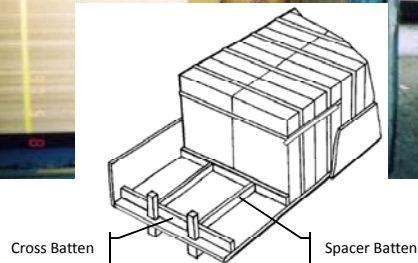

11.9.7 Diagonal and cross battens

Blocking in longitudinal direction by means of diagonal and cross battens is a direct blocking method particularly suited to containers, where the container's robust and vertical corner beams are used as counter holds for diagonal battens. Blocking braces are used for longitudinal base blocking, but can also in certain cases be used as filler material.

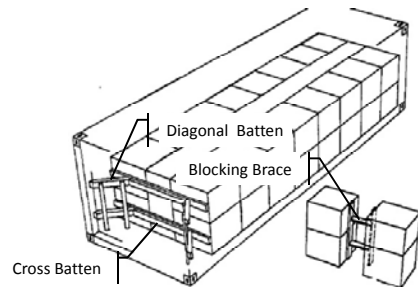

11.9.8 Threshold blocking and panel blocking

- .1 When there is a height difference between various layers, threshold blocking or panel blocking can be used for base blocking of the upper layer against the lower layer. Using some form of base material, such as load pallets, the cargo section is raised so that a threshold is formed, and the upper cargo layer is base blocked longitudinally.

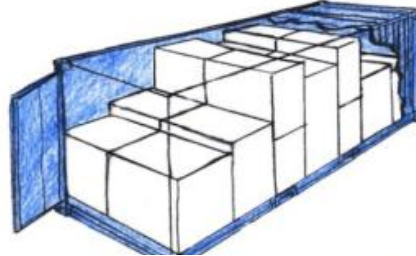

- .2 If the packages are not sufficiently rigid and stable for threshold blocking, a corresponding blocking effect can be achieved by using a panel blocking method.

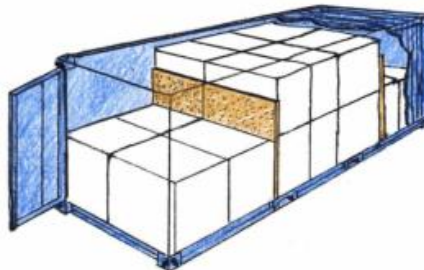

achieved by using panels consisting of boards or load pallets as shown in the figures below. Depending on the rigidity of the cargo packages, a blocking structure can be created to provide a large or small blocking surface.

- .3 When threshold or panel blocking is used at the rear, at least two sections of the bottom layer must be behind the blocking section.

11.9.9 Blocking between rows within a cargo section

- .1 Cross bracing in the form of frames (the lower left picture) is used for blocking various layers laterally (known as layer blocking).
- .2 Threshold blocking sideways can also be achieved if the packages have different heights or if vertical planks or panels are placed between the rows.
- .3 Row blocking can be achieved by use of stacking cover as shown on the upper figure in the picture below.

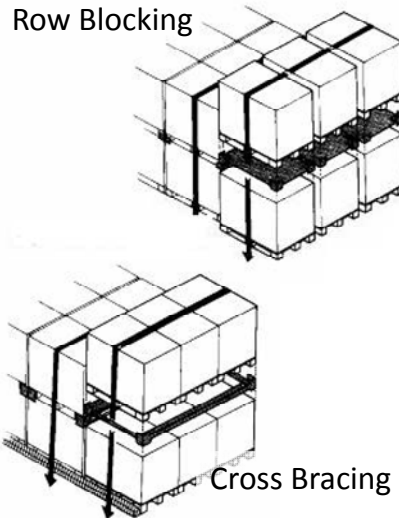

11.9.10 Wooden battens nailed to the load platform

On load carriers that have robust wooden platform beds of good quality, base blocking can be achieved by nailing wooden battens directly to the floor. The maximum closure force per nail can be found in Annex 8.3.

11.9.11 Wedges and wedge beds

- .1 Pointed wedges and block wedges can be used to prevent cylindrical objects moving along the loading platform (see picture below).
- .2 Block wedges should have a minimum height of $R/3$ (third of the roll radius) if there is no top-over lashing. If used in conjunction with top-over lashing, no more than 200 mm is required. The angle of the wedge should be approximately 45° , as shown below.

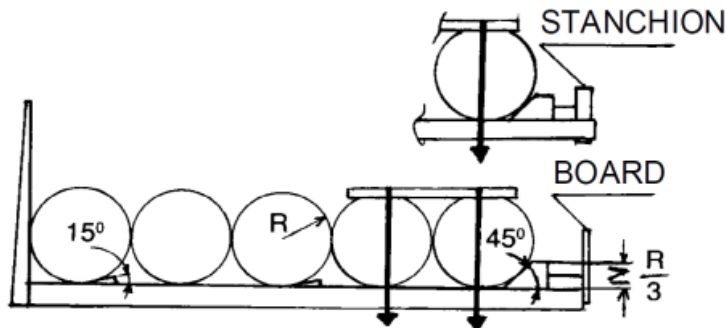

- .3 If wood wedges are nailed to the floor, caution should be taken to ensure their strength is not reduced.

- .4 Pointed wedges, normally with a 15° wedge angle, have no cargo securing capacity, and their chief function is to keep round shaped goods in position during loading and unloading. The small angle means that the wedge normally self locks to prevent sliding.
- .5 Block wedges (approximately 45o) are used as blocks to prevent rows of round shaped goods from shifting, and must therefore be blocked against suitable blocking devices on the load carrier. The rolls must also be lashed against the platform bed, with an edge beam and top-over lashing being required over both the rear rolls.

11.9.12 Wedge bed

- .1 The two long wedges are kept in position by adjustable cross bracing such as bolts or chains. The cross bracing should be arranged so that a minimum clearance of 20 mm is achieved between the roll and the platform bed in order to ensure the wedge bed is prevented from moving sideways.
- .2 The height of the wedges should be:
 - minimum R/3 (third of the roll radius) if there is no top-over lashing or,
 - maximum 200mm in combination with top-over lashing.

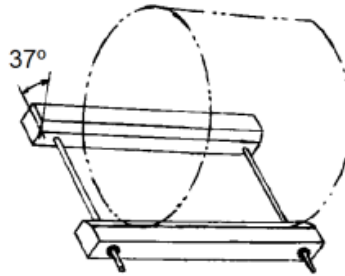

(the angle of approximately 37° comes from the Egyptian rectangular triangle, whose sides are in the proportion of 3, 4 and 5).

11.9.13 Lashing

- .1 Lashing refers to the use of steel strapping, chains, steel wire, textile straps, ropes and other securing materials which are fixed, on the one hand, to the package and, on the other hand, to the CTU and then tensioned lightly. The important factors that determine the effectiveness of the lashings are the quality of the materials and the fixing points as well as the directions in which the lashings work. This means that lashing angles also play a critical role. Lashing a package is intended to prevent it from moving longitudinally or laterally and to stop it rising from the loading surface or tipping. A lashing is used to create a tight fit. The term direct lashing is also used.
- .2 The quantity and thickness of the required lashings will depend on the weight of the load that is to be secured, on the anticipated forces, on the maximum securing load of the lashings and the lashing angles. More information can be found in the relevant sections dealing with the materials and in the lashing examples.
- .3 Lashing has a less important role to play when securing packages in ISO containers. Since the lashing points in the container usually have a maximum securing load of 1,000 daN (corresponds to a mass of approximately 1 t), the use of lashing must be restricted to lighter packages. Another consideration is the fact that lashing points are often not accessible as a result of spatial restrictions and the space occupied by packages.
- .4 Top-over lashing

Top-over lashing is a method of securing where lashings are positioned over the top of the goods in order to prevent the cargo section from tipping or sliding. If there is no side blocking at the bottom, for example top-over lashing can be used to press the cargo section towards the platform bed.

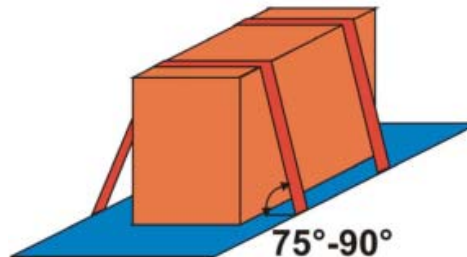

Contrary to blocking, top-over lashing forces the cargo against the load platform.

Even if friction prevents the cargo from sliding, vibrations and shocks during transportation can make the cargo wander. This makes top-over lashing necessary even if the friction is high.

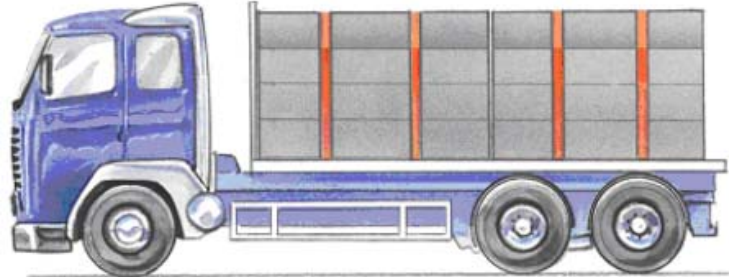

.5 Loop lashing

Loop lashing is a form of sling lashing cargo to one side of the vehicle body, thereby preventing the cargo from sliding towards the opposite side. To achieve double-action lashing, loop lashings must be used in pairs, which will also prevent the cargo from tipping over. Two pairs of loop lashings will be required to prevent the cargo from twisting longitudinally.

The loop lashing ability to sustain the required traction force depends upon the strength of the lashing points among other things.

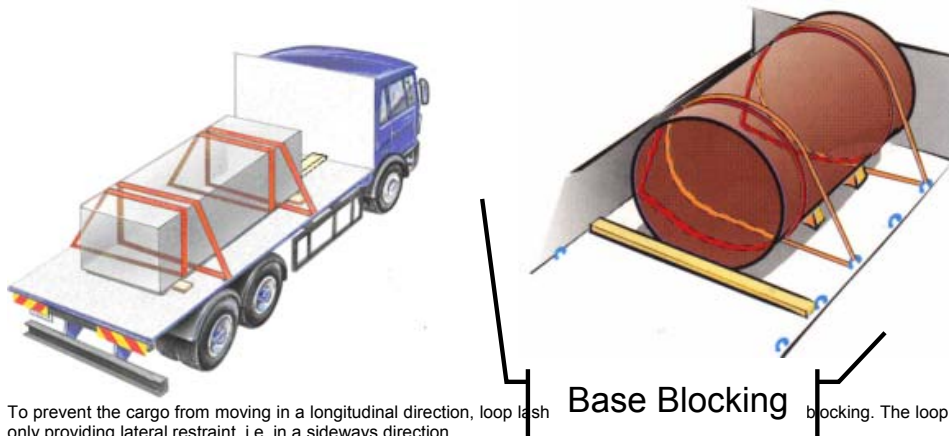

To prevent the cargo from moving in a longitudinal direction, loop lashing only providing lateral restraint, i.e. in a sideways direction.

Base Blocking

blocking. The loop is

.6 Spring lashing

Spring lashing can be used to prevent tipping and/or sliding forwards or backwards. Spring lashing in combination with base blocking forwards or backwards is a restraining method consisting of a sling (bridle) across the corner of the cargo layer and two diagonal lashings, the purpose of which is to prevent a cargo layer from tipping or sliding. Spring lashing may also be in the form of a single, closed roundsling, placed across the edge of the cargo layer and lashed by means of a diagonal lashing on each side. The angle to the cargo surface is measured in the longitudinal direction, and it is recommended that the angle is not more than 45°.

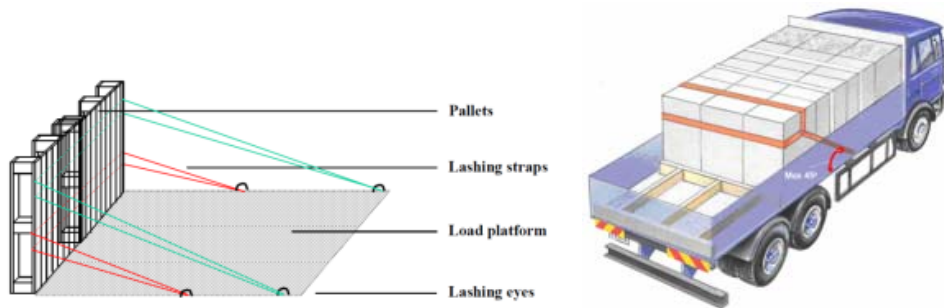

A diagonal lashing with corner strap must be calculated taking into account the angle, the friction and the lashing capacity (LC) given on the label of the lashing as required by such standards as EN12195. Two opposite pairs of diagonal lashings with corner straps may also be used as an alternative to round-turn lashing.

.7 Round turn lashing

Round turn lashing is, in combination with other forms of securing, a method to bind a number of packages together. Horizontal round turn lashing is applied by binding a number of packages together in cargo sections and therefore reduces to some extent the risk of the cargo tipping over.

Vertical round turn cargo lashing is used to bind a number of cargo items together to stabilise the cargo section and to increase vertical pressure between the layers. Risks of internal sliding are thus reduced. Plastic or steel straps are

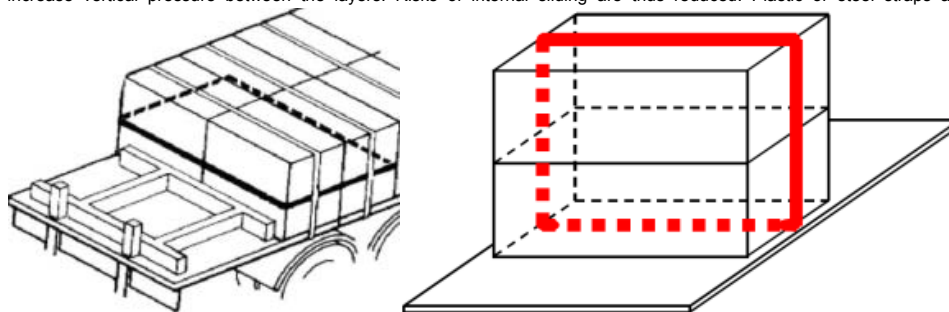

commonly used for round turn lashing.

.8 Direct lashing

If the cargo is equipped with lashing eyes compatible with the strength of the lashing, it is possible to lash directly between the lashing eyes and the lashing points on the CTU.

A purely vertical lashing (right hand) has no horizontal component at all. These lashings are thus unable to exert either a



longitudinal or a transverse securing effect. Longitudinal and transverse forces can cause the load to move. If this happens, the purely vertical lashings are displaced sideways and sometimes placed under considerable tension. The tension that is created as a result of the load moving exerts a force on the load pushing it down on the container floor. This increases the frictional forces on the floor. Frictional forces for each lashing are calculated using the product of the MSL and the friction coefficient.

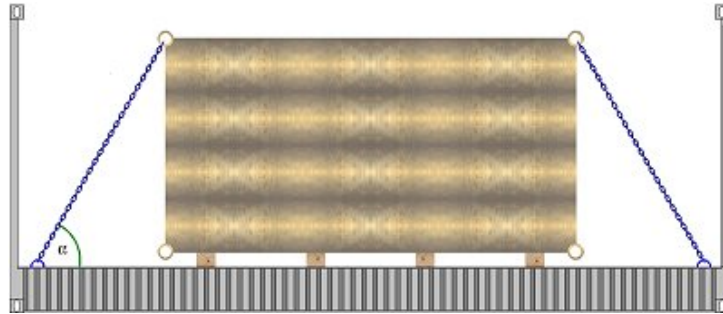

Diagonal lashings form a lashing angle α with the horizontal plane and a further lashing angle β with the horizontal longitudinal direction of the transport unit. According to the terms defined by the VDI, lashings of this type are referred to as diagonal lashings.

With the diagonal lashings shown here, the vertical components are the greatest. The horizontal longitudinal components are considerably smaller, and the horizontal transverse components even smaller still.

Cross lashings are simply a special form of diagonal lashing. These are advantageous if the lack of space requires greater horizontal components.

11.9.14 General techniques

- CTU with solid walls;
- CTU with flexible walls;
- CTU without walls.

11.10 Load distribution

11.10.1 Introduction

- .1 This section looks at load distribution and how poor attention increases the risk of an accident.
- .2 When preparing to pack a CTU it is essential that a load distribution plan developed for placing individual cargo elements within the container. Consideration should be given to three elements of the load's centre of gravity (CG).
- .3 If the mass of the cargo is not evenly distributed, its CG will be closer to where the cargo is heaviest. It is also possible that the CG of an object is not within the object, for example a boomerang shaped object will have a CG between its arms.
- .4 To ensure that packages are secured effectively, it is important to fully understand where the CG is for each package and the entire cargo within a container.
- .5 The mass of the cargo should be evenly distributed over the floor of a container. Where cargo items of a varying weight are to be packed into a container or where a container will not be full (either because of insufficient cargo or because the maximum weight allowed will be reached before the container is full), the stow should be so arranged and secured that the approximate centre of gravity of the cargo is close to the mid-length of the container. If it is not, then special handling of the container may be necessary. In no case should more than 60 per cent of the load be concentrated in less than half of the length of a container measured from one end. For vehicles, special attention should be paid to axle loads.
- .6 The cargo shall be distributed throughout the container to ensure that the centre of gravity is kept as central and as low as possible:
 - to avoid excessive tilting;

- to avoid overstressing either the container or the handling equipment;
- to avoid unacceptable vehicle axle loading: - to avoid lack of vehicle stability: - to avoid unacceptable load concentrations.

- .7 Eccentricity of the centre of gravity for the loaded container varies with the distribution of load within the container: designers of containers and handling equipment should take this fact into account. As an example; when 60 per cent of the load by mass is distributed in 50 per cent of the container length measured from one end (figure 7.3) the eccentricity corresponds to 5 per cent.

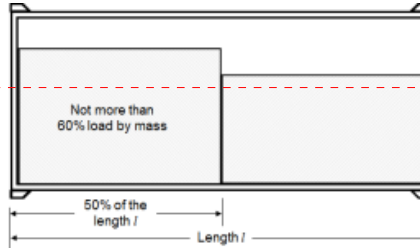

Formatted: Highlight

[The COP is not oriented towards designers of containers – who in any event may presumed to fully appreciate the issues regarding the centre of gravity – but packers and others]

- .8 On rail and maritime transport the direction of the longitudinal eccentricity makes little difference, however to ensure that axle loads are not exceeded when being transported by road it is essential that the position of the CG is suitable for the road vehicle being used. An example demonstrating the positioning of the cargo is shown in Best Practice Guidelines on Cargo Securing. [Why not include the example in the COP?]

Formatted: Highlight

11.10.2 Objectives and conditions

- .1 A load distribution plan is the basis for placing load in a CTU so that, when transported on the road, individual axles are neither under or over loaded. For a single vehicle, the load distribution plan will only need to be drawn once and will depend on its maximum total weight and the minimum/maximum axle loads. Recalculation of the load distribution plan will need to be carried out if any characteristics of the vehicle are changed, such as a body change for example. Any machinery mounted on the vehicle (vehicle mounted cranes, forklifts) and vertical loads from trailers also need to be considered in a load distribution plan.
- .2 While it may appear that this section refers only to road vehicles, it also applies to containers carried on road vehicles so ensuring that the cargo's centre of gravity within the container is correctly positioned relative to the axles is essential.
- .3 Trucks that are equipped with a trailer coupling device must be treated according to their usual operating conditions. Vertical coupling loads may be considered as load (in cases where a trailer is not usually drawn) or as part of the vehicle weight (if the truck is usually used with a trailer).
- .4 Necessary data for calculating the load distribution plan:
- maximum total weight;
 - maximum payload;
 - unladen weight;
 - front axle load of unladen vehicle;
 - rear axle load of unladen vehicle;
 - maximum permitted front axle load;
 - maximum permitted rear axle load;
 - minimum front axle load;
 - minimum rear axle load (% of total weight);
 - wheelbase;

- distance front axle to foremost point of the headboard;
- load platform length.

.5 Most of this data may be taken from plates fitted to the vehicle, registration documents, type approval document or determined by measuring the vehicle. However, some of the information may only be available from the vehicle manufacturer (minimum front axle load for example).

11.10.3 Using the load distribution plan

- .1 Before the vehicle is loaded and a loading plan is developed, the weight/dimensions and the horizontal location of the centre of gravity for each piece of load carried must be determined.
- .2 A virtual loading plan may then be drawn. The horizontal location of the whole load has to be calculated, for example by calculating a torque balance around the foremost point of the load panel (or any other point of reference if more convenient).
- .3 As described hereafter, the load distribution plan will determine whether the vehicle has sufficient capacity to carry the total weight of the load at the calculated centre of gravity.

11.10.4 Developing a load distribution plan

- .1 To determine the maximum of cargo mass which may be loaded onto the vehicle taking into account the position of the centre of gravity for the entire load, the following items must be considered:
 - The rear axle load must exceed a certain minimum, if required by the vehicle characteristics;
 - The maximum load may be found for each point of the load panel by setting up a torque balance around the front axle regarding load mass, unladen and minimum rear axle load, distance from front axle to foremost point of load and wheelbase;
 - Some Member States require that the driven axle load must represent a minimum of 15% - 25% of the total vehicle or road train weight. It is recommended that the driven axle load is a minimum of 25% of the total laden vehicle weight. (curve "A");
 - The maximum front axle load must not be exceeded. Calculation is done by torque balance around rear wheel. (curve "B");
 - The maximum payload must not be exceeded. Taken from vehicle data. (curve "C");
 - The maximum rear axle load must not be exceeded. Calculation is done by torque balance around front wheel. (curve "D");
 - The front axle load shall be at a recommended minimum (20% of total weight or another value recommended by manufacturer). Calculation is done by torque balance around front wheel. (curve "E").

The maximum authorised load is the minimum of all these results.

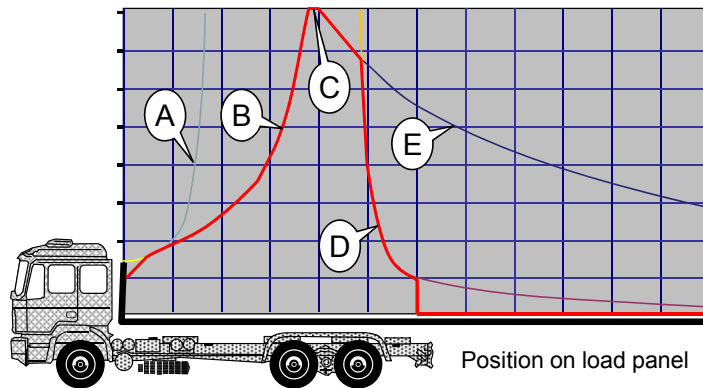

Note: Please note that the truck in the graph is a schematic picture, the dimensions do not necessarily refer to the dimensions used in the calculation example here after. Although load panel length in the example is 6.0 m, the diagram is drawn up to a length of 12.0 m to show the curves as further information.

11.10.5 Securing rules

.1 More to follow

11.11 Packing Bulk Materials

11.11.1 Portable tanks, tank containers and swap tanks

- .1 Under no circumstances should lifting of tank containers by fork lift truck be attempted. The only exception to this may be in the case of, for example, off-shore 10 foot tank containers fitted with properly designed and maintained fork lift pockets.
- .2 Many of the fittings and fixtures attached to the tank container can protrude outside of the ISO envelope when they are open or erected such as:
 - Leaving temporarily fitted steam traps on the outlet pipes of steam coils;
 - Wrapping electric cables of heating systems around corner posts in stead of placing these in the proper holder or tray;
 - Leaving temporary adaptors on airline connections;
 - Not closing manway lids full after use;
 - Not closing top outlet valve handles;
 - Not closing airline valves on top of tanks;
 - Waterlogged insulation material causing it to sag and/or bulge outside the allowable external dimensions;
 - Collapsible handrails not properly stowed away.
- .3 Note: Where any item protrudes outside of the envelope the tank container must not be shipped.
- .4 Spill boxes are fitted with a drain tube to allow waste material to be drained. However it is important to note that liquids escaping from these tubes are not always dangerous. There have been a large number of false alarms raised

because operators erroneously believed that the tank container was leaking. However on closer examination the liquid was found to be melt or rain water.

11.11.2 Dry Powders

.1 **More to follow**

12.0 Additional advice on the packing dangerous goods

12.1 **General**

12.1.1 The advice of this section applies to cargo transport units in which dangerous goods are packed. It should be followed in addition to the advice given elsewhere in this Code of Practice.

12.1.2 International (and often national) transport of dangerous goods may be subject to several dangerous goods transport regulations, depending on the origin, final destination and the modes of transport used.

12.1.3 For intermodal transport, involving several modes of transport other than by sea, the rules and regulations applicable depend on whether it is a national movement or international transport or transport within a political or economic union or trading zone.

12.1.4 Transport of dangerous goods by road, rail or inland waterways may be subject to various regulations and agreements. Examples are:

- European Agreement concerning the International Carriage of Dangerous Goods by Road (ADR);
- Regulations concerning the International Carriage of Dangerous Goods by Rail (RID); and
- Title 49 of the Code of Federal Regulations of the United States.

12.1.5 Most national and international regulations are based on the United Nations Recommendations on the Transport of Dangerous Goods (Orange Book). However, national rules, applicable to domestic transport, may differ from international regulations.

12.1.6 For maritime transport, the provisions of the International Maritime Dangerous Goods Code (IMDG Code) apply. The IMDG Code provides detailed provisions on all aspects of the transport of packaged dangerous goods by sea.

12.1.7 Dangerous Goods are classified into hazard classes. Some of these are subdivided into divisions. All details are set forth in the applicable dangerous goods regulations as mentioned above. The shipper is responsible that packages with dangerous goods bear the appropriate labels and marks.

12.1.8 Under certain conditions, the dangerous goods regulations provide exemptions from some requirements if the dangerous goods are transported in "limited quantities" or excepted quantities". Further details are set forth in the applicable dangerous goods regulations.

12.2 **Before packing**

12.2.1 The IMDG Code and other international and national regulations require that the shipper provides transport information on each dangerous substance, material or article. This information shall include at least the following basic item:

- the UN Number;
- the Proper Shipping Name (including the technical name, as applicable);
- the class and/or division (and the compatibility group letter for goods of class 1);

- subsidiary risks when assigned;
- the packing group when assigned;
- the total quantity of dangerous goods (by volume or mass, and for explosives the net explosive content); and
- the number and kind of packages.

Other items of information may be required, depending on the mode of transport and the classification of the goods (e.g., flashpoint for transport by sea). The various items of information required under each regulation and applicable during intermodal transport operations should be provided so that appropriate documentation may be prepared for each shipment.

12.2.2 The shipper should also ensure that dangerous goods are classified, packaged, packed, marked, labelled, placarded and provided with the required signs, in accordance with the applicable regulations. A declaration by the shipper that this has been carried out is normally required. Such a declaration may be included with the required transport information.

12.2.3 The shipper should also ensure that the goods to be transported are authorized for transport by the modes to be used during the transport operation. For example, self-reacting substances and organic peroxides requiring temperature control are not authorized for transport by rail under the RID regime. Certain types of dangerous goods are not authorized to be transported on board passenger ships and therefore the requirements of the IMDG Code should be carefully studied.

12.2.4 Current versions of all applicable regulations should be easily accessible and referred to during packing to ensure compliance.

12.2.5 Dangerous goods should only be handled, packed and secured by trained personnel. Supervision by a responsible person who is familiar with the legal provisions, the risks involved and the measures that should be taken in an emergency is required.

12.2.6 Suitable measures to prevent fires should be taken, including the prohibition of smoking in the vicinity of dangerous goods.

12.2.7 Packages of dangerous goods should be examined and any found to be damaged, leaking or sifting should not be packed. Packages showing evidence of staining, etc., should not be packed without first determining that it is safe and acceptable to do so. Water, snow, ice or other matter adhering to packages should be removed before packing. Substances that have accumulated on drum heads should initially be treated with caution in case they are the result of leakage or sifting of contents. If pallets have been contaminated by spilt dangerous goods they should be destroyed by appropriate disposal methods to prevent use at a later date.

12.2.8 If dangerous goods are palletized or otherwise unitized they should be compacted so as to be regularly shaped, with approximately vertical sides and level at the top. They should be secured in a manner unlikely to damage the individual packages comprising the unit load. The materials used to bond a unit load together should be compatible with the substances unitized and retain their efficiency when exposed to moisture, extremes of temperature and sunlight.

12.2.9 An overpack and unit load should be marked with the Proper Shipping Name and the UN Number and marked and labelled, as required for packages, for each item of dangerous goods contained in the overpack or unit load unless markings and labels representative of all dangerous goods in the overpack or unit load are clearly visible. An overpack, in addition, should be marked with the word "OVERPACK" unless markings

and labels representatives of all dangerous goods as required for packages in to overpack are visible.

12.2.10 The stowage and method of securing of dangerous goods in a cargo transport unit should be planned before packing is commenced.

12.3 Packing

12.3.1 Special care should be taken during handling to avoid damage to packages. However, if a package containing dangerous goods is damaged during handling so that the contents leak out, the immediate area should be evacuated until the hazard potential can be assessed. The damaged package should not be shipped. It should be moved to a safe place in accordance with instructions given by a responsible person who is familiar with the risks involved and knows the measures that should be taken in an emergency.

12.3.2 If a leakage of dangerous goods presents safety or health hazards such as explosion, spontaneous combustion, poisoning or similar danger, personnel should immediately be moved to a safe place and the Emergency Response Organization notified.

12.3.3 Dangerous goods should not be packed in the same cargo transport unit with incompatible goods. In some instances even goods of the same class are incompatible with each other and should not be packed in the same unit, e.g., acids and alkalis of class 8. The requirements of the IMDG Code concerning the segregation of dangerous goods inside cargo transport units are usually more stringent than those for road and rail transport. Whenever an intermodal transport operation does not include transport by sea, compliance with the respective inland transport regulations may be sufficient. However, if there is any possibility that a part of the transport operation will be by sea, the segregation requirements of the IMDG Code should be strictly complied with.

12.3.4 When dangerous goods are being handled, smoking or the consumption of food and drink should be prohibited.

12.3.5 Packages marked with orientation arrows should be packed with the arrows pointing upwards. Vented packages should be packed in such a way that the vents will not be blocked.

12.3.6 Drums containing dangerous goods should always be stowed in an upright position unless otherwise authorized by the Competent Authority.

12.3.7 Dangerous goods consignments which form only part of the load of a cargo transport unit should, whenever possible, be packed adjacent to the doors with markings and labels visible. Particular attention is drawn to [3.3.1] concerning the securing of cargo by the doors of a unit.

12.3.8 The number of packages containing dangerous goods in excepted quantities in any cargo transport unit is limited to a maximum of 1,000.

13.0 On completion of packing

13.1 Closing the CTU

13.1.1 After closing the doors, it should be ensured that all closures are properly engaged and secured. If the doors of a cargo transport unit are locked, the means of locking shall be such that, in case of emergency, the doors can be opened without delay. Where cargo transport units have hinged or detachable fittings, a check should be made that they are properly secured, with no loose equipment likely to cause a hazard during transport.

~~13.1.2~~ Cargo transport units in international trade should be sealed with a seal bearing a unique identification number. Many countries require by national legislation that such seals shall meet the standard of ISO 17712:2010. ~~ISO 17712:2010 establishes uniform procedures for the classification, acceptance and withdrawal of acceptance of mechanical seals on freight containers, bulk railcars and truck trailers. It provides a single source of information on mechanical seals which are acceptable for securing cargo transport units in international commerce. The purpose of mechanical seals is, as part of a security system, to determine whether a cargo transport unit has been tampered with, i.e. whether there has been unauthorized entry into the cargo transport unit through its doors. Seals meeting the standard of ISO 17712:2010 shall comply with certain criteria for strength and durability so as to prevent accidental breakage, early deterioration (due to weather conditions, chemical action, etc.) or undetectable tampering under normal usage. [COMMENT: the current text is way too long for the purpose of the COP. Also, should this not be mentioned the first time there is a reference to sealing of CTUs upon completion of the loading process?]~~

~~13.1.3~~ 13.1.2 Where security devices, beacons or other tracking or monitoring equipment are used, they should be securely installed to the cargo transport unit and, when equipped with a source of energy, they should be of a certified safe type¹¹. It should be noted that the International Convention for the Safety of Life at Sea (SOLAS) requires that no sources of ignition shall be present in enclosed cargo spaces where highly flammable dangerous goods are stowed.

13.2 Marking and placarding

13.2.1 The applicable dangerous goods regulations require that placards (enlarged labels), marks and other signs are affixed to the surfaces of a cargo transport unit. The specifications of these placards, marks and signs and the locations where they have to be affixed are described in detail in the applicable dangerous goods regulations.

13.2.2 The applicable dangerous goods regulations may require specific warning signs for cargo transport units which contain solid carbon dioxide (CO₂ – dry ice) or other expendable refrigerant used for cooling purposes. The sign aims to warn of the possibility of an asphyxiating atmosphere.

13.2.3 The applicable dangerous goods regulations may require specific warning signs for cargo transport units under fumigation. The details of marking and further instructions for the handling of such cargo transport units are set forth in the applicable dangerous goods regulations.

13.3 Documentation

13.3.1 The packer of the cargo transport unit should inform the shipper ~~or those responsible to contract the shipment with the carrier~~ on the identification number of the cargo transport unit (container number or vehicle number as appropriate) and on the identification number of the seal, thus to ensure that these identification numbers are included in the shipping documentation that the shipper provides to the carrier for inclusion in carrier issued ~~all~~ transport documents, such as bill of lading, way bills, consignment notes or cargo manifests.

13.3.2 In addition, whenever dangerous goods are packed into a cargo transport unit the IMDG Code and other transport regulations require that those responsible for the packing of the cargo transport unit shall provide a “container/vehicle packing certificate”

¹¹ Refer to the Recommendations published by the International Electrotechnical Commission, in particular, to publications IEC 60079 and IEC 60092.

specifying the identification number of the container or the vehicle and certifying that the packing operation was carried out in accordance with the requirements of the applicable dangerous goods regulations. For all details of documentation, the relevant dangerous goods regulations shall be referred to.

13.3.3 Cargo transport units for which a packing certificate for dangerous goods is not required and which are intended to be loaded onto a ship in maritime trade should be provided with a “cargo stowage and securing declaration”, stating that the cargo in the cargo transport unit has been properly stowed and secured for the intended sea voyage. This declaration, issued by the shipper, should state:

Formatted: Highlight

Formatted: Highlight

- the identification number of the cargo transport unit;
- the place and date of loading;
- a short description of the commodity(ies);
- the wording “I hereby declare that the cargo in the above-mentioned cargo transport unit has been properly stowed and secured for transport by sea, taking into account the Code of Practice for packing of cargo in transport units”;
- the name of signatory;
- place and date; and
- signature on behalf of the packer of the shipper.

Formatted: Highlight

13.3.4 The “container/vehicle packing certificate” mentioned in 11.3.2 is a mandatory document for dangerous goods under SOLAS chapter VII regulation 4. For other cargoes not meeting the definition of dangerous goods in SOLAS chapter VII, the provisions of SOLAS chapter VI regulation 5 apply, where it is required that cargo and cargo units shall be so packed and secured within a cargo transport unit as to prevent, throughout the sea voyage, damage or hazard to the ship and persons on board. The “cargo stowage and securing declaration” mentioned in 11.3.3 is not a mandatory document under SOLAS convention. Such declaration is recommended in chapter 2 of the Code of Safe Practice for Cargo Stowage and Securing of the International Maritime Organization, only when road vehicles are used as cargo transport units. However, individual carriers might require this declaration from shippers to provide evidence that the packer of a cargo transport unit complied with the requirements of SOLAS Chapter VI regulation 5.

[COMMENT: This needs further discussion and consideration. First, as mentioned earlier, the carrier’s contractual relationship is with the shipper, not with the packer, so any declaration intended for the carrier should be issued by the shipper. Next, how would such a declaration relate to the earlier discussed certified weight ticket? Third, how would such a declaration relate to the earlier discussed Accredited Packer concept? Fourth, we need to ensure that this COP does not turn into a template for untold numbers of certificates and declarations whose purpose and use and status are not clearly defined, and whose authenticity cannot be established. In this regard, consideration also needs to be given to the fact that as long as e.g. the declaration mentioned above is not mandatory and be made a condition for stowage aboard ship, at least some CTUs will be presented for stowage onboard ship without such declarations. What should happen then?]

Formatted: Not Highlight

Formatted: Not Highlight

Formatted: Not Highlight

Formatted: Not Highlight

Formatted: Not Highlight

Formatted: Not Highlight

Formatted: Not Highlight

13.3.413.3.5 Final checks

.1 **More to follow**

13.3.513.3.6 Fitting seals

.1 **More to follow**

13.4 Marking

.1 **More to follow**

13.5 Documentation

13.5.1 Customs and security

13.5.2 Dangerous Goods

13.5.3 Other cargoes

To be discussed

14.0 Basic principles for the safe handling and securing of CTUs

14.1 General

14.1.1 **More to follow**

14.2 Lifting

14.2.1 The different designs of cargo transport units permit different lifting techniques, some of which are not generally associated with intermodal transport. This section will exclude those lifting techniques that are associated with recovery and / or maintenance.

14.2.2 In this section the term lifting is used to move the cargo transport unit from one mode to another or one mode to or from the ground.

14.2.3 Road vehicles

There are two methods for intermodal movement of road vehicles:

.1 Roll on / roll off (RO-RO).

Rigid road vehicles can be driven onto ferries and onto special rail wagons.

.2 Lift on / Lift off (LO-LO)

14.2.4 Rail wagons

Rail wagons are designed that the wagon rests onto the bogies and lifting a wagon vertically could result in the wagon and bogies becoming detached. Therefore the Packing Code does not consider this method.

Rail companies developed a system where a box wagon fitted with lifting rings could be lifted between rail wagons, flat bed road vehicles and the ground. Such a system has been replaced by the intermodal containers and lifting for these units will be covered in paragraph 14.2.6.

Rail wagons may be however may be shunted onto special train ferries deck(s) equipped with rail tracks.

There are a number of examples of train ferries across the world, for example between Varna and Odessa in Bulgaria, Rostock (Germany) and Trelleborg (Sweden) and across the Cook Strait (New Zealand).

These routes can generate different sea conditions and therefore three important aspects must be considered:

- .1 Rail wagons will have a high centre of gravity which may reduce the stability of the ferry;
- .2 Rail wagons need to be properly secured to prevent their movement; and
- .3 Cargoes carried within cargo transport units need to be secured and cargoes such as bulk liquids notified so that the ferry operator can accommodate such cargoes.

14.2.5 Inland waterway vessels

In the 1950s a system was developed to satisfy the needs of cargo transport customers, as the method employed at that time was considered as inefficient. The Lighter Aboard Ship (LASH) was developed where barges (or lighters) can be lifted aboard a larger vessel. Unpowered lighters could then be transported via the open seas to other inland waterway system.

Although this system is still used on the Rhine and in the US this system and may be used to carry intermodal transport units, it is considered that this system is outside of the scope of the Packing Code.

14.2.6 Intermodal containers

Intermodal (ISO and Swapbody) containers have been designed for handling by a multitude of different devices. Some are suitable for lifting loaded units, while others are only be used for empty handling.

The International Standard 3874 identifies a number of suitable lifting methods which are discussed below:

.1 Top lift spreader

The container is lifted by means of a spreader designed to lift containers by the top apertures of the four top corner fittings. The lifting force shall be vertical.

Where there is not a suitable spreader that can be attached directly to the top corner fittings slings can be used so long as the lifting force remains vertical.

This method can be used for all container sizes fitted with top corner fittings, in an empty or loaded state.

.2 Top lift sling

The container is lifted by all four top corner fittings with forces applied other than vertically.

The angle between the container roof and the slings should be greater than 30°.

This method can be used for all sizes of container with a structural top rail in an empty state. This method must not be used for loaded containers or flatrack containers (fixed or folding end erected)

.3 Bottom lift sling

The container is lifted from the side apertures of four bottom corner fittings by means of slings.

The angle between the container base and the slings should be greater than 30° and should bear on the corner fittings only.

This method can be used for all container sizes, in an empty or loaded state.

.4 Side lift, bottom lift

The container is lifted by means of a side lift frame designed to lift a container by the two bottom fittings of one side and to retain it by the two top corner fittings of the same side.

This method can be used on all sizes of containers with a full end frame and fitted with top corner fittings when in the empty state. At present only 20ft ISO containers can be lifted when loaded.

.5 Side lift, top lift

The container is lifted by means of a side lift frame designed to lift a container by the two top corner fittings of one side and to take the reaction forces on the bottom corner fittings off the same side or on suitable corner post areas above those corner fittings.

The lifting frame can use the top apertures with twistlock devices, or the side apertures and a pin device.

This method can be used on all sizes of containers with a full end frame and fitted with top corner fittings when in the empty state. At present only 20ft ISO containers can be lifted when loaded.

.6 Side lift, bottom rail

The container is lifted by means of a side lift frame designed to lift a container by the two top corner fittings of one side and to take the reaction forces at the bottom side rail of the same side by means of a pad of sufficient size and located so as to prevent deformation and damage to the container.

The lifting frame can use the top apertures with twistlock devices, or the side apertures and a pin device.

This method can be used on all sizes of containers with a full end frame and fitted with top corner fittings when in the empty state.

.7 End lift, bottom lift

The container is lifted by means of an end frame designed to lift a container by the two bottom corner fittings of one end and to restrain it by the two top corner fittings of the same end.

This method can only be used on 20ft general purpose, open top or non-pressurised dry bulk containers in an empty state.

.8 End lift, top lift

The container is lifted by means of an end lift frame designed to lift a container by the two top corner fittings of one end and to take reaction forces on the bottom corner fittings of the same end or on a suitable corner post areas above the corner fittings.

The lifting frame can use the top apertures with twistlock devices, or the side apertures and a pin device.

This method can only be used on 20ft general purpose, open top or non-pressurised dry bulk containers in an empty state.

.9 Fork lift

The container, if provided with fork pockets is lifted by means of forks.

The forks should, ideally, extend the whole width of the container, but under no circumstances should they extend less than 1,825 mm into the fork pockets.

This method can be used on 20ft containers in an empty or loaded state with the exception of tank, and pressurised bulk containers which should not be lifted by fork trucks at all.

Some 40ft and longer equipment (general purpose and flatrack) are fitted with fork pockets. If present, they may be used for empty lift only so long as the lifting equipment has sufficient width to ensure stability during movement.

Where there is no fork pockets the container should not be lifted in any state.

Attempting to lift containers by other means should not be attempted as the design of the container is not capable of withstanding the forces and stress involved. For example attempting to lift a container using a fork truck at each end of the container may result in damage to the bottom front and rear sills and, since the container is not totally stable, could fall from the forks, further damaging the container, its contents and cause injuries to drivers and personnel nearby,

- 14.3 CTUs on the ground
- 14.4 Handling CTUs
- 14.5 CTUs on vehicles
- 14.6 CTUs on rail wagons
- 14.7 CTUs on Ships
- 15.0 In shipment cargo inspections
- 16.0 Advice on receipt and unpacking of CTUs
 - 16.1 Opening CTUs
 - 16.1.1
 - 16.2 Unpacking
 - 16.3 Cleaning
 - 16.4 Environmental disposal of dunnage
 - 16.5 Reporting
- 17.0 CTU deficiencies
 - 17.1 CTU structural deficiencies
 - 17.2 Packing deficiencies
 - 17.3 Load deficiencies

- 17.4 Consequences of deficiencies
- 17.5 Insurance
- 18.0 Training in packing of cargo in CTUs
 - 18.1 Regulatory authorities
 - 18.2 Management
 - 18.3 Personnel
 - 18.4 Training
 - 18.5 Recommended course syllabus – overview

1.0 Acronym

ACRONYM	Full Title
3PL	Third Party Logistics
AA	Always Afloat
AAPA	American Association of Port Authorities
AAR	Association of American Railroads
AAR	Against All Risks (insurance clause)
ABC	Activity Based Costing
ABI	Automated Broker Interface
ACE	Automated Commercial Environment system
ACEP	Approved continuous examination programme
ADR	European Agreement concerning the International Carriage of Dangerous Goods by Road
AEI	Automatic electronic identification
AI	All Inclusive.
AID	Agency for International Development.
AIS	Automated Identification System
AMSA	Australian Marine Safety Authority
ANOA	Advanced Notice of Arrival
ANSI	American National Standards Institution
AQ	Air Quality
AQI	Agriculture Quarantine Inspection.
ASC	Automated Commercial Systems
ASEAN	Association of South East Asian Nations
ATA.	American Trucking Association.
ATD	Artificial Tween Deck
ATDNSHINC	Any time Day or Night Sundays & Holidays Included.
AWWL	Always within Institute Warranties Limits
B/L	Bill of Lading
BAF	Bunker Adjustment Factor
BB	Ballast Bonus
BB	Bare Boat
BBL	Barrel
BCO	Beneficial Cargo Owner
BIC	Bureau International des Conteneurs et du Transport Intermodal.
BIFA	British International freight Association
BIMCO	Baltic and International Maritime Council
Bls	Bales

BLU	CoP for Safe Loading & Unloading of Bulk Carriers
BP	Safety Briefing Pamphlet
BSI	British Standards Institute
C&F	Cost and Freight
CAD	Cash Against Documents
CAF	Cost, Assurance and Freight.
CAF	Currency Adjustment Factor.
CBM	Cubic Metre
CCC	International Customs Convention for Containers (1972)
CCNR	Central Commission for the Navigation of the Rhine
CDI-mpc	Chemical Distribution Institute – Marine Packed Cargo
CE	Consumption Entry
CEFIC	Conseil Européen des Federations de l'Industrie Chimique (European Trade Association for Chemicals)
CEN	European Committee for Standardization (Comité Européen de Normalisation)
CFD	Continuous Flow Distribution
CFR	Cost and Freight
CFS	Container Freight Station
CG	Correspondence Group
CGPM	Comité International des Poids et Mesures (General Conference on Weights and Measures)
CI	Cost and Insurance
CIA	Chemical Industries Association
CIA	Cash in Advance
CIF	Cost, Insurance and Freight.
CIF&C	Price includes commission as well as CIF.
CIF&E	Cost, Insurance, Freight and Exchange.
CIFCI	Cost, Insurance, Freight, Collection and Interest.
CIFI&E	Cost, Insurance, Freight, Interest and Exchange.
CIM	International Convention concerning the Carriage of Goods by Rail
CIP	Carriage and Insurance Paid.
CIRIA	The Construction Industry Research and Information Association
CKD	Completely Knocked Down
CL	Carload” or Container load
CLECAT	European Association for Forwarding, Transport, Logistics and Customs Services
CM	Cubic Meter
cm	Centimeter
CMPH	Gross Crane Moves per Hour
CMR	Convention on the Contract for the International Carriage of Goods by Road

COA	Container Owners Association
COD	Collect on Delivery
COD	Carried on Docket (pricing).
COFC	Container On Flat Car.
CofG	Centre of Gravity
COGSA	Carriage of Goods by Sea Act
COP	Code of Practice
COP	Customs of the Port
COU	Clip on Unit
CPC	Certificate of Professional Competence
CPD	Carnet de Passage en Douane
CPT	Carriage Paid To.
CRP	Continuous Replenishment Program
CSC	International Convention for Safe Containers (CSC) 1972
CSI	Container Security Initiative
CSL	Container Stuffing List
C-TPAT	Customs Trade Partnership Against Terrorism.
CTU	Cargo Transport Unit
Cu	Cubic
CWO	Cash with Order
cwt	Hundred weight (mass)
CWT	Deadweight Tonnage
CY	Container Yard
D&H	Dangerous and Hazardous cargo.
D/A	Documents against Acceptance
D/P	Document against Payment
DBA	Doing Business as
DDC	Destination Delivery Charge
DDP	Delivery Duty Paid.
DDU	Delivery Duty Unpaid.
DE	Ship Design & Equipment Sub-Committee (IMO)
DEMDES	Demurrage/Despatch money
DEQ	Delivery Ex Quay.
DES	Delivered Ex Ship.
DG	Drafting Group
DG MOVE	European Commission's Directorate-General for Mobility and Transport
DG VII	Directorate/General VII Transport
DIS	Draft International Standard
DIT	Destination Interchange Terminal
DMT	Destination Motor terminal

Formatted: Danish

DnV	Det Norske Veritas
DOL	Department of Labour
DOT	U.S. Department of Transportation
DSC	Dangerous Goods Solid Cargoes and Containers Sub-Committee (IMO)
DSU	Delay in Start Up
DWT	Deadweight Tonnage.
E&T	Editorial and Technical Group
ECE	Economic Commission for Europe (see also UN ECE)
ECH	Empty container handler
ECMC	U.S. Exporters Competitive Maritime Council.
ECMCA	Eastern Central Motor Carriers Association.
ECOSOC	Economic and Social Council (UN Agency)
EDI	Electronic Data Interchange.
EFFA	European Freight Forwarders' Association
EFIPA	European Federation of Inland Ports Association
EFT	Electronic Funds Transfer
EIA	European Intermodal Association
EIR	Equipment Interchange Receipt
EMSA	European Maritime Safety Agency
ESA	European Agency for Safety and Health at Work
ESC	European Shippers' Council
ESCAP	Economic and Social Commission for Asia and the Pacific (UN Agency)
ESPO	European Sea Ports Organization
ETA	Estimated Time of Arrival.
ETA	Estimated Time of Availability
ETD	Estimated Time of Departure.
ETR	Estimated Time of Readiness
ETS	Estimated Time of Sailing
EU	European Union
EVA	Economic Value Added
EWIB	Eastern Weighing and Inspection Bureau.
EXW	Ex-works
FAF	Fuel Adjustment Factor, see also BAF
FAK	Freight All Kinds
FAL	Facilitation Committee (IMO)
FAS	Free Along Side
FAS	Free Alongside Ship.
FAT	Fully automated twistlock
FCA	Free Carrier
FCC	Flexitank / Container Combination

FCL	Full container load
FD	Free Discharge.
FDA	Food and Drug Administration.
FDIS	Final Draft International Standard
FEPORT	Federation of European Private Port Operators
FEU	Forty-foot Equivalent Unit
FFE	Forty-Foot Equivalent unit
FIATA	International Federation of Freight Forwarders Associations
FIFO	First In, First Out
FIFO	Free In – Free Out see FIO
FIO	Free In and Out
FMC	Federal Maritime Commissions
FMCSA	Federal Motor Carrier Safety Administration
FO	Free Out
FOB	Free On Board
FOR	Free on Rail.
FPA	Free of Particular Average.
FPPI	Foreign Principal Party of Interest.
FTA	Freight Transport Association
GATT	General Agreement on Tariffs and Trade.
GBL	Government Bill of Lading.
GDSM	General Department Store Merchandise.
GMPH	Gross Moves per Hour
GO	General Order
GOH	Garment on Hanger
GP	General Purpose
GRI	General Rate Increase
GSF	Global Shippers' Forum
GT	Gross Tonnage
GVW	Gross Vehicle Weight
HNS	Hazardous and Noxious Substances Convention
HS	Harmonized System of Codes
HSE	Health and Safety Executive
I.T.	In-Transit Entry
IA	Independent Action
IACS	International Association of Classification Societies
IAEA	International Atomic Energy Authority
IAPH	International Association of Ports and Harbours
IATA	International Air Transport Association
IBC	Intermediate Bulk Container

IBC	See BIC
IBTA	International Bulk Terminals Association
ICAO	International Civil Aviation Organisation
ICC	International Chamber of Commerce
ICC	Interstate Commerce Commission (US)
ICGB	International Cargo Gear Bureau, Inc.
ICHCA	ICHCA International Limited
ICS	International Chamber of Shipping
IE	Immediate Exit
IFA	International Freight Association
IFCOR	International Intermodal Freight Container Reporting Organisation
IFM	Inward Foreign Manifest
IFPTA	International Forest Products Transport Association
IHMA	International Harbour Masters Association
IICL	Institute of International Container Lessors
IIMS	International Institute of Marine Surveyors
IISPCG	Inter Industry Shipping & Ports Contact Group
ILA	International Longshoremen's Association
ILO	International Labour Organisation
ILWU	International Longshoremen's and Warehousemen's Union
IMC	Intermodal Marketing Company
IMCO	International Maritime Control Organisation. See IMO.
IMDG	International Maritime Dangerous Goods
IMMTA	International MultiModal Transport Association
IMO	International Maritime Organisation. Formally IMCO.
IOSH	Institute of Occupational Safety and Health
IPI	Inland Point Intermodal
IRU	International Road Transport Union
ISA	Information System Agreement
ISO	International Organization for Standardization
ISP	International Safety Panel of ICHCA
ISPS	International Ship and Port Facility Security Code
ISTDG	International Symposium on the Transport of Dangerous Goods by Sea and Inland Waterways
IT	Immediate Transport
IT	Information Technology
IT Entry	Immediate Transportation Entry
ITCO	International Tank Container Owners Association
ITF	International Transport Workers' Federation
ITF	International Transport Forum
ITIGG	International Transport Implementation Guidelines Group.

IUMI	International Union of Marine Insurers
JIT	Just in Time
JOC	Journal of Commerce
KD	Knocked Down
KT	Kilo tonne
L/C	Letter of Credit.
LASH	Lighter Aboard Ship.
lbs	Pounds (mass)
LC	Letter of Credit
LCL	Less than a container load
LIFO	Last In First Out
LNG	Liquefied natural Gas
LOLO	Lift on Lift Off
LR	Lloyds Registry
LT	Long Ton
LTL	Less than Trailer Load
MAIIF	Marine Accident Investigators' International Forum
MARPOL 73/78	International Convention for the Prevention of Pollution from Ships 1973, as modified by the Protocol of 1978
MCA	Maritime and Coastguard Agency (UK)
MCFS	Master Container Freight Station. (see CFS)
MDA	Maritime Domain Awareness
MEPC	Marine Environment Protection Committee
MGM	Maximum Gross Mass
MLB	Mini Land Bridge
MMFB	Middlewest Motor Freight Bureau (US)
MOU	Memorandum of Understanding
MSA	Maritime Security Act.
MSC	Maritime Safety Committee (IMO)
MSL	Maximum securing load
MSSIS	Maritime Security and Safety Information System
MT	Metric Ton
MTO	Multimodal Transport Operator
MTSA	US Maritime Transportation Security Act 2002
NCB	National Cargo Bureau Inc
NCITD	National Committee on International Trade Documentation.
NEC	Not Elsewhere Classified.
NES	Not Elsewhere Specified.
NI	Nautical Institute
NMFC	National Motor Freight Classification.
NMPH	Net Moves per Hour

NMSA	National Maritime Safety Association
NOE	Not Otherwise Enumerated
NOI	Not Otherwise Indexed.
NOIBN	Not Otherwise Indexed By Name.
NOR	Notice of Readiness (when the ship is ready to load.)
NOS	Not Otherwise Stated.
NOS	Not Otherwise Specified.
NPC	National Ports Council
NSC	National Safety Council
NT	Net Tonnage
NVOCC	Non Vessel Owning Common Carrier
O/N	Order-Notify
OBL	Original Bill of Lading
OCIMF	Oil Companies International Marine Forum
OCP	Overland Common Port
OCP	Overland Common Points.
ODS	Operating Differential Subsidy.
OECD	Organization of Economic Cooperation and Development
OGMSA	Office of Global Maritime Situational Awareness
OMT	Origin Motor Terminal
OOG	Out of Gauge
OPIC	Overseas Private Investment Corporation,
ORFS	Origin Rail Freight Station.
ORT	Origin Rail Terminal
OS&D	Over, Short or Damaged
OSHA	Occupational Safety and Health Administration
P	Payload
P&I	Protection and Indemnity,
PADAG	Please Authorize Delivery Against Guarantee.
PAG	Polyalkylene Glycol
PAS	Publicly Available Specification
PDG	Packaged Dangerous Goods
PDP	Port workers Development Programme
PEMA	Port Equipment Manufacturers Association
POD	Port of Discharge.
POD	Port of Destination.
POD	Proof of Delivery
POE	Polyolester oil
POL	Port of Loading.
POL	Petroleum, Oil, and Lubricants.

PPI	Principal Party of Interest (see USPPPI and FPPI).
PSGP	Port Security Grant Program
PTI	Pre-Trip Inspection
PTSC	Port & Terminal Service Charge
QR	Quick Response
R	Rating (Maximum Gross Mass)
RFP	Request for Proposal
RFQ	Request for quotation.
RHA	Road Haulage Association
RID	Regulations concerning the International Carriage of Dangerous Goods by Rail
ROLA	Roll on Roll off Trains
RO-RO	Roll on- Roll Off
RP	Research Paper
RT	Revenue Ton
RVNX	Released Value Not Exceeding
S/D	Sight Draft
S/D	Sea Damage
SATLs	Semi Automatic Twistlocks
SC	Sub Committee
SCAC	Standard Carrier Abbreviation Code
SED	Shipper's Export Declaration
SFI	Secure Freight Initiative
SHEX	Saturday and Holidays Excluded.
SHINC	Saturday and Holidays Included.
SIC	Standard Industrial Classification
SIGTTO	Society for International Gas Tanker & Terminal Operations Limited
SITC	Standard International Trade Classification
SKU	Stock Keeping Unit
SL&C	Shipper's Load & Count
SL/W	Shippers load and count
SOLAS	International Convention for the Safety of Life at Sea (SOLAS), 1974
SPA	Subject to Particular Average
SPI	Ship Port Interface
SS	Steamship.
SSHEX	Saturdays, Sundays and Holidays Excepted
ST	Short Ton
STB	Surface Transportation Board
STC	Said to Contain.
STCC	Standard Transportation Commodity Code
STW	Said to weigh.

SWIFT	Society for Worldwide Interbank Financial Telecommunication
SWL	Safe Working Load
T	Tare
T&E	Transportation and Exportation.
T&E	Transportation and Exit
TBN	To Be Nominated (when the name of a ship is still unknown).
TC104	International Standards Organization Technical Committee 104 –freight containers
TEU	Twenty-foot Equivalent Unit
THC	Terminal Handling Charge
TIR	Transport Internationaux Routiers System
TL	Trailer Load
TOA	Technical and Operational Advice document
TOFC	Trailer on Flat Car Rail
TOS	Terms of Sale (i.e. FOB/CIF/FAS).
TRC	Terminal Receiving Charge
TREMCARD	Transport Emergency Card issued by CEFIC (Intended to comply with the “instructions in writing” requirements in certain road transport regulations, eg: ADR)
TSR	Top Side Rail
TT Club	Through Transport Mutual Insurance Association Limited
TWIC	Transportation Worker Identification Credential
UCP	Uniform Customs and Practice for Documentary Credits
UFC	Uniform Freight Classification
UIC	Union Internationale de Chemins de Fers
UIRR	Union Internationale des Societes de Transport Combine Rail-Route
ULCC	Ultra Large Crude Carrier
UN	United Nations
UN ECE	United Nations Economic Commission for Europe
UNCTAD	United Nations Commission for Trade and Development
UNEP	United Nations Environment Programme
UNISTOCK	European Federation of Silo Operators
UPC	Universal Product Code
USCG	United States Coastguard
USPPI	United States Principal Party of Interest
UTITI	University of Toledo Intermodal Transportation Institute
VISA	Voluntary Intermodal Sealift Agreement
VLFO	Vessel Load Free Out
VSA	Vessel Sharing Agreement
VSIE	Vessel Supplies for Immediate Exportation
VTL	Vertical Tandem Lifting

W/B	Waybill
W/M	Weight or Measurement
WCO	World Customs Organisation
WDEX	Warehouse Withdrawal for Transportation Immediate Exportation
WDT	Warehouse Withdrawal for Transportation
WDT&E	Warehouse Withdrawal for Transportation Exportation
WG	Working Group
WHO	World Health Organization
WIBON	Whether In Berth or Not.
WMU	World Maritime University
WP.15	UN ECE Working Party on the Transport of Dangerous goods (deals with ADR)
WP.24	UN ECE Working Party on Intermodal Transport and Logistics
WPA	With Particular Average.
WSC	World Shipping Council
WTL	Western Truck Lines.
WWD	Weather Working Days.
YTD	Year to date
Zn	Abbreviation for: Azimuth

2.0 Definitions **Separate file – to follow**

- 2.1 Packing terms
- 2.2 Shipping Terms
- 2.3 CTU Terms

3.0 CTU types

3.1 ISO Containers

3.1.1 Containers – General

- .1 A container¹² (freight container) is an article of transport equipment which is:
 - 3.1.1.1.1 of a permanent character and accordingly strong enough to be suitable for repeated use;
 - 3.1.1.1.2 specially designed to facilitate the carriage of goods by one or more modes of transport, without intermediate reloading;
 - 3.1.1.1.3 fitted with devices permitting its ready handling, particularly its transfer from one mode of transport to another;
 - 3.1.1.1.4 so designed as to be easy to pack and unpack;
 - 3.1.1.1.5 having an internal volume of at least 1 m³ (35,3 ft³)
- .2 A container is further defined by the International convention for safe containers¹³:
 - 3.1.1.2.1 designed to be secured and / or readily handled, having corner fittings for these purposes
 - 3.1.1.2.2 of a size such that the area enclosed by the four outer bottom corners is either:
 - at least 14 m² (150 ft²) or
 - at least 7 m² (75 ft²) if it is fitted with top corner fittings.

¹² ISO 830:1999 Freight containers - vocabulary

¹³ The international convention for safe containers (CSC), 1972 as amended, IMO.

In addition to the standard lengths there are regional / domestic variations which include 48ft, 53ft and longer.

The standard width is 8ft (2,438mm), with regional variations of 8ft 6in (USA) and 2.5m.

The ISO standard heights are half height (4ft 3in / 1,295mm), 8ft (2,438mm), 8ft 6in (2,591mm) and 9ft 6in (2,896mm).

3.1.1.5.1 There are very few 8ft high containers left in circulation

3.1.1.5.2 Practically all the 20ft long containers are 8ft 6in high

3.1.1.5.3 Practically all of the 45ft long containers are 9ft 6in high

3.1.1.5.4 Regional heights of 9ft, 10ft and 3m can be found for specific cargoes.

.6 Fork-lift pockets

3.1.1.6.1 May be provided on 20ft and 10ft containers

3.1.1.6.2 Are not generally fitted on 30ft and longer containers.

3.1.1.6.3 On 20ft are generally fitted with 2,050mm \pm 50mm and may be used for lifting full containers. Some 20ft containers may have a second set at 900 mm centres which are used for emptying lifting. However this design feature is now almost extinct.

3.1.2 General Purpose Containers

.1 A general purpose container (also known as a GP or dry van) is a container which is totally enclosed and weather-proof. It generally will have a corten steel frame with a rigid roof, rigid side walls, rigid end walls at least one of which is equipped with doors, and a floor. It is intended to be suitable for the transport of cargo in the greatest possible variety.

It is not intended for the carriage of a particular category of cargo, such as cargo requiring temperature control, a liquid or gas cargo, dry solids in bulk, cars or livestock or for use in air mode transport.

The GP container is by far the largest container type in the intermodal fleet comprising 89.7% of the ISO series I (maritime) fleet (see Annex 3 - 1). The 20ft x 8ft 6in GP container is the largest single container type forming just under half of the GP



Annex 3 - 3
fleet and about 41% of all container types and sizes.

World General Purpose Containers			
		Containers	Share
20ft	(8ft 6in)	7,447,088	48.2%
20ft	(9ft 6in)	10,811	0.1%
40ft	(8ft 6in)	2,901,355	18.8%
40ft	(9ft 6in)	4,920,639	31.8%
45ft	(9ft 6in)	183,504	1.2%
Others		1,975	0.0%
Total		15,465,372	

Annex 3 - 4

Source 2009

GP containers generally have passive ventilation, provided by two high level vents mounted on the side walls and have a ISO Type code G1.

2 Typical cargoes

The 20ft long GP container provides the most flexible of all the container types and sizes as it is capable of carrying denser materials and is often used to carry granite, slate and marble blocks.

The GP container is used for such cargoes as dairy and other "clean" products which require the interior to be "as new" without corrosion and flaking paint. At the other end of the spectrum, the GP container may be used for corrosive materials, such as wet salted hides. It is important that consignors advise the container supplier of the cargo prior to its delivery so that the correct standard of container can be delivered.

Packages can be loaded by hand and stacked across the container, lifted in using a counterbalance or pallet truck, or slid in on skids or slip sheets. When loading using a counterbalance truck, it is important that the axles load does not exceed that maximum permitted and that the cargo is distributed evenly.

GP containers are also used to transport cars and small vans either driven and secured to the floor, or secured to specialist racking that can be fitted and removed from the container without any modifications.

The GP container is also becoming a major transporter of bulk powders, granules and liquids, within dry liner bags or



Annex 3 - 6



Annex 3 - 5

flexitanks.



Annex 3 - 7



.3 Dimensions and volume

3.1.2.3.1 There are very few 20ft long x 9ft 6in high GP containers

3.1.2.3.2 There are very few 30ft long GP containers, this length can be considered as obsolete and not available.

3.1.2.3.3 There are very few 45ft long GP container that are not 9ft 6in high. GP containers with lower heights can be considered as unavailable.

.4 Minimum internal dimensions and volume

ISO Freight container internal dimensions												
Freight container description	Freight container designation	Length, L			Width, W			Height, H			Volume, V	
		mm	ft	in	mm	ft	in	mm	ft	in	m ³	ft ³
45ft long x 9ft 6in high	1EEE	13,522	44	4 ¾	2,330	7	7 ¾	2,655.0	8	9 ½	83.6	3,068
45ft long x 8ft 6in high	1EE							2,350.0	7	9 ½	74.0	2,719
40ft long x 9ft 6in high	1AAA	11,998	39	4 ¾	2,330	7	7 ¾	2,655.0	8	9 ½	74.2	3,043
40ft long x 8ft 6in high	1AA							2,350.0	7	9 ½	65.7	2,697
40ft long x 8ft high	1A							2,197.0	7	2 ½	61.4	2,495
40ft long half height	1AX							1,054.0	3	6 ½	29.5	1,236
30ft long x 9ft 6in high	1BBB	8,931	29	3 ¾	2,330	7	7 ¾	2,655.0	8	9 ½	55.2	2,007
30ft long x 8ft 6in high	1BB							2,350.0	7	9 ½	48.9	1,779
30ft long x 8ft high	1B							2,197.0	7	2 ½	45.7	1,646
30ft long half height	1BX							1,054.0	3	6 ½	21.9	809
20ft long x 9ft 6in high	1AAA	5,867	19	3	2,330	7	7 ¾	2,655.0	8	9 ½	36.3	1,220
20ft long x 8ft 6in high	1AA							2,350.0	7	9 ½	32.1	1,081
20ft long x 8ft high	1A							2,197.0	7	2 ½	30.0	1,000
20ft long half height	1AX							1,054.0	3	6 ½	14.4	491
10ft long x 8ft high	1A	2,802	9	2 ⁵ / ₁₆	2,330	7	7 ¾	2,197.0	7	2 ½	14.3	235
10ft long half height	1AX							1,054.0	3	6 ½	6.9	115

Annex 3 - 8

.5 Minimum door openings

3.1.2.5.1 9ft 6in high – 2,585 mm high x 2,330 mm wide.

3.1.2.5.2 8ft 6 in high – 2,280 mm high x 2,330 mm wide

3.1.2.5.3 8ft high – 2,136 x 2,330 mm wide

.6 Rating and load distribution

3.1.2.6.1 20ft long GP containers generally have a maximum gross mass greater than 30,000kg. The ISO standard was 30,480 kg, but this has been increased to 32,500 kg.

3.1.2.6.2 40ft and 45ft GP containers generally have a maximum gross mass of 32,500kg or 34,000kg

3.1.2.6.3 Loads should be distributed across the flooring:

Length	Mass (tonnes) per linear m			Mass (kg) per m ²		
	30480	32500	34000	30480	32500	34000
45ft	2.25	2.40	2.51	967	1,032	1,079
40ft	2.54	2.71	2.83	1,090	1,163	1,216
20ft	5.20	5.54	5.80	2,230	2,377	2,487

Annex 3 - 9

.7 Variations

There are few variations to the basic GP container, some 40ft GP containers are built with a door at each end. The example shown in Annex 3 - 10 shows the doors above the gooseneck tunnel and fork pockets for handling when empty.



Annex 3 - 10

Another variant to the general purpose container is the pallet-wide container. These units have end frames that comply with the requirements of the series 1 ISO freight container, but can accommodate two 1,200 mm wide pallets across the width of the container. This is achieved through a two designs where the side walls are thinner and moved outside of the ISO envelope.

3.1.3

Closed vented or ventilated containers:

- .1 A closed vented or ventilated container is a closed type of container similar to a general purpose container but designed to allow air exchange between its interior and the outside atmosphere. It will be totally enclosed and weatherproof, having a rigid roof, rigid side walls, rigid end walls and a floor, at least one of its end walls equipped with doors and that has devices for ventilation, either natural or mechanical (forced)



Annex 3 - 11

Vented containers are containers that have passive vents at the upper part of their cargo space. While most containers built now are fitted with two or more vents fitted in the front or side walls, ventilated containers are containers which have a ventilating system designed to accelerate and increase the natural convection of the atmosphere within the container as uniformly as possible, either by non-mechanical vents at both the upper and lower parts of their cargo space, or by internal or external mechanical means.

This is a very specialised piece of equipment and was quite popular in the 1990's with in excess of 5,000 in service. In 2012 the exact numbers is of these and forced ventilated containers are not known.

The type codes for the simplest forms of these containers are:

3.1.3.1.1 V0 for those specifically designed for carriage of cargo where natural ventilation is required, and

3.1.3.1.2 V2 for those having mechanical ventilation.

- .2 Typical cargoes

Ventilated containers were developed to carry green coffee beans and other agricultural products. Produce such as melons, oranges, potatoes, sweet potatoes, yams and onions are sometimes carried in ventilated containers.

- .3 Dimensions and volume

All ventilated containers are 20ft long and 8ft 6in high.

.4 Minimum internal dimensions and volume

Similar to the 20ft GP Container

.5 Minimum door openings

Similar to the 8ft 6in high GP containers

.6 Rating and load distribution

The latest production of ventilated containers was built with a maximum gross mass of 30,480kg.

.7 Variations

Most ventilated containers have ventilation grills built into the top and bottom side rails and the front top rail and bottom sill. To further improve the movement of air through the container an electrical fan can be mounted in the door end and connected up to shore and ships' supply. After the cargo has been delivered the fan can be removed and the fan hatch closed so that the container can be used as a GP container. These units are referred to as Fantainers.

3.1.4 Bulk and bulk capable:

.1 Within this type of container, there are a number of variations available. The definition of a non-pressurised dry bulk container is:

"Container for the transport of dry solids, capable of withstanding the loads resulting from filling, transport motions and discharging of non-packaged dry bulk solids, having filling and discharge apertures and fittings and complying with ISO 1496 part 4¹⁴."

Within that standard two sub types are described:

"Box type – dry bulk non-pressurised container for tipping discharge having a parallelepiped¹⁵ cargo space and a door opening at least at one end, which therefore may be used as a general purpose freight container."

"Hopper type – dry bulk non-pressurised container for horizontal discharge having no door opening, which therefore may not be used as a general purpose freight container."

Many owners needing a box type dry bulk container have built general purpose containers with bulk capabilities. These are constructed to meet the requirements of ISO 1496/1¹⁶. The difference between the two standards is the strength of the front and rear walls. In ISO 1496 part 4 the walls are to be tested to a minimum of 0.6 of the payload, whereas part 1 only requires 0.4 of payload.

Loading hatches are generally round, 600 mm in diameter varying in number from one centrally up to six along the centre line.

Discharge hatches come in a number of forms:

Full width "letterbox" type either in the front wall or in the rear as part of the door structure or "cat flap" type hatches fitted into the rear doors.

In some box type dry bulk containers with full width discharge hatches in the rear (door) end, the hatch can be incorporated



Annex 3 - 12



into the left hand door, as shown in Annex 3 - 12, or as shown in the central picture of Annex 3 - 13, access is gained to the

Annex 3 - 13

¹⁴ ISO 1496-4:1991, Series 1 freight containers – specification and testing – Part 4: Non pressurised containers for dry bulk.

¹⁵ A parallelepiped is a three-dimensional figure formed by six parallelograms. (The term rhomboid is also sometimes used with this meaning.

¹⁶ ISO 1496-1:1991 as amended, Freight containers – specification and testing – Part 1 General cargo containers for general purposes.

interior by a smaller right hand door only. Box type bulk containers with this design feature are not available for use as a general purpose container when not being employed as a bulk container.

These are specialised items of equipment and are generally located near companies that are actively involved with the transport of bulk materials. In Europe there are a number of specialist companies who provide complete logistics services for bulk dry materials.

Box and hopper type dry bulk containers comprise 5.1% of the dry freight special fleet or 0.2% of the entire maritime fleet of containers.

New type code designations are being introduced for all categories of dry bulk containers.

.2 Typical cargoes

These containers are suitable for all types of dry powder, granules and aggregate generally which are free flowing.

.3 Dimensions and volume

The majority of bulk containers in Europe are 30ft long and often 2.5 m wide and therefore should be considered as a swap body, however they have the appearance of an ISO container and are often confused with them.

In other parts of the world the majority of bulk containers are 20ft long although 40ft and 45ft containers have been built for transporting dry bulk materials.

.4 Minimum internal dimensions and volume

Similar to the 30ft GP Container

.5 Minimum door openings

For those units with doors, they are broadly similar to 8ft 6in and 9ft 6in high GP containers

.6 Rating and load distribution

Dry bulk containers are often built to meet the particular transport requirements of a customer or product. Maximum gross mass can be as high as 38 tonnes which require specialist road vehicles and handling equipment, but generally the maximum gross mass is higher than for a similar sized GP container.

30ft dry bulk containers in use in Europe may also be manufactured with reduced stacking capabilities, therefore are not suitable for stacking more than one fully laden container above it..

.7 Variations

Dry bulk containers for aggregate are generally built with larger loading and/or discharge hatches. They may also be built without a solid top, so blending the dry bulk container with the open top container.

3.1.5

Open top containers:

- .1 An open top container is similar to a general purpose container in all respects except that it has no permanent rigid roof. It may have a flexible and moveable or removable cover, e.g. of canvas, plastic or reinforced plastic material often referred to as a Tarpaulin, "tarp" or "Tilt". The cover is normally supported on movable or removable roof bows. In some cases the removable roof is fabricated from steel that can be fitted to or lift from the top of the open top container. Containers thus built have been known as 'solid top' containers.

The open top container is designed to operate with the tarpaulin or hard top fitted or not fitted, therefore to withstand the



Annex 3 - 14

loads exerted onto the side walls the top side rails are substantially larger than those of a GP container. For the traditional open top container, the top side rail also has to accommodate receptacles for the roof bows and loops for attaching the

tarpaulin. It is essential that the tarpaulin is the correct design and the eyelets on the tarpaulin match the eyes on the top side rail, front and back rails and around the corner fittings to ensure the best weathertightness and to permit the TIR wire to be threaded through all of them to maximise security.

The open top container was designed for two categories of cargo, those that are too heavy or difficult to load by conventional methods through the doors, or that are too tall for a standard GP container. The hard top, open top container caters for the former but due to the rigid roof, transporting tall cargoes may present problems with moving the roof to the destination.

The other feature of the open top container is the ability to pack tall items into the container through the doors, as the header (transverse top rail above the doors) are generally movable or removable (known as swinging headers). The swinging header either forms a trough into which the tarpaulin is attached or it folds over the front face of the header to prevent water runoff from entering the container. The header is held in place by hinges at each end adjacent to the corner fittings, and each hinge has a removable pin that so that the header can be swung out of the way. However it is advisable to remove both pins and lift the header down using a fork truck rather than leaving the header unsupported at one end.



Open top containers forms the largest type within dry freight specials, amounting to 193,095 containers or 1.1% of the total maritime fleet.

Open tops are generally 20ft or 40ft long and 8ft 6 in high. There are few 9ft 6 in

Annex 3 - 15

World Dry Freight Special Fleet		
	Containers	Share
Open-top	193,095	29.2%
Folding flatrack	151,067	22.8%
Cellular pallet-wide	85,356	12.9%
Dry bulk / silo	33,736	5.1%
Fixed flatrack	31,922	4.8%
Platform	16,312	2.5%
Other	150,448	22.7%
Total	661,936	

Source: World Container Census, 2010

Annex 3 - 16

high to cater for some cargoes and which will enable standard tarpaulins or hard tops to be used.

The simplest form of this type of container is given the ISO type code U).

.2 Typical cargoes

Open top containers carry a variety of tall and heavy, generally project type cargo. Regular cargoes include glass sheets mounted on special A frames often lifted in through the roof and covered using an over height tarpaulin, large diameter tyres for mine vehicles and scrap steel.



Annex 3 - 17

.3 Dimensions and volume

With the exception of the removable tarpaulin, roof, the dimensions are generally in line with

the GP container.

.4 Minimum internal dimensions and volume

Similar to the GP Container

.5 Minimum door openings

Similar to the 8ft 6in high GP containers

.6 Rating and load distribution

As GP container.

.7 Variations

There are few variations from the standard tarpaulin covered open top container. Many designs have been developed to ease the fitting and removal of the tarpaulin roof and roof bows. These include sliding tarpaulins which concertina towards the front of the container and captive roof bows that lift out on one side and hand from a bar on the other, thus reducing the risk of loss when an over height cargo is carried.

Hard top open top containers have been adapted to carry large steel coils or long bars.¹⁷ These specialist open top containers may have higher maximum gross mass values.

3.1.6

Open side containers:



Annex 3 - 18

- .1 The open side container was introduced into the maritime fleet as a GP container variation and as an alternative to the standard curtain sided trailer used in road transport. Original designs had a curtain on one or both sides, a rigid roof and rear doors. Without side walls the base structure had to be self-supporting, therefore required to be more substantial than the GP floor to achieve the same floor strength and load carrying capabilities. In this form the open side container took on some of the characteristics of the platform based container with complete superstructure.¹⁸ As a consequence of the self-supporting floor the tare generally increased.

To improve security some manufacturers offer solid doors in place of the curtains offering doors to one or both sides, with no rear doors, with doors at the rear of the container and with door at the front of the container, offering one, two, three and four side access.

The open side container is a specialist item of transport equipment, although the 45ft long and 2,5m wide pallet-wide curtain side variation is becoming more popular in Europe. However the full length side door 20ft long unit is also becoming popular also as a regional variation in other parts of the world.

.2 Typical cargoes

Open side containers are designed to carry packages that can be loaded using a fork truck, typically pallets and long



Annex 3 - 19

packages.

.3 Dimensions

As GP container.

¹⁷ Langh Ships

¹⁸ platform based container with a permanent fixed longitudinal load carrying structure between ends at the top.

.4 Minimum internal dimensions and volume

Similar to the GP Container although the internal height is reduced to approximately 2.4m.

.5 Minimum door openings

Reduced height to match the reduction of internal height.

.6 Rating and load distribution

Maximum gross mass is generally 34,000 kg for newer 45ft long units. 20ft units will be 30,480 kg or higher.

.7 Variations

Variations are available for specific trades, such as an open side container with a built in half height deck.

Other variations include internal full length or partial length central walls to provide support to the base structure and assist with pallet placement.



Annex 3 - 20



Annex 3 - 21

3.1.7

Platform based containers

- .1 Platform based containers are specific-purpose containers that have no side walls, but has a base structure. The simplest version is the platform container which has no superstructure whatsoever but is the same length, width, strength requirement and handling and securing features as required for interchange of its size within the ISO series of containers. There are approximately 16,300 platform containers in the maritime fleet.

The simplest form of platform container is given an ISO type code P0.

Since the platform container has no vertical superstructure, it is impossible to load one or more packages on it and then stack another container above it. To do this a platform based container with incomplete superstructure with vertical ends is required. The end structure can consist of posts, posts with transverse rails or complete end walls. The original designs for these were fitted with fixed end walls and were called flatracks.



Annex 3 - 22

There are approximately 32,000 fixed end flatracks in the maritime fleet.

Fixed end flatracks are given a ISO type code P1 for containers with full end walls and P2 for fixed flatracks with posts.

The next design innovation was to build a platform based container with folding ends which could act as a platform when the end walls / posts were folded down or as a flatrack with the end walls erected.

Folding flatracks are now the major project transport equipment with about 151,000 containers in service in the maritime fleet. They can be readily sourced in most locations, although there are areas where concentrations are greater to meet



Annex 3 - 23

local on-going demand.

Folding end flatracks are given an ISO type code P3 for units with full end walls and P4 for those with folding posts with or without removable top transverse member.

.2 Typical cargoes

The platform container and flatrack are used to transport out of gauge packages and items that need special handling. One of the most readily identifiable cargoes carried are road, farm and construction vehicles carried on flatracks or platforms because they are often over-height or width.

The modern flatrack is manufactured to transport heavy project equipment either as a discrete transport unit, or as part of a temporary 'tween deck where the heavy equipment can be loaded over two or more flatracks.

.3 Dimensions and volume

Platforms and fixed end flatracks are available in 20ft and 40ft lengths whereas folding flatracks are available in these two lengths plus a very limited number of 45ft long containers.

Folded flatracks can be stacked using the integral interconnectors for empty transport, forming an 8ft 6in high pile. 20ft folded flatracks are stacked in groups of 7 and 40ft in stacks of 4.



Annex 3 - 24

.4 Minimum internal dimensions and volume

Flatracks with end walls erected will have internal volume similar to the GP container, although the size of the corner posts will restrict the width at the ends. However most flatracks are built with end walls that create an 8ft 6in high container so that the distance between the deck and the top of the posts are approximately 1,953 mm (6ft 5in).

Owners, recognising that the more packages that they can fit "inside" the height of the flatrack walls, have started to build some flatracks with higher end walls thus forming a 9ft 6in high container.

A progression from that is the flatrack with extendable posts that takes the overall height to 13ft 6in high.

.5 Minimum door openings

No doors fitted

.6 Rating and load distribution

Flatrack maximum gross mass values have increased over the past years, rising from 30,480 kg to 45,000 kg and most 40ft flatracks are now built to this rating. This means that payloads of approximately 40 tonnes evenly distributed over the deck and supported by the side rails can be lifted and transported by suitable modes. Many flatrack owners will provide information on concentrated loads that can be carried centrally.

.7 Variations

There are a number of variations available from specialist flatrack suppliers, pipe carriers, coil carriers and car manufacturers to name but three. However these are generally held for specific trades and are few in number.



Annex 3 - 25

3.1.8 Thermal containers:

.1 A thermal container is a container that has

insulating walls, doors, floor and roof. Over the years the thermal container has evolved from a simple insulated container with no device for cooling and/or heating through refrigerated an insulated container cooled using expendable refrigerants such as ice, 'dry ice' (solid carbon dioxide), or liquefied gasses but again with no external power or fuel supply.

A variation of this design is the porthole container, which are refrigerated by cold air from an external source introduced through a porthole. This design is being phased out.

The most common variant of the thermal container is the integrated refrigerated container, often referred to as the "Reefer". The internal temperature is controlled by a refrigerating appliance such as a mechanical compressor unit or an absorption unit. The Reefer consists of a container body with insulated walls, sides and roof plus insulated doors at the rear. The front of the container body is left open for mounting the refrigeration machinery.

Refrigeration machinery is generally powered by 3-phase electricity supplied by a trailing lead that can be connected to sockets on board ship or in the terminal. Where there is insufficient power capacity freestanding "power packs" can be used. Power packs can also be used to supply power to a number of Reefers being carried by rail. When the Reefer is to be carried by road, unless the journey is relatively short, most cargo owners will require the reefer to be running and for this



Annex 3 - 26

nose mounted or trailer mounted generator set are available.

Where reefers are used to transport chilled or frozen cargo by road, some owners have integral refrigerated containers with the machinery including a diesel generator.

The refrigeration machinery works by passing air through the container from top to bottom. In general, the "warm" air is drawn off from the inside of the container, cooled in the refrigeration unit and then blown back in the container as cold air along the T floor grating.

To ensure adequate circulation of the cold air, the floor is provided with an "T" section gratings. Pallets form an additional space between container floor and cargo, so also forming a satisfactory air flow channel.

The last form of thermal containers are those that to operate within areas with low or very low ambient temperatures, often servicing areas of extreme cold such as Alaska. The design of which can be based on a thermal as described above except with a heating device, or by the use of a general purpose container fitted with internal insulation and heating filaments.

The mix of reefer units has changed over the last few years, new purchases of 20ft and 40ft long 8ft 6in high reefer containers has not matched the number of sales of old units, therefore the fleet size is shrinking. On the other hand the 40ft 9ft 6in high reefer has been growing with 150,000 added to the fleet in the last three years.

World Integral Reefer fleet		
	Containers	Share
20ft (8ft 6in)	140,660	15.3%
20ft (9ft 6in)	6,132	0.7%
40ft (8ft 6in)	16,854	1.8%
40ft (9ft 6in)	753,072	82.0%
Others	1,618	0.2%
Total	918,336	
Source: World Container Census, 2010		

Annex 3 - 27

Integral reefer containers have been given an ISO type code of R0.

.2 Typical cargoes

Reefer containers were developed to transport perishable cargoes. A "perishable" may be described as something that is easily injured or destroyed. Without careful treatment, the time taken to deteriorate to a condition which will either reduce the value or render it unsaleable (shelf life) may become unacceptably short.

Careful consideration of the factors affecting the "shelf life" of perishables should be made and applied during their transportation.

Perishables include frozen produce, meats, seafood, dairy products, fruit and vegetables, horticultural products such as flowering bulbs and fresh flowers plus chemical compounds and photographic materials.

.3 Dimensions and volume

Externally the same as 20ft, 40ft and 45ft GP containers.

.4 Minimum internal dimensions

ISO Refrigerated container internal dimensions												
Freight container description	Freight container designation	Length, L			Width, W			Height, H			Volume, V	
		mm	ft	in	mm	ft	in	mm	ft	in	m ³	ft ³
		45ft long x 9ft 6in high	1EEE	13,115	43	¼	2,294	7	6½	2,554.0	8	4½
40ft long x 9ft 6in high	1AAA	11,590	38		2,294	7	6½	2,554.0	8	4½	67.9	2,398
40ft long x 8ft 6in high	1AA							2,350.0	7	9½	62.5	2,697
20ft long x 9ft 6in high	1AAA	5,468	17	11	2,294	7	6½	2,554.0	8	4½	32.0	1,003
20ft long x 8ft 6in high	1AA							2,350.0	7	9½	29.5	1,081

Annex 3 - 28

.5 Minimum door openings

Door width 2,290 mm 7ft 6in,

Height for 9ft 6in high 2,570 mm 8ft 5in.

Height for 8ft 6in high 2,265 mm 7ft 5in.

.6 Rating and load distribution

The latest production of 20ft reefers has a maximum gross mass of 30,480kg and 40ft and 45ft long a maximum gross mass of 34,000kg

.7 Variations

Reefer can be fitted with a number of refrigeration units from different suppliers and those can also provide controlled atmosphere provisions.

Structurally, special designs have been produced for rail based equipment, 48, 53 and 58ft long and over wide units (2.6m).

3.2 Swap Bodies

3.3 Road Vehicles

3.4 Tank containers:

3.4.1 A tank container comprises two basic elements, the tank (barrel) or tanks and the framework and complies with the requirements of ISO 1496-3.¹⁹

3.4.2 In the freight container industry, the term “tank” or “tank container” usually refers to a 20ft tank container consisting of a stainless steel pressure vessel supported and protected within a steel frame.

3.4.3 However the tank container industry has developed a number of containment designs that carry all sorts of bulk liquids, powders, granules and liquefied gases, however it is important to differentiate bulk liquid and pressurised dry bulk tank containers from non-pressured dry bulk containers that may look very similar to a tank container.

3.4.4 The majority of the maritime tank container fleet is 20ft long and 8ft 6in high. The split between the major tank designs is not known although the most current production is generally Collar tanks. All the tank designs fulfil the requirements of the ISO standards.

The ISO tank type codes are being changed at the time of writing.

¹⁹ ISO 1406-3, Series 1 freight containers – Specification and testing – Part 3: Tank containers for liquids, gases and pressurised dry bulk.

World Tank fleet (liquid bulk)		
	Containers	Share
20ft	195,527	98.1%
40ft	1,218	0.6%
45ft	0	0.0%
Others	2,580	1.3%
Total	199,325	
Source: World Container Census, 2010		

3.4.5 General information

More information on tanks can be found below.

.1 Typical cargoes

Tank containers can carry practically all liquids from orange juice to whisky, and non hazardous to dangerous good.

.2 Dimensions and volume

Practically all maritime tank containers are 20ft long and 8ft 6in high.

.3 Minimum internal dimensions and volume

Volume vary from 9,000 litres to 27,000

.4 Minimum door openings

No doors fitted

.5 Rating and load distribution

Maximum gross mass for tank containers varies but is generally 34,000 kg.

.6 Variations

Tank containers can be supplied un-insulated or insulated, with steam heating, with electrical heating, with refrigerant plants attached, with cooling tubes.

Additionally the tank can be partitioned into a two or more discrete compartments or divided with baffle / surge plates

3.4.6 ISO Tank Containers

.1 Length 10ft (2.991m), 20ft (6.058m), 30ft (9.125m) and 40ft (12.192m). Under ISO 668 it would be possible to include a 45ft (17.192m) long unit to the list. However in the international tank industry approximately 95 % of all tanks built are 20ft long.

.2 Width 8ft (2.438m) wide

.3 Height Generally 8ft (2.438m) and 8ft 6in (2.591m). There are also "half high" tanks that are typically 4ft (1.219m) and 4ft 3in (1.296m) tall

.4 Volume 9,000 to 27,000 litres.

.5 Stacking The combined mass of the superimposed load shall not exceed the allowable stack weight shown on the Safety Approval Plate, generally 192,000 kg. Note: see section 12.2 for more information about stacking of loaded containers.

.6 Transport Can be carried on all modes of transport and deep and short sea routes within cells or on deck

3.4.7 Tank Swap Bodies

.1 Length Under European (CEN) standards the majority of tank swap bodies (often referred to as swap tanks) have a length of 7.15m, 7.45m, 7.85m or 13.6m. The

CEN standard EN 1432 for swap tanks also includes four other lengths: 6.05m (20ft), 7.15m, 9.125m (30ft) and 12.192m (40ft). However these standards do not appear to be used too often as many manufacturers produce different lengths of swap tanks to suit particular cargoes depending on road regulations (length and mass).

The most common length is 7.15m which has approximately 80% of the market.

- .2 Width 2.5m and 2.55m wide.
- .3 Height 2.670m (EN 1432) and 2.591m.
- .4 Volume 30,000 to 36,000 litres.
- .5 Stacking Some designs can be stacked but this is an optional feature in EN 1432. Where they can be stacked they are tested for a superimposed mass of two identical, laden tanks. Note: see section 12.2 for more information about stacking of loaded containers.
- .6 Transport Originally designed for road, rail and RO-RO / short sea and often not stacked. Swap tanks with top lift capability can be stacked on deck on deep sea vessels.

Tank swap bodies have reduced stacking capability when compared with ISO designs. This precludes stacking of these units in the lower tiers of an on-deck stow. The extra width of the design, prevents stacking within most deep sea cells or adjacent to other containers on deck

3.4.8 Tank Designs

ISO Tank Containers

There are three main structural types of tank container used in the international transport of bulk liquids and liquefied gases - beam, frame and collar. All designs have been manufactured since the 1970s.

All designs can be top lifted, must be stackable and the pressure vessel / barrel as well as all valves and other service equipment must remain within the ISO envelope, i.e. no part can protrude past the outer faces of the corner fittings.

.1 Frame Tanks

This design consists of two end frames separated by two main beams at low level forming a support frame. Since there is more material in the support frame than with other designs the tare is relatively high. Often the lower beams are "castellated" a method of lightening the main beams by cutting holes to reduce the tare and therefore to increase the payload. Top rails are often light weight, play little part in the overall structural strength and often there to support the walkway. Top rails in these cases are not usually attached to the pressure vessel. In some designs these rails can be attached using mechanical fasteners (nuts and bolts) but are more often welded in place.

- .2 The pressure vessel is supported from the main beams generally on saddle supports which are in the form of bolted clamps or welded interface supports.



Annex 3 - 29



Annex 3 - 30

- .3 The two pictures above show a 20,000 litre (Annex 3 - 29) and a 25,000 litre design (Annex 3 - 30). Both are insulated. Both pictures show the cut away castellated light weight main beam. It is also possible to see that the beam is elevated above the level of the corner fitting in Annex 3 - 30 whereas Annex 3 - 29 shows the beam is lower with the bottom face of the beam about 16 mm above the lower face of the bottom corner fitting, This also shows a top rail significantly lower than its top corner fittings.

.4 Beam Tanks

A beam tank is supported by a series of bearers attached to the end frames which interface with the pressure vessel at various locations on the periphery of the barrel. The interface consists of plates that are welded to the pressure vessel and the bearers to ensure load sharing and a "barrier" between carbon steel and stainless steel components.

The example shown in annex 3 - 31 is a typical beam tank with no top or bottom side rails. The tank is attached using four beams that connect at the four corner fittings of each end frame. The walkway is supported using brackets attached to the pressure vessel.



Annex 3 - 31

Annex 3 32 shows a different design where the attachment of the pressure vessel is made using fabricated brackets attached to the corner posts and the end frame corner braces. Top side rails are fitted to the top corner fittings.

The tank container is also un-insulated.

Both examples show low volume pressure vessels 17,500 lt.



Annex 3 - 32

Annex 3 - 33 shows four 10ft ISO International beam tanks, being carried as two 20ft units. In this example two 10ft units are connected using approved horizontal interbox connectors and the design tested in that configuration. They can then be loaded, handled and stowed in the same way as any 20ft ISO tank container.



Annex 3 - 33

.5 Collar Tanks

The collar tank is probably the simplest of all the tank designs with a minimum of differing materials in contact with the pressure vessel. Attachment of the pressure vessel to the end frames is by means of a stainless steel collar which is welded to the pressure vessel end dome at the edge (out-set) or to the crown of the domed ends of the pressure vessel (in-set). The collar connects with the side posts, top and bottom rails and the diagonal braces via interface flanges.

The collar is continuous at the front / non discharge end. At the rear of the tank container some collar tank designs have a break in the collar where the discharge valve is located.

Annex 3 - 33 shows an insulated 25,000 litre collar tank. Once insulated it is virtually impossible to distinguish between the inset and outset collar design.



Annex 3 - 34

3.4.9 Tank Swap Bodies (Swap Tanks)

The options for the design of the swap tanks are far less sophisticated than for ISO tanks. However the most important difference relates to their handling and stacking capabilities. All swap tanks have bottom fittings at the ISO 20ft or 40ft locations. Generally the bottom fittings are wider than their ISO counterparts, this is so that the bottom aperture is in the correct ISO position / width while the outer face of the bottom fitting extends to the full width of the unit (2.5 / 2.55m).

3.4.10 Stackable

- .1 The majority of recently built swap tanks are now stackable and 85 % of all swap tanks have top and side lifting capability.
- .2 When considering stacking swap tanks it is important to differentiate between swap tanks and ISO containers which can be done by looking at the configuration of the top fitting and the side post. One of the characteristics that will be seen on the majority of all of these units is the double side lifting aperture, one in the post and the other in the fitting as shown in Annex 3 - 34. The second aperture in the post is required so that the unit can be lifted using a side lifter.



Annex 3 - 35

- .3 The second identifying characteristic is the stepped back top fitting. As the top fittings are generally the same as those found on ISO tank containers, the positioning must be identical to that of the 20ft / 40ft ISO container; the fitting is set back from the post face to accomplish this.
- .4 A typical example of a swap tank is shown in Annex 3 - 35. The pressure vessel is attached to the "end" frames and there is a protective bottom rail / end frame to ensure



Annex 3 - 36

that the risk of direct contact with the pressure vessel is minimised.

.5 The unit is insulated.

.6 The example shown in Annex 3 - 36 is a 12.192m long powder tank with top lift capabilities. Note the presence of the two apertures in the side posts and corner fittings indicating that the container is wider than ISO. This design is similar to



Annex 3 - 37

that of the ISO collar tank.

.7 The swap tank should never be lifted from the side when loaded.

3.4.11 Non Stackable

.1 There are swap tanks which are not stackable or capable for lifting using traditional spreaders. The design of these earlier models was similar to the frame tank with the pressure vessel being supported from the bottom side beams. Some non stackable swap tanks are still built today to meet the particular needs of the industry, particularly intra-European.

.2 Annex 3 - 37 shows an example of a modern non stackable demountable swap tank. The notable features are the two grapple lift points (highlighted in yellow and arrowed). The second feature is the legs which are shown in the erected (down) position. Legs of this design enable the swap tank to be demounted from the transport truck / trailer and left for loading, unloading or storage.



Annex 3 - 38



3.4.12

Named cargo containers:

Named cargo types of containers are containers built in general accordance with ISO standards either solely or principally for the carriage of named cargo such as cars or livestock.

One particular container type is the Power Pack, which can be used to supply electrical 3 phase electricity to reefer container when carried by rail, to supplement or provide power on board power during sea transport or to supplement or



Annex 3 - 39

provide power in terminals.

A power pack would typically consist of a diesel generator set (250kW-700kW) with up to 64 sockets. They can include built in fuel tanks for the generator or use a 20ft tank container carried in an adjacent slot.

Externally it will be the same as a 20ft GP container.



3.5 European Swap Body

3.5.1 General

- .1 An item of transport equipment having a mechanical strength designed only for rail and road vehicle transport by land or by ferry, and therefore not needing to fulfil the same requirements as series 1 ISO containers; having a width and/or a length exceeding those of series 1 ISO containers of equivalent basic size, for better utilisation of the dimensions specified for road traffic;
- .2 Swap bodies are generally 2.5 m or 2.55 m wide although thermal swap bodies can be up to 2.6 m wide.
- .3 Swap bodies generally fall into three length categories:
 - .4 Class A: 13.6 or 13.712 m (45 ft) long
 - .5 Class B: 30 ft long
 - .6 Class C: 7.15, 7.45 or 7.8 m long. The most commonly used length in this class is 7.45 m
- .7 Swap bodies are fixed and secured to the vehicles with the same devices as those of series 1 ISO containers: for this reason, such devices are fixed as specified in ISO 668 and ISO 1161, but owing to the size difference. are not always located at the swap body corners,
- .8 Stackable swap bodies will have top fittings, where the external faces are 2.438 m (8 ft) when measured across the unit and 2.259 m between aperture centres. The placing of the top corner fittings is such that the container can be handled using standard ISO container handling equipment. In addition the container can be handled using grapple arms, although this lifting method appears to be becoming less common.
- .9 They may be stacked although the stacking capability is likely to be well below that of the ISO container. Before stacking the container handler must check the stacking strength shown on the Safety Approval Plate, but the stackable swap

body can be handled in the same way that series 1 ISO containers can. Swap bodies will have bottom castings that are either the same width as the swap body itself, or 2.428 m apart when measured across the unit to the external faces of the castings. They will also have a distance of 2.259 m between aperture centres when measured across the unit.

- .10 Class C swap bodies, can be transferred from the road vehicle to their supporting legs and re- turned to them by on-board means.

3.5.2 Box type swap body:

The standard box type swap body will have a rigid roof, side walls and end walls, and a floor and with at least one of its end walls or side walls equipped with doors. There are a number of variations to the basic design that can include units fitted with roller shutter rear door, hinged or roller shutter side doors to one or both sides and Garment carriers which is a box type swap body with single or multiple vertical or horizontal tracks for holding transverse garment rails.



Annex 3 - 41

3.5.3 Open side swap body:

The open side swap body falls into a number of different variations all designed to provide a similar access to standard trailer bodies. All designs will be an enclosed structure with rigid roof and end walls and a floor. The end walls may be fitted with doors.

- .1 Curtain side unit: swap body with movable or removable canvas or plastic material side walls normally supported on movable or removable roof bows.
- .2 Drop side swap bodies: swap bodies with folding or removable partial height side walls and movable or removable canvas or plastic material side walls above normally supported on movable or removable roof bows.
- .3 Tautliner: swap body with flexible, movable side walls (e.g. made of canvas or plastic material normally supported on movable webbing).
- .4 Gated tautliner – swap body fitted with a swinging gate at either end to provide top lift or stacking capability at the 20 or 40 ft positions. A flexible, movable side wall may be fitted between the gates or over the full length of the swap body.
- .5 Full length side door: swap body with full length concertina doors to one or both sides



Annex 3 - 42

3.5.4 Thermal swap body:

A thermal swap body is a swap body that has insulating walls, doors, floor and roof. Thermal swap bodies may be: insulated - with no device for cooling and/or heating, refrigerated - using expendable refrigerants such as ice, 'dry ice' (solid carbon dioxide), or liquefied gasses, and with no external power or fuel supply. Like the ISO container there are variants to this basic design such as the mechanically refrigerated swap reefer.

3.5.5 Swap tank:

A swap tank is a swap body that includes two basic elements, the tank or tanks, and the framework. Unlike the ISO tank container the tank barrel is not always fully enclosed by the frame work which may present a risk of damage another container or object falls onto the exposed tank barrel.

3.5.6 Swap Bulker:

A swap bulker is a swap body that consists of a cargo carrying structure for the carriage of dry solids in bulk without packaging. It may be fitted with one or more round or rectangular loading hatches in the roof and "cat flap" or "letter box"

discharge hatches in the rear and/or front ends. Identical in most ways to the ISO bulk container except that it may have reduced stacking capability. Often 30ft long.

3.6 Regional or domestic containers

Domestic containers are those containers that:

- .1 have a mechanical strength designed only for rail and road vehicle transport by land or by ferry, and therefore not needing to fulfil the same requirements as series 1 ISO containers and;
- .2 can be of any width and/or length to suit national legislation for better utilisation of the dimensions specified for road traffic. In general they will be 2.5 or 2.6 m or 8ft 6 in wide.
- .3 may have castings at least at each corner and suitable for top lifting;
- .4 may have corner castings that are the same width as the width of the container when measured across the unit to the external faces of the castings.
- .5 may be stacked.
- .6 Domestic containers may be general cargo containers or specific cargo containers as defined in 5.1 or 5.2 above.

4.0 Avoiding condensation

- 4.1 Cargoes in transit may be affected by the conditions to which they are subjected. These conditions may include changes in temperature and humidity and particularly cyclic changes that may be encountered. An understanding of condensation phenomena is desirable because condensation may lead to such damage as rust, discoloration, dislodging of labels, collapse of fibreboard packages or mould formation.
- 4.2 Solar radiation can produce air temperatures under the inner surfaces of a CTU which are significantly higher than external air temperatures. The combination of these effects can result in a range of day and night cyclic temperature variations in the air adjacent to the inner surfaces of a CTU which is greater than the corresponding range of temperatures just outside.
- 4.3 Cargoes closest to the walls or roof will be more affected by external temperature variations than those in the centre of a CTU. If the possible extent of temperature variations or their full significance is not known, advice should be obtained from specialists.
- 4.4 Under the circumstances described, condensation may occur either on the surface of the cargo (cargo sweat) or on the inside surfaces of a CTU (container sweat) either during transport or when the unit is opened for discharge.
- 4.5 The main factors leading to condensation inside a CTU are:
 - 4.5.1 sources of moisture inside the unit which, depending on ambient temperature conditions, will affect the moisture content of the atmosphere in the unit;
 - 4.5.2 a difference between the temperature of the atmosphere within the unit and the surface temperature of either the cargo or the inner surfaces of the unit itself; and
 - 4.5.3 changes in the temperature of the outer surface of the unit which affect the two factors above.

- 4.6 Warming the air in a CTU causes it to absorb moisture from packagings or any other source. Cooling the air below its dewpoint²⁰ causes condensation.
- 4.7 if, after high humidity has been established inside a CTU, the outside of the unit is cooled, then the temperature of the unit surface may fall below the dewpoint of the air inside it. Under these circumstances moisture will form on the inner surfaces of the unit. After forming under the roof, the moisture may drop onto the cargo. Cyclical repetition of cargo or container sweat phenomena can result in a greater degree of damage.
- 4.8 Condensation can also occur immediately after a CTU is opened if the air inside the unit is humid and the outside air is relatively cool. Such conditions can produce a fog and even precipitation but, because this phenomenon usually occurs only once, it seldom results in serious damage.
- 4.9 The risk of damage and dangerous situations²¹ can be minimized if the moisture content of the packaging and securing materials is kept low.
- 4.10
- 5.0 Securing Techniques
Detailed securing techniques similar to Container Handbook.
- 6.0 Lashing Requirements
Detailed description of lashing forces and number of straps / lashings etc.
- 7.0 Friction and safety factor
(Text drawn from Model Course and CSS Code if required for certain types of CTU)
- 8.0 Other Regulations and Conventions [Examples shown below]
- 8.1 Customs Convention for Containers
- 8.2 International Convention for Safe Containers
- 8.3 IMDG Code
- 8.4 Rotterdam Rules
- 8.5 TIR
- 8.6 others
- 9.0 List of relevant international organisations
- 10.0 Topics to be included in a training programme for the packing and securing of cargoes in cargo transport units (CTUs)

²⁰ The dewpoint is the temperature at which air saturated with moisture at the prevailing atmospheric pressure will start to shed moisture by condensation.

²¹ For example, when dangerous cargoes of class 4.3 (dangerous when wet) are packed in a container