

## **Proposal of amendments to ECE/TRANS/WP.29/2010/127 (Draft Regulation on pedestrian safety)**

### **Test area and Measuring point**

#### **I. Proposal**

*Paragraph 2.1.*, amend to read:

“2.1. “Adult headform test area” is an area on the outer surfaces of the front structure. The area is bounded ~~in the front by a wrap around distance:(WAD) of 1,700 mm and, at the rear, by the rear reference line for adult headform and, at each side, by the side reference line.:~~

- (a) **in the front, by a wrap around distance (WAD) of 1,700 or a line 82.5 mm rearward of the bonnet leading edge reference line, whichever is most rearward at a given lateral position,**
- (b) **at the rear, by a WAD 2,100 or a line 82.5 mm forward of the bonnet rear reference line, whichever is most forward at a given lateral position, and**
- (c) **at each side, by a line 82.5 mm inside the side reference line.”**

**The distance of 82.5 mm is to be set with a flexible tape held tautly along the outer surface of the vehicle.”**

*Paragraph 2.13.*, amend to read:

“2.13. “Child headform test area” is an area on the outer surfaces of the front structure. The area is bounded, ~~in the front, by the front reference line for child headform, and, at the rear, by the WAD1700 line, and by the side reference lines.:~~

- (a) **in the front, by a WAD 1,000 or a line 82.5 mm rearward of the bonnet leading edge reference line, whichever is most rearward at a given lateral position,**
- (b) **at the rear, by a WAD 1,700 or a line 82.5 mm forward of the bonnet rear reference line, whichever is most forward at a given lateral position, and**
- (c) **at each side, by a line 82.5 mm inside the side reference line.”**

**The distance of 82.5 mm is to be set with a flexible tape held tautly along the outer surface of the vehicle.”**

*Paragraph 2.22.*, amend to read:

“2.22. ~~Impact~~ **First contact point**” means the point on the vehicle where initial contact by the test impactor occurs. The proximity of this point to the target point is dependent upon both the angle of travel by the test impactor and the contour of the vehicle surface (see point **C B** in Figure 7B and Figure 7C).”

**[The first contact point is sometimes also referred to as “impact point” in respective regular texts for pedestrian protection.]”**

Delete old figure 7 and add new Figures 7A, 7B and 7C, as follows:

Figure 7A

### Geometry of an headform to bonnet impact

#### Measuring and target point

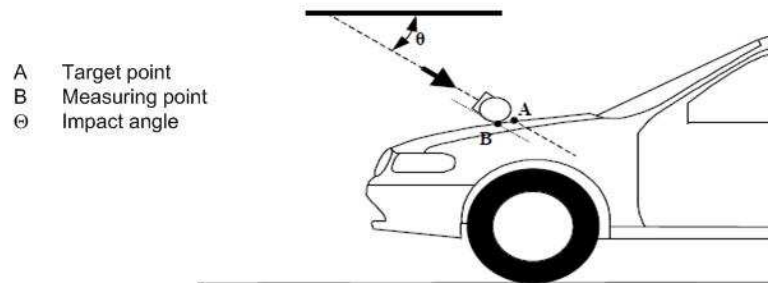
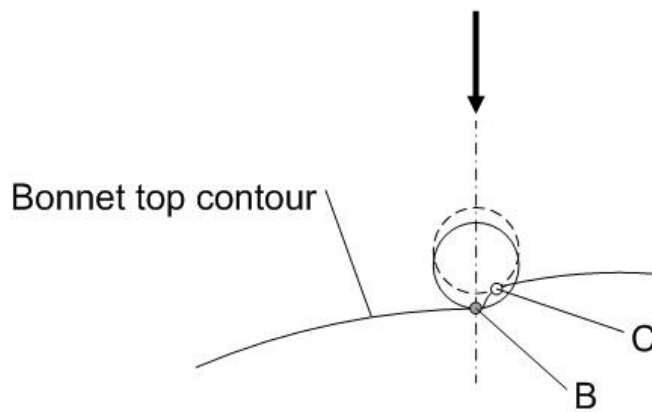

Figure 7B

#### Measuring and first contact point (schematic front view)



- B Measuring Point
- C First Contact Point

**Remark:** Due to the spatial geometry of the bonnet top, the first contact point C does, in most cases, not lie in the same vertical longitudinal or transverse plane which contains measuring point B.

Figure 7C

Geometry of a Lower/Upper legform to bumper impact

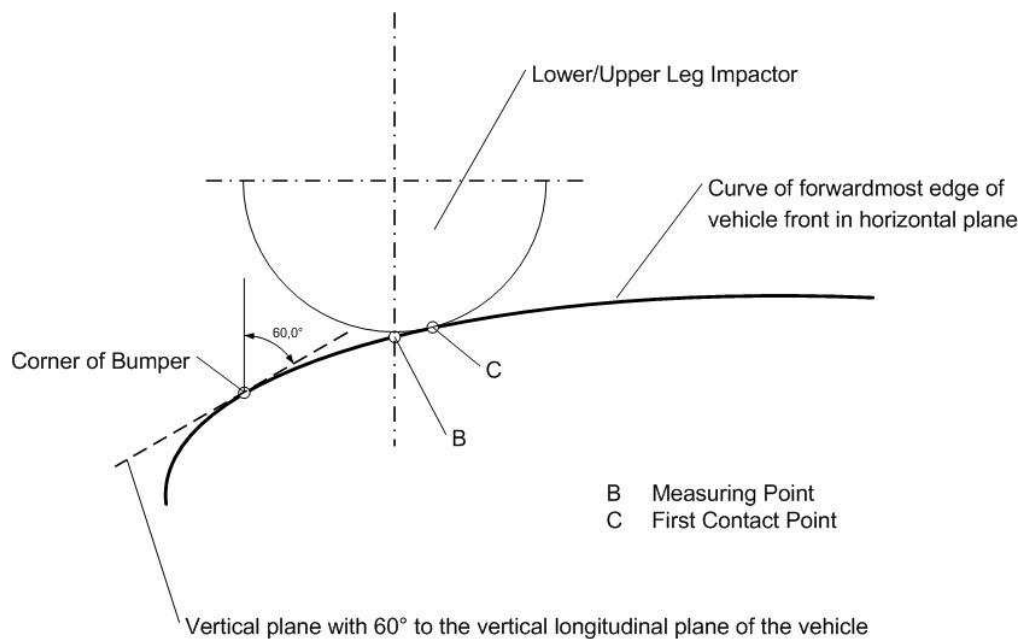

Paragraph 2.29., amend to read:

“2.29. “Target point” means the intersection of the projection of the headform longitudinal axis with the front surface of the vehicle (see point A in Figure 7A).

**[The target point is sometimes also referred to as “aiming point” in respective regular texts for pedestrian protection.]**

Paragraph 2.30., delete

~~“2.30. “Third of the bonnet leading edge” means the geometric trace between the corner-reference points, measured with a flexible tape following the outer contour of the leading edge, divided in three equal parts.”~~

Paragraph 2.31., amend to read:

“2.31. “Third of the bonnet top” means the geometric trace of the area between **the side boundaries of the bonnet top test area**, measured with a flexible tape following the outer contour of the bonnet top on any transverse section, divided in three equal parts.”

Paragraph 2.32., amend to read:

“2.32. “Third of the bumper” means the geometric trace between **the side boundaries of the bumper test area**, measured with a flexible tape following the outer contour of the bumper, divided in three equal parts.”

Add a new Paragraph 2.41, to read:

“2.41. **The measuring point for the headform test is a point in the vertical longitudinal plane of the vehicle, containing the centre of the impactor. In this plane, it is the point at which the impactor nominally first contacts the bonnet top (see point B in Figure 7A and 7B). The first contact point may differ from the measuring point as a result of the geometry of the bonnet top.**”

[The measuring point is sometimes referred to as “test point” or “selected impact point” in respective regulatory texts for pedestrian protection.]

Add a new *Paragraph 2.42*, to read:

**“2.42. The measuring point for the lower legform to bumper test and upper legform to bumper test lies in a vertical longitudinal plane containing the central axis of the impactor. The first contact point may differ from the measuring point as a result of the geometry of the vehicle front.”**

Add a new *Paragraph 2.43*, to read:

**“2.43. “Bonnet top test area” is composed of the child headform test area and the adult headform test area as defined in Paragraph 2.1 and 2.13 respectively.”**

*Paragraph 5.2.1.*, amend to read:

**“5.2.1. Child and adult headform tests:**

When tested in accordance with Annex 5, paragraphs 3., 4., and 5., the HIC recorded shall not exceed 1,000 over two thirds of the **bonnet top** ~~combined child and adult headform~~ test areas. The HIC for the remaining areas shall not exceed 1,700 for both headforms.

In case there is only a child headform test area, the HIC recorded shall not exceed 1,000 over two thirds of the test area. For the remaining area the HIC shall not exceed 1,700.”

*Annex 5, Paragraph 1.4.*, amend to read:

**“1.4. The selected ~~measuring target~~ points shall be in the bumper test area.”**

*Annex 5, Paragraph 1.5.*, amend to read:

**“1.5. A minimum of three lower legform to bumper tests shall be carried out, one each to the middle and the outer thirds of the bumper at positions judged to be the most likely to cause injury. Tests shall be to different types of structure, where they vary throughout the area to be assessed. The selected ~~measuring test~~ points shall be a minimum of 132 mm apart, and a minimum of 66 mm inside the defined corners of the bumper. These minimum distances are to be set with a flexible tape held tautly along the outer surface of the vehicle. The positions tested by the laboratories shall be indicated in the test report.”**

*Annex 5, Paragraph 1.10.*, amend to read:

**1.10. ~~At the time of first contact the centre line of the impactor shall be within a ±10 mm tolerance to the selected impact location. For lower leg testing, an impact tolerance of ± 10 mm shall apply.”~~**

*Annex 5, Paragraph 2.4.*, amend to read:

**“2.4. The selected ~~measuring target~~ points shall be in the bumper test area as defined in paragraph 2.11.”**

*Annex 5, Paragraph 2.5.*, amend to read:

**“2.5. A minimum of three ~~upper lower~~ legform to bumper tests shall be carried out, one each to the middle and the outer thirds of the bumper at positions judged to be the most likely to cause injury. Tests shall be to different types of structure, where they vary throughout the area to be assessed. The selected ~~measuring test~~ points shall be a minimum of 132 mm apart, and a minimum of 66 mm inside the defined corners of the bumper. These minimum distances are to be set with a flexible tape held taut along the outer surface of the vehicle. The positions tested by the laboratories shall be indicated in the test report.”**

*Annex 5, Paragraph 2.6.*, amend to read:

“2.6. The direction of impact shall be parallel to the longitudinal axis of the vehicle, with the axis of the upper legform vertical at the time of first contact. The tolerance to this direction is  $\pm 2^\circ$ .

**At the time of first contact the impactor centre line shall be vertically midway between the upper bumper reference line and the lower bumper reference line with a  $\pm 10$  mm tolerance and the impactor vertical centre line shall be positioned laterally with a tolerance of  $\pm 10$  mm.”**

*Annex 5, Paragraph 3.3.1.*, amend to read:

“3.3.1. The acceleration time histories shall be recorded, and HIC shall be calculated. The first **contact** point ~~of contact~~ on the front structure of the vehicle shall be recorded. Recording of test results shall be in accordance with ISO 6487:2002.”

*Annex 5, Paragraph 3.4.1.*, amend to read:

“3.4.1. The manufacturer shall identify the zones of the bonnet top **test area** where the HIC must not exceed 1,000 (HIC1000 zone) or 1,700 (HIC1700 zone) (see Figure 3).”

*Annex 5, Paragraph 3.4.2.* amend to read:

“3.4.2. Marking of the “bonnet top ~~test impact~~ area “ as well as “HIC1000 zone” and “HIC1700 zone” will be based on a drawing supplied by the manufacturer, when viewed from a horizontal plane above the vehicle that is parallel to the vehicle horizontal zero plane. A sufficient number of x and y co-ordinates shall be supplied by the manufacturer to mark up the areas on the actual vehicle while considering the vehicle outer contour in the z direction.”

*Annex 5, Paragraph 3.4.3.*, amend to read:

“3.4.3. The areas of “HIC1000 zone” and “HIC1700 zone” may consist of several parts, with the number of these parts not being limited. The determination of the impacted zone is done by the **measuring point, irrespective of the position of the** first contact point ~~of the headform~~ with the bonnet top.”

*Annex 5, Paragraph 3.4.4.*, amend to read:

“3.4.4. The calculation of the surface of the **bonnet top test impact** area as well as the surface areas of “HIC1000 zone” and “HIC1700 zone” shall be done on the basis of a projected bonnet when viewed from a horizontal plane parallel to the horizontal zero plane above the vehicle, on the basis of the drawing data supplied by the manufacturer.”

Annex 5, delete old Figure 3 and replace it by the new figure 3 as follows:

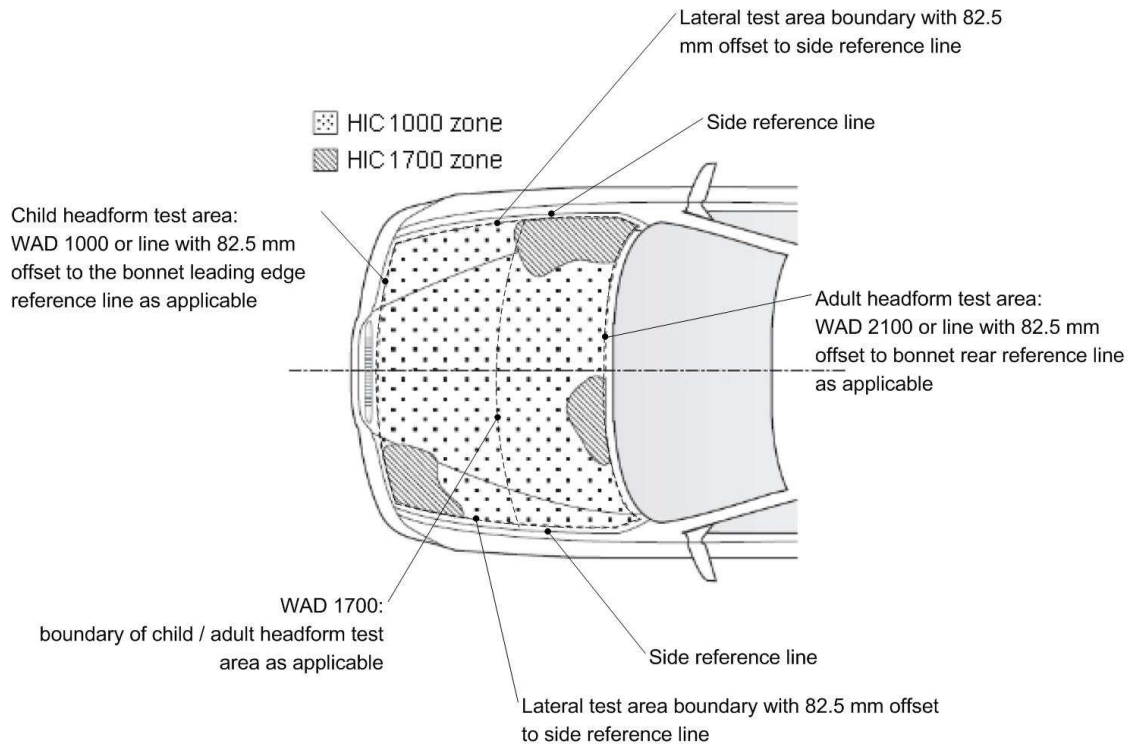

Annex 5, Paragraph 3.5., amend to read:

“3.5. ~~Impact test points~~ **Measuring point selection** – Particular specifications

Annex 5, Paragraph 4.2., amend to read:

“4.2. A minimum of nine tests shall be carried out with the child headform impactor, three tests each to the middle and the outer thirds of the child/~~small adult~~ bonnet top test areas, at positions judged to be the most likely to cause injury.

Tests shall be to different types of structure, where these vary throughout the area to be assessed and at positions judged to be the most likely to cause injury.”

Annex 5, Paragraph 4.3., amend to read:

“4.3 The selected **measuring** points for the child/~~small adult~~ headform impactor shall be ~~at the time of first contact:~~

- (a) A minimum of 165 mm apart, and
- ~~(b) A minimum of 82.5 mm inside the defined side reference lines, and;~~
- ~~(c) Forward of the WAD1700 line or a minimum of 82.5 mm forward of the bonnet rear reference line, whichever is most forward at the point of measurement, and~~
- ~~(d) Rearward of the WAD1000 line, or a minimum of 82.5 mm rearward of the bonnet leading edge reference line, whichever is most rearward at the point of measurement.~~
- (b) within the child headform test area as defined in 2.13.**

These minimum distances are to be set with a flexible tape held tautly along the outer surface of the vehicle.”

*Annex 5, Paragraph 4.4.*, amend to read:

“4.4. No ~~impact-measuring~~ point shall be located so that the impactor will impact the test area with a glancing blow resulting in a more severe second impact outside the test area.”

*Annex 5, Paragraph 4.5.*, amend to read:

“4.5. ~~The point of first contact point of the headform impactor shall be within a  $\pm 10$  mm tolerance to the selected impact point.~~ **For head impact testing, an impact tolerance of  $\pm 10$  mm shall apply.**”

*Annex 5, Paragraph 5.3.*, amend to read:

“ 5.3. ~~The Sselected measuring impact~~ points on the bonnet for the adult headform impactor shall be, ~~at the time of first contact:~~

- (a) A minimum of 165 mm apart, and
  - ~~(b) A minimum of 82.5 mm inside the defined side reference lines, and;~~
  - ~~(c) Forward of the WAD2100 line or a minimum of 82.5 mm forward of the bonnet rear reference line, whichever is most forward at the point of measurement, and~~
  - ~~(d) Rearward of the WAD1700 line, or a minimum of 82.5 mm rearward of the bonnet leading edge reference line, whichever is most rearward at the point of measurement.~~
- (b) within the adult headform test area as defined in 2.1.**

These minimum distances are to be set with a flexible tape held tautly along the outer surface of the vehicle.”

*Annex 5, Paragraph 5.4.*, amend to read:

“5.4. No ~~impact-measuring~~ point shall be located so that the impactor will impact the test area with a glancing blow resulting in a more severe second impact outside the test area.”

*Annex 5, Paragraph 5.5.*, amend to read:

“5.5. ~~The point of first contact point of the headform impactor shall be within a  $\pm 10$  mm tolerance to the selected impact point.~~ **For head impact testing, an impact tolerance of  $\pm 10$  mm shall apply.**”

## II. Justification

With document GRSP-48-27, OICA had explained that from Industry's point of view there is an issue with the current wording used in gtr no. 9 and the draft ECE Regulation. This especially concerns the use of the first contact point as the main reference point for testing. Especially the latest corrigendum, corrigendum no. 2 to gtr no. 9, made this more obvious for the future application of gtr no. 9 by the signatories to the 1998 Agreement of UNECE as well as the ECE Regulation by the signatories to the 1958 Agreement of UNECE.

Following the presentation of the document mentioned above, GRSP had agreed in its December 2010 session that OICA may propose necessary changes to make the test procedure clearer.

From the experiences collected during the application of existing pedestrian safety legislation in Japan and Europe it had been noted that the first contact point may not be appropriate as the main reference point for testing. It is true that a first contact always will be achieved. However, there are points on the bonnet surface that may be identified as being of interest (due to underlying structures, hard points etc.) but where a direct first contact of this point is impossible

due to the bonnet design. Assuming that the main impact energy is transferred in the centre-plane of the impactor that also contains the centre of gravity of the impactor it will nevertheless be possible to test such points, to achieve first contacts in the surrounding area and to allocate test results to such points. Industry feels that this procedure is clearer since it can be used for every point within the borderlines of the test area on the bonnet surface, independent of whether a point can be contacted by the headform during a test or not. Furthermore, the procedure allows a well defined positioning of the impactor while a first contact may be achieved with different points of the impactor's surface. Finally, the procedure will guarantee that vehicles of the same widths have an identical width of the test area.

This document contains the necessary changes to the gtr no. 9 wording and the draft ECE Regulation wording considering the headform test as a three-dimensional system of

- a measuring point (the point being closest to an underlying structure, to hard points etc.; this point sometimes is also referred to as test point or impact point),
- a target point (the point the propelling device targets to; sometimes also referred to as aiming point),
- a first contact point (the point where the initial contact of the impactor with the bonnet surface occurs; sometimes also referred to as impact point).

In this spatial geometry, the measuring point as well as the target point are always in the centre-plane of the impactor that is aligned to the vertical longitudinal plane of the vehicle. The test result achieved (i.e. an HIC value) shall always be allocated to the measuring point, independent of where the first contact occurred.

In addition to the three-dimensional definition of the point to be tested, OICA noted a discrepancy in the definition of the headform test area: According to the current test procedure described in gtr no 9 and the draft ECE Regulation can occur only within the child and/or adult headform test area excluding an offset of 1/2 headform diameter. The calculation of the HIC 1000 or the HIC 1700 zones respectively is nevertheless done for the whole area between the side reference lines. In practice, this could create a situation of possible misinterpretation when assigning the HIC zones to the bonnet surface since it may be possible to assign the less challenging criterion to areas that cannot be tested. The wording proposed with this document provides a clear procedure, i.e. the HIC value is to be calculated only for the area to be tested. Consequently this leads to a smaller HIC 1700 area in total which will contribute to increased safety of pedestrians.

This document also clarifies the same approach for the legform impactor test geometry of aligning the impactor's centre-plane with the measuring point as described above for the headform impactor.

Again, OICA wishes to point out that the changes to the procedures as described above are based on the experiences collected since gtr no. 9 was discussed in the Informal Group on Pedestrian Safety (INF GR PS). In the meantime, several experiences could be collected when testing vehicles to comply with legislation in Japan and Europe as well as with consumer requirements around the world. The procedures represent common practice in regulatory use. The proposed changes will contribute to the clearness of future worldwide pedestrian protection regulations in order to minimize the room for interpretations when the gtr no. 9 or the draft ECE regulation will enter into force in national legislation of the Contracting Parties.

OICA therefore would appreciate if the changes were accepted by GRSP and WP.29 respectively as soon as possible to have consistent test procedures around the world.

---