

**Proposal to amendments to ECE/TRANS/WP.29/2011/42  
(Revision of the Consolidated Resolution on the Construction of Vehicles (R.E.3))**

Note: The text reproduced below was adopted by GRSP at its 48th session on and proposes amendments to the proposal to develop amendments to Revision of the Consolidated Resolution on the Construction of Vehicles (R.E.3). This document is an update of ECE/TRANS/WP.29/2011/42, as reproduced in Annex V of ECE/TRANS/WP.29/GRSP/48. The modifications to ECE/TRANS/WP.29/2011/42 are marked in bold and strikethrough characters.

## I. Proposal

"...

Paragraphs 2.2.4.4. and 2.2.4.5., amend to read:

"2.2.4.4. *Class A:* Vehicles designed to carry standing passengers; a vehicle of this class has seats and may have provision for standing passengers **and having a capacity not exceeding 22 passengers in addition to the driver.**

2.2.4.5. *Class B:* Vehicles not designed to carry standing **and having a capacity not exceeding 22 passengers in addition to the driver."**

...

Annex 1, Appendix 1, Figure 2, amend to read:

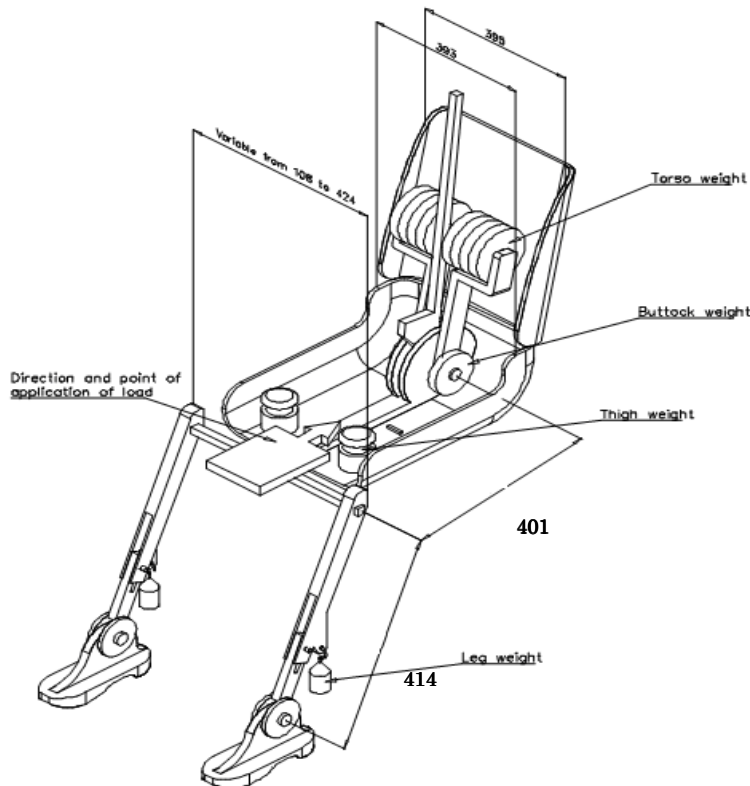

...

"..."

---

## **II. Justification**

The expert from Japan at the December 2010 session of GRSP introduced GRSP-38-29 amending ECE/TRANS/WP.29/2010/145 (now ECE/TRANS/WP.29/2011/42). GRSP adopted it with further amendments concerning the dimensions of the 3-D H- machine elements (see ECE/TRANS/WP.29/GRSP/48 para. 48)

---