



# Economic and Social Council

Distr.: General  
29 July 2011

Original: English

---

## Economic Commission for Europe

### Inland Transport Committee

### World Forum for Harmonization of Vehicle Regulations

#### Working Party on Passive Safety

#### One-hundred-and-fifty-fifth session

Geneva, 15–18 November 2011

Item 4.8.2 of the provisional agenda

#### 1958 Agreement – Consideration of draft amendments to existing Regulations submitted by GRSP

### **Proposal for Supplement 3 to the 07 series of amendments to Regulation No. 14 (Safety-belt anchorages)**

#### **Submitted by the Working Party on Passive Safety \***

The text reproduced below was adopted by the Working Party on Passive Safety (GRSP) at its forty-ninth session. It is based on ECE/TRANS/WP.29/GRSP/2011/6, as amended by Annex II to the report (ECE/TRANS/WP.29/GRSP/49, para. 17). It is submitted to the World Forum for Harmonization of Vehicle Regulations (WP.29) and to the Administrative Committee (AC.1) for consideration.

---

\* In accordance with the programme of work of the Inland Transport Committee for 2010–2014 (ECE/TRANS/208, para. 106 and ECE/TRANS/2010/8, programme activity 02.4), the World Forum will develop, harmonize and update Regulations in order to enhance the performance of vehicles. The present document is submitted in conformity with that mandate.

## I. Proposal

*Paragraph 1.*, amend to read (including footnote <sup>1</sup>):

### "1. Scope

This Regulation applies to:

- (a) Vehicles of categories M and N <sup>1</sup> with regard to their anchorages for safety-belts intended for adult occupants of forward-facing or rearward-facing or side-facing seats.
- (b) Vehicles of category M<sub>1</sub> ... provisions of this Regulation.

---

<sup>1</sup> As defined in the Consolidated Resolution on the Construction of Vehicles (R.E.3), document ECE/TRANS/WP.29/78/Rev.2, para. 2."

*Insert new paragraphs 2.6.2. to 2.6.4.*, to read:

"2.6.2. "Forward-facing seat" means a seat which can be used while the vehicle is in motion and which faces towards the front of the vehicle in such a manner that the vertical plane of symmetry of the seat forms an angle of less than + 10° or - 10° with the vertical plane of symmetry of the vehicle.

2.6.3. "Rearward-facing seat" means a seat which can be used while the vehicle is in motion and which faces towards the rear of the vehicle in such a manner that the vertical plane of symmetry of the seat forms an angle of less than + 10° or - 10° with the vertical plane of symmetry of the vehicle.

2.6.4. "Side-facing seat" means a seat which can be used while the vehicle is in motion and which faces towards the side of the vehicle in such a manner that the vertical plane of symmetry of the seat forms an angle of 90° (± 10°) with the vertical plane of symmetry of the vehicle."

*Paragraph 5.1.5.*, amend to read:

"5.1.5. The angles  $\alpha_1$  and  $\alpha_2$  are respectively the angles between a horizontal plane through the point H<sub>1</sub> and planes perpendicular to the median vertical longitudinal plane of the seat and passing through the points L<sub>1</sub> and L<sub>2</sub>."

*Paragraph 5.3.2.*, amend to read:

"5.3.2. The minimum number of safety-belt anchorages for each forward, rearward and side-facing seating position shall be those specified in Annex 6."

*Paragraph 5.4.2.5.*, amend to read:

"5.4.2.5. The distance between the two vertical planes parallel to the median vertical longitudinal plane of the vehicle and each passing through a different one of the two effective lower belt anchorages L<sub>1</sub> and L<sub>2</sub> of the same safety-belt shall not be less than 350 mm. In the case of side-facing seats the distance between the two vertical planes parallel to the median vertical longitudinal plane of the seat and each passing through a different one of the two effective lower belt anchorages L<sub>1</sub> and L<sub>2</sub> of the same safety-belt shall not be less than 350 mm. In the case of any central seating positions in rear rows of seats of vehicles of category M<sub>1</sub> and N<sub>1</sub>, the above-mentioned distance shall be not less than 240 mm, provided that it is not possible to exchange the centre rear

seat with any of the other seats of the vehicle. The median longitudinal plane of the seat shall pass between points L<sub>1</sub> and L<sub>2</sub> and shall be at least 120 mm from these points."

*Paragraph 6.3.2., amend to read:*

- "6.3.2. The tractive force shall be applied at an angle of 10 degrees  $\pm$  5° above the horizontal, in a plane parallel to the median longitudinal plane of the vehicle.
- A preload of 10 per cent with a tolerance of  $\pm$  30 per cent of the target load shall be applied; the load shall be increased to 100 per cent of the relevant target load."

*Insert new paragraphs 6.4.7. to 6.4.8.3., to read:*

- "6.4.7. Test in the case of side-facing seats
- 6.4.7.1. The anchorage points shall be tested according to the forces prescribed in paragraph 6.4.3. for M<sub>3</sub> vehicles.
- 6.4.7.2. The test load shall be directed forward in relation to the vehicle, corresponding to the procedure prescribed in paragraph 6.3. In the case that side-facing seats are grouped together on a basic structure, the safety-belt anchorage points of each seating position in the group shall be tested separately. In addition the basic structure has to be tested as described in paragraph 6.4.8.
- 6.4.7.3. Traction device adapted for the test of side-facing seats is shown in Annex 5, figure 1b.
- 6.4.8. Test of the basic structure of side-facing seats
- 6.4.8.1. The basic structure of a side-facing seat or a group of side-facing seats shall be tested according to the forces as prescribed in paragraph 6.4.3. for M<sub>3</sub> vehicles.
- 6.4.8.2. The test load shall be directed forward in relation to the vehicle, corresponding to the procedure prescribed in paragraph 6.3. In the case that side-facing seats are grouped together the basic structure shall be tested simultaneously for each seating position in the group.
- 6.4.8.3. The point of application of the forces prescribed in paragraphs 6.4.3. and 6.4.4. shall be as close as possible to the H-Point and on the line defined by a horizontal plane and a vertical transverse plane through the relevant H-Point of each seating position."

Annex 5, insert a new figure 1b, to read:

"Annex 5

...

Figure 1b

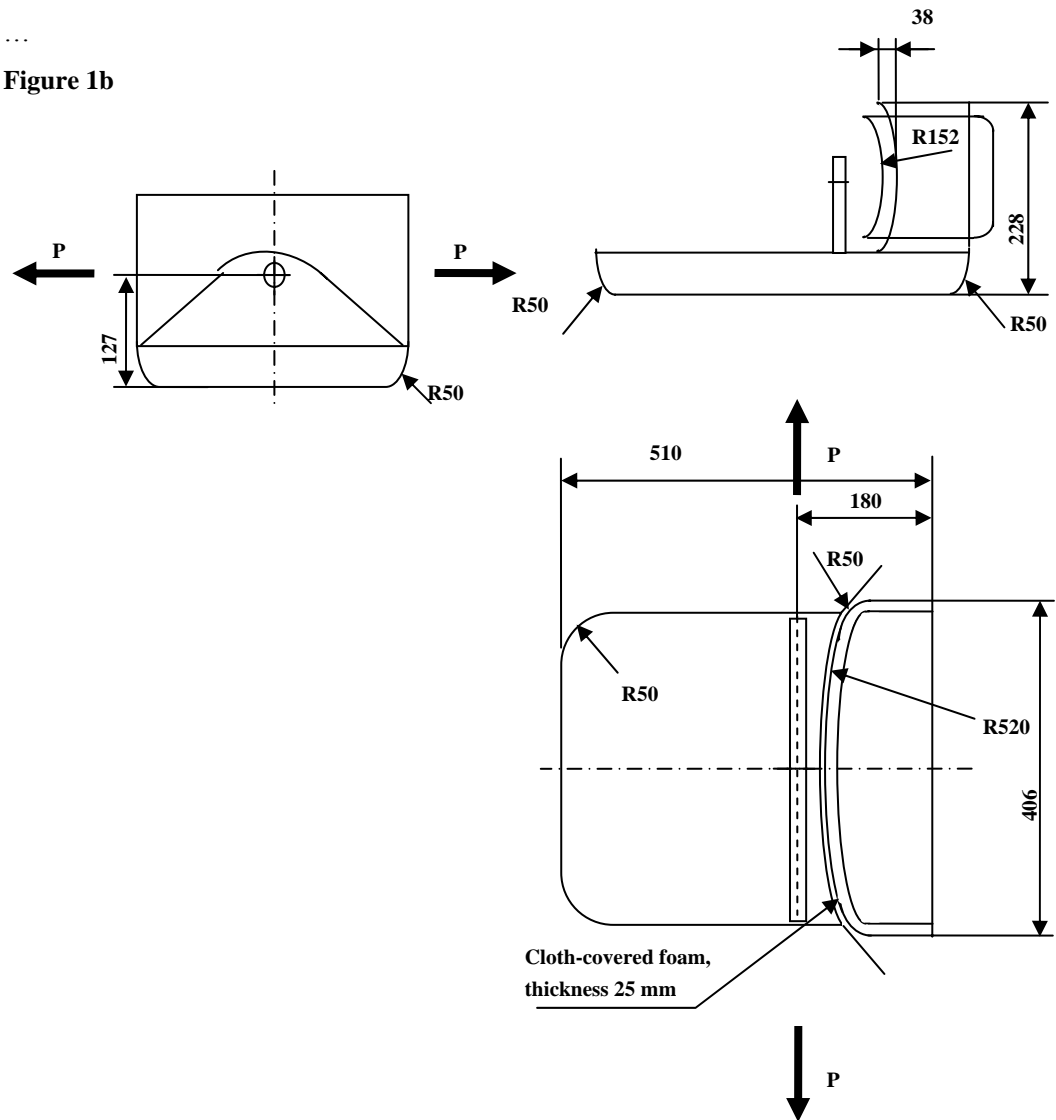

..."

Annex 6, the table, amend to read:

**"Annex 6**

...

<i>Vehicle</i>	<i>Forward facing seating positions</i>				<i>Rearward facing</i>	<i>Side facing</i>
	<i>Outboard</i>		<i>Centre</i>			
<i>Category</i>	<i>Front</i>	<i>Other</i>	<i>Front</i>	<i>Other</i>		
M <sub>1</sub>	3	3	3	3	2	-
M <sub>2</sub> ≤ 3.5 tonnes	3	3	3	3	2	-
M <sub>2</sub> > 3.5 tonnes	3 ⊕	3 or 2 †	3 or 2 †	3 or 2 †	2	-
M <sub>3</sub>	3 ⊕	3 or 2 †	3 or 2 †	3 or 2 †	2	2
N <sub>1</sub>	3	3 or 2 ∅	3 or 2 *	2	2	-
N <sub>2</sub> & N <sub>3</sub>	3	2	3 or 2 *	2	2	-

..."