

Draft agreed during 8th ELSA Meeting**ELECTRICAL SAFETY PROVISIONS FOR VEHICLES IN USE****1. General**

This module shall apply to the electric power train of road vehicles equipped with one or more traction motor(s) operated by electric power and not permanently connected to the grid, **as well as their and the** high voltage components and systems which are **conductively galvanically** connected to the high voltage bus of the electric power train.

~~(This regulation does not cover post crash safety requirements of road vehicles.)~~

2. Definitions

For the purpose of this regulation the following definitions apply:

2-1 “Active driving possible mode”

means the vehicle mode when application of pressure to the accelerator pedal (or activation of an equivalent control) **or release of the brake system** will cause the electric power train to move the vehicle.

2-2 “Barrier”

means the part providing protection against direct contact to the live parts from any direction of access.

2-3 “Conductive connection”

means the connection using contactors to an external power supply when the **rechargeable energy storage system (RESS)** is charged.

2-4 “Coupling system for charging the rechargeable energy storage system (RESS)”

means the electrical circuit used for charging the RESS from an external electric power supply including the vehicle inlet.

2-5 “Direct contact”

means the contact of persons with live parts.

2-6 “Electrical chassis”

means a set made of conductive parts electrically linked together, whose potential is taken as reference.

2-7 “Electrical circuit”

means an assembly of connected live parts which is designed to be electrically energized in normal operation.

2-8 “Electric energy conversion system”

means a system that generates and provides electric energy for electric propulsion.

2-9 “Electric power train”

means the electrical circuit which includes the traction motor(s), and may include the RESS, the electric energy conversion system, the electronic converters, the associated wiring harness and connectors, and the coupling system for charging the RESS.

2-10 “Electronic converter”

means a device capable of controlling and/or converting electric power for electric propulsion.

Draft agreed during 8th ELSA Meeting**2-11 “Enclosure”**

means the part enclosing the internal units and providing protection against direct contact from any direction of access.

2-12 “Exposed conductive part”

means the conductive part which can be touched under the provisions of the protection degree IPXXB, and which becomes electrically energized under isolation-failure conditions.

2-13 “External electric power supply”

means an **alternating current (AC)** or **direct current (DC)** electric power supply outside of the vehicle.

2-14 “High Voltage”

means the classification of an electric component or circuit, if its working voltage is $> 60\text{ V}$ and $\leq 1500\text{ V}$ **direct-current (DC)** or $> 30\text{ V}$ and $\leq 1000\text{ V}$ **alternating-current (AC)** root mean square (rms).

2-15 “High Voltage Bus”

means the electrical circuit, including the coupling system for charging the RESS that operates on high voltage.

2-16 “Indirect contact”

means the contact of persons with exposed conductive parts.

2-17 “Live parts”

means the conductive part(s) intended to be electrically energized in normal use.

2-18 “Luggage compartment”

means the space in the vehicle for luggage accommodation, bounded by the roof, hood, floor, side walls, as well as by the barrier and enclosure provided for protecting the power train from direct contact with live parts, being separated from the passenger compartment by the front bulkhead or the rear bulk head.

2-19 “On-board isolation resistance monitoring system”

means the device which monitors the isolation resistance between the high voltage buses and the electrical chassis.

2-20 “Open type traction battery”

means a liquid type battery requiring refilling with water and generating hydrogen gas released to the atmosphere.

2-21 “Passenger compartment”

means the space for occupant accommodation, bounded by the roof, floor, side walls, doors, window glass, front bulkhead and rear bulkhead, or rear gate, as well as by the barriers and enclosures provided for protecting the power train from direct contact with live parts.

2-22 “Protection degree”

means the protection provided by a barrier/enclosure related to the contact with live parts by a test probe, such as a test finger (IPXXB) or a test wire (IPXXD), as defined in Attached Sheet 3.

2-23 “Rechargeable energy storage system (RESS)”

means the rechargeable energy storage system that provides electric energy for electric propulsion.

Draft agreed during 8th ELSA Meeting

2-24 "Service disconnect"

means the device for deactivation of the electrical circuit when conducting checks and services of the RESS, fuel cell stack, etc.

2-25 "Solid insulator"

means the insulating coating of wiring harnesses provided in order to cover and protect the live parts against direct contact from any direction of access; covers for insulating the live parts of connectors, and varnish or paint for the purpose of insulation.

2-26 "Working voltage"

means the highest value of an electrical circuit voltage root mean square (rms), specified by the manufacturer **or determined by measurement**, which may occur between any conductive parts in open circuit conditions or under normal operating condition. If the electrical circuit is divided by galvanic isolation, the working voltage is defined for each divided circuit, respectively.

3 Requirements for Protection against Electrical Shock

3-0 Protection against electric shock

These electrical safety requirements apply to high voltage buses under conditions where they are not connected to external high voltage power supplies.

3-1 Protection against direct contact

The protection against direct contact with live parts shall comply with paragraphs 3-12-1 and 3-1-2. These protections (solid insulator, barrier, enclosure, etc.) shall not be able to be opened, disassembled or removed without the use of tools.

3-1-1

For protection of live parts inside the passenger compartment or luggage compartment, the protection degree IPXXD shall be provided.

3-1-2

For protection of live parts in areas other than the passenger compartment or luggage compartment, the protection degree IPXXB shall be satisfied.

3-1-3 Connectors

Connectors (including vehicle inlet) are deemed to meet this requirement if:

- a) they comply with 3-1-1 and 3-1-2 when separated without the use of tools or
- b) they are located underneath the floor and are provided with a locking mechanism or
- c) they are provided with a locking mechanism and other components **shall must** be removed with the use of tools in order to separate the connector or
- d) the voltage of the live parts becomes equal or below DC 60V or equal or below AC 30V (rms) within 1 second after the connector is separated

3-1-4 Service disconnect

For a service disconnect which can be opened, disassembled or removed without tools, it is acceptable if protection degree IPXXB is satisfied under a condition where it is opened, disassembled or removed without tools.

3-1-5 Marking

3-1-5-1 The symbol shown in Figure 1 shall appear on or near the RESS. The symbol background shall be yellow, the bordering and the arrow shall be black.

Draft agreed during 8th ELSA Meeting

Figure 1 — Marking of high voltage equipment

3-1-5-2 The ~~same~~ symbol shall be visible on enclosures and barriers, which, when removed expose live parts of high voltage circuits. This provision ~~is optional shall not apply~~ to any connectors for high voltage buses. ~~However~~, This provision shall not apply to any of the following cases

- a) where barriers or enclosures cannot be **physically** accessed, **opened, or removed**; unless other vehicle components are removed with the use of tools.
- b) where barriers or enclosures are located underneath the vehicle floor

~~3-1-5-3 The outer covering of cables and harness for high voltage buses, not within enclosures or not underneath the vehicle floor shall be identified by orange color.~~

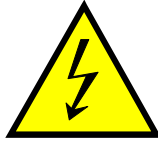
Cables for high voltage buses which are not located within enclosures shall be identified by having an outer covering with the colour orange.

3-2 Protection against indirect contact

3-2-1 For protection against electrical shock which could arise from indirect contact, the exposed conductive parts, such as the conductive barrier and enclosure, shall be conductively **galvanically** connected securely to the electrical chassis by connection with electrical wire or ground cable, or by welding, or by connection using bolts, etc. so that no dangerous potentials are produced.

3-2-2 The resistance between all exposed conductive parts and the electrical chassis shall be lower than 0.1 ohm when there is current flow of at least 0.2 amperes. **Demonstrated by using one of the test procedures described in Attached Sheet 04.**

This requirement is satisfied if the galvanic connection has been established by welding. **In case of doubts a measurement shall be made.**

3-2-3 In the case of motor vehicles which are connected to the grounded external electric power supply through the conductive connection, a device to enable the conductive **galvanical** connection of the electrical chassis to the earth ground shall be provided.

The device **shall** enable connection to the earth ground before exterior voltage is applied to the vehicle and retain the connection until after the exterior voltage is removed from the vehicle.

Compliance to this requirement may be demonstrated either by using the connector specified by the car manufacturer, or by analysis (**e.g. visual inspection, drawings etc.**).

3-3 Isolation Resistance

3-3-1 Electric power train consisting of separate **Direct Current DC-** or **Alternating Current AC-**buses

If AC high voltage buses and DC high voltage buses are **galvanically conductively** isolated from each other, isolation resistance between the high voltage bus and the electrical

Draft agreed during 8th ELSA Meeting

chassis shall have a minimum value of 100 ohms/volt of the working voltage for DC buses, and a minimum value of 500 ohms/volt of the working voltage for AC buses.

The measurement shall be conducted according to Attached Sheet 1 "Isolation Resistance Measurement Method" ~~or a method equivalent to it.~~

3-3-2 Electric power train consisting of combined DC- and AC-buses

If AC high voltage buses and DC high voltage buses are conductive galvanically connected isolation resistance between the high voltage bus and the electrical chassis shall have a minimum value of 500 ohms/volt of the working voltage.

~~However, if all AC high voltage buses are protected by one of the 2 following measures, isolation resistance between the high voltage bus and the electrical chassis shall have a minimum value of 100 ohms/volt of the working voltage.~~

~~a) —double or more layers of solid insulators, barriers or enclosures that meet the requirement in paragraph 3-2 independently, for example wiring harness;~~

~~b) —mechanically robust protections that have sufficient durability over vehicle service life such as motor housings, electronic converter cases or connectors;~~

The isolation resistance between the high voltage bus and the electrical chassis may be demonstrated by measurement or a combination of measurement and calculation.

The measurement shall be conducted according to Attached Sheet 1 "Isolation Resistance Measurement Method" ~~or a method equivalent to it.~~

3-3-3 Fuel cell vehicles

3-3-3-1 In fuel cell vehicles, DC high voltage buses shall have an on-board isolation resistance monitoring system together with a warning to the driver if the isolation resistance drops below the minimum required value of 100 ohms/volt.

The function of the on-board isolation resistance monitoring system shall be confirmed as described in Attached Sheet 2.

The isolation resistance between the high voltage bus of the coupling system for charging the RESS, which is not energized in conditions other than that during the charging of the RESS, and the electrical chassis need not to be monitored.

Draft agreed during 8th ELSA Meeting

3-3-3-2 Electric power train consisting of combined DC- and AC-buses

However, if all AC high voltage buses are protected by one of the 2 following measures, isolation resistance between the high voltage bus and the electrical chassis shall have a minimum value of 100 ohms/volt of the working voltage.

- a) double or more layers of solid insulators, barriers or enclosures that meet the requirement in paragraph 3.2 independently, for example wiring harness;
- b) mechanically robust protections that have sufficient durability over vehicle service life such as motor housings, electronic converter cases or connectors.

Comment: OICA has to come up with a proposal for a) and b) that allows NTHSA to tell the manufacturer how the system has to be tested.

3-3-4 Isolation resistance requirement for the coupling system for charging the RESS

For the vehicle inlet intended to be conductively connected to the grounded external AC power supply and the electrical circuit that is conductively ~~galvanically~~ connected to the vehicle inlet during charging the RESS, the isolation resistance between the high voltage bus and the electrical chassis shall be at least 1M ohms when the charger coupler is disconnected. During the measurement, the ~~traction battery~~ **RESS** may be disconnected.

The measurement shall be conducted according to Attached Sheet 1 "Isolation Resistance Measurement Method"

4. **Rechargeable energy storage system Requirements for (RESS)**

The following requirements are applicable for Contracting Parties under the type-approval system.

4-1 **Protection against excessive current**

The RESS shall not overheat.

If the RESS is subject to overheating due to excessive current, it shall be equipped with a protective device such as fuses, circuit breakers or main contactors.

However, the requirement may not apply if the manufacturer supplies data that ensures overheating from excessive current is prevented without the protective device.

4-2 Accumulation of Gas

Places for containing open type traction battery that may produce hydrogen gas shall be provided with a ventilation fan or a ventilation duct to prevent the accumulation of hydrogen gas.

5. **Requirements for Functional Safety**

At least a momentary indication shall be given to the driver when the vehicle is in "active driving possible mode".

However, this provision does not apply under conditions where an internal combustion engine provides directly or indirectly the vehicle's propulsion power **upon start up**.

When leaving the vehicle, the driver shall be informed by a signal (e.g. optical or audible signal) if the vehicle is still in the active driving possible mode.

Draft agreed during 8th ELSA Meeting

If the on-board RESS can be externally charged ~~by the user~~, vehicle movement by its own propulsion system shall be impossible as long as the connector of the external electric power supply is physically connected to the vehicle inlet.

This requirement shall be demonstrated by using the connector specified by the car manufacturer.

The state of the drive direction control unit shall be identified to the driver

Draft agreed during 8th ELSA Meeting

Attached Sheet 1

ISOLATION RESISTANCE MEASUREMENT METHOD

1. General

The isolation resistance for each high voltage bus of the vehicle shall be measured or shall be determined by calculation using measurement values from each part or component unit of a high voltage bus (hereinafter referred to as the “divided measurement”).

2. Measurement Method

The isolation resistance measurement shall be conducted by selecting an appropriate measurement method from among those listed in Paragraphs 2–1 through 2–2, depending on the electrical charge of the live parts or the isolation resistance, etc.

The range of the electrical circuit to be measured shall be clarified in advance, using electrical circuit diagrams, etc.

Moreover, modification necessary for measuring the isolation resistance may be carried out, such as removal of the cover in order to reach the live parts, drawing of measurement lines, change in software, etc.

In cases where the measured values are not stable due to the operation of the on-board isolation resistance monitoring system, **etc.**, necessary modification for conducting the measurement may be carried out, such as stopping of the operation of the device concerned or removing it. Furthermore, when the device is removed, it must be proven, using drawings, etc., that it will not change the isolation resistance between the live parts and the electrical chassis.

Utmost care must be exercised as to short circuit, electric shock, etc., for this confirmation might require direct operations of the high-voltage circuit.

2–1 Measurement method using DC voltage from off-vehicle sources

2–1–1 Measurement instrument

An isolation resistance test instrument capable of applying a DC voltage higher than the working voltage of the high voltage bus shall be used.

2–1–2 Measurement method

An insulator resistance test instrument shall be connected between the live parts and the electrical chassis. Then, the isolation resistance shall be measured by applying a DC voltage at least half of the working voltage of the high voltage bus.

If the system has several voltage ranges (e.g. because of boost converter) in conductive **galvanically** connected circuit and some of the components can not withstand the working voltage of the entire circuit, the isolation resistance between those components and the electrical chassis can be measured separately by applying their own working voltage with those component disconnected.

2–2 Measurement method using the vehicle’s own RESS as DC voltage source

2–2–1 Test vehicle conditions

The high voltage-bus shall be energized by the vehicle’s own RESS and/or energy conversion system and the voltage level of the RESS and/or energy conversion system throughout the test shall be at least the nominal operating voltage as specified by the vehicle manufacturer.

Draft agreed during 8th ELSA Meeting

2-2-2 Measurement instrument

The voltmeter used in this test shall measure DC values and shall have an internal resistance of at least 10 M Ω .

2-2-3 Measurement method

2-2-3-1 First step

The voltage is measured as shown in Figure 1 and the high voltage Bus voltage (V_b) is recorded. V_b shall be equal to or greater than the nominal operating voltage of the RESS and/or energy conversion system as specified by the vehicle manufacturer.

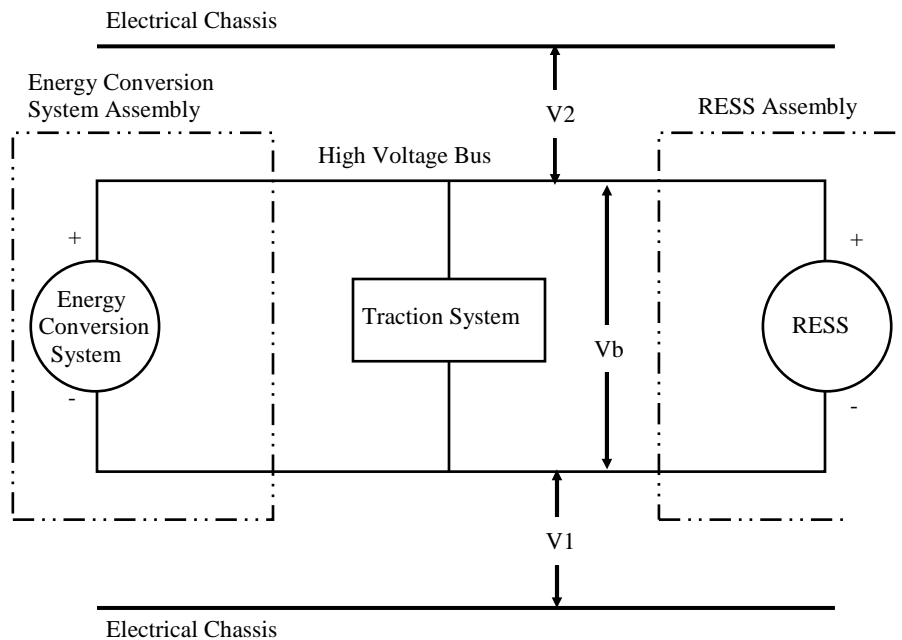

Figure 1: Measurement of V_b , V_1 , V_2

2-2-3-2 Second step

Measure and record the voltage (V_1) between the negative side of the high voltage bus and the electrical chassis (see Figure 1):

2-2-3-3 Third step

Measure and record the voltage (V_2) between the positive side of the high voltage bus and the electrical chassis (see Figure 1):

2-2-3-4 Fourth step

If V_1 is greater than or equal to V_2 , insert a standard known resistance (R_o) between the negative side of the high voltage bus and the electrical chassis. With R_o installed, measure the voltage (V_1') between the negative side of the high voltage bus and the electrical chassis (see Figure 2).

Draft agreed during 8th ELSA Meeting

Calculate the electrical isolation (Ri) according to the following formula:

$$Ri = Ro * (Vb/V1' - Vb/V1) \text{ or } Ri = Ro * Vb * (1/V1' - 1/V1)$$

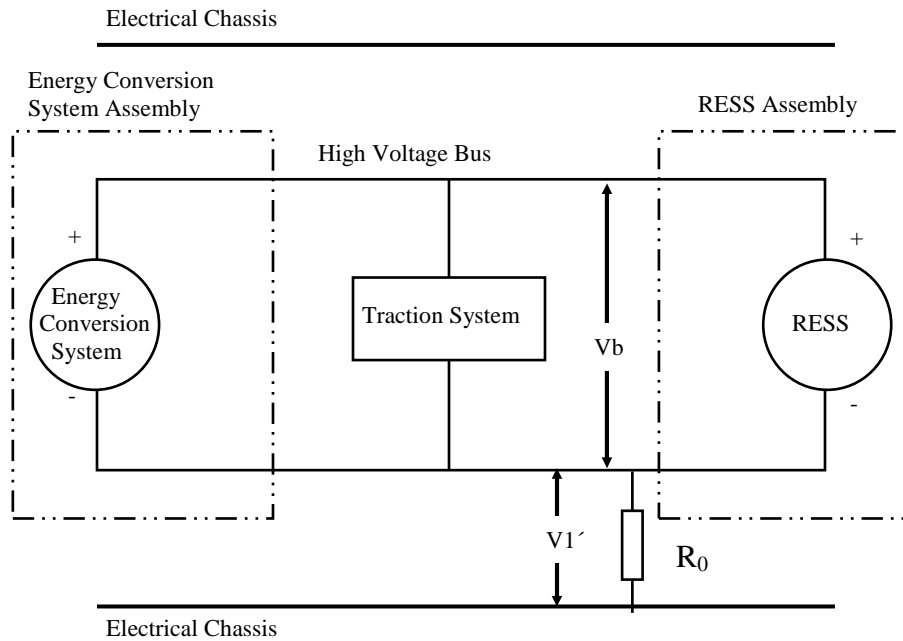

Figure 2: Measurement of V1'

If V2 is greater than V1, insert a standard known resistance (Ro) between the positive side of the high voltage bus and the electrical chassis. With Ro installed, measure the voltage (V2') between the positive side of the high voltage bus and the electrical chassis. (See Figure 3). Calculate the electrical isolation (Ri) according to the formula shown. Divide this electrical isolation value (in ohms) by the nominal operating voltage of the high voltage bus (in volts).

Calculate the electrical isolation (Ri) according to the following formula:

$$Ri = Ro * (Vb/V2' - Vb/V2) \text{ or } Ri = Ro * Vb * (1/V2' - 1/V2)$$

Draft agreed during 8th ELSA Meeting

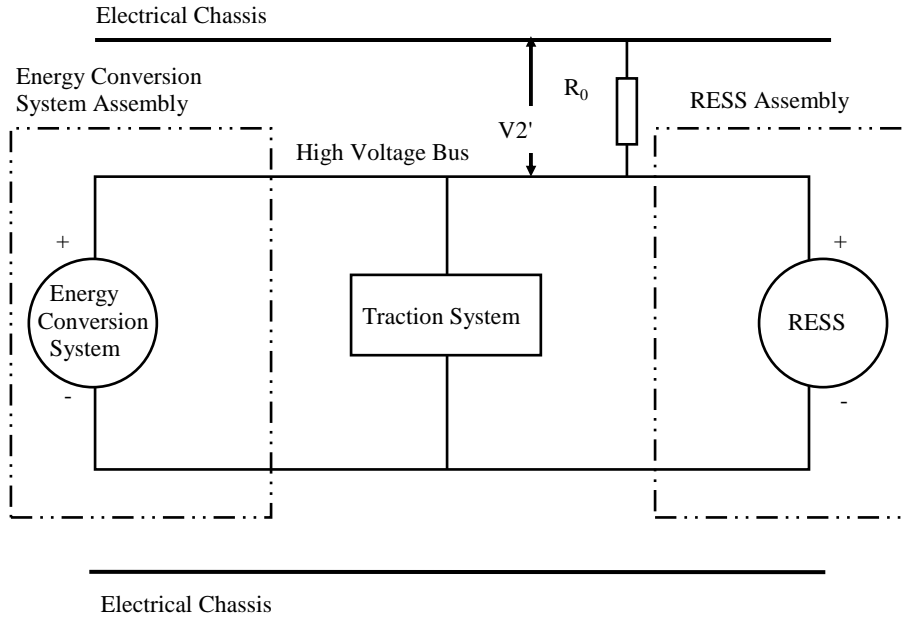

Figure 3: Measurement of $V2'$

2-2-3-5 Fifth step

The electrical isolation value R_i (in ohms) divided by the working voltage of the high voltage bus (in volts) results in the isolation resistance (in ohms/volt).

(NOTE 1: The standard known resistance R_0 (in ohms) should be the value of the minimum required isolation resistance (in ohms/V) multiplied by the working voltage of the vehicle plus/minus 20% (in volts). R_0 is not required to be precisely this value since the equations are valid for any R_0 ; however, a R_0 value in this range should provide good resolution for the voltage measurements.)

Draft agreed during 8th ELSA Meeting

Attached Sheet 2

Confirmation Method for Functions of On-board Isolation Resistance Monitoring System

The function of the on-board isolation resistance monitoring system shall be confirmed by the following method or a method equivalent to it.

Insert a resistor that does not cause the isolation resistance between the terminal being monitored and the electrical chassis to drop below the minimum required isolation resistance value. The warning shall be activated.

Draft agreed during 8th ELSA Meeting

Attached Sheet 3

PROTECTION AGAINST DIRECT CONTACTS OF PARTS UNDER VOLTAGE**1. Access probes**

Access probes to verify the protection of persons against access to live parts are given in table 1.

2. Test conditions

The access probe is pushed against any openings of the enclosure with the force specified in table 1. If it partly or fully penetrates, it is placed in every possible position, but in no case shall the stop face fully penetrate through the opening.

Internal barriers are considered part of the enclosure.

A low-voltage supply (of not less than 40 V and not more than 50 V) in series with a suitable lamp should be connected, if necessary, between the probe and live parts inside the barrier or enclosure.

The signal-circuit method should also be applied to the moving live parts of high voltage equipment.

Internal moving parts may be operated slowly, where this is possible.

3. Acceptance conditions

The access probe shall not touch live parts.

If this requirement is verified by a signal circuit between the probe and live parts, the lamp shall not light.

In the case of the test for IPXXB, the jointed test finger may penetrate to its 80 mm length, but the stop face (diameter 50 mm x 20 mm) shall not pass through the opening. Starting from the straight position, both joints of the test finger shall be successively bent through an angle of up to 90 degree with respect to the axis of the adjoining section of the finger and shall be placed in every possible position.

In case of the tests for IPXXD, the access probe may penetrate to its full length, but the stop face shall not fully penetrate through the opening

Draft agreed during 8th ELSA Meeting

Table 1 - Access probes for the tests for protection of persons against access to hazardous parts

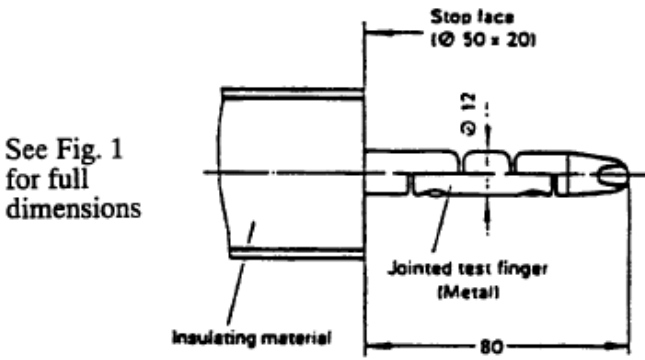
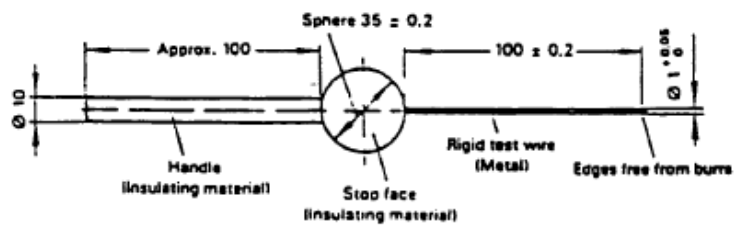
First numeral	Addit. letter	Access probe	Test force
2	B	<p style="text-align: center;">Jointed test finger</p>  <p>See Fig. 1 for full dimensions</p>	10N+/-10%
4.5.6	D	<p style="text-align: center;">Test wire 1.0 mm diameter 100 mm long</p> 	1N+/-10%

Draft agreed during 8th ELSA Meeting

Figure 1 - Jointed test finger

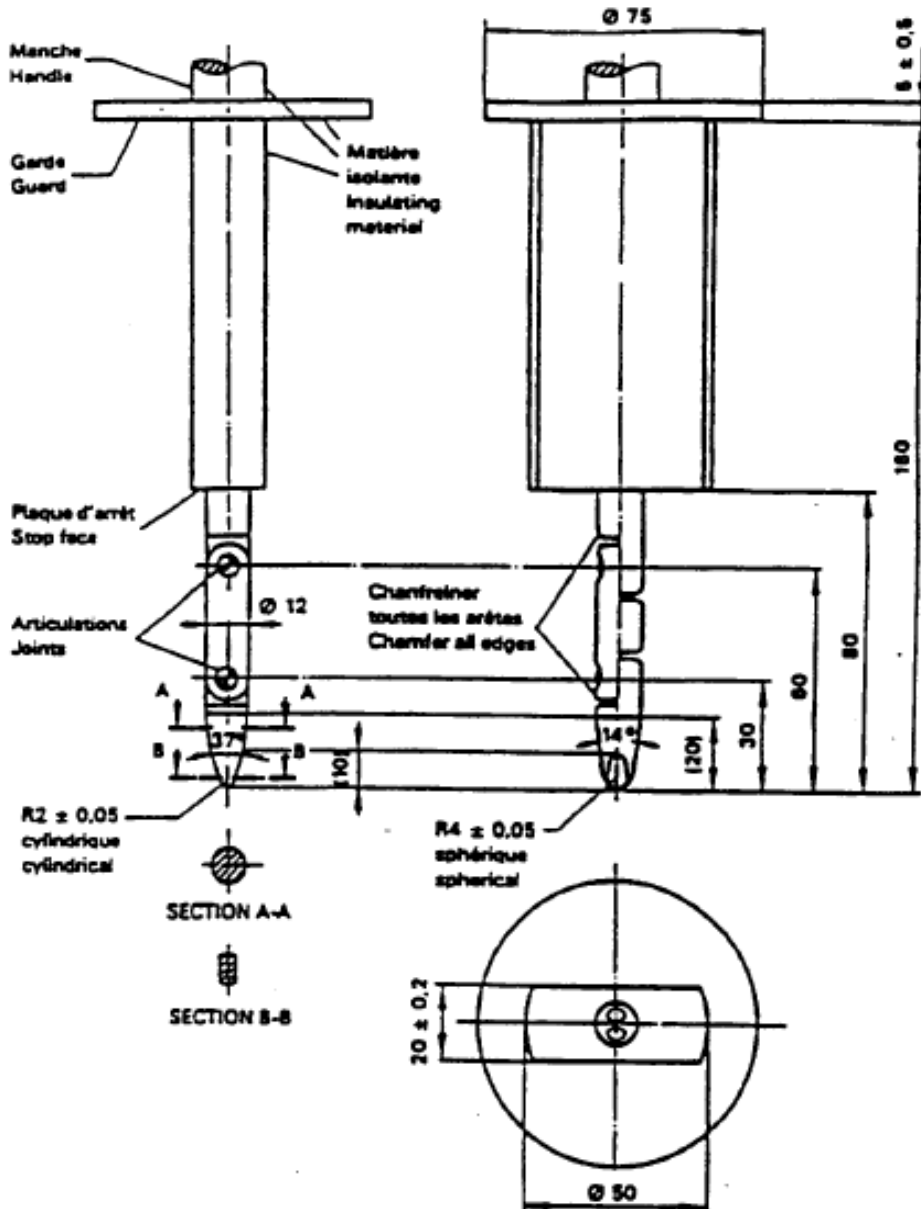

Material: metal, except where otherwise specified

Linear dimensions in millimeters

Tolerances on dimensions without specific tolerance:

on angles, 0/-10'

on linear dimensions:

up to 25 mm: 0/-0.05

over 25 mm: +/- 0.2

Both joints shall permit movement in the same plane and the same direction through an angle of 90° with a 0 to +10° tolerance.

Draft agreed during 8th ELSA Meeting

Attached Sheet 04

Test method for measuring electric resistance**A) Test method using a resistance tester**

Connect the resistance tester to the measuring points (Typically, electrical chassis and electroconductive enclosure/barrier) and measure the resistance using a resistance tester that meets the specification that follows.

Resistance tester: Measurement current at least 0.2 A
Resolution 0.01 Ω or less

The resistance R shall be less than 0.1 ohm.

B) Test method using D.C. power supply, voltmeter and ammeter.

Example of the test method using D.C. power supply, voltmeter and ammeter is shown below.

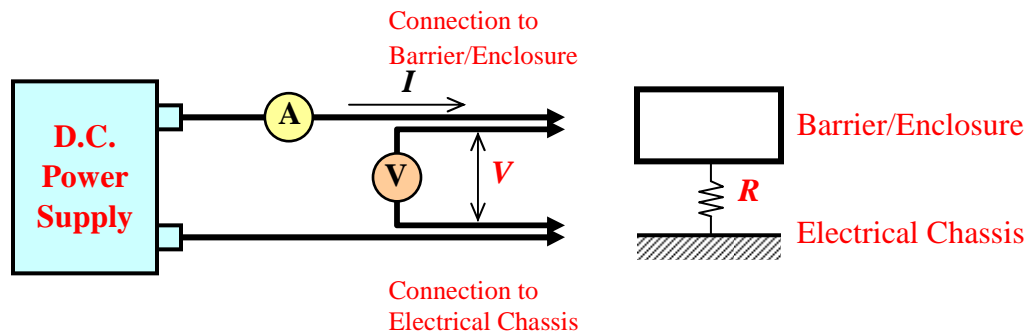
**Test Procedure**

- Connect the D.C. power supply, voltmeter and ammeter to the measuring points (Typically, electrical chassis and electroconductive enclosure/barrier).
- Adjust the voltage of the D.C. power supply so that the current flow becomes more than 0.2 A.
- Measure the current " I " and the voltage " V ".
- Calculate the resistance " R " according to the following formula:
 $R = V / I$

The resistance R shall be less than 0.1 ohm.

Note: In case lead wires are used for voltage and current measurement, each lead wire shall be independently connected to the barrier/enclosure/electrical chassis. Terminal can be common for voltage measurement and current measurement.

Draft agreed during 8th ELSA Meeting

