



Economic and Social Council

Distr.: General
23 July 2010

Original: English
English and French only

Economic Commission for Europe

Inland Transport Committee

World Forum for Harmonization of Vehicle Regulations

Working Party on Lighting and Light-Signalling

Sixty-fourth session

Geneva, 4–7 October 2010

Item 15 of the provisional agenda

Regulation No. 99 (Gas-discharge light sources)

Proposal for Supplement 7 to Regulation No. 99

Submitted by the experts from the Working Party “Brussels 1952”*

The text reproduced below was prepared by the expert from Working Party “Brussels 1952” (GTB) in order to introduce new categories of gas discharge light sources D5S and D6S in this regulation. The modifications to the existing text of the Regulation are marked in bold for new characters.

* In accordance with the programme of work of the Inland Transport Committee for 2006–2010 (ECE/TRANS/166/Add.1, programme activity 02.4), the World Forum will develop, harmonize and update Regulations in order to enhance the performance of vehicles. The present document is submitted in conformity with that mandate.

I. Proposal

Paragraph 2.2.2.2., amend to read:

“2.2.2.2. a technical description including, **if the ballast is not integrated with the light source**, ballast identification;”

Paragraph 2.2.2.4., amend to read:

“2.2.2.4. one sample of the ballast **in case the ballast is not integrated with the light source.**”

Paragraph 2.3.4., amend to read:

“2.3.4. **In case the ballast is not integrated with the light source**, the ballast used for the type approval of the light source shall be marked with type and trade mark identification and with the rated voltage and wattage, as indicated on the relevant lamp data sheet.”

Paragraph 2.4.1., amend to read:

“2.4.1. If all samples of a type of gas-discharge light source which are submitted in accordance with paragraphs 2.2.2.3. or 2.2.3.2. comply with the requirements of this Regulation, **when** tested with the ballast according to paragraph 2.2.2.4. **in case the ballast is not integrated with the light source**, approval shall be granted.”

Paragraph 3.1.2., amend to read:

“3.1.2. “*Ballast*”: Specific electrical supply for the gas-discharge light source, **possibly integrated with the light source.**”

Paragraph 3.1.3., amend to read:

“3.1.3. “*Rated voltage*”: Input voltage marked on the ballast **or on the light source in the case that the ballast is integrated with the light source.**”

Paragraph 3.1.5., amend to read:

“3.1.5. “*Test voltage*”: Voltage, at the input terminals of the ballast **or at the terminals of the light source in the case that the ballast is integrated with the light source**, for which the electrical and photometric characteristics of the gas-discharge light source are intended and are to be tested.”

Paragraph 3.1.6., amend to read:

“3.1.6. “*Objective value*”: Design value of an electrical or photometric characteristic. To be achieved, within the specified tolerances, when the gas-discharge light source is energized by the ballast, **possibly integrated with the light source, and** operated at test voltage.”

Paragraph 3.2.1., amend to read:

“3.2.1. Each sample submitted shall conform to the relevant specifications of this Regulation when tested, **in the case the ballast is not integrated with the light source** with the ballast according to paragraph 2.2.2.4.”

Paragraph 3.3.2., amend to read:

“3.3.2. In the case of a coloured (outer) bulb, after an operating period of 15 hours with the ballast **or the light source with the ballast integrated** at test

voltage, the surface of the bulb shall be lightly wiped with a cotton cloth soaked in a mixture of 70 volume per cent of n-heptane and 30 volume per cent of toluol. After about five minutes, the surface shall be inspected visually. It shall not show any apparent changes.”

Paragraph 3.4.2., amend to read:

“3.4.2. All samples shall be tested with the ballast, according to paragraph 2.2.2.4., **in case the ballast is not integrated with the light source.**”

Paragraph 3.5.2.1., amend to read:

“3.5.2.1. The measurement shall be made after ageing with the light source supplied by the ballast at test voltage **or the light source with the ballast integrated at test voltage.**”

Paragraph 3.5.3.1., amend to read:

“3.5.3.1. The measurement shall be made after ageing with the light source supplied by the ballast at test voltage **or the light source with the ballast integrated at test voltage.**”

Paragraph 3.6.2., amend to read:

“3.6.2. Run-up

3.6.2.1. For gas-discharge light sources having an objective luminous flux which exceeds 2000 lm:

When measured according to the conditions specified in Annex 4, the gas-discharge light source shall emit at least:

After 1 second: 25 per cent of its objective luminous flux;

After 4 seconds: 80 per cent of its objective luminous flux.

The objective luminous flux as indicated on the relevant data sheet.

3.6.2.2. For gas-discharge light sources having an objective luminous flux which does not exceed 2000 lm:

When measured according to the conditions specified in Annex 4, the gas-discharge light sources shall emit at least 800 lm after 1 second and at least 1000 lm after 4 seconds.

The objective luminous flux as indicated on the relevant data sheet.”

Annex 1, list of categories of gas-discharge light sources and their sheet numbers, amend to read:

“

<i>Light source category</i>	<i>Sheet numbers</i>
D1R	DxR/1 to 7
D1S	DxS/1 to 6
D2R	DxR/1 to 7
D2S	DxS/1 to 6
D3R	DxR/1 to 7
D3S	DxS/1 to 6
D4R	DxR/1 to 7
D4S	DxS/1 to 6
D5S	D5S/1 to 5
D6S	D6S/1 to 5

”

Annex 1, list of sheets for gas-discharge light sources and their sequence in this annex, amend to read:

“

<i>Sheet numbers</i>	
DxR/1 to 7	(Sheet DxR/6: two pages)
DxS/1 to 6	
D5S/1 to 5	
D6S/1 to 5	

”

Insert new sheets D5S/1 to 5, to read:

“

CATEGORY D5S

Sheet D5S/1

The drawings are intended only to illustrate the essential dimensions (in mm) of the gas-discharge light source

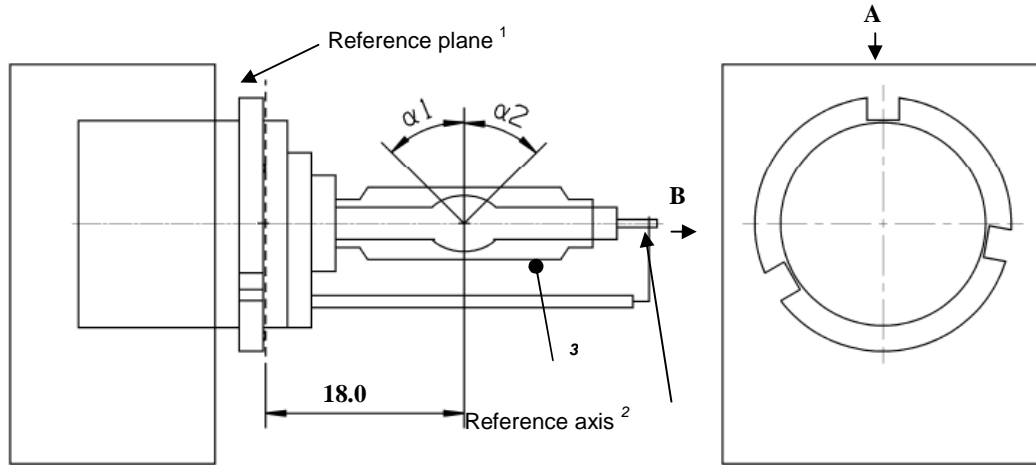

Figure 1 - Category D5S - Cap PK32d-[7]

- 1 The reference plane is defined by the positions on the surface of the holder on which the three supporting bosses of the cap ring will rest.
- 2 See sheet D5S/2.
- 3 When measured at a distance of 18.0 mm from the reference plane and with respect to the mid-point of the inner bulb, the outer bulb shall have an eccentricity of 1 mm max.

Figure 2
 Definition of reference axis¹
 The cap shall be pushed in this direction

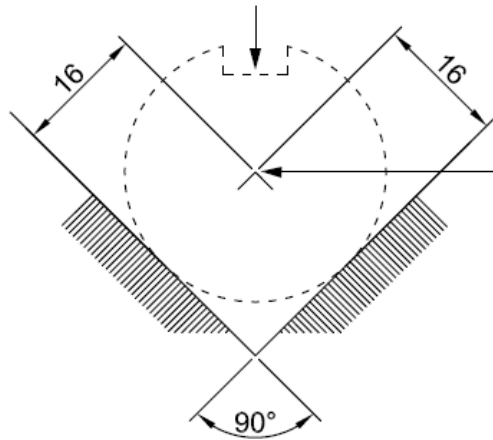
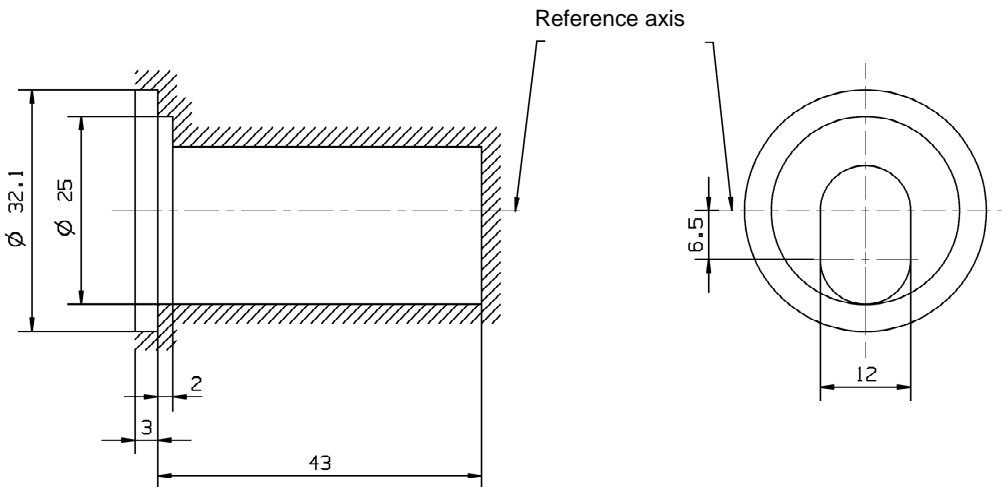

Figure 3
 Maximum lamp outline²



¹ The reference axis is perpendicular to the reference plane and crosses the intersection of the two parallel lines as indicated in figure 2.

² Glass bulb and supports shall not exceed the envelope, as indicated in figure 3. The envelope is concentric with the reference axis.

CATEGORY D5S

Sheet D5S/3

<i>Dimensions</i>		<i>Production light sources</i>	<i>Standard light sources</i>	
Position of the electrodes		Sheet D5S/4		
Position and form of the arc		Sheet D5S/5		
$\alpha 1, \alpha 2$ ¹		55° min.	55° min.	
D5S: Cap PK32d-7 in accordance with IEC Publication 60061 (sheet 7004-111-[4])				
ELECTRICAL AND PHOTOMETRIC CHARACTERISTICS				
Rated voltage	V	12 / 24	12 / 24	
Rated wattage	W	25	25	
Test voltage	V	13,2 / 28	13,2 / 28	
Objective lamp wattage ²	W	31 max.	31 max.	
Chromaticity coordinates	Objective	x = 0.375	y = 0.375	
	Tolerance area ³	Boundaries	x = 0.345	y = 0.150 + 0.640 x
			x = 0.405	y = 0.050 + 0.750 x
		Intersection points	x = 0.345	y = 0.371
			x = 0.405	y = 0.409
			x = 0.405	y = 0.354
x = 0.345	y = 0.309			
Objective Luminous flux	lm	2000 ± 300	2000 ± 100	
Hot-restrike switch-off time	s	10	10	

¹ The part of the bulb within the angles $\alpha 1$ and $\alpha 2$ shall be the light emitting part. This part shall be as homogeneous in form as possible and shall be optically distortion free. This applies to the whole bulb circumference within the angles $\alpha 1$ and $\alpha 2$.

² Wattage of lamp with ballast integrated.

³ See Annex 4.

Position of the electrodes

This test is used to determine whether the electrodes are correctly positioned relative to the reference axis and the reference plane.

Top view (schematic):

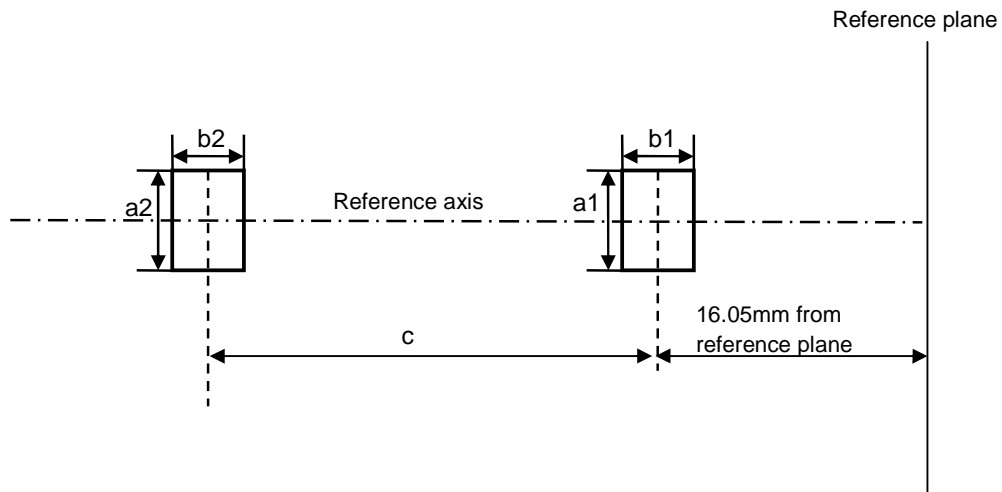

Side view (schematic):

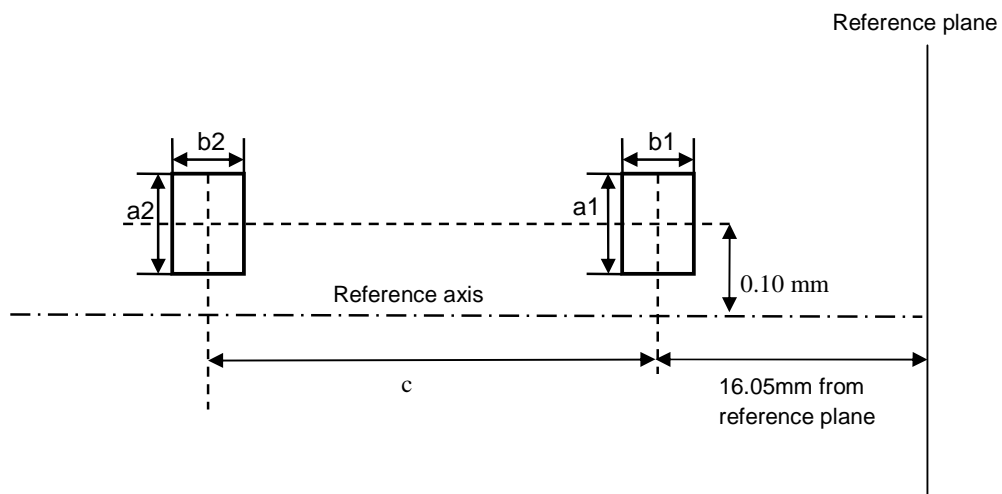

Measuring direction: light source side and top view

Dimension in mm	Production light sources	Standard light sources
a1	0.30	0.20
a2	0.50	0.25
b1	0.30	0.15
b2	0.60	0.30
c	3.90	3.90

The arc attachment point to the electrode nearest to the reference plane shall be positioned in the area defined by a1 and b1. The arc attachment point to the electrode furthest from the reference plane shall be positioned in the area defined by a2 and b2.

Position and form of the arc

This test is used to determine the form of the arc and its position relative to the reference axis and the reference plane by measuring its bending and diffusion in the cross section at a distance 18.0 mm from the reference plane.

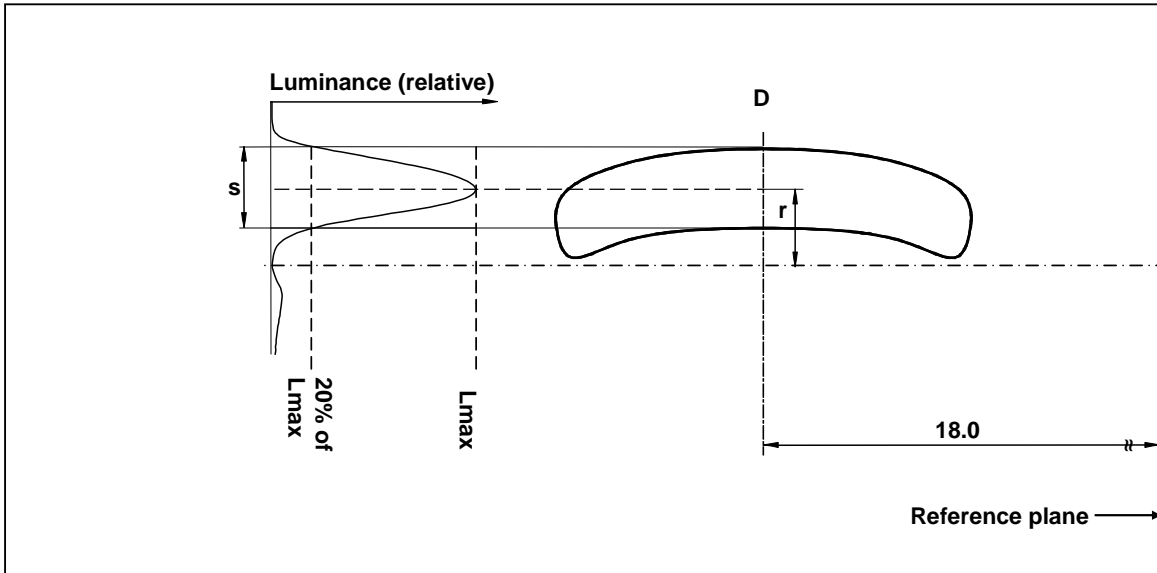

Relative luminance distribution in the central cross section D. The form of the arc is for illustration purpose only.

Measuring direction: light source side view

When measuring the relative luminance distribution in the central cross section as indicated in the drawing above, the maximum value shall be located within the distance r from the reference axis. The point of 20 per cent of the maximum value shall be within s .

<i>Dimension in mm</i>	<i>Production light sources</i>	<i>Standard light sources</i>
r (arc bending)	0.50 +/-0.25	0.50 +/-0.15
s (arc diffusion)	0.70 +/-0.25	0.70 +/-0.15

”

Insert new sheets D6S/1 to 5, after sheet DxS/6, to read:

“

CATEGORY D6S

Sheet D6S/1

The drawings are intended only to illustrate the essential dimensions (in mm) of the gas-discharge light source

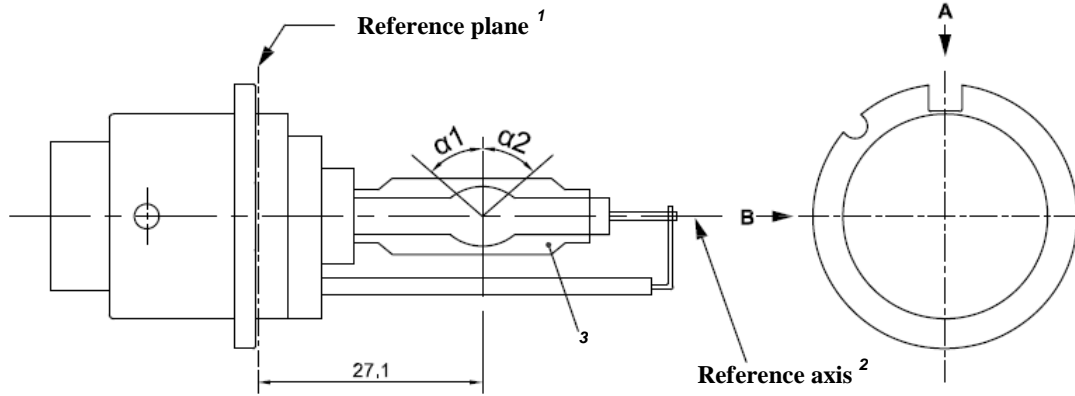

Figure 1
Category D6S - Cap P32d-1

¹ The reference plane is defined by the positions on the surface of the holder on which the three supporting bosses of the cap ring will rest.

² See sheet D6S/2.

³ When measured at a distance of 27.1 mm from the reference plane and with respect to the mid-point of the inner bulb, the outer bulb shall have an eccentricity of 1 mm max.

CATEGORY D6S

Sheet D6S/2

Figure 2
Definition of reference axis ¹

The cap shall be pushed in this direction

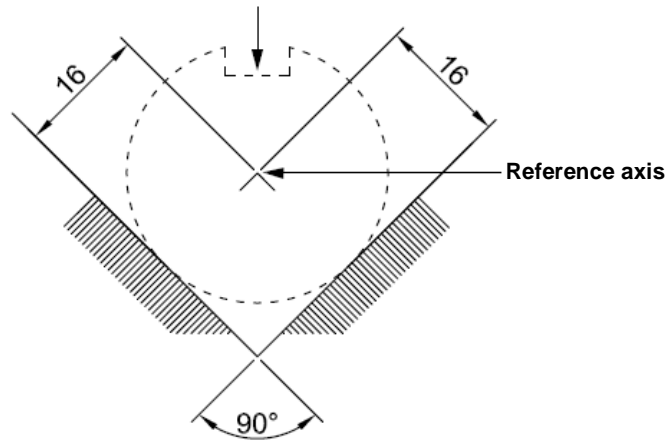
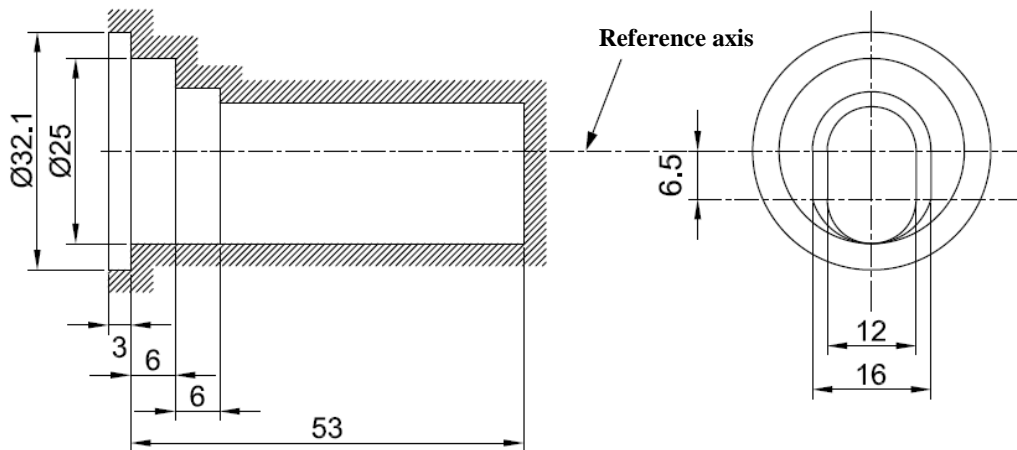

Figure 3
Maximum lamp outline ²



¹ The reference axis is perpendicular to the reference plane and crosses the intersection of the two parallel lines as indicated in figure 2.

² Glass bulb and supports shall not exceed the envelope, as indicated in figure 3. The envelope is concentric with the reference axis.

CATEGORY D6S

Sheet D6S/3

<i>Dimensions</i>		<i>Production light sources</i>	<i>Standard light sources</i>	
Position of the electrodes		Sheet D6S/4		
Position and form of the arc		Sheet D6S/5		
α_1, α_2 / ¹		55° min.	55° min.	
D6S: Cap P32d-1 in accordance with IEC Publication 60061 (sheet 7004-111-[4])				
ELECTRICAL AND PHOTOMETRIC CHARACTERISTICS				
Rated voltage of the ballast	V	12 ²	12	
Rated wattage	W	25	25	
Test voltage	V	13.2	13.2	
Objective lamp voltage	V	42 ± 9	42 ± 4	
Objective lamp wattage	W	25 ± 3	25 ± 0.5	
Objective Luminous flux	lm	2000 ± 300	2000 ± 100	
Chromaticity coordinates	Objective	x = 0.375	y = 0.375	
	Tolerance area ³	Boundaries	x = 0.345 x = 0.405	y = 0.150 + 0.640 x y = 0.050 + 0.750 x
		Intersection points	x = 0.345	y = 0.371
			x = 0.405	y = 0.409
			x = 0.405	y = 0.354
x = 0.345	y = 0.309			
Hot-restrike switch-off time	s	10	10	

¹ The part of the bulb within the angles α_1 and α_2 shall be the light emitting part. This part shall be as homogeneous in form as possible and shall be optically distortion free. This applies to the whole bulb circumference within the angles α_1 and α_2 .

² Application voltages of ballasts may differ from 12 V.

³ See Annex 4.

CATEGORY D6S

Sheet D6S/4

Position of the electrodes

This test is used to determine whether the electrodes are correctly positioned relative to the reference axis and the reference plane.

Top view (schematic):

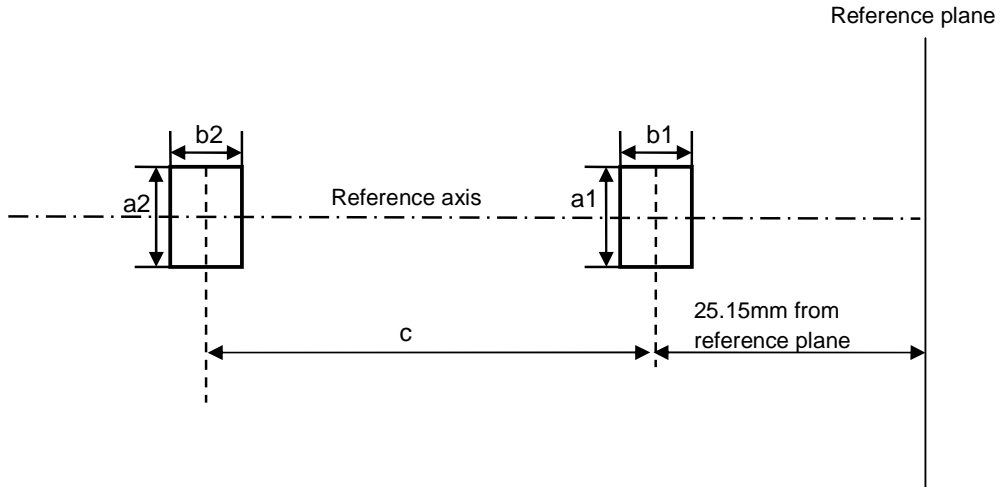

Side view (schematic):

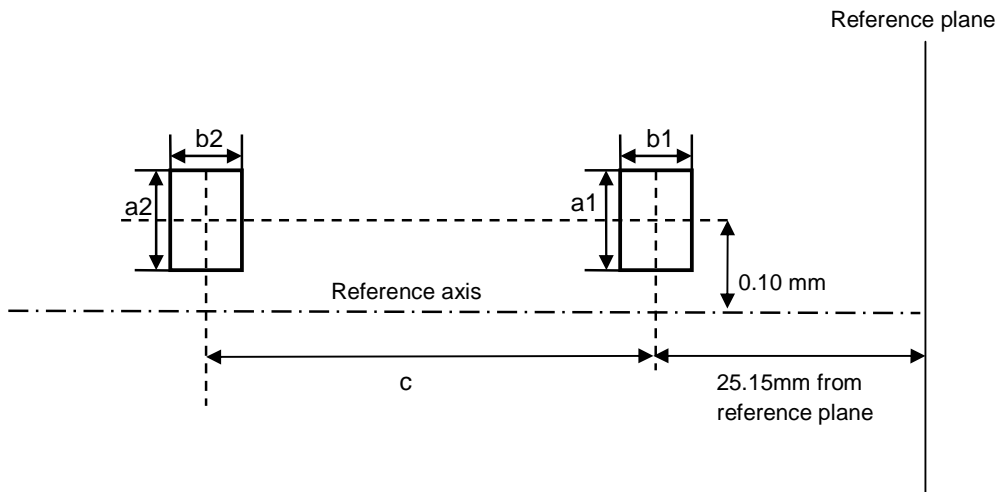

Measuring direction: light source side and top view

<i>Dimension in mm</i>	<i>Production light sources</i>	<i>Standard light sources</i>
a1	0.30	0.20
a2	0.50	0.25
b1	0.30	0.15
b2	0.60	0.30
c	3.90	3.90

The arc attachment point to the electrode nearest to the reference plane shall be positioned in the area defined by a1 and b1. The arc attachment point to the electrode furthest from the reference plane shall be positioned in the area defined by a2 and b2.

Position and form of the arc

This test is used to determine the form of the arc and its position relative to the reference axis and the reference plane by measuring its bending and diffusion in the cross section at a distance 27.1 mm from the reference plane.

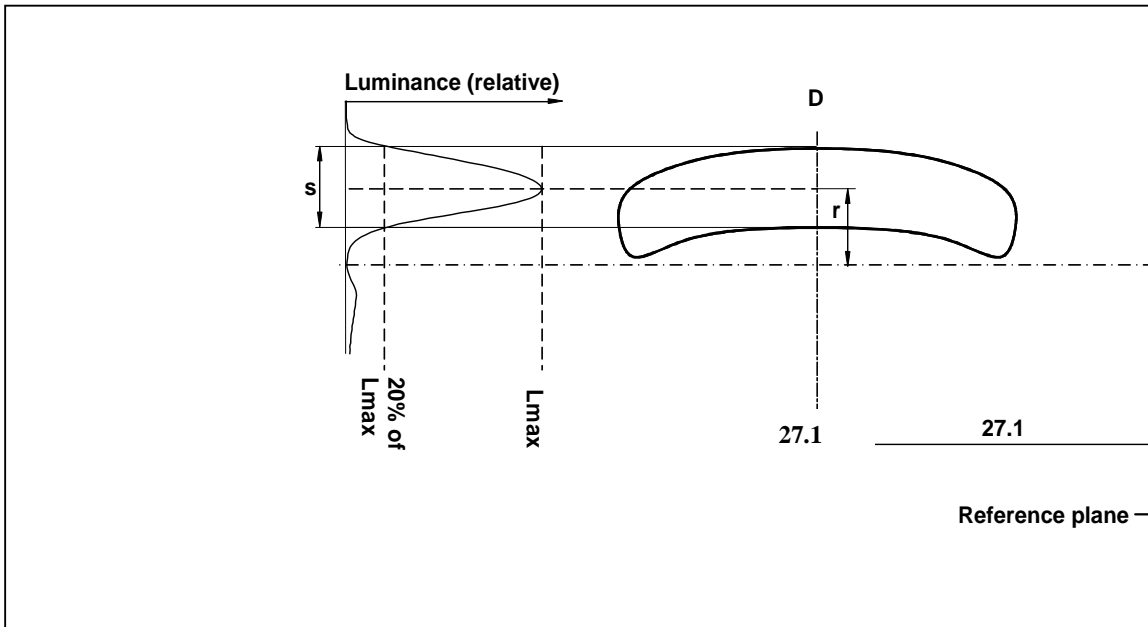

Relative luminance distribution in the central cross section D.

The form of the arc is for illustration purpose only.

Measuring direction: light source side view

When measuring the relative luminance distribution in the central cross section as indicated in the drawing above, the maximum value shall be located within the distance r from the reference axis. The point of 20 per cent of the maximum value shall be within s.

<i>Dimension in mm</i>	<i>Production light sources</i>	<i>Standard light sources</i>
r (arc bending)	0.50 +/-0.25	0.50 +/-0.15
s (arc diffusion)	0.70 +/-0.25	0.70 +/-0.15

”

Annex 2, item 5, amend to read:

- “5. Brand and type number of the ballast.....
(In case the ballast is not integrated with the light source.)”

Annex 4, paragraph 2, amend to read:

- “2. *Ballast*
In the case the ballast is not integrated with the light source, all tests and measurements shall be carried out with the ballast as per paragraph 2.2.2.4. of this Regulation. The power supply used for the starting and run-up tests shall be qualified to secure the quick rise of the high current pulse.”

Annex 4, paragraph 8, amend to read:

- “8. *Hot restrike test*
 The light source shall be started and be operated with the ballast (**possibly integrated**) at test voltage for a period of 15 minutes. Then the supply voltage to the ballast **or the light source with the ballast integrated** shall be switched off for a switch-off period as indicated on the relevant data sheet and be switched on again.”

Annex 4, paragraph 10, amend to read:

- “10. *Colour*
 The colour of the light source shall be measured in an integrating sphere using a measuring system which shows the CIE chromaticity co-ordinates of the received light with a resolution of ± 0.002 . The following figure shows the colour tolerance area for colour white and the restricted tolerance area for the gas-discharge light sources D1R, D1S, D2R, D2S, D3R, D3S, D4R, ~~and~~ D4S, **D5S and D6S.**”

II. Justification

1. This is a proposal introduces new categories of gas discharge light sources D5S and D6S according to the latest, high efficiency, mercury free technology, providing 2000 lm at 25W. The main target is middle class vehicles, today equipped with halogen headlamps. Application in these vehicles without additional installation requirements allows for a higher illumination on the road at lower power consumption. This is beneficial to both traffic safety and environmental protection.
2. D5S extends the existing range of D1S and D3S categories that have the starter integrated with the light source, where the ballast is a discrete component. In the case of D5S however, the ballast is integrated with the light source, too. A high voltage connection is thus avoided; only a 12V input is necessary. D5S is very compact, which results in less volume and build-in depth of the headlamp under the hood. The low volume may also be attractive to motorcycle headlamps.
3. D6S extends the existing range of D2S and D4S categories, where the starter and ballast are discrete components. Hence components can be replaced each when necessary. Proposals specifying cap/holder details are under consideration by International Electrotechnical Commission (IEC).