

## ELSA 5th meeting, January 22./23., 2009

## ELECTRICAL SAFETY PROVISIONS FOR VEHICLES IN USE

## 1. General

This module shall apply to the ~~drive electric power~~ train of ~~road vehicles equipped with one or more traction motor(s) operated by electric power electric vehicles, hybrid vehicles and fuel cell vehicles, and not permanently connected to the grid~~ and the high voltage components and systems which are galvanically connected to the high voltage bus of the electric power train.

## 2. Definitions

For the purpose of this regulation the following definitions apply:

## 2-1 Electric power train

the electrical circuit which ~~includes the traction motor(s), and may include the RESS, the energy conversion system, the electronic converters the traction motors, the associated wiring harness and connectors, and the coupling system for charging the RESS.~~

## 2-2 "RESS"

Rechargeable energy storage system that provides ~~the~~ electric energy for ~~electric~~ propulsion.

~~2-2 "Traction battery"~~

~~the electrical power storage units which are electrically connected, and its assembly, for the supply of energy of the power~~

## 2-3 Energy conversion system

system that generates and provides electric energy for ~~electric~~ propulsion.

## 2-4 Electronic converter

a device capable of controlling or converting electric power ~~for electric propulsion.~~

## 2-5 Coupling system for charging the RESS

the electrical circuit used for charging the RESS from an external electric power supply including the vehicle inlet.

## 2-6 External electric power supply

an AC or DC electric power supply outside of the vehicle.

## 2-7 Passenger compartment

the space for occupant accommodation, bounded by the roof, floor, side walls, doors, window glass, front bulkhead and rear bulkhead, or rear gate, as well as by the barriers and enclosures provided for protecting the power train from direct contact with live parts.

## OICA proposal / JAMA proposal

## 2-8 Luggage compartment

the space in the vehicle for luggage accommodation, bounded by the roof, hood, floor, side walls, as well as by the barrier and enclosure provided for protecting the power train from direct contact with live parts, being separated from the passenger compartment by the front bulkhead or the rear bulk head.

## 2-9 Direct contact

the contact of persons with live parts.

## 2-10 Live parts

conductive part(s) intended to be electrically energized in normal use.

## 2-11 Indirect contact

the contact of persons with exposed conductive parts.

~~2-12 “Protection degree IPXXB” and “Protection degree IPXXD” refer to those defined in ISO 20653 (2006??), Road vehicles – Degrees of protection (IP Code) – Protection of electrical equipment against foreign objects, water and access~~

## Protection degree

Protection provided by a barrier/enclosure related to the contact with live parts by a test probe, such as a test finger (IPXXB) or a test wire (IPXXD), as defined in Attached Sheet 3.

## 2-13 Exposed conductive part

conductive part which can be touched under the provisions of the applicable protection degree IPXXB (see 2.7), and which ~~is not normally alive, but which may~~ becomes electrically energized under ~~any~~ isolation-failure conditions.

~~2-?? “Non-exposed conductive part”~~

~~Conductive part which cannot be touched under the provisions of the applicable protection degree (see 2.7)]~~

## 2-14 Electrical circuit

an assembly of connected live parts ~~through~~ which ~~are an electric current~~ is ~~designed designated~~ to be electrically energized ~~pass~~ in normal operation. ~~conditions.~~

## 2-15 Working voltage

the highest value of an electrical circuit voltage (**r.m.s.**), specified by the manufacturer, which may occur between any conductive parts in open circuit conditions or under normal ~~operation~~ **operating** condition. **If the electrical circuit is divided by galvanic isolation, the working voltage is defined for each divided circuit, respectively.**

## 2-16 Electrical chassis

a set made of conductive parts electrically linked together, whose potential is taken as reference.

## OICA proposal / JAMA proposal

## 2-17 Solid insulator

insulating coating of wiring harnesses provided in order to cover and protect the live parts against direct contact from any direction of access; covers for insulating the live parts of connectors; and varnish or paint for the purpose of insulation.

## 2-18 Barrier

the part providing protection against direct contact to the live parts from any direction of access.

## 2-19 Enclosure

the part enclosing the internal units and providing protection against direct contact from any ~~usual~~ direction of access.

## 2-20 Service plug

the device for shutting off the electrical circuit when conducting checks and services of the ~~traction battery~~ RESS, fuel cell stack, etc.

## 2-21 On-board isolation resistance monitoring system

the device which monitors the isolation resistance between the high voltage buses and the electrical chassis.

## 2-22 High Voltage

classification of an electric component or circuit, if its maximum working voltage is  $> 60 \text{ V}$  and  $\leq 1500 \text{ V}$  d.c. or  $> 30 \text{ V}$  and  $\leq 1000 \text{ V}$  a.c. ~~respectively~~

## 2-23 High Voltage Bus

electrical circuit, including the ~~vehicle~~ coupling system for charging the RESS, that operates on high voltage, ~~that operates on high voltage 2-24 Active driving possible mode~~

## 2-24 Active driving possible mode

vehicle mode when application of pressure to the accelerator pedal (or activation of an equivalent control) will cause the ~~drive electric power~~ train to move the vehicle.

## 2-25 Open type traction battery

a liquid type battery requiring refilling with water and generating hydrogen gas released to the atmosphere.

## 2-26 Conductive connection

connection using contactors to an external power supply when the RESS is charged.

## OICA proposal / JAMA proposal

**3 Requirements for Protection against Electrical Shock**

## 3-1 General

These electrical safety requirements apply to high voltage buses ~~which are not galvanically connected under conditions where they are not connected~~ to external high voltage power supplies.

## 3-2 Protection against direct contact

The protection against direct contact with live parts shall comply with paragraphs 3-2-1 and 3-2-2. These protections (solid insulator, barrier, enclosure, etc.) ~~shall be reliably secured and sturdy, and they~~ shall not be able to be opened, disassembled or removed without the use of tools.

~~However, connectors of the high voltage bus may be separated without the use of tools, provided that they comply with the requirements of paragraphs 3-2-1 and 3-2-2 when separated. This requirement is fulfilled if other components must be removed with the use of tools in order to separate the connector.~~

Connectors (including vehicle inlet) are deemed to meet this requirement if:

- they comply with 3-2-1 and 3-2-2 when separated without the use of tools or
- they are located underneath the floor and are provided with a locking mechanism or
- they are provided with a locking mechanism and other components must be removed with the use of tools in order to separate the connector or
- the voltage of the live parts becomes equal or below DC 60V or equal or below AC 30V (r.m.s.) within 1 second after the connector is separated

## 3-2-1

For protection of live parts inside the passenger compartment or luggage compartment, the protection degree IPXXD shall be provided.

## 3-2-2

For protection of live parts in areas other than the passenger compartment or luggage compartment, the protection degree IPXXB ~~must~~ shall be satisfied.

## 3-2-3 Service plug

For the service plug which can be opened, disassembled or removed without tools, it is acceptable if protection degree IPXXB is satisfied under a condition where it is opened, disassembled or removed without tools.

**Protection degrees IPXXB and IPXXD are related respectively, to the contact of a jointed test finger and a test wire with hazardous parts (Attached Sheet 3).**

~~3-2-4 Vehicle inlet~~

~~However, this the provision requirements of §§ 3-2-1 and 3-2-2 shall not apply to the vehicle inlet where the voltage of the live parts becomes equal or below DC 60V or equal or below AC 30V (r.m.s.) immediately after the connection to the external power supply is released.]~~

## 3-2-4 Marking

The symbol shown in Figure 1 shall appear near ~~high voltage electric energy sources as the RESS. and fuel cell stacks.~~

**OICA proposal / JAMA proposal**

The same symbol shall be visible on enclosures and barriers, which, when removed expose live parts of high voltage circuits ~~and/or basic insulation.~~

~~[Accessibility and remove ability of barriers / enclosures should be considered for the necessity of the symbol.]~~

However, this provision shall not apply to any of the following cases

- where barriers or enclosures cannot be disassembled, opened or removed, unless other components are removed with the use of tools.
- where barriers or enclosures are located underneath the vehicle floor
- where double or more protections are provided by the barrier, enclosure or solid insulator.

The symbol background shall be yellow, the bordering and the arrow shall be black.

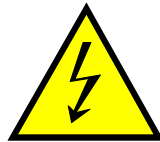

Figure 1 — Marking of high voltage equipment

The outer covering of cables and harness for high voltage buses circuits, not within enclosures or not underneath the vehicle floor shall be identified by orange color or a similar color.

This provision shall not apply to any connectors for high voltage buses.

~~NOTE 1 High voltage connectors may be identified by the harnesses to which the connector is attached.~~

### 3-3 Protection against indirect contact

#### 3-3-1 Potential Equalization

For protection against electrical shock which could arise from indirect contact, the exposed conductive parts, such as the conductive barrier and enclosure, shall be galvanically connected securely to the electrical chassis by connection with electrical wire or ground cable, or by welding, or by connection using bolts, etc. so that no dangerous potentials are produced.

**3-3-2** The resistance between all exposed conductive parts and the electrical chassis shall be lower than 0.1 ohm when there is current flow of at least 0.2 amperes.

~~The said resistance shall be regarded as lower than 0.1 ohm when it is clearly evident that the DC electrical connection has been established [adequately and securely by such means as] welding.~~

This requirement is satisfied if the galvanic connection has been established by welding.

**3-3-3** In the case of motor vehicles which are connected to the grounded external electric power supply through the conductive connection, a device to enable for the galvanical connection of the electrical chassis to the earth ground shall ~~must~~ be provided.

## OICA proposal / JAMA proposal

**Note:** The vehicle inlet The device should enable connection to the earth ground before exterior voltage is applied to the vehicle and retain the connection until after the exterior voltage is switched-off-removed from the vehicle.

Compliance to this requirement may be demonstrated either by using the connector specified by the car manufacturer, or by analysis.

### 3-3-2 3-4 ~~Insulation~~ Isolation Resistance

#### ~~3-3-2-1~~ 3-4-1 Electric power train consisting of separate DC- or AC-buses

If AC high voltage buses and DC high voltage buses are galvanically isolated from each other, ~~Electrical~~ isolation resistance between the high voltage bus and the electrical chassis shall be ~~> 100 ohms/volt~~ have a minimum value of **100** ohms/volt of the working voltage for DC buses, and ~~> 500 ohms/volt~~ a minimum value of **500** ohms/volt of the working voltage for AC buses.

The measurement shall be conducted according to Attached Sheet 1 “Isolation Resistance Measurement Method” or a method equivalent to it.

#### ~~3-3-2-2~~ 3-4-2 Electric power train consisting of combined DC- and AC-buses

If AC high voltage buses and DC high voltage buses are galvanically connected isolation resistance between the high voltage bus and the electrical chassis ~~when the vehicle is not connected to the external power supply~~ shall have a minimum value of **500** ohms/volt of the working voltage.

However, if all AC high voltage buses are protected by one of the 2 following measures, isolation resistance between the high voltage bus and the electrical chassis shall have a minimum value of **100** ohms/volt of the working voltage.

- Double or more layers of solid insulators, barriers or enclosures that meet the requirement in paragraph 3.2 independently, for example wiring harness
- Mechanically robust protections that have sufficient durability over vehicle service life such as motor housings, electronic converter cases or connectors.

The isolation resistance between the high voltage bus and the electrical chassis may be demonstrated by calculation, measurement or a combination of both.

The measurement shall be conducted according to Attached Sheet 1 “Isolation Resistance Measurement Method” or a method equivalent to it.

**3-4-3** If the minimum isolation resistance requirement cannot be maintained, then protection shall be achieved by any of the following:

- Double or more layers of solid insulators, barriers or enclosures that meet the requirement in paragraph 3.2 independently
- Onboard isolation resistance monitoring system together with a warning to the driver if the isolation resistance drops below the minimum required value. **The isolation resistance between the high voltage bus of the coupling system for charging the RESS, which is not energized besides during charging the RESS, and the electrical chassis need not to be monitored.** The function of the on-board isolation resistance monitoring system shall be confirmed as described in Attached Sheet 2.

## OICA proposal / JAMA proposal

**4. Requirements for ~~traction batteries~~ RESS**

## 4-1 Protection against excessive current

The RESS shall be equipped with a protective device (such as fuses or circuit breakers) if necessary in order to prevent overheating from excessive current. ~~However, this provision shall not apply to cases where there is no likelihood of dangerous effects resulting from excessive currents in the wires and the traction battery. This shall be demonstrated by testing or calculation.~~

## 4-2 Accumulation of Gas

Places for containing open type traction battery that may produce hydrogen gas shall be provided with a ventilation fan or a ventilation duct to prevent the accumulation of hydrogen gas. ~~No hydrogen gas shall enter the passenger compartment.~~

**5. Requirements for Functional Safety**

At least a momentary indication must be given to the driver either

- (a) when the vehicle is in "active driving possible mode" or,
- (b) when one further action is required to place the vehicle in "active driving possible mode".

However, this provision does not apply under conditions where an internal combustion engine provides directly or indirectly the vehicle's propulsion power.

When leaving the vehicle, the driver shall be informed by a **obvious** signal (e.g. optical or audible signal) if ~~the vehicle drive train~~ is still in the active driving possible mode.

If the on-board RESS can be externally charged by the user, vehicle movement by its own propulsion system shall be impossible as long as the connector of the external **electric** power supply is physically connected to the vehicle inlet.

This requirement shall be demonstrated by using the connector specified by the car manufacturer.

## OICA proposal / JAMA proposal

Attached Sheet 1

**ISOLATION RESISTANCE MEASUREMENT METHOD**

## 1. General

The isolation resistance for each high voltage bus of the vehicle shall be measured or shall be determined by calculation using measurement values from each part or component unit of a high voltage bus (hereinafter referred to as the “divided measurement”).

## 2. Measurement Method

The isolation resistance measurement shall be conducted by selecting an appropriate measurement method from among those listed in Paragraphs 2–1 through 2–3, depending on the electrical charge of the live parts or the isolation resistance, etc.

The range of the electrical circuit to be measured shall be clarified in advance, using electrical circuit diagrams, etc.

Moreover, modification necessary for measuring the isolation resistance may be carried out, such as removal of the cover in order to reach the live parts, drawing of measurement lines, change in software, etc.

In cases where the measured values are not stable due to the operation of the on-board isolation resistance monitoring system, etc., necessary modification for conducting the measurement may be carried out, such as stopping of the operation of the device concerned or removing it. Furthermore, when the device is removed, it must be proven, using drawings, etc., that it will not change the isolation resistance between the live parts and the electrical chassis.

Utmost care must be exercised as to short circuit, electric shock, etc., for this confirmation might require direct operations of the high-voltage circuit.

## 2–1 Measurement method using DC voltage from off-vehicle sources

## 2–1–1 Measurement instrument

An isolation resistance test instrument capable of applying a DC voltage higher than the **maximum** working voltage of the high voltage bus shall be used.

## 2–1–2 Measurement method

An insulator resistance test instrument shall be connected between the live parts and the electrical chassis. Then, the isolation resistance shall be measured by applying a DC voltage higher than the **maximum** working voltage of the high voltage bus **and-coupling-system-for-charging, respectively.**

**If the system has several voltage ranges (e.g. because of boost converter) in galvanically connected circuit and some of the components can not withstand the working voltage of the entire circuit, the isolation resistance between those components and the electrical chassis can be measured separately by applying their own working voltage with those component disconnected.**

**[However, in cases where there is likelihood that parts are damaged during the measurement, because no appropriate application voltage is obtained due to the characteristics of the isolation resistance test instrument, it shall be permissible to perform the measurement with the next lower voltage level of the test instrument.] or with those parts removed.**





## OICA proposal / JAMA proposal

If  $V_1$  is greater than or equal to  $V_2$ , insert a standard known resistance ( $R_0$ ) between the negative side of the high voltage bus and the electrical chassis. With  $R_0$  installed, measure the voltage ( $V_1'$ ) between the negative side of the high voltage bus and the electrical chassis (see Figure 2).

Calculate the electrical isolation ( $R_i$ ) according to the following formula:

$$R_i = R_0 * (V_b / V_1' - V_b / V_1) \quad \text{or} \quad R_i = R_0 * V_b * (1 / V_1' - 1 / V_1)$$

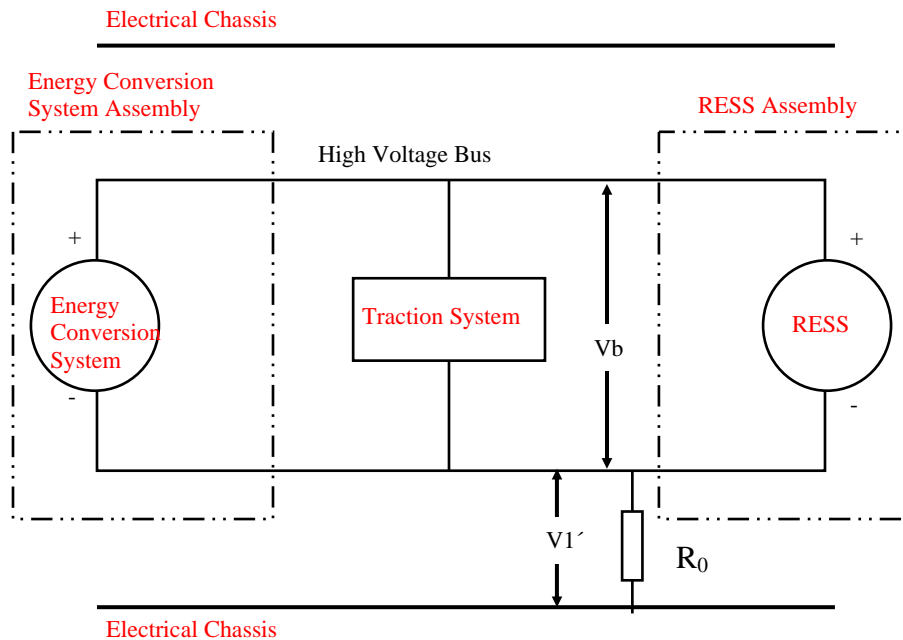

Figure 2: Measurement of  $V_1'$

If  $V_2$  is greater than  $V_1$ , insert a standard known resistance ( $R_0$ ) between the positive side of the high voltage bus and the electrical chassis. With  $R_0$  installed, measure the voltage ( $V_2'$ ) between the positive side of the high voltage bus and the electrical chassis. (See Figure 3). Calculate the electrical isolation ( $R_i$ ) according to the formula shown. Divide this electrical isolation value (in ohms) by the nominal operating voltage of the high voltage bus (in volts).

Calculate the electrical isolation ( $R_i$ ) according to the following formula:

$$R_i = R_0 * (V_b / V_2' - V_b / V_2) \quad \text{or} \quad R_i = R_0 * V_b * (1 / V_2' - 1 / V_2)$$

## OICA proposal / JAMA proposal

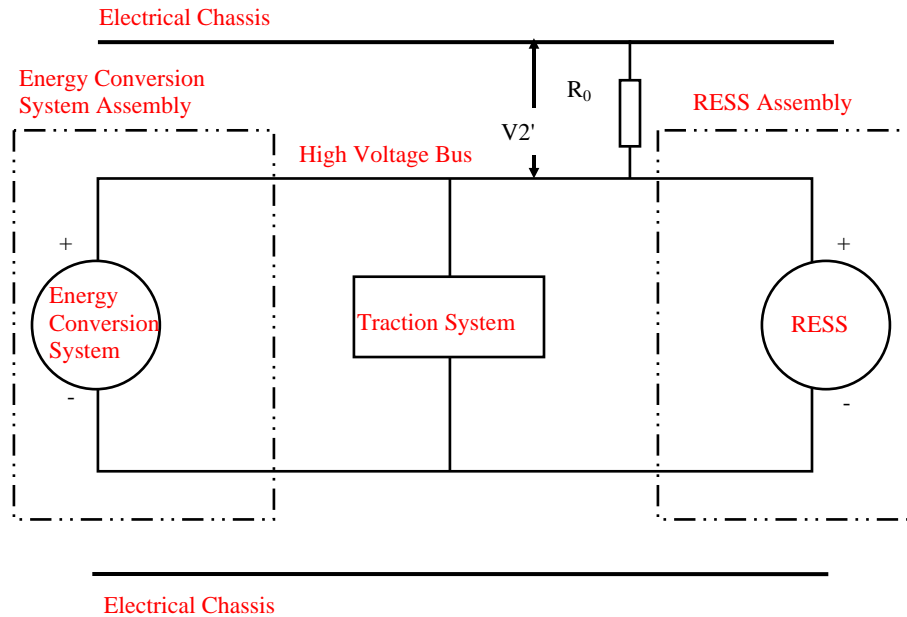
Figure 3: Measurement of  $V_2'$ 

## 2-2-3-5 Fifth step

The electrical isolation value  $R_i$  (in ohms) divided by the **maximum operating working** voltage of the high voltage bus (in volts) ~~shall be equal to or greater than 100  $\Omega/V$  for high voltage d.c. electric circuits or 500  $\Omega/V$  for high voltage a.c. electric circuits.~~ results in the isolation resistance (in ohms/volt).

**[NOTE 1: The standard known resistance  $R_0$  (in ohms) should be approximately 500 times the value of the minimum required isolation resistance (in ohms/V) multiplied by the nominal operating working voltage of the vehicle plus minus 20% (in volts).  $R_0$  is not required to be precisely this value since the equations are valid for any  $R_0$ ; however, a  $R_0$  value in this range should provide good resolution for the voltage measurements.]**

## OICA proposal / JAMA proposal

Attached Sheet 2 (for information)

### ~~FUNCTION CONFIRMATION METHOD OF POWER SUPPLY SHUT-OFF AT TIME OF ELECTRIC LEAKAGE~~

~~The following shall prescribe the function confirmation method and requirements of power supply shut-off at time of electric leakage.~~

#### ~~1. Confirmation method for functions of power supply shut-off at time of electric leakage~~

~~Paragraph 1-1 shows an example of the confirmation method in which leakage of electric current is caused by the resistor. Paragraph 1-2 gives an example of the confirmation method in which pseudo-signal is added.~~

~~This confirmation requires the operation of the high-voltage circuit directly. Therefore, utmost care must be exercised as to short-circuit, electrical shock, etc.~~

##### ~~1-1 Example of confirmation method in which leakage of electric current is caused by resistor~~

~~An appropriate resistor shall be inserted between the terminal for which the leaking electric current is monitored and the electrical chassis. At this time, the relationship between the electric current flowing in the resistor and the time elapsed until the shutting-off, shall be measured. The measurement shall be conducted with various electric currents by changing the resistance of the resistor connected.~~

##### ~~1-2 Example of confirmation method using a pseudo-signal~~

~~In cases where the relationship between the input value and output voltage of the sensor is clear through the submitted data of characteristics of the sensor being used, etc., the relationship between the pseudo-voltage being applied and the time elapsed until the shutting-off shall be measured when a pseudo-voltage corresponding to the output voltage equivalent to the shutting-off limitation is applied instead of the output of the sensor concerned.~~

#### ~~2. Requirements of power supply shut-off at time of electric leakage~~

~~The shut-off requirements shall be prescribed according to the leaking electric current and continuation time. Shutting-off shall take place below 200 mA when the continuation time is 10 msec or less; below the electric current determined from the following formula according to the continuation time when the continuation time is between 10 msec and 2 seconds; and below 26 mA when the continuation time is 2 seconds or more.~~

$$I=10-0.38507 \log_{10} t+2.6861$$

~~where:~~

~~I: Leaking electric current (mA)~~

~~t: Continuation time (msec)~~

~~Leaking electric current I (mA)~~

## OICA proposal / JAMA proposal

Attached Sheet 2

**2-3.1—Measurement method by an on-board insulation resistance monitoring system****2-3-1—Measurement instrument**

The on-board insulation resistance monitoring system shall be capable of monitoring the insulation resistance between the live parts and the electrical chassis and of giving a warning before it drops to 100  $\Omega/V$  for high voltage d.c. electric circuits or 500  $\Omega/V$  for high voltage a.c. electric circuits. Its function shall be confirmed by the method indicated in Paragraphs 2-3-1-1 through 2-3-1-2 or a method equivalent to it.

**2-3-1-1 Example of confirmation method in which a resistor is inserted in parallel in the high-voltage circuit**

Warning of the driver shall be given when a resistor is inserted which makes the combined insulation resistance between the terminal being monitored and the electrical chassis 100  $\Omega/V$  for high voltage d.c. electric circuits or 500  $\Omega/V$  for high voltage a.c. electric circuits.

**2-3-1-2 Example of confirmation method in which a pseudo signal is inputted**

In cases where the relationship between the input value and output voltage of the sensor is clear warning shall be given when a pseudo voltage corresponding to the output voltage equivalent to 100  $\Omega/V$  for high voltage d.c. electric circuits or 500  $\Omega/V$  for high voltage a.c. electric circuits is applied instead of the output of the sensor concerned.

**2-3-2—Measurement method**

Confirm that no warning is given under a condition that the on-board insulation resistance monitoring system is operating. In this case, confirmation as to whether or not the insulation resistance drop monitor is operating may be performed by means of the initial check function of the warning lamp when the motor vehicle is started.

If no warning is given, the insulation resistance shall be regarded as more than 100  $\Omega/V$  for high voltage d.c. electric circuits or 500  $\Omega/V$  for high voltage a.c. electric circuits.]

**Confirmation Method for Functions of On-board Isolation Resistance Monitoring System**

The function of the on-board isolation resistance monitoring system shall be confirmed by the following method or a method equivalent to it

When a resistor is inserted which causes the isolation resistance between the terminal being monitored and the electrical chassis to drop **below to** the minimum required isolation resistance value, the warning shall be activated.

**However, if the isolation resistance between the terminal being monitored and the electrical chassis cannot be set to the minimum required isolation resistance value due to the resistance of a resistor inserted, the setting shall be made to the smallest possible resultant resistance of the minimum required isolation resistance value or greater.**

## OICA proposal / JAMA proposal

Attached Sheet 3

**PROTECTION DEGREES**

1 — IPXXB

Jointed test finger diameter 12; 80 length      Dimensions in millimetres

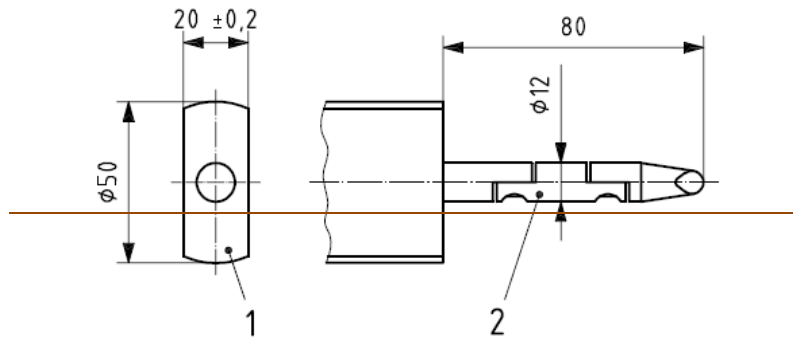
**Key**

- 1 stop face (diameter 50 × 20) (insulating material)
- 2 jointed test finger (metal)

The jointed test finger may penetrate over its full length of 80 mm but shall not contact be sufficiently distant from the hazardous parts, even when its joints are bent at any optional angle (up to 90° from its axis) and are brought into any possible position. The stop face (Ø50 mm × 20 mm) shall not pass through the opening.  
 The test force shall be 10 N ± 10 %.

## OICA proposal / JAMA proposal

## 2 — IPXXD

Test wire diameter 1,0; 100 long

Dimensions in millimetres

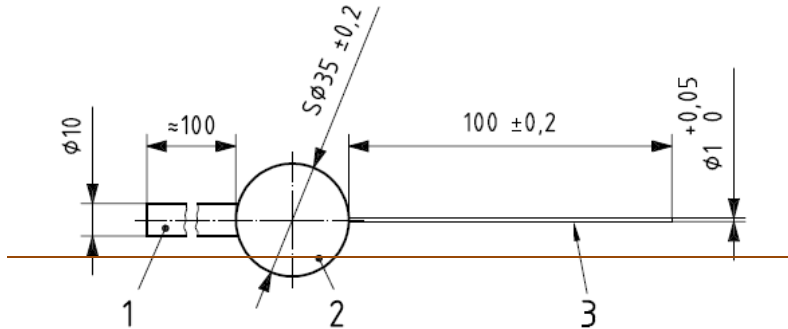

## Key

- 1 handle (insulating material)
- 2 stop face (insulating material)
- 3 sphere
- 4 rigid test wire (metal) (edges free from burrs)

The rigid test wire (diameter 1,0 mm, 100 mm long) may penetrate over its full length of 100 mm, but shall be sufficiently distant from hazardous parts in any possible angular position. The stop face (sphere  $\varnothing 35$  mm) shall not pass through the opening. The test force shall be  $1\text{ N} \pm 10\%$ .

## PROTECTION AGAINST DIRECT CONTACTS OF PARTS UNDER VOLTAGE

### 1. General

This test method shall apply to the electrical power train whose working voltage does not exceeding 1,000 V AC and 1,500 V DC.

### 2. Access probes

Access probes to verify the protection of persons against access to live parts are given in table 1.

### 3. Test conditions

The access probe is pushed against any openings of the enclosure with the force specified in table 1. If it partly or fully penetrates, it is placed in every possible position, but in no case shall the stop face fully penetrate through the opening.

Internal barriers are considered part of the enclosure.

A low-voltage supply (of not less than 40 V and not more than 50 V) in series with a suitable lamp should be connected, if necessary, between the probe and live parts inside the barrier or enclosure. Live parts covered only with varnish or paint which is not intended for solid insulator, or protected by oxidation or by a similar process, are covered by a metal foil electrically connected to those parts which are normally live in operation.

The signal-circuit method should also be applied to the moving live parts of high voltage equipment.

OICA proposal / JAMA proposal

Internal moving parts may be operated slowly, where this is possible.

4. Acceptance conditions

The access probe shall not touch live parts.

If this requirement is verified by a signal circuit between the probe and live parts, the lamp shall not light.

In the case of the test for IPXXB, the jointed test finger may penetrate to its 80 mm length, but the stop face (diameter 50 mm x 20 mm) shall not pass through the opening. Starting from the straight position, both joints of the test finger shall be successively bent through an angle of up to 90 degree with respect to the axis of the adjoining section of the finger and shall be placed in every possible position.

In case of the tests for IPXXD, the access probe may penetrate to its full length, but the stop face shall not fully penetrate through the opening

Table 1 - Access probes for the tests for protection of persons against access to hazardous parts

| First numeral | Addit. letter | Access probe  | Test force |
|---------------|---------------|---|------------|
| 2             | B             | <p style="text-align: center;"><b>Jointed test finger</b></p>  <p style="text-align: center;">See Fig. 1 for full dimensions</p> | 10N+/-10%  |
| 4.5.6         | D             | <p style="text-align: center;">Test wire 1.0 mm diameter 100 mm long</p>    | 1N+/-10%   |



Figure 1 - Jointed test finger

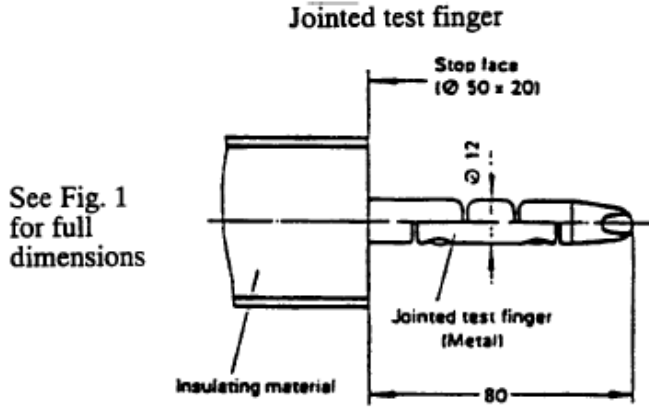
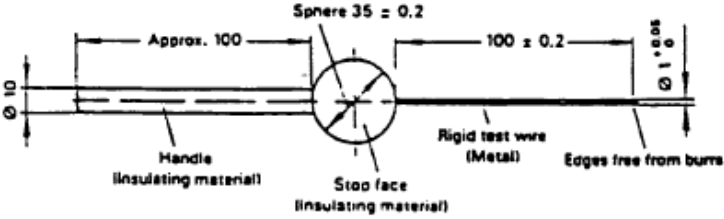
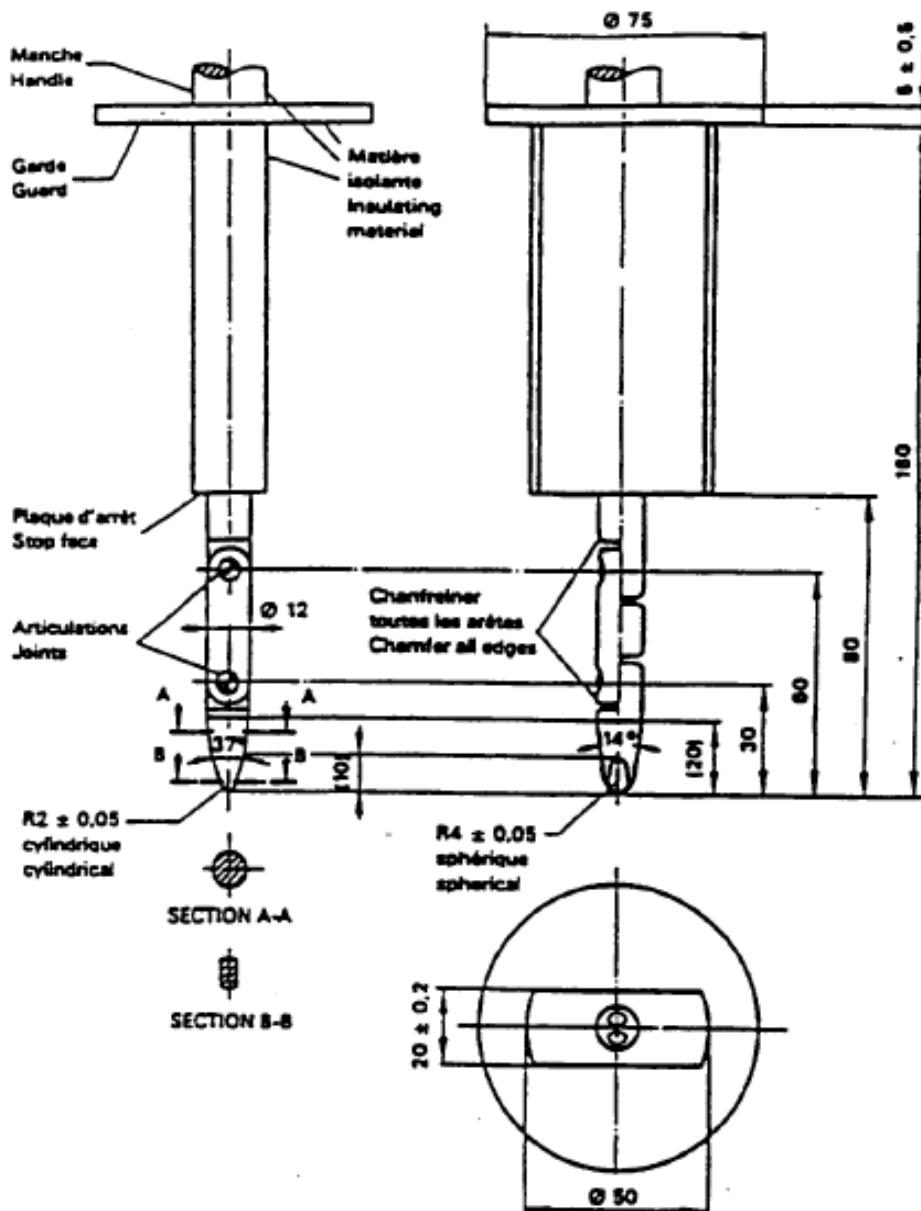

Material: metal, except where otherwise specified

Linear dimensions in millimeters

Tolerances on dimensions without specific tolerance:

on angles, 0/-10'

on linear dimensions:

up to 25 mm: 0/-0.05

over 25 mm: +/- 0.2

Both joints shall permit movement in the same plane and the same direction through an angle of 90° with a 0 to +10° tolerance.