



**Economic and Social  
Council**

Distr.  
GENERAL

ECE/TRANS/WP.11/220  
30 November 2009

Original: ENGLISH

---

**ECONOMIC COMMISSION FOR EUROPE**

**INLAND TRANSPORT COMMITTEE**

Working Party on the Transport of Perishable Foodstuffs

**REPORT OF THE WORKING PARTY ON THE TRANSPORT OF PERISHABLE  
FOODSTUFFS ON ITS SIXTY-FIFTH SESSION  
(27-30 October 2009)**

**CONTENTS**

	<i>Paragraphs</i>	<i>Page</i>
I. ATTENDANCE .....	1 - 2	4
II. INTRODUCTION .....	3	4
III. ADOPTION OF THE AGENDA (agenda item 1) .....	4	4
IV. ACTIVITIES OF ECE BODIES OF INTEREST TO THE WORKING PARTY (agenda item 2) .....	5 - 8	4
A. Inland Transport Committee.....	5 - 7	4
B. Working Party on Agricultural Quality Standards (WP.7).....	8	5
V. ACTIVITIES OF OTHER INTERNATIONAL ORGANIZATIONS DEALING WITH PROBLEMS OF INTEREST TO THE WORKING PARTY (agenda item 3) .....	9 - 15	5
A. International Institute of Refrigeration (IIR) .....	9	5
B. Transfrigoroute International.....	10	5
C. International Organization for Standardization (ISO) .....	11 - 12	5

**CONTENTS (continued)**

	<i>Paragraphs</i>	<i>Page</i>
D. Compatibility of ATP and European Union legislation.....	13	6
E. ATP Project for countries of Central Asia.....	14 – 15	6
<b>VI. STATUS AND IMPLEMENTATION OF THE AGREEMENT ON THE INTERNATIONAL CARRIAGE OF PERISHABLE FOODSTUFFS AND ON THE SPECIAL EQUIPMENT TO BE USED FOR SUCH CARRIAGE (agenda item 4).....</b>	<b>16 - 20</b>	<b>6</b>
A. Status of application of the Agreement .....	16	6
B. Status of amendments .....	17 - 18	7
C. Test stations officially designated by the competent authorities of countries Parties to ATP and whose test reports might be used for the issue of ATP certificates .....	19	7
D. Exchange of information among Contracting Parties under Article 6 of ATP .....	20	7
<b>VII. PROPOSALS OF AMENDMENTS TO THE ATP (agenda item 5) .....</b>	<b>21 - 37</b>	<b>8</b>
A. Pending issues .....	21 - 30	8
B. New proposals .....	31 - 37	10
<b>VIII. ATP HANDBOOK (agenda item 6) .....</b>	<b>38 - 45</b>	<b>12</b>
<b>IX. SCOPE OF ATP (agenda item 7).....</b>	<b>46 - 47</b>	<b>13</b>
<b>X. ENERGY LABELING, REFRIGERANTS AND BLOWING AGENTS (agenda item 8) .....</b>	<b>48</b>	<b>14</b>
<b>XI. PROGRAMME OF WORK AND BIENNIAL EVALUATION (agenda item 9).....</b>	<b>49 - 50</b>	<b>14</b>
<b>XII. RULES OF PROCEDURE (agenda item 10) .....</b>	<b>51- 53</b>	<b>15</b>
<b>XIII. INLAND TRANSPORT SECURITY (agenda item 11).....</b>	<b>54</b>	<b>15</b>
<b>XIV. ELECTION OF OFFICERS (agenda item 12) .....</b>	<b>55</b>	<b>16</b>
<b>XV. OTHER BUSINESS (agenda item 13).....</b>	<b>56 - 58</b>	<b>16</b>
Date of the next session.....	59	16
<b>XVI. ADOPTION OF THE REPORT (agenda item 14) .....</b>	<b>60</b>	<b>16</b>

Annexes

I.	Correction to the French text of Annex 1, Appendix 2 of the ATP.....	17
II.	Additions to the ATP Handbook.....	18
III.	Draft programme of work for 2010-2014 and biennial evaluation 2010-2011.....	22

## **I. ATTENDANCE**

1. The Working Party on the Transport of Perishable Foodstuffs (WP.11) held its sixty-fifth session from 27 to 30 October 2009 with Mr. T. Nobre (Portugal) as Chairman and Mr. G. Panozzo (Italy) as Vice-Chairman.

2. Representatives of the following countries took part in the session: Belgium, Czech Republic, Denmark, Finland, France, Germany, Ireland, Italy, Kazakhstan, Kyrgyzstan, Netherlands, Norway, Poland, Portugal, Russian Federation, Slovakia, Spain, Sweden, Tajikistan, Turkey, Ukraine, United Kingdom of Great Britain and Northern Ireland, United States of America and Uzbekistan. The intergovernmental organization International Institute of Refrigeration (IIR) and the non-governmental organizations Liaison Committee of the Body and Trailer Building Industry (CLCCR) and Transfrigoroute International (TI) also took part in the session. Representatives of SAFEGE, RINA Industry and IRD Engineering, the consortium responsible for the ATP Project in Central Asia, participated at the invitation of the secretariat.

## **II. INTRODUCTION**

3. The Director of the Transport Division, Eva Molnar, welcomed participants and in particular those from countries from Central Asia that were participating in WP.11's work for the first time and expressed her appreciation for the European Union's Transport Corridor Europe Caucasus Asia (TRACECA) programme which currently had a project to encourage the Central Asian countries to join the Agreement on the International Carriage of Perishable Foodstuffs and on the Special Equipment to be Used for such Carriage (ATP) and to set up ATP test stations. She urged the Working Party to seek compromise in adopting an ATP test for multi-compartment multi-temperature vehicles, which was long overdue. Finally, she welcomed the discussion by the Working Party on the possibility of holding a workshop in 2010 or 2011 on environmental aspects of refrigerated transport.

## **III. ADOPTION OF THE AGENDA (agenda item 1)**

4. The provisional agenda (ECE/TRANS/WP.11/219 and -/Add.1) was adopted.

## **IV. ACTIVITIES OF ECE BODIES OF INTEREST TO THE WORKING PARTY (agenda item 2)**

### **A. Inland Transport Committee**

Document: ECE/TRANS/206, ECE/TRANS/2009/6-9

5. The Working Party was informed that the ITC had noted with satisfaction that there were now forty-five Contracting Parties to the ATP and had welcomed the official adoption by the Working Party of the ATP Handbook, which would be a useful tool for clarifying provisions of the ATP, and also WP.11's consideration of the possible extension of the scope of the ATP to cover fresh fruit and vegetables.

6. As requested by the ITC, the Working Party's attention was drawn to documents ECE/TRANS/2009/6-9 on gender issues in transport.

7. With regard to the ITC's requests regarding global warming and transport and inland transport security, the Working Party decided to take up these issues under items 8 and 11 of its agenda. The Working Party also took note of the ITC's requests regarding the improved monitoring of legal instruments and transport and trade facilitation, including new areas of multimodal and intersectoral cooperation, electronic transport documents, intelligent transport systems (ITS) and innovative technological solutions for border crossings.

#### **B. Working Party on Agricultural Quality Standards (WP.7)**

8. The Working Party was informed about the recent work of WP.7 on the development of commercial agricultural quality standards for fresh fruit and vegetables and meat. The standards for meat can be found at the following link: [http://unece.org/trade/agr/standard/meat/meat\\_e.htm](http://unece.org/trade/agr/standard/meat/meat_e.htm) and those for fresh fruit and vegetables at: <http://unece.org/trade/agr/standard/fresh/FFV-Standards.htm>.

### **V. ACTIVITIES OF OTHER INTERNATIONAL ORGANIZATIONS DEALING WITH PROBLEMS OF INTEREST TO THE WORKING PARTY (agenda item 3)**

#### **A. International Institute of Refrigeration (IIR)**

Document: Informal document INF.10

9. The representative of IIR briefed the Working Party on the meeting of the IIR CERTE subcommission held in Castelo Branco, Portugal on 4 and 5 June 2009. The meeting had agreed on a number of recommendations relevant to the work of WP.11 (Informal document INF. 10) which would be discussed under the appropriate agenda items. The next meeting of the subcommission would be held in Cambridge, United Kingdom on 29 March 2010 in conjunction with an international Cold Chain Conference.

#### **B. Transfrigoroute International**

10. The representative of Transfrigoroute International informed the Working Party that his organization's annual general meeting had been held in Brussels on 17 and 18 September 2009. He informed WP.11 that next year's meeting would be held in Berlin at the end of October 2010 and invited WP.11 to consider holding its proposed workshop on environmental issues in conjunction with that meeting.

#### **C. International Organization for Standardization (ISO)**

11. The secretariat had formally invited a representative of ISO to participate in the Working Party's session but no official had been available to attend. The secretariat was requested to invite a representative of ISO to WP.11's sixty-sixth session.

12. The representative of Germany and chairwoman of TC113-WG13 informed WP.11 about a working group of the European Committee for Standardization (CEN) which was developing a series of standards on testing methodologies for insulated means of transport. Experts were invited to take part in that working group after contacting their national member body.

#### **D. Compatibility of ATP and European Union legislation**

13. The secretariat had formally invited a representative of the Directorate General for Energy and Transport to participate in the session and to inform the Working Party about the current work and future plans of the European Commission regarding regulatory or other activities concerning the transport of perishable foodstuffs. The invitation had been referred to Health and Consumer Protection Directorate General E – Safety of the Food Chain which had recognised its Directive 89/108/EEC (quick-frozen foodstuffs) and Regulation (EC) No. 37/2005 (devices for the monitoring of temperatures) as relevant issues but which had not been able to participate in the meeting. It was suggested that in future the secretariat contact DG Enterprise or the TRACECA Programme regarding participation in WP.11 sessions.

#### **E. ATP project for countries of Central Asia**

Document: Informal document INF.3

14. A presentation was made regarding the European Commission's project to establish ATP testing stations in the Central Asian countries funded by the TRACECA Programme (Informal document INF.3). ATP experts had been trained in Kazakhstan, Kyrgyzstan, Tajikistan and Uzbekistan. Kazakhstan and Uzbekistan were already Contracting Parties to ATP and Kyrgyzstan and Tajikistan were expected to accede shortly.

15. While the inclusion of Central Asian countries in the ATP was warmly welcomed by WP.11, a number of delegates expressed the regret that the European Commission had not consulted WP.11, IIR and Transfrigoroute International earlier for guidance, and commented that testing station software could have been made available to the project from a number of sources. One delegation expressed the opinion that an impact analysis of the project would have been desirable. Certain countries expressed their disappointment with the results of the project and were concerned that the companies engaged were not experts on the ATP.

### **VI. STATUS AND IMPLEMENTATION OF THE AGREEMENT ON THE INTERNATIONAL CARRIAGE OF PERISHABLE FOODSTUFFS AND ON THE SPECIAL EQUIPMENT TO BE USED FOR SUCH CARRIAGE (agenda item 4)**

#### **A. Status of application of the Agreement**

16. The Working Party was informed that there had been no new accessions to the ATP since the last session and that the number of Contracting Parties was 45 as follows: Albania, Andorra, Austria, Azerbaijan, Belarus, Belgium, Bosnia and Herzegovina, Bulgaria, Croatia, Czech Republic, Denmark, Estonia, Finland, France, Georgia, Germany, Greece, Hungary, Ireland, Italy, Kazakhstan, Latvia, Lithuania, Luxembourg, Moldova, Monaco, Montenegro,

Morocco, Netherlands, Norway, Poland, Portugal, Romania, Russian Federation, Serbia, Slovakia, Slovenia, Spain, Sweden, The former Yugoslav Republic of Macedonia, Tunisia, Ukraine, United Kingdom, United States of America, Uzbekistan.

## **B. Status of amendments**

Document: ECE/TRANS/WP.11/216 and Add.1, ECE/TRANS/WP.11/218/Add.1

17. The Working Party was informed that the Government of Germany had made a notification in accordance with Article 18 (2) (b) of the ATP stating that although it intended to accept the amendment proposals circulated on 2 April 2009 (ECE/TRANS/WP.11/218/Add.1), the conditions for such acceptance had not yet been fulfilled in its country. Consequently, the proposed amendments to the ATP would be deemed accepted only if, before the expiry of a further period of nine months after the initial notification period of six months (i.e. before 2 July 2010), the Government of Germany had not notified an objection to the proposed amendments. Corrigenda to ECE/TRANS/WP.11/218/Add.1 had a notification period until 24 November 2009.

18. Proposed amendments to the ATP adopted at the sixty-third session of WP.11 in 2007 (ECE/TRANS/WP.11/216 and Add.1) had been deemed accepted on 6 June 2009 and would enter into force on 6 December 2009. The secretariat stated that the new version of the ATP reflecting those amendments was available on the website in English, French and Russian.

## **C. Test stations officially designated by the competent authorities of countries Parties to ATP and whose test reports might be used for the issue of ATP certificates**

19. The current updated list of test stations appears at the following web link: <http://www.unece.org/trans/main/wp11/teststations.pdf>. Contracting Parties were invited to transmit corrections or new information to the secretariat.

## **D. Exchange of information among Contracting Parties under Article 6 of ATP**

Document: ECE/TRANS/WP.11/2009/5 and Informal document INF.2

20. The Working Party thanked those countries which had provided data for the questionnaire on the implementation of the ATP (ECE/TRANS/WP.11/2009/5) and stressed the importance of more countries responding to the questionnaire in 2010 if it was to be a meaningful exercise. The representative of the United Kingdom asked that an explanation be given in the 2010 version of the questionnaire of the terms used in the left hand column of table 2 (i.e. 2<sup>nd</sup> certificate inspection, 2<sup>nd</sup> certificate K value). France would send the secretariat corrections to its data. The Working Party appreciated the document listing those countries where ATP was also used as the basis for domestic transport of perishable foodstuffs (Informal document INF.2) and proposed that the question regarding domestic legislation be included in the questionnaire in future.

## **VII. PROPOSALS OF AMENDMENTS TO THE ATP (agenda item 5)**

### **A. Pending issues**

#### **1. Sea crossing**

Documents: ECE/TRANS/WP.11/2009/2

21. The WP.11 examined the proposal by Finland regarding the sea crossing and inland waterways (ECE/TRANS/WP.11/2009/2). Several countries expressed their opposition to the new provisions regarding containers and Germany argued that containers were already covered in the ATP under insulated equipment. Several countries expressed their support for changing the length of the sea crossing as proposed in the document. The WP.11 voted on the proposal and the results were as follows: 1 in favour (Finland), 11 against (Denmark, France, Germany, Ireland, Kazakhstan, Netherlands, Norway, Poland, Spain, Sweden and United States) and 9 abstentions (Belgium, Czech Republic, Italy, Portugal, Russian Federation, Slovakia, Ukraine, United Kingdom and Uzbekistan).<sup>1</sup> It was proposed that Finland should work by e-mail with the informal working group with the aim of submitting revised proposals to the sixty-sixth session. The different proposals should be submitted in different documents and proper justification of the proposals, including economic, should be provided.

#### **2. Multi-compartment multi-temperature vehicles**

Documents: ECE/TRANS/WP.11/2009/14

22. The Working Party considered the proposals made by France regarding tests for multi-compartment multi-temperature vehicles (ECE/TRANS/WP.11/2009/14).

23. The representative of Germany stated that he could not vote in favour of the proposal on the multi-temperature test because he had not received the TI and CLCCR documents in due time. The CLCCR, however, stated during the meeting that it was in favour of the French proposal.

24. The representative of Germany said that the proposal presented was not in line with the conclusions of the last two sessions of WP.11 and therefore was not acceptable.

25. The representative of TI stated that equipment dimensioned using the proposed method did not function correctly. He also explained that the body builders were against the proposal.

26. The representative of France stated that, aware of the absence of a position of TI on the proposal, he had consulted five refrigerated transport unit manufacturers. These five companies, out of the six existing in the world and which represented more than 95% of the multi-temperature market, had expressed their support for the proposal.

---

<sup>1</sup> The following 21 countries were eligible to vote at the session: Belgium, Czech Republic, Denmark, Finland, France, Germany, Ireland, Italy, Kazakhstan, Netherlands, Norway, Poland, Portugal, Russian Federation, Slovakia, Spain, Sweden, Ukraine, United Kingdom, United States and Uzbekistan. Countries that did not vote for or against a proposal are counted as abstentions.



27. Delegates regretted the late receipt of the English version of document ECE/TRANS/WP.11/2009/14 and the poor quality of the translation (e.g. the use of efficient capacity instead of useful capacity).

28. The WP.11 voted first on the title and definitions in the proposal. The voting was as follows: 14 in favour (Finland, France, Ireland, Italy, Kazakhstan, Netherlands, Poland, Portugal, Slovakia, Spain, Sweden, United Kingdom, United States and Uzbekistan), 1 against (Germany) and 6 abstentions (Belgium, Czech Republic, Denmark, Norway, Russian Federation and Ukraine). The vote on the test method for multi-temperature units was as follows: 15 in favour (Czech Republic, Finland, France, Ireland, Italy, Kazakhstan, Netherlands, Poland, Portugal, Slovakia, Spain, Sweden, United Kingdom, United States and Uzbekistan), 1 against (Germany) and 5 abstentions (Belgium, Denmark, Norway, Russian Federation and Ukraine). The final vote on the dimensioning method for ATP multi-temperature appliances was as follows: 15 in favour (Czech Republic, Finland, France, Ireland, Italy, Kazakhstan, Netherlands, Poland, Portugal, Slovakia, Spain, Sweden, United Kingdom, United States and Uzbekistan), 1 against (Germany) and 5 abstentions (Belgium, Denmark, Norway, Russian Federation and Ukraine). The proposal was therefore not accepted.

### **3. 12-year ATP tests**

Documents: ECE/TRANS/WP.11/2009/12, ECE/TRANS/WP.11/2009/15

29. The Working Party considered the amendments to Annex 1, Appendix 2, paragraph 29 proposed by France in ECE/TRANS/WP.11/2009/12 and by Spain in ECE/TRANS/WP.11/2009/15 concerning the renewal of ATP certificates for equipment at 12 years and older. Revised proposals were prepared and submitted during the session. The revised proposal by Spain was put to the vote and the results were as follows: 10 in favour (France, Ireland, Italy, Poland, Portugal, Russian Federation, Slovakia, Spain, United Kingdom and United States), 5 against (Finland, Germany, Kazakhstan, Ukraine and Uzbekistan) and 6 abstentions (Belgium, Czech Republic, Denmark, Netherlands, Norway and Sweden). The proposal was therefore not accepted. Asked to clarify the reason for their negative votes, Germany explained that it had voted against the proposal because it did not mention the K values of 0.40 and 0.70 for new vehicles as a point of reference. Finland considered that the proposal was an important step in the right direction, but instead of testing insulation capacity, the option of declassifying 12-year old heavily insulated (IR) equipment to normally insulated (IN) should be possible on the basis of a normal re-approval test. Finland also mentioned that distances to test stations might be long and in some countries there were no test stations at all and questioned whether the proposed text would apply to all equipment or only equipment manufactured after the entry into force of the proposal. Kazakhstan, Ukraine and Uzbekistan stated that it would be difficult to implement the proposed provisions in their countries without an adequate transition period. Others felt that the proposal could have made an important contribution to reducing CO<sub>2</sub> and stated that the K values of 0.40 and 0.70 applied to all vehicles and not just new vehicles. In light of the rejection of the revised Spanish proposal, the revised proposal by France was not put to the vote.

#### **4. 6- and 9-year ATP tests**

Document: ECE/TRANS/WP.11/2009/13

30. The Working Party considered the proposal by France regarding 6- and 9-year ATP tests for non-autonomous mechanically refrigerated equipment (ECE/TRANS/WP.11/2009/13). It was agreed to amend the proposal by reducing the minimum period when the engine is maintained at idle speed from two hours to one and a half hours and by replacing "a tolerance of about 100 revolutions" in the English version by "a tolerance of plus or minus 100 revolutions". The revised proposal was put to the vote and the results were as follows: 12 in favour (Finland, France, Germany, Ireland, Norway, Poland, Portugal, Russian Federation, Spain, Sweden, Ukraine and United Kingdom), 1 against (Netherlands) and 8 abstentions (Belgium, Czech Republic, Denmark, Italy, Kazakhstan, Slovakia, United States and Uzbekistan). The proposal was therefore not accepted. In response to a question from France, the Netherlands justified its objection to the proposal by the need for conducting an impact analysis in its country. However, it stated that it was open to discussion. France stated that it would work on the proposal and submit a new draft to the sixty-sixth session.

#### **B. New proposals**

##### **1. Annex 1, Appendix 1, paragraph 2 (a)**

Document: ECE/TRANS/WP.11/2009/11

31. The Working Party examined the proposal made by France to introduce a type-examination certificate in Annex 1, Appendix 1, paragraph 2 (a) (ECE/TRANS/WP.11/2009/11). A few countries argued that there was no data protection problem with the present system and that adding a new document could lead to duplication. However, since there was no objection in principle to a type-examination certificate, it was agreed that France would complete its proposal including the preparation of the proposed model of the certificate in cooperation with other interested countries in an informal working group and that a new proposal would be presented to the sixty-sixth session.

##### **2. Annex 1, Appendix 1, paragraph 2 (c) (ii)**

Document: ECE/TRANS/WP.11/2009/17

32. The Working Party considered the proposal made by Portugal to amend Annex 1, Appendix 2, paragraph 2 (c) (ii) in order to clarify the text with regard to eutectic plates (ECE/TRANS/WP.11/2009/17). It was pointed out that the proposal should cover eutectic tubes as well as eutectic plates. Several countries felt that more justification for the proposal was required. The voting was as follows: 3 in favour (Italy, Poland and Portugal), 2 against (Germany and Netherlands) and 16 abstentions (Belgium, Czech Republic, Denmark, Finland, France, Ireland, Kazakhstan, Norway, Russian Federation, Slovakia, Spain, Sweden, Ukraine, United Kingdom, United States and Uzbekistan). The proposal was therefore not accepted.

**3. Annex 1, Appendix 2, paragraph 29 (c)**

Document: ECE/TRANS/WP.11/2009/15

33. The proposal by Spain was considered under pending issues (see paragraph 29).

**4. Annex 1, Appendix 2, paragraph 49**

Document: ECE/TRANS/WP.11/2009/7

34. The Working Party considered the amendment to paragraph 49 proposed by Sweden in ECE/TRANS/WP.11/2009/7 concerning the certificate of maintenance of cooling appliances. Sweden argued that such a certificate was necessary to avoid the significant number of vehicles which failed the ATP test at 6 and 9 years. It was questioned whether it was correct to refer to the document as a "certificate" and the proposal was put to the vote as a "Service report of maintenance". The voting was as follows: 3 in favour (Finland, Spain and Sweden), 4 against (Denmark, Germany, Netherlands and Uzbekistan) and 14 abstentions (Belgium, Czech Republic, France, Ireland, Italy, Kazakhstan, Norway, Poland, Portugal, Russian Federation, Slovakia, Ukraine, United Kingdom and United States). The proposal was therefore not accepted.

**5. Annex 1, Appendix 2, paragraph 56**

Document: ECE/TRANS/WP.11/2009/10

35. The Working Party adopted the amendment proposed by France to correct an error in the test procedure defined in the French text only of paragraph 56 (ECE/TRANS/WP.11/2009/10). The voting was as follows: 16 in favour (Belgium, Denmark, Finland, France, Ireland, Italy, Poland, Portugal, Russian Federation, Slovakia, Spain, Sweden, Ukraine, United Kingdom, United States and Uzbekistan), none against and 5 abstentions (Czech Republic, Germany, Kazakhstan, Netherlands and Norway). It was agreed that the proposed correction which appears in Annex I to the present report would be transmitted to the Treaty Section for notification to ATP Contracting Parties under the accelerated procedure for corrections.

**6. Annex 1, Appendix 3**

Document: ECE/TRANS/WP.11/2009/18

36. The Working Party examined the proposal made by the Netherlands to include a transitional provision for the new model certificate of compliance (ECE/TRANS/WP.11/2009/18). Since the date of entry into force of the new revised annex 1 including the new certificate was not yet sure, the Working Party agreed to come back to the proposal but agreed to make it quite clear in its report that existing certificates would remain valid until their normal expiry date.

## **7. Annex 2, Appendix 1**

Document: ECE/TRANS/WP.11/2009/20

37. The Working Party considered the proposal made by the Russian Federation regarding devices for air temperature measurement and recording inside transport equipment during carriage of quick-frozen perishable foodstuffs intended for human consumption (ECE/TRANS/WP.11/2009/20). It was agreed that it was a useful document for non-EU countries. During the discussion there was debate about the need for the ATP to correspond to the standards mentioned in European legislation. In light of the lack of unanimity on this subject, it was proposed that the Russian Federation submit a corrected proposal for discussion at the sixty-sixth session of WP.11, taking into account that not all ATP Contracting Parties are members of the EU.

## **VIII. ATP HANDBOOK (agenda item 6)**

Documents: ECE/TRANS/WP.11/2009/4, ECE/TRANS/WP.11/2009/8, ECE/TRANS/WP.11/2009/9, ECE/TRANS/WP.11/2009/16, ECE/TRANS/WP.11/2009/17, ECE/TRANS/WP.11/2009/18, ECE/TRANS/WP.11/2009/19 and Informal document INF.6

38. As requested by the Working Party, the secretariat had prepared a discussion document proposing how the ATP Handbook should be used and procedures for updating it (ECE/TRANS/WP.11/2009/4). It was proposed that a number of the basic recommendations identified could be added to the draft rules of procedure of the Working Party (ECE/TRANS/WP.11/2009/6), i.e. making a reference to the report symbol and paragraph number after each comment, introducing examples of best practice in a separate section of the ATP Handbook, and requiring more than three negative votes to reject a proposal. Since there would probably be new additions to the ATP Handbook every year, it was decided that it should be updated on the internet and that for the time being a printed version was not necessary.

39. In response to a request by the Working Party at its sixty-fourth session, Slovakia had submitted a revised proposal regarding the ATP checklist, adding an introductory text and proposing where in the Handbook it could be included (ECE/TRANS/WP.11/2009/16). The Working Party proposed a number of modifications to the graphic: replacing "procedure" by "guidelines" in the title, adding a note that the manufacturer's plate is optional on the body, and ensuring that the French version was the same as the English including the addition of the serial number in the manufacturer's plate. The voting on the proposal was 14 in favour (Denmark, Ireland, Italy, Kazakhstan, Norway, Poland, Portugal, Russian Federation, Slovakia, Spain, Sweden, United Kingdom, United States and Uzbekistan), none against and 7 abstentions (Belgium, Czech Republic, Finland, France, Germany, Netherlands and Ukraine). The proposal was therefore adopted (see annex II to the present report).

40. The WP.11 discussed the proposal by the Russian Federation regarding the placement of temperature measuring equipment for K value testing of tanks with one, three and more compartments (ECE/TRANS/WP.11/2009/19). The voting was as follows: 16 in favour (Czech Republic, Denmark, Finland, Germany, Ireland, Italy, Kazakhstan, Netherlands, Norway, Poland, Portugal, Russian Federation, Slovakia, Spain, Sweden and United Kingdom), none

against and 5 abstentions (Belgium, France, Ukraine, United States and Uzbekistan). It was therefore decided to add the proposal to the ATP Handbook (see annex II to the present report).

41. The WP.11 discussed the proposal by the Russian Federation regarding the placement of temperature measuring equipment for K value testing of tanks with two compartments (Informal document INF.6). The Russian Federation agreed to submit a revised proposal as an official document to the sixty-sixth session highlighting the modifications and additions to be made to Annex 1, Appendix 2 as well as new comments to the ATP Handbook.

42. The Working Party did not consider the proposal by Portugal to introduce a comment in the ATP Handbook after Annex 1, Appendix 1, paragraph 2 (c) (ii) regarding the checking of equipment with eutectic plates (ECE/TRANS/WP.11/2009/17) since the corresponding amendment to the ATP had not been accepted.

43. The Working Party discussed the proposal by Sweden to introduce in the ATP Handbook a comment aimed at clarifying the situation with regard to the treatment of kit bodies (ECE/TRANS/WP.11/2009/9). Several countries found the proposal very useful but others argued that the point of the ATP Handbook was to clarify existing text in the ATP and at present there was no mention in the ATP of kit bodies. The voting was 6 in favour (Germany, Ireland, Italy, Sweden, United Kingdom and United States), 4 against (France, Netherlands, Spain and Uzbekistan) and 11 abstentions (Belgium, Czech Republic, Denmark, Finland, Kazakhstan, Norway, Poland, Portugal, Russian Federation, Slovakia and Ukraine). The proposal was therefore not accepted.

44. The proposal by Sweden to add a comment relating to a certificate of maintenance of cooling appliances (ECE/TRANS/WP.11/2009/8) was not discussed since the corresponding amendment in the ATP had not been accepted. However, the Netherlands proposed an alternative comment to paragraph 49 (b). The voting was 16 in favour (Belgium, Finland, Ireland, Italy, Kazakhstan, Netherlands, Norway, Poland, Portugal, Russian Federation, Slovakia, Spain, Sweden, United Kingdom, United States and Uzbekistan), none against and 5 abstentions (Czech Republic, Denmark, France, Germany and Ukraine). The comment was therefore accepted (see Annex II to the present report).

45. The proposal made by the Netherlands to include a comment in the ATP Handbook regarding the validity of the new model certificate of compliance (ECE/TRANS/WP.11/2009/18) was not discussed in the light of the discussion on a similar proposed amendment to the ATP (see paragraph 36).

## **IX. SCOPE OF ATP (agenda item 7)**

Documents: Informal document INF. 5

46. The Russian Federation informed the Working Party that it had not been able to submit a proposal on extending the scope of ATP to fruit and vegetables as requested because it had not received sufficient responses to its questionnaire which had been circulated to all ATP Contracting Parties in May 2009. Replies had only been received from Finland, Italy, Sweden and United Kingdom. Several countries commented that it was difficult to assign temperatures for all fruit and vegetables in the questionnaire and it was recommended that the Russian

Federation simplify the questionnaire by requesting data for a smaller number of fruit and vegetables and asking for temperature ranges rather than specific temperatures. Denmark, Sweden and the United Kingdom reiterated their opposition to the possible extension of the ATP to fresh fruit and vegetables. Italy pointed out that the first line of the ATP read "DESIROUS of improving the conditions of preservation of the quality of perishable foodstuffs...". The Russian Federation was invited to continue its work on developing a proposal for the sixty-sixth session.

47. The WP.11 took note of Informal document INF.5 submitted by the secretariat which reproduced passages of old documents dealing with the length of the sea crossing and with the definition of perishable foodstuffs.

#### **X. ENERGY LABELING, REFRIGERANTS AND BLOWING AGENTS** (agenda item 8)

Documents: Informal document INF. 11

48. The Working Party took note of Informal document INF.11 submitted by the secretariat on the case for an environmental workshop to be organized by WP.11 in 2010 or 2011. The representative of Transfrigoroute International offered to host the workshop at the end of October 2010 in Berlin in conjunction with Transfrigoroute International's annual meeting. It was also suggested that the workshop could be held in conjunction with the International Congress on the Cold to be held in Prague from 21-26 August 2011. A third possibility would be to hold the workshop during WP.11's sixty-seventh session in 2011. A few delegations felt that 2010 was not appropriate since other similar events were already scheduled to take place that year. Germany argued that the reason for and aim of such a workshop should be clearly defined before taking a decision on when and whether it should be held. Voting showed four countries in favour of holding an environmental workshop (France, Italy, Portugal and Spain), none against and 17 abstentions (Belgium, Czech Republic, Denmark, Finland, Germany, Ireland, Kazakhstan, Netherlands, Norway, Poland, Russian Federation, Slovakia, Sweden, Ukraine, United Kingdom, United States and Uzbekistan). It was decided to discuss at the next session the possibility of holding a workshop.

#### **XI. PROGRAMME OF WORK AND BIENNIAL EVALUATION** (agenda item 9)

Documents: ECE/TRANS/WP.11/2009/1, ECE/TRANS/WP.11/2009/3

49. The Working Party adopted its programme of work for 2010-2014 (ECE/TRANS/WP.11/2009/1) with the following modifications: (d) assign priority 1 and replace "Montreal Protocol" by "Copenhagen Conference", modify (f) to read "Updating of the ATP Handbook", (j) replace "2010" by "2010-2011", (k) replace "entry into force" by "adoption", (l) replace "2009" by "2010", and (n) replace "a text" by "proposals" (see Annex III to the present report). Finland requested that the subjects of containers and the sea crossing and inland waterways be added to the programme. The United Kingdom asked the secretariat to provide a definition of the priority ratings when the next programme of work was considered.

50. The Working Party adopted the biennial evaluation of its work presented in ECE/TRANS/WP.11/2009/3 and the proposal for 2010 to 2011 (see Annex III to the present report). It was proposed that in future, the indicators of achievement identified in the evaluation

should be more focused on measures to simplify or clarify the ATP and to reduce the burden of changes on industry. They should also distinguish between those proposals that were merely corrections and those that were genuine new proposals.

## **XII. RULES OF PROCEDURE** (agenda item 10)

Document: ECE/TRANS/WP.11/2009/6

51. At the 2008 session of WP.11, the secretariat had been requested to propose draft rules of procedure for WP.11 in a working document drawing inspiration from those developed for other Working Parties serviced by the Transport Division. The Working Party examined the draft terms of reference and rules of procedure submitted by the secretariat using those of the Working Party on the Transport of Dangerous Goods (WP.15) as a model (ECE/TRANS/WP.11/2009/6) and made the following comments on the text: reword Rule 9 so as not to suggest obligatory participation at sessions of WP.11, in Rule 12 delete "in the year" in the second sentence, in Rule 14 delete the second sentence, in Rule 25 clarify the meaning of "point of order", in Rule 28 clarify the meaning of the term "sense", in Rule 25 replace "a legal instrument in force" by "the ATP", and in Rule 37 replace "All elections shall be decided by secret ballot" by "All elections shall be decided by a show of hands".

52. Regarding Rule 4 relating to documentation, CLCCR recommended flexibility particularly with regard to working on informal documents which were usually not available in all three working languages. It was recommended that a Rule be added on the voting procedures and other relevant aspects regarding the ATP Handbook. In this regard, the United Kingdom offered to send comments in writing regarding clarification of the voting rules. The question of the quality of translations was also flagged as an important issue. One delegation stressed that it was not up to them to ensure the consistency of the different language versions of documents. It was suggested that the IIR's International Dictionary of Refrigeration and ISO standards were useful reference documents in this regard.

53. All delegates were invited to send their comments on the draft terms of reference and rules of procedure to the secretariat at their earliest convenience. A new draft would be prepared for adoption at the sixty-sixth session.

## **XIII. INLAND TRANSPORT SECURITY** (agenda item 11)

Documents: Informal document INF. 4

54. The Working Party examined the recommendations of the UNECE Multidisciplinary Group of Experts on Inland Transport Security (Informal document INF.4). The Working Party had no specific proposals regarding the introduction of security measures in the ATP other than those already undertaken on the securing of ATP documents to combat forgeries, but acknowledged that it might be necessary in the future to consider new approaches in the ATP including in the areas of quality, safety and security.

**XIV. ELECTION OF OFFICERS** (agenda item 12)

55. The Working Party elected Mr. T. Nobre (Portugal) as Chairman and Mr. G. Panozzo (Italy) as Vice-Chairman of WP.11 for 2010.

**XV. OTHER BUSINESS** (agenda item 13)

56. Under this item, delegates raised the issue of the frequency of calibration of temperature recorders according to the new text of Annex 2, Appendix 1 of the ATP which would enter into force on 6 December 2009. The representative of the Netherlands mentioned a new study which was being undertaken on the EU Directive on the length and weight of vehicles which might lead to longer refrigerated vehicles on the road. It was also proposed that the issue of the glossary to be included to the ATP Handbook be added to the agenda of the sixty-sixth session.

57. Delegates from Central Asian countries wished to express their profound appreciation to the European Commission which had funded the ATP project in Central Asia and to the consultants who had managed the project. The representative of Uzbekistan mentioned a problem with the use of the word "Special" in the title of the ATP. In the CIS countries this word had another meaning. He was asked to prepare a document for the sixty-sixth session explaining the issue.

58. The Working Party expressed its satisfaction with the technical visit which had been organized on 29 October to visit the European Centre for Nuclear Research (CERN) and asked the secretariat to send a letter of thanks to those who had organized the visit.

**Date of the next session**

59. The Working Party was informed that the dates of 9-12 November 2010 had been tentatively reserved for the sixty-sixth session of WP.11. All proposals for documents for the sixty-sixth session should be sent to the secretariat at the latest by 6 August 2010.

**XVI. ADOPTION OF THE REPORT** (agenda item 14)

60. The WP.11 adopted the report of its sixty-fifth session based on a draft prepared by the secretariat.



Annex I

**CORRECTION TO THE FRENCH TEXT OF ANNEX 1, APPENDIX 2 OF THE ATP**

**Annex 1, Appendix 2, para. 56 (b)**

For

"Si le compresseur frigorifique est entraîné par le **déplacement** du véhicule, l'essai sera effectué aux vitesses minimale et nominale de rotation du compresseur indiquées par le constructeur."

read

"Si le compresseur frigorifique est entraîné par le **moteur** du véhicule, l'essai sera effectué aux vitesses minimale et nominale de rotation du compresseur indiquées par le constructeur."

## Annex II

### ADDITIONS TO THE ATP HANDBOOK

1. Introduce the following comment after Annex 1, Appendix 1, paragraph 6 and add the accompanying graphic on page 19 of the present report to the Section of the ATP Handbook on Examples of Good Practice:

"Comment:

*ATP checklist*

*The following ATP checklist may serve as guidelines for verifying transport equipment used for the road transport of perishable foodstuffs. The ATP checklist includes basic information regarding the inspection of the isothermal properties of road transport equipment (certificate, certification plate, manufacturer's plate etc.) and the monitoring of air temperatures of quick-frozen perishable foodstuffs." (ECE/TRANS/WP.11/220, para. 39)*

2. Introduce the following comments after subparagraphs (a) and (b), paragraph 21 of Annex 1, Appendix 2, and add figures 1 and 2 on pages 20 and 21 of the present report to the Section of the ATP Handbook on Examples of Good Practice:

Comment to paragraph 21 (a):

"Comment:

*The layout of the placement of air temperature measuring devices inside and outside tanks with one compartment is shown in figure 1." (ECE/TRANS/WP.11/220, para. 40)*

Comment to paragraph 21 (b):

"Comment:

*The layout of the placement of air temperature measuring devices inside and outside tanks with three or more compartments is shown in figure 2."(ECE/TRANS/WP.11/220, para. 40)*

3. Introduce the following comment after subparagraph (b), paragraph 49 of Annex 1, Appendix 2:

"Comment:

*Failure to pass the efficiency test is in many cases due to lack of maintenance. To prevent unnecessary burden and additional costs for the owner-operator due to retests, it is strongly recommended that the thermal appliance be maintained properly and checked for correct functioning prior to the efficiency test." (ECE/TRANS/WP.11/220, para. 44)*

## GUIDELINES FOR VERIFICATION OF TRANSPORT EQUIPMENT USED FOR ROAD TRANSPORT OF PERISHABLE FOODSTUFFS

### INSPECTION OF ISOTHERMAL PROPERTIES OF ROAD TRANSPORT EQUIPMENT

Transport equipment has to be equipped with a valid certificate or a certification plate and a distinguishing mark.  
Examples of the most important identification data:

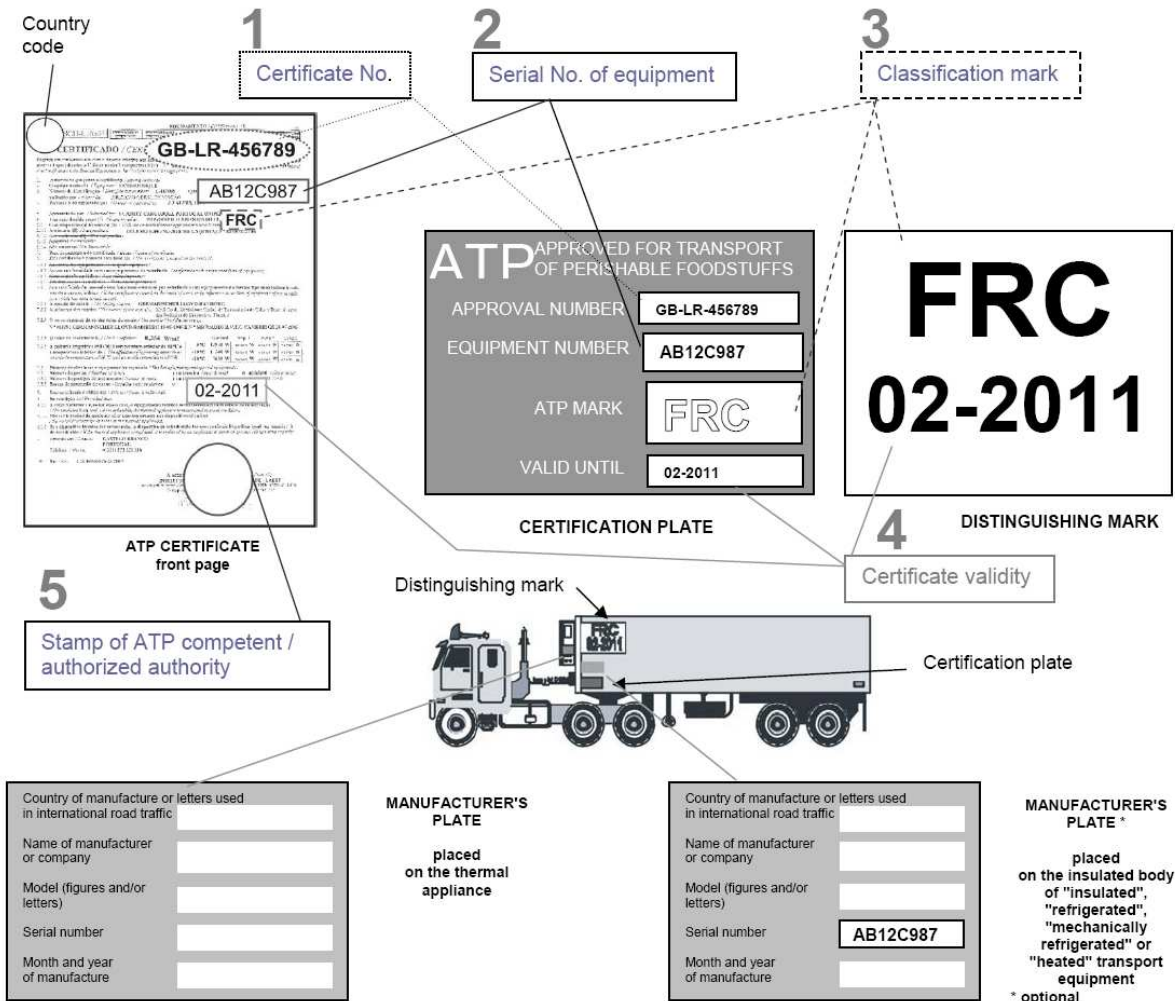

### MONITORING OF AIR TEMPERATURES FOR TRANSPORT OF QUICK-FROZEN PERISHABLE FOODSTUFFS

The transport equipment must be fitted with a suitable recording instrument to monitor, at frequent and regular intervals, the air temperatures to which quick-frozen foodstuffs intended for human consumption are subjected.

**CHECK:** Do the measuring instruments comply with standards EN 12830 and EN 13486? **YES / NO**  
Is the calibration certificate valid? **YES / NO**

Temperature recordings obtained in this manner must be dated and stored by the operator for at least one year or longer, according to the nature of the food. Measuring instruments shall comply with the provisions of this Appendix one year after the date of entry into force of the above provision. Measuring instruments already installed, but which do not conform to the above standards before this date, can continue to be used until 31 December 2009.

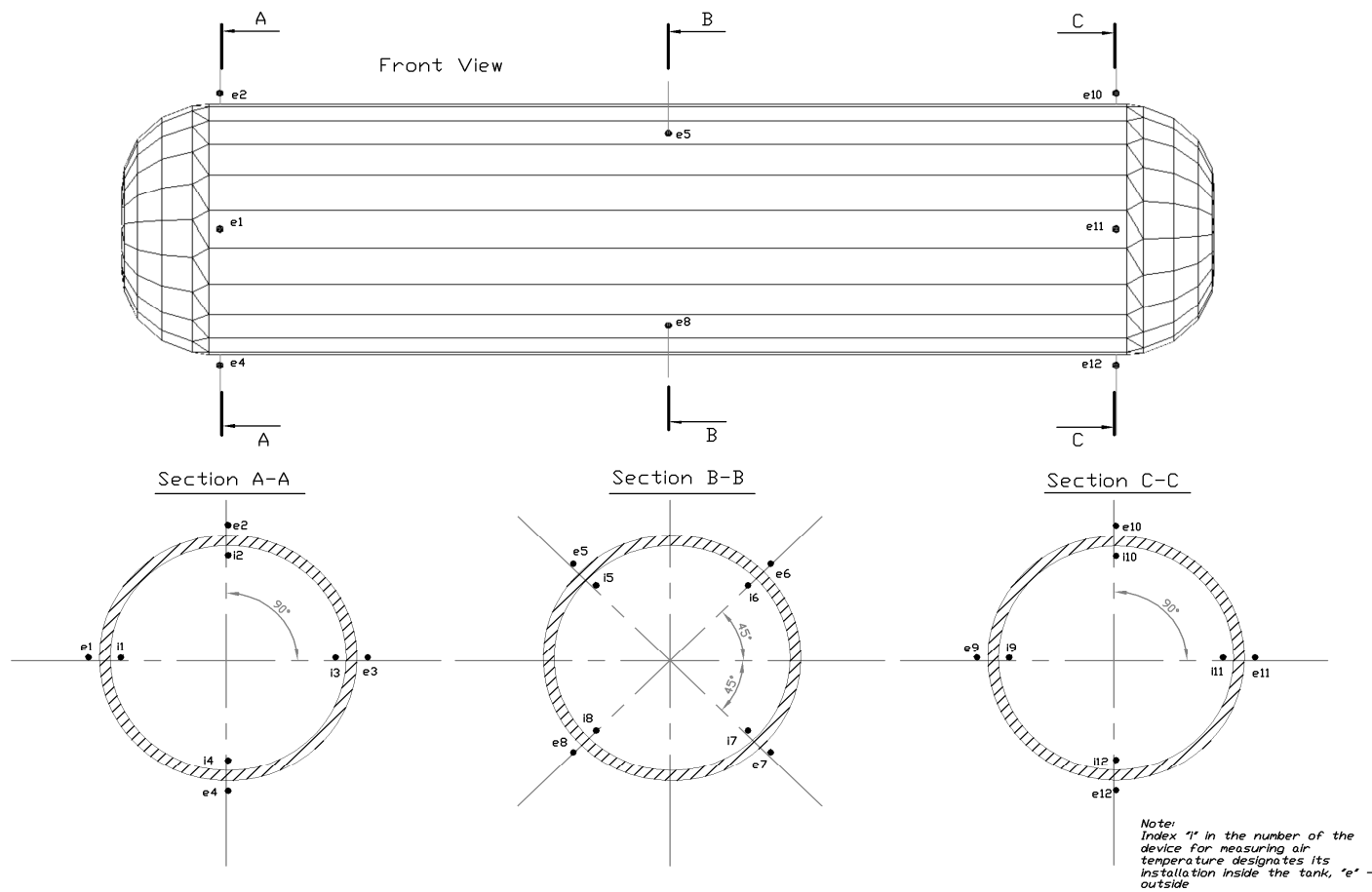

Figure 1

Scheme of accomodation of devices for measuring temperatures inside and outside tanks with one compartment

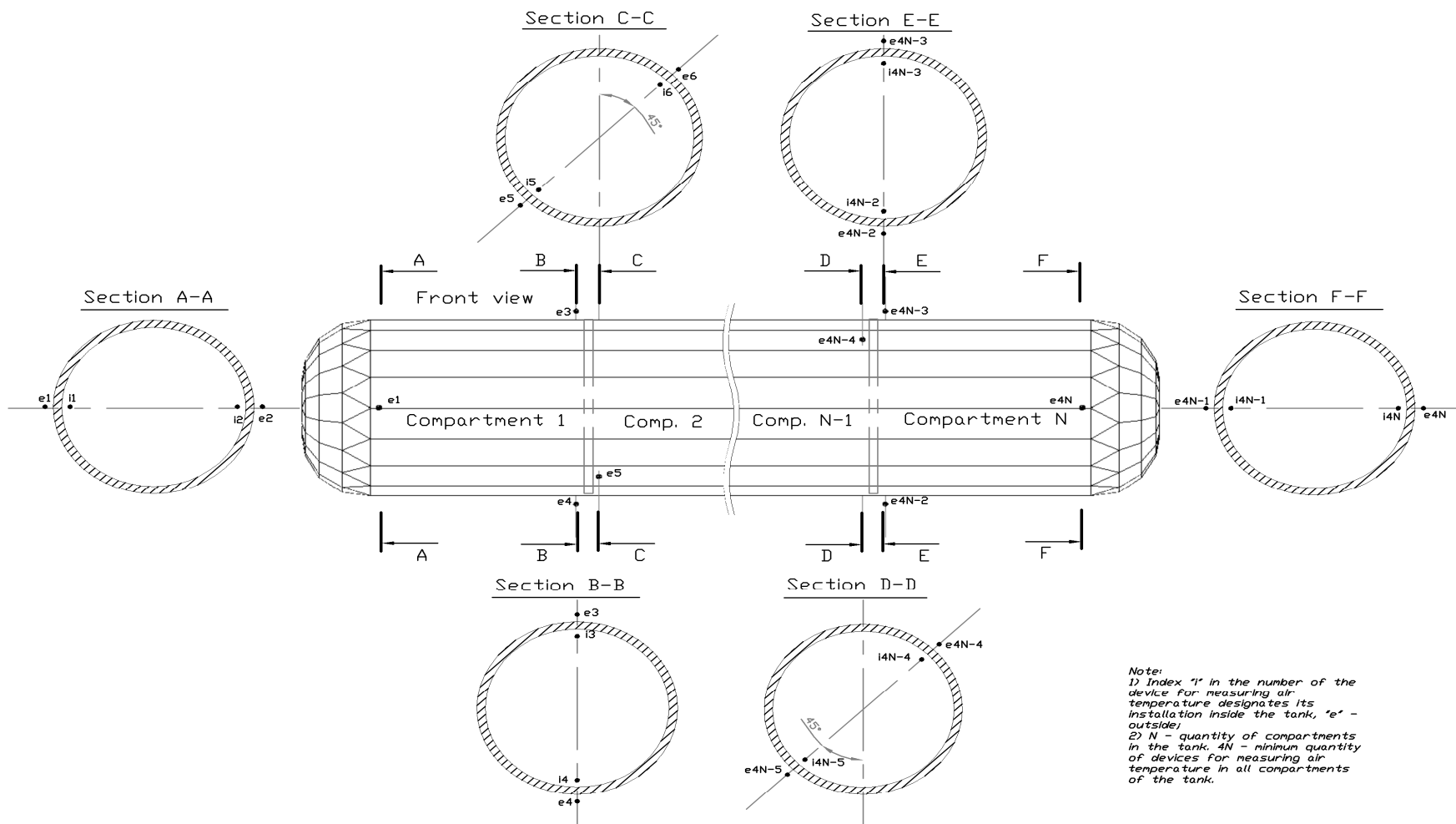

Figure 2

Scheme of accomodation of devices for measuring temperatures inside and outside tanks with three or more compartments.

### Annex III

#### DRAFT PROGRAMME OF WORK FOR 2010-2014 AND BIENNIAL EVALUATION 2010-2011

##### **Programme ACTIVITY 02.11: TRANSPORT OF PERISHABLE FOODSTUFFS**

Harmonization of regulations and standards relating to the international transport of perishable foodstuffs and facilitation of its operation Priority: 2

Description: Review of the harmonization and the facilitation of the international transport of perishable foodstuffs under the ATP Agreement and updating of the Agreement in order to keep it in line with technological and ecological developments, taking into account safety and quality standards.

Work to be undertaken:

##### **CONTINUING ACTIVITIES**

- (a) Consideration of amendment proposals to ATP to ensure it is updated as necessary. Priority: 1  
Output expected by the end of 2010: Entry into force of the revision of annexes 1 and 2 to ATP.
- (b) Exchange of information on the implementation of ATP by virtue of article 6. Priority: 1  
Output expected by the end of 2011: Consideration of the information exchanged between Contracting Parties and the consequences on the implementation of ATP.
- (c) Follow-up of resolution No. 243 on "Improving the traffic flow of ATP vehicles for the transport of foodstuffs covered by ATP" for better facilitation. Priority: 2  
Output expected by the end of 2011: To consider the difficulties encountered at border crossings for the transport of perishable foodstuffs, whenever necessary.
- (d) Review of the definitions and standards (in annex 1) for the carriage of perishable foodstuffs following the Copenhagen Conference to take account of new refrigerants and insulating materials, and environmental constraints. Priority: 1  
Output expected by the end of 2011: To contribute to the promotion of less polluting vehicles and fuels, through the possible holding of a workshop on ecological developments in the transport of perishable foodstuffs.
- (e) Consideration of the work of the IIR Sub-Commissions on testing stations and energy labelling. Priority: 1  
Output expected by the end of 2011: To be aware of the work done by IIR relating to the transport of perishable foodstuffs and to promote activities by WP.11 on energy labelling.
- (f) Updating of the ATP Handbook Priority: 1  
Output expected by the end of 2010: To have a version of the Handbook including the revised annexes.

- (g) Compatibility between European legislation and ATP. Priority: 1  
Output expected by the end of 2011: To cooperate with the European Commission with the aim of harmonizing European regulations with ATP.
- (h) Review of activities on the transport of perishable foodstuffs Priority: 1  
Output expected by the end of 2011: Adoption of the biennial evaluation of the work of WP.11 for submission to the Inland Transport Committee.
- (i) Promotion of ATP in countries not yet Contracting Parties in and outside the UNECE region with a view to promoting international safe trade in perishable foodstuffs. Priority: 2  
Output expected by the end of 2011: Presenting ATP in international conferences on harmonization and facilitation of international transport.

### **ACTIVITIES OF A LIMITED DURATION**

- (j) Consideration of proposals to extend the scope of ATP to cover the transport of fresh fruit and vegetables (2010) Priority: 2  
Output expected by the end of 2010-2011: To finish the consideration of the feasibility of introducing rules for the transport of fresh fruit and vegetables into ATP.
- (k) Consideration of amendment proposals relating to test methods and procedures for the approval of multi-compartment and multi temperature vehicles, to take account of technical developments (2010). Priority: 2  
Output expected by the end of 2010: The adoption of a new amendment to ATP on multi-compartment and multi-temperature vehicles.
- (l) Review of the treatment of kit bodies under ATP (2010). Priority: 2  
Output expected by the end of 2010: Common understanding among Contracting Parties of how kit bodies should be treated under ATP.
- (m) Securing of ATP documents (2010). Priority: 2  
Output expected by the end of 2010: Entry into force of new model ATP certificate and consideration of other ways of securing ATP documents.
- (n) Revision of ATP paragraphs 29 and 49 (2010). Priority: 2  
Output expected by the end of 2010: Drafting of proposals for the revision of ATP paragraphs 29 and 49.
- (o) Consideration of proposals to increase the length of the sea crossing referred to in ATP and to extend the scope of ATP to cover carriage by inland waterways (2010). Priority: 2  
Output expected by the end of 2010: Adoption of proposals.
- (p) Decision on whether to include new provisions in the ATP on thermal containers in the light of the proposals on the sea crossing and inland waterways (2010). Priority: 2  
Output expected by the end of 2010: Decision regarding thermal containers.

**BIENNIAL EVALUATION 2010-2011**

Cluster	Expected accomplishments	Indicators of achievement
Transport of perishable foodstuffs	Enhanced and updated international requirements for the transport of perishable foodstuffs	<p>(a) Number of new amendments to the ATP adopted by WP.11</p> <p>Performance measures:  Estimate: 2008-2009: 10  Target: 2010-2011: 10</p> <p>(b) Total number of Contracting Parties to the ATP Agreement</p> <p>Performance measures:  Estimate: 2008-2009: 45  Target: 2010-2011: 47</p> <p>(c) Number of documents considered at sessions of WP.11 and number of documents of amendment proposals transmitted to the United Nations Treaty Section in New York</p> <p>Performance measures:  Estimate: 2008-2009: 32 + 3  Target: 2010-2011: 32 + 3</p>

-----