

21 July 2008

## AGREEMENT

### CONCERNING THE ADOPTION OF UNIFORM TECHNICAL PRESCRIPTIONS FOR WHEELED VEHICLES, EQUIPMENT AND PARTS WHICH CAN BE FITTED AND/OR BE USED ON WHEELED VEHICLES AND THE CONDITIONS FOR RECIPROCAL RECOGNITION OF APPROVALS GRANTED ON THE BASIS OF THESE PRESCRIPTIONS \*/

(Revision 2, including the amendments which entered into force on 16 October 1995)

---

#### Addendum XYZ-1: Regulation No. XYZ

Date of entry into force: xy/ab/20cd

### UNIFORM PROVISIONS CONCERNING THE APPROVAL OF MOTOR VEHICLES WITH REGARD TO THEIR PEDESTRIAN SAFETY PERFORMANCE



UNITED NATIONS

---

\*/ Former title of the Agreement:

Agreement Concerning the Adoption of Uniform Conditions of Approval and Reciprocal Recognition of Approval for Motor Vehicle Equipment and Parts, done at Geneva on 20 March 1958.

Regulation No. XYZ

UNIFORM PROVISIONS CONCERNING THE APPROVAL OF MOTOR VEHICLES  
WITH REGARD TO THEIR PEDESTRIAN SAFETY PERFORMANCE

CONTENTS – to be finalized

REGULATION	<u>Page</u>
1. Scope .....	
2. Definitions .....	
3. Application for approval .....	
4. Approval .....	
5. Specifications .....	
6. Modification of vehicle type and extension of approval .....	
7. Conformity of production .....	
8. Penalties for non-conformity of production .....	
9. Production definitely discontinued .....	
10. Names and addresses of Technical Services responsible for conducting approval tests, and of Administrative Departments .....	
11. Introductory provisions .....	

ANNEXES

- Annex 1: Communication concerning the approval or extension or refusal or withdrawal of approval or production definitely discontinued of a type of vehicle with regard to the pedestrian safety performance pursuant to Regulation No. XYZ
- Annex 2: Arrangements of approval marks
- Annex 3: General test conditions
- Annex 4: Test impactor specifications

Annex 5: Test procedures

Annex 6: Certification of the impactors

Note: the whole structure corresponds to the "classical" UNECE structure, taking UNECE R125 as a basis.

## 1. SCOPE

This Regulation applies to motor vehicles of categories M<sub>1</sub> and N<sub>1</sub><sup>1/</sup>.

However, this Regulation does not apply to:

- a) vehicles of category N1 and,
- b) vehicles of category M1 above 2500 kg maximum mass and which are derived from N1 category vehicles,

where the driver's position "R-point" is either forward of the front axle or longitudinally rearwards of the front axle transverse centreline by a maximum of 1100 mm.

Scope taken from EU requirements

## 2. DEFINITIONS

When performing measurements as described in this Part, the vehicle should be positioned in its normal ride attitude.

If the vehicle is fitted with a badge, mascot or other structure, which would bend back or retract under an applied load of maximum 100 N, then this load shall be applied before and/or while these measurements are taken.

Any vehicle component which could change shape or position, other than suspension components or active devices to protect pedestrians, shall be set to their stowed position.

For the purposes of this Regulation:

Taken from gtr, § 3

- 2.1. "Adult headform test area" is an area on the outer surfaces of the front structure. The area is bounded, in the front, by a wrap around distance (WAD) of 1,700 mm and, at the rear, by the rear reference line for adult headform and, at each side, by the side reference line.

Copied from gtr, § 3.1.

---

<sup>1/</sup> As defined in Annex 7 to the Consolidated Resolution on the Construction of vehicles (R.E.3), document TRANS/WP.29/78/Rev.1/Amend.2, as last amended by Amendment 4.

- 2.2. "A-pillar" means the foremost and outermost roof support extending from the chassis to the roof of the vehicle  
Copied from gtr, § 3.2. Same as Council doc, Article 3
- 2.3. "Approval of a vehicle type" means the full procedure whereby a Contracting Party to the Agreement certifies that a vehicle type meets the technical requirements of this Regulation;
- 2.4. "Bonnet leading edge" means the edge of the front upper outer structure of the vehicle, including the bonnet and wings, the upper and side members of the headlight surrounds and any other attachments. The reference line identifying the position of the bonnet leading edge is defined by its height above the ground reference plane and by the horizontal distance separating it from the bumper (bumper lead).  
Copied from gtr, § 3.3. See also Council doc, Annex I, § 1.1.
- 2.5. "Bonnet leading edge height" means, at any point on the bonnet leading edge, the vertical distance between the ground reference plane and the bonnet leading edge reference line at that point.  
Copied from gtr, § 3.4. See also Commission doc, Annex I, § 2.1.
- 2.6. "Bonnet leading edge reference line" means the geometric trace of the points of contact between a straight edge 1 000 mm long and the front surface of the bonnet, when the straight edge, held parallel to the vertical longitudinal plane of the car and inclined rearwards by 50° from the vertical and with the lower end 600 mm above the ground, is traversed across and in contact with the bonnet leading edge (see Figure 1).

For vehicles having the bonnet top surface inclined at 50°, so that the straight edge makes a continuous contact or multiple contacts rather than a point contact, the reference line is determined with the straight edge inclined rearwards at an angle of 40° from the vertical.

For vehicles of such shape that the bottom end of the straight edge makes first contact, then that contact is taken to be the bonnet leading edge reference line, at that lateral position.

For vehicles of such shape that the top end of the straight edge makes first contact with the vehicle, then the geometric trace of 1 000 mm wrap around distance will be used as the bonnet leading edge reference line at that lateral position.

The top edge of the bumper shall also be regarded as the bonnet leading edge for the purposes of this Regulation, if it is contacted by the straight edge during this procedure.

Copied from gtr, § 3.5, with only very minor editorial edits. See also Council doc, Annex I, § 1.2.

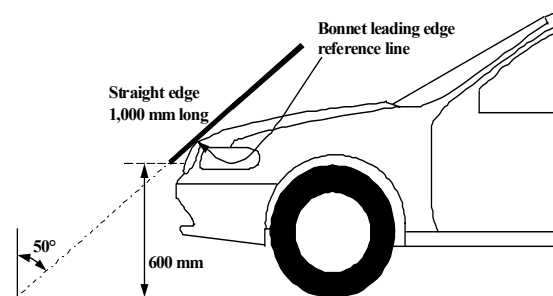

Figure 1: Bonnet leading edge reference line

- 2.7. "Bonnet rear reference line" means the geometric trace of the most rearward points of contact between a 165 mm diameter sphere and the front structure of the vehicle when the sphere is traversed across the front structure of the vehicle while maintaining contact with the windscreen (see Figure 2). The wiper blades and arms are removed during this process.

Where the bonnet rear reference line and the side reference line do not intersect, the bonnet rear reference line should be extended and/or modified using a semi-circular template, of radius 100 mm. The template should be made of a thin flexible sheet material that easily bends to a single curvature in any direction. The template should, preferably, resist double or complex curvature where this could result in wrinkling. The recommended material is a foam backed thin plastic sheet to allow the template to "grip" the surface of the vehicle.

The template should be marked up with four points "A" through "D", as shown in Figure 3, while the template is on a flat surface.

The template should be placed on the vehicle with Corners "A" and "B" coincident with the side reference line. Ensuring these two corners remain coincident with the side reference line, the template should be slid progressively rearwards until the arc of the template makes first contact with the bonnet rear reference line. Throughout the process, the template should be curved to follow, as closely as possible, the outer contour of the vehicle's bonnet top, without wrinkling or folding of the template. If the contact between the template and bonnet rear reference line is tangential and the point of tangency lies outside the arc scribed by points "C" and "D", then the bonnet rear reference line is extended and/or modified to follow the circumferential arc of the template to meet the bonnet side reference line, as shown in Figure 4.

If the template cannot make simultaneous contact with the bonnet side reference line at points "A" and "B" and tangentially with the bonnet rear reference line, or the point at which the bonnet rear reference line and template touch lies within the arc scribed by points "C" and "D", then additional templates should be used where the radii are increased progressively in increments of 20 mm, until all the above criteria are met.

Copied from gtr, § 3.6. See also Commission doc, Annex I, § 2.2 and 2.15.

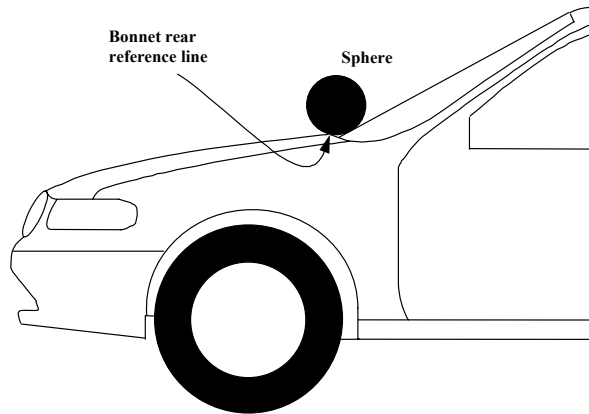

Figure 2: Bonnet rear reference line

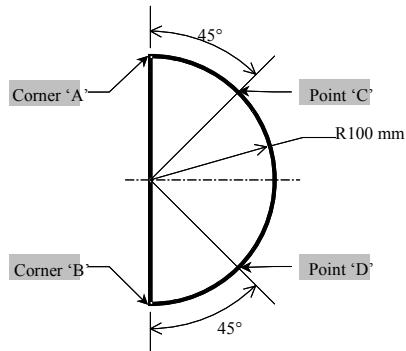

Figure 3: Template

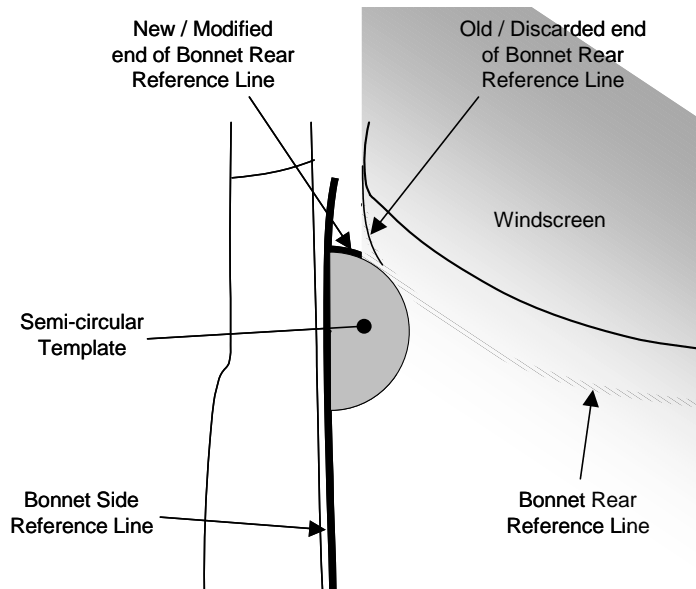

Figure 4: Marking of intersection between bonnet rear and side reference lines

2.8. "Bonnet top" is the area which is bounded by (a), (b) and (c) as follows:

- (a) the bonnet leading edge reference line;
- (b) the bonnet rear reference line;
- (c) the side reference lines.

Copied from gtr, § 3.7. See also Council doc, Annex I, § 1.4

2.9. "Bumper" means the front, lower, outer structure of a vehicle. It includes all structures that are intended to give protection to a vehicle when involved in a low speed frontal collision and also any attachments to this structure. The reference height and lateral limits of the bumper are identified by the corners and the bumper reference lines.

Copied from gtr, § 3.8. See also Council doc, Article 3

2.10. "Bumper lead" means for any longitudinal section of a vehicle, the horizontal distance measured in any vehicle vertical longitudinal plane between the upper bumper reference line and the bonnet leading edge reference line.

Copied from gtr, § 3.9. See also Commission doc, Annex I, § 2.4.

2.11. "Bumper test area" means the frontal surface of the bumper limited by two longitudinal vertical planes intersecting the corners of the bumper and moved 66 mm parallel and inboard of the corners of the bumpers.

Copied from gtr, § 3.10.

2.12. "Centre of the knee" of the lower legform impactor is defined as the point about which the knee effectively bends.

Copied from gtr, § 3.11.

2.13. "Child headform test area" is an area on the outer surfaces of the front structure. The area is bounded, in the front, by the front reference line for child headform, and, at the rear, by the WAD1700 line, and by the side reference lines.

Copied from gtr, § 3.12

2.14. "Corner of bumper" means the vehicle's point of contact with a vertical plane which makes an angle of 60° with the vertical longitudinal plane of the vehicle and is tangential to the outer surface of the bumper (see Figure 5).

Copied from gtr, § 3.13. Same as Commission doc, Annex I, § 2.5.



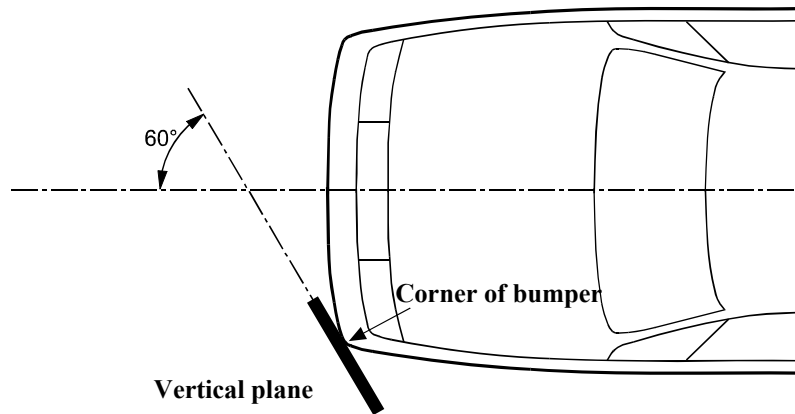

Figure 5: Corner of bumper

- 2.15. "Corner reference point" means the intersection of the bonnet leading edge reference line and of the bonnet side reference line (see Figure 6).  
Copied from Commission doc, Annex I, § 2.8. Is not included in the gtr.

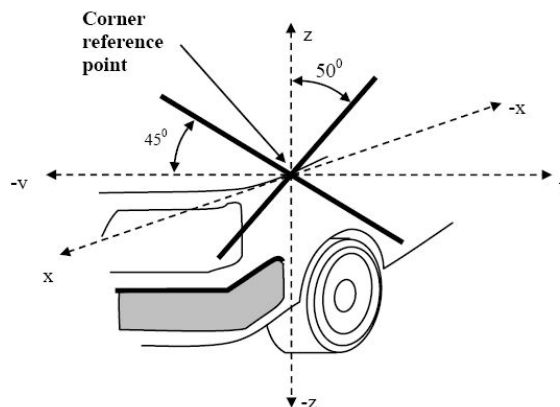

Figure 6: Determination of corner reference point; intersection of the bonnet leading edge reference line and the bonnet side reference line

- 2.16. "Driver Mass" means the nominal mass of a driver that shall be 75 kg (subdivided into 68 kg occupant mass at the seat and 7 kg luggage mass in accordance with ISO standard 2416–1992).  
Taken from SR1.
- 2.17. "Femur" of the lower legform impactor is defined as all components or parts of components (including flesh, skin covering, damper, instrumentation and brackets, pulleys, etc. attached to the impactor for the purpose of launching it) above the level of the centre of the knee.  
Copied from gtr, § 3.14.
- 2.18. "Front reference line for child headform" means the geometric trace as described on the vehicle front structure using a WAD1000 line. In the case of vehicles where the wrap around distance to the bonnet leading edge reference line, is more than 1,000 mm at any

point, then the bonnet leading edge reference line will be used as the front reference line for child headform at that point.

Copied from gtr, § 3.15

2.19. "Front structure" means all outer structures of the vehicle except the windscreen, the windscreen header, the A-pillars and structures rearward of these. It therefore includes, but is not limited to, the bumper, the bonnet, wings, scuttle, wiper spindles and lower windscreen frame.

Copied from gtr, § 3.16. See also Council document, Annex I, § 1.5

2.20. "Ground reference plane" means a horizontal plane, either real or imaginary, that passes through the lowest points of contact for all tyres of a vehicle while the vehicle is in its normal ride attitude. If the vehicle is resting on the ground, then the ground level and the ground reference plane are one and the same. If the vehicle is raised off the ground such as to allow extra clearance below the bumper, then the ground reference plane is above ground level.

Copied from gtr, § 3.17.

2.21. "Head Injury Criterion (HIC)" means the calculated result of accelerometer time histories using the following formula:

$$\text{HIC} = \left[ \frac{1}{t_2 - t_1} \int_{t_1}^{t_2} a \, dt \right]^{2.5} (t_2 - t_1)$$

Where:

- a is the resultant acceleration measured in units of gravity "g" (1 g = 9.81 m/s<sup>2</sup>);
- t<sub>1</sub> and t<sub>2</sub> are the two time instants (expressed in seconds) during the impact, defining an interval between the beginning and the end of the recording period for which the value of HIC is a maximum (t<sub>2</sub> - t<sub>1</sub> ≤ 15 ms)

Copied from gtr, § 3.18. See also Council doc, Annex I, § 1.9.

2.22. "Impact point" means the point on the vehicle where initial contact by the test impactor occurs. The proximity of this point to the target point is dependent upon both the angle of travel by the test impactor and the contour of the vehicle surface (see point B in Figure 7).

Copied from gtr, § 3.19.

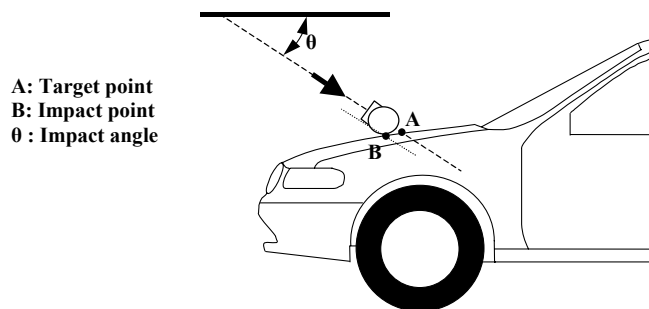

Figure 7: Impact and target point

2.23. "Lower bumper height" means the vertical distance between the ground reference plane and the lower bumper reference line, with the vehicle positioned in its normal ride attitude.

Copied from gtr, § 3.20. See also Commission doc, Annex I, § 2.1. . See also Commission doc, Annex I, § 2.17.

2.24. "Lower bumper reference line" means the lower limit to significant points of pedestrian contact with the bumper. It is defined as the geometric trace of the lowermost points of contact between a straight edge 700 mm long and the bumper, when the straight edge, held parallel to the vertical longitudinal plane of the vehicle and inclined forwards by 25° from the vertical, is traversed across the front of the vehicle, while maintaining contact with the ground and with the surface of the bumper (see Figure 8).

Copied from gtr, § 3.21, with a minor editorial edit (replace "car" by "vehicle"). See also Commission doc, Annex I, § 2.16.

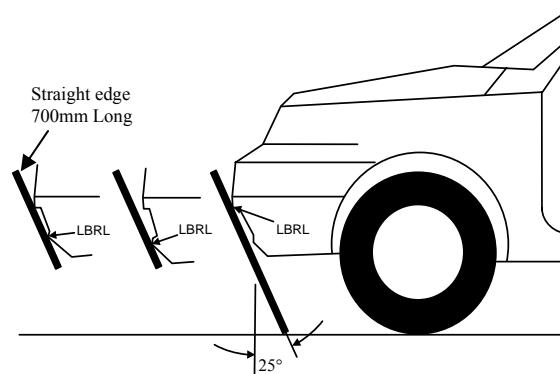

Figure 8: Lower bumper reference line, LBRL

2.25. "Mass in running order" means the nominal mass of a vehicle as determined by the sum of unladen vehicle mass and driver's mass.

Taken from SR1, but with edits since Cat 1-2 is same as M2/M3, not part of scope !

2.26. "Normal ride attitude" means the vehicle positioned on a flat horizontal surface with its mass in running order, with the tyres inflated to manufacturer recommended pressures, the front wheels in the straight-ahead position and with a passenger mass placed on the

front passenger seat. The front seats are placed at the nominal mid-track position. The suspension shall be set in normal running condition as specified by the manufacturer for a speed of 40 km/h.

Copied from gtr, § 3.22, but with edits since we cannot refer to Special Resolution? See also Council doc, Annex I, § 1.7.

2.27. "Passenger mass" means the nominal mass of a passenger that shall be 68 kg, with in addition a 7 kg provision for luggage which shall be located in the luggage compartment(s) in accordance with ISO standard 2416–1992.

Taken from SR1, but with edits.

2.28. "Side reference line" means the geometric trace of the highest points of contact between a straight edge 700 mm long and the sides of the vehicle, when the straight edge, held parallel to the transverse vertical plane of the vehicle and inclined inwards by 45°, is traversed down, and maintains contact with the sides of the front structure (see Figure 9).

Copied from gtr, § 3.24. See also Commission doc, Annex I, § 2.3.

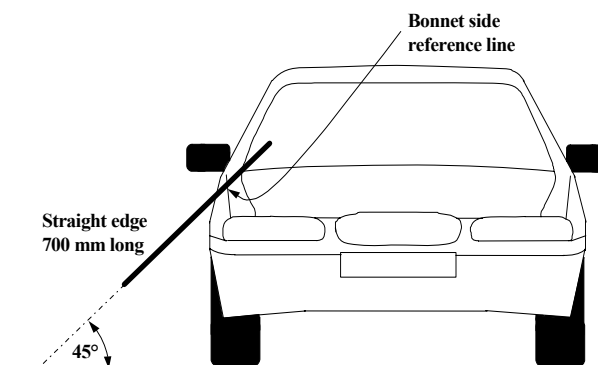

Figure 9: Side reference line

2.29. "Target point" means the intersection of the projection of the headform longitudinal axis with the front surface of the vehicle (see point A in Figure 7.).

Copied from gtr, § 3.25.

2.30. "Third of the bonnet leading edge" means the geometric trace between the corner reference points, measured with a flexible tape following the outer contour of the leading edge, divided in three equal parts.

Copied from Commission doc, Annex I, § 2.21. Is not included in the gtr.

2.31. "Third of the bonnet top" means the geometric trace of the area between the bonnet side reference lines, measured with a flexible tape following the outer contour of the bonnet top on any transverse section, divided in three equal parts.

Copied from Commission doc, Annex I, § 2.22. Is not included in the gtr.

- 2.32. "Third of the bumper" means the geometric trace between the corners of the bumper, measured with a flexible tape following the outer contour of the bumper, divided in three equal parts.  
Copied from Commission doc, Annex I, § 2.25. Is not included in the gtr.
- 2.33. "Tibia" of the lower legform impactor is defined as all components or parts of components (including flesh, skin covering, instrumentation and brackets, pulleys, etc. attached to the impactor for the purpose of launching it) below the level of the centre of the knee. Note that the tibia as defined includes allowances for the mass, etc., of the foot.  
Copied from gtr, § 3.26.
- 2.34. "Unladen Vehicle Mass" means the nominal mass of a complete vehicle as determined by the following criteria:
- 2.34.1. Mass of the vehicle with bodywork and all factory fitted equipment, electrical and auxiliary equipment for normal operation of vehicle, including liquids, tools, fire extinguisher, standard spare parts, chocks and spare wheel, if fitted.
- 2.34.2. The fuel tank shall be filled to at least 90 per cent of rated capacity and the other liquid containing systems (except those for used water) to 100 per cent of the capacity specified by the manufacturer  
Taken from SR1.
- 2.35. "Upper bumper reference line" means a line which identifies the upper limit to significant points of pedestrian contact with the bumper. It is defined as the geometric trace of the upper most points of contact between a straight edge 700 mm long and the bumper, when the straight edge, held parallel to the vertical longitudinal plane and inclined rearwards by 20°, is traversed across the front of the vehicle, while maintaining contact with the ground and with the surface of the bumper (see Figure 10).

Where necessary the straight edge shall be shortened to avoid any contact with structures above the bumper.

Copied from Commission doc, Annex I, § 2.27, since it seems better and clearer than gtr, § 3.27

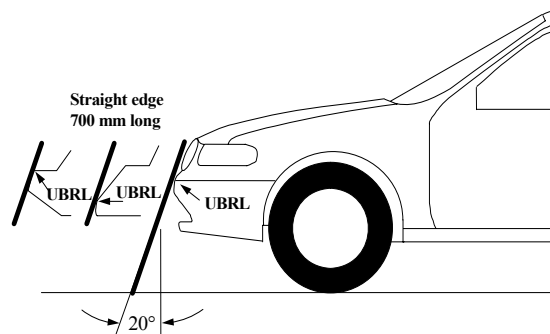

Figure 10: Upper bumper reference line, UBRL

2.36. "Vehicle type with regard to the pedestrian protection requirements" means a category of vehicles which, forward of the A-pillars, do not differ in such essential respects as:

- the structure,
- the main dimensions,
- the materials of the outer surfaces of the vehicle,
- the component arrangement (external or internal),

in so far as they may be considered to have a negative effect on the results of the impact tests prescribed in this Regulation.

Note: taken from Commission working document, Annex 1, § 2.30 with edits.

2.37. "Vehicles of category M1 derived from N1" means those vehicles of M1 category which, forward of the A-pillar, have the same general structure and shape as a pre-existing N1 category vehicle.

Copied from Council doc, Article 3

2.38. "Vehicles of category N1 derived from M1" means those vehicles of N1 category which, forward of the A-pillars, have the same general structure and shape as a pre-existing M1 category vehicle.

Copied from Council doc, Article 3

2.39. "Windscreen" means the frontal glazing of the vehicle situated between the A-pillars.

Copied from gtr, § 3.29. See also Council doc, Annex I, § 1.8.

2.40. "Wrap Around Distance (WAD)" means the geometric trace described on the outer surface of the vehicle front structure by one end of a flexible tape, when it is held in a vertical longitudinal plane of the vehicle and traversed across the front structure. The tape is held taut throughout the operation with one end held at the same level as the ground reference plane, vertically below the front face of the bumper and the other end held in contact with the front structure (see Figure 11). The vehicle is positioned in the normal ride attitude.

This procedure shall be followed, using alternative tapes of appropriate lengths, to describe wrap around distances of 1,000 mm (WAD1000), of 1,700 mm (WAD1700) and of 2,100 mm (WAD2100).

Copied from gtr, § 3.28, with only very minor editorial edits. See also Council doc, Annex I, § 1.3

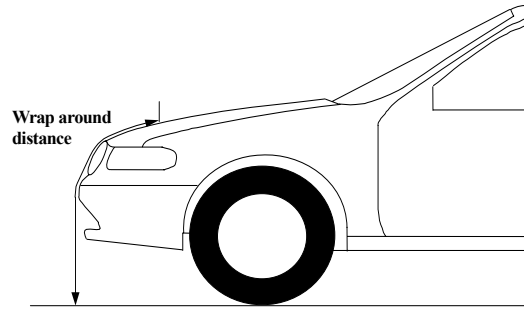

Figure 11: Wrap around distance measurement

### 3. APPLICATION FOR APPROVAL

- 3.1. The application for approval of a vehicle type with regard to the pedestrian protection requirements shall be submitted by the vehicle manufacturer or by his authorized representative.
- 3.2. It shall be accompanied by the documents mentioned below in triplicate and include the following particulars:
  - 3.2.1. a description of the vehicle type with regard to the items mentioned in paragraph 2.37., together with dimensional drawings. The numbers and/or symbols identifying the vehicle type shall be specified.
- 3.3. A vehicle representative of the vehicle type to be approved shall be submitted to the Technical Service conducting the approval tests.

### 4. APPROVAL

- 4.1. If the vehicle type submitted for approval pursuant to this Regulation meets the requirements of paragraph 5. below, approval of that vehicle shall be granted.
- 4.2. An approval number shall be assigned to each type approved; its first two digits (00 for the Regulation in its initial form) shall indicate the series of amendments incorporating the most recent major technical amendments made to the Regulation at the time of issue of the approval. The same Contracting Party shall not assign the same number to another vehicle type.
- 4.3. Notice of approval or of refusal or withdrawal of approval pursuant to this Regulation shall be communicated to the Parties to the Agreement which apply this Regulation by means of a form conforming to the model in Annex 1 and photographs and/or plans supplied by the applicant being in a format not exceeding A4 (210 x 297 mm), or folded to that format, and on an appropriate scale.
- 4.4. There shall be affixed, conspicuously and in a readily accessible place specified on the approval form, to every vehicle conforming to a vehicle type approved under this Regulation, an international approval mark conforming to the model described in Annex 2, consisting of:
  - 4.4.1. a circle surrounding the letter "E" followed by the distinguishing number of the country which has granted approval <sup>2/</sup>;

---

<sup>2/</sup> 1 for Germany, 2 for France, 3 for Italy, 4 for the Netherlands, 5 for Sweden, 6 for Belgium, 7 for Hungary, 8 for the Czech Republic, 9 for Spain, 10 for Serbia, 11 for the United Kingdom,



- 4.4.2. the number of this Regulation, followed by the letter "R", a dash and the approval number to the right of the circle prescribed in paragraph 4.4.1. above.
- 4.5. If the vehicle conforms to a vehicle type approved under one or more other Regulations, annexed to the Agreement, in the country which has granted approval under this Regulation, the symbol prescribed in paragraph 4.4.1. need not be repeated; in such a case, the Regulation and approval numbers and the additional symbols shall be placed in vertical columns to the right of the symbol prescribed in paragraph 4.4.1. above.
- 4.6. The approval mark shall be clearly legible and be indelible.
- 4.7. The approval mark shall be placed close to or on the vehicle data plate.

---

12 for Austria, 13 for Luxembourg, 14 for Switzerland, 15 (vacant), 16 for Norway, 17 for Finland, 18 for Denmark, 19 for Romania, 20 for Poland, 21 for Portugal, 22 for the Russian Federation, 23 for Greece, 24 for Ireland, 25 for Croatia, 26 for Slovenia, 27 for Slovakia, 28 for Belarus, 29 for Estonia, 30 (vacant), 31 for Bosnia and Herzegovina, 32 for Latvia, 33 (vacant), 34 for Bulgaria, 35 (vacant), 36 for Lithuania, 37 for Turkey, 38 (vacant), 39 for Azerbaijan, 40 for The former Yugoslav Republic of Macedonia, 41 (vacant), 42 for the European Community (Approvals are granted by its Member States using their respective ECE symbol), 43 for Japan, 44 (vacant), 45 for Australia, 46 for Ukraine, 47 for South Africa, 48 for New Zealand, 49 for Cyprus, 50 for Malta, 51 for the Republic of Korea, 52 for Malaysia, 53 for Thailand, 54 and 55 (vacant) and 56 for Montenegro. Subsequent numbers shall be assigned to other countries in the chronological order in which they ratify or accede to the Agreement Concerning the Adoption of Uniform Technical Prescriptions for Wheeled Vehicles, Equipment and Parts which can be Fitted and/or be Used on Wheeled Vehicles and the Conditions for Reciprocal Recognition of Approvals Granted on the Basis of these Prescriptions, and the numbers thus assigned shall be communicated by the Secretary-General of the United Nations to the Contracting Parties to the Agreement.

**Note: this should be checked by the UN secretariat.**

## 5. SPECIFICATIONS

### 5.1. Legform test to bumper:

For vehicles with a lower bumper height of less than 425 mm the requirements of paragraph 5.1.1. shall be applied.

For vehicles with a lower bumper height which is greater than, or equal to, 425 mm and less than 500 mm the requirements of either paragraph 5.1.1. or 5.1.2., at the choice of the manufacturer, shall be applied.

For vehicles with a lower bumper height of greater than, or equal to, 500 mm the requirements of paragraph 5.1.2. shall be applied.

Taken from gtr, § 4.1

#### 5.1.1. Lower legform to bumper:

When tested in accordance with Annex 5, paragraph 1 (lower legform to bumper), the maximum dynamic knee bending angle shall not exceed 19°, the maximum dynamic knee shearing displacement shall not exceed 6.0 mm, and the acceleration measured at the upper end of the tibia shall not exceed 170g. In addition, the manufacturer may nominate bumper test widths up to a maximum of 264 mm in total where the acceleration measured at the upper end of the tibia shall not exceed 250g.

Taken from gtr, § 5.1.1.

The lower legform impactor shall be certified pursuant to Annex 5, paragraph 1.

New sentence added to clarify the impactor must be certified.

#### 5.1.2. Upper legform to bumper:

When tested in accordance with Annex 5, paragraph 2 (upper legform to bumper), the instantaneous sum of the impact forces with respect to time shall not exceed 7.5 kN and the bending moment on the test impactor shall not exceed 510 Nm.

Taken from gtr, § 5.1.2.

The upper legform impactor shall be certified pursuant to Annex 5, paragraph 2.

New sentence added to clarify the impactor must be certified.

### 5.2. Headform tests

#### 5.2.1. Child and adult headform tests:

When tested in accordance with Annex 5, paragraphs 3, 4, and 5, the HIC recorded shall not exceed 1,000 over two thirds of the combined child and adult headform test areas. The HIC for the remaining areas shall not exceed 1,700 for both headforms.

In case there is only a child headform test area, the HIC recorded shall not exceed 1,000 over two thirds of the test area. For the remaining area the HIC shall not exceed 1,700. Based on the combination from gtr, § 5.2.1, 5.2.2, and 5.2.3. Specific requirements for child area: see 5.2.2.

- 5.2.2. Child headform impact:  
When tested in accordance with Annex 5, paragraphs 3 and 4, the HIC recorded shall not exceed 1,000 over a minimum of one half of the child headform test area. The HIC for the remaining areas shall not exceed 1,700.  
Based on gtr, § 5.2.3.
- 5.2.3. The headform impactors shall be certified pursuant to Annex 5, paragraph 3.  
New § added to clarify the impactor must be certified.

## 6. MODIFICATION OF VEHICLE TYPE AND EXTENSION OF APPROVAL

- 6.1. Every modification of the vehicle type as defined in paragraph 2.37. above shall be notified to the Administrative Department which approved the vehicle type. The department may then either:
- 6.1.1. consider that the modifications made do not have an adverse effect on the conditions of the granting of the approval and grant an extension of approval;
- 6.1.2. consider that the modifications made affect the conditions of the granting of the approval and require further tests or additional checks before granting an extension of approval.
- 6.2. Confirmation or refusal of approval, specifying the alterations, shall be communicated by the procedure specified in paragraph 4.3. above to the Contracting Parties to the Agreement which apply this Regulation.
- 6.3. The Competent Authority shall inform the other Contracting Parties of the extension by means of the communication form which appears in Annex 2 to this Regulation. It shall assign a serial number to each extension, to be known as the extension number.

## 7. CONFORMITY OF PRODUCTION

- 7.1. Procedures concerning conformity of production shall conform to the general provisions defined in Appendix 2 to the Agreement (E/ECE/324-E/ECE/TRANS/505/Rev.2) and meet the following requirements:

7.2. A vehicle approved pursuant to this Regulation shall be so manufactured as to conform to the type approved by meeting the requirements of paragraph 5. above;

7.3. The Competent Authority which has granted approval may at any time verify the conformity of control methods applicable to each production unit. The normal frequency of such inspections shall be once every two years.

## 8. PENALTIES FOR NON-CONFORMITY OF PRODUCTION

8.1. The approval granted in respect of a vehicle type pursuant to this Regulation may be withdrawn if the requirements laid down in paragraph 8. above are not complied with.

8.2. If a Contracting Party withdraws an approval it had previously granted, it shall forthwith so notify the other Contracting Parties applying this Regulation by sending them a communication form conforming to the model in Annex 1 to this Regulation.

## 9. PRODUCTION DEFINITELY DISCONTINUED

If the holder of the approval completely ceases to manufacture a type of vehicle approved in accordance with this Regulation, he shall so inform the authority which granted the approval, which in turn shall forthwith inform the other Contracting Parties to the Agreement applying this Regulation by means of a communication form conforming to the model in Annex 1 to this Regulation.

## 10. NAMES AND ADDRESSES OF THE TECHNICAL SERVICES RESPONSIBLE FOR CONDUCTING APPROVAL TESTS AND OF ADMINISTRATIVE DEPARTMENTS

The Contracting Parties to the Agreement applying this Regulation shall communicate to the United Nations Secretariat the names and addresses of the Technical Services responsible for conducting approval tests and of the Administrative Departments which grant approval and to which forms certifying approval or extension or refusal or withdrawal of approval are to be sent.

## 11. INTRODUCTORY PROVISIONS

11.1. As from the date of entry into force of this Regulation, Contracting Parties applying this Regulation shall not:

- a) Refuse to grant ECE approval for a vehicle type under this Regulation,

- b) Prohibit the sale or entry into service of a type of vehicle with regard to its pedestrian safety performance,

if the vehicle type complies with the requirements of this Regulation.

- 11.2. Vehicles of category M1 not exceeding 2500 kg GVM, and vehicles of category N1 derived from them ~~these former M1 vehicles~~
- 11.2.1 As from [1 January 2013] [[30] months after the date of entry into force], Contracting Parties applying this Regulation shall grant approvals only if the vehicle type to be approved meets the requirements of this Regulation.
- 11.2.2 As from [1 January 2018] [[90] months after the date of entry into force], Contracting Parties applying this Regulation may refuse first national or regional registration (first entry into service) of a vehicle which does not meet the requirements of this Regulation.
- 11.3. Vehicles of category M1 exceeding 2500 kg GVM, as well as vehicles of category N1, other than those of paragraph 11.2
- 11.3.1. As from [1 Jan 2015] [[54] months after the date of entry into force], Contracting Parties applying this Regulation shall grant approvals only if the vehicle type to be approved meets the requirements of this Regulation.
- 11.3.2. As from [1 July 2019] [[108] months after the date of entry into force], Contracting Parties applying this Regulation may refuse first national or regional registration (first entry into service) of a vehicle which does not meet the requirements of this Regulation.

Annex 1

COMMUNICATION

(Maximum format: A4 (210 x 297 mm))



issued by :

Name of administration:

.....  
.....  
.....

concerning: 2/

- APPROVAL GRANTED
- APPROVAL EXTENDED
- APPROVAL REFUSED
- APPROVAL WITHDRAWN
- PRODUCTION DEFINITELY DISCONTINUED

of a type of vehicle with regard to the pedestrian safety performance pursuant to Regulation No. XYZ

Approval No.: ..... Extension No.: .....

1. Trademark: .....
2. Type and trade name(s): .....
3. Name and address of manufacturer: .....
4. If applicable, name and address of manufacturer's representative: .....
5. Brief description of vehicle: .....
6. Date of submission of vehicle for approval: .....
7. Technical Service performing the approval tests: .....
8. Date of report issued by that service: .....
9. Number of report issued by that service: .....
10. Approval with regard to the pedestrian safety performance is granted/refused: 2/ .....

11. Place: .....
12. Date: .....
13. Signature: .....
14. Annexed to this communication are the following documents, bearing the approval number indicated above:
- ..... dimensional drawings
- ..... exploded view or photograph of the vehicle
15. Any remarks: .....

1/ Distinguishing number of the country which has granted/extended/refused/withdrawn an approval (see approval provisions in the Regulation).

2/ Delete what does not apply.

Annex 2

ARRANGEMENTS OF APPROVAL MARKS

(see paragraphs 4.4. to 4.4.2 of this Regulation)

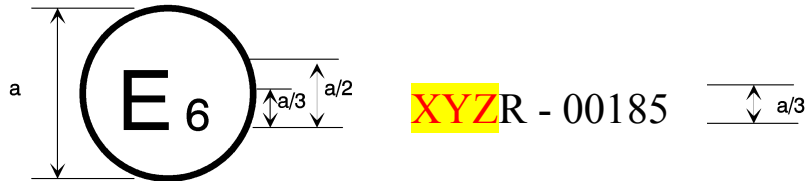

$a = 8 \text{ mm min}$

The above approval mark affixed to a vehicle shows that the vehicle type concerned has been approved in Belgium (E6) with regard to its pedestrian safety performance pursuant to Regulation No. XYZ. The first two digits of the approval number indicate that the approval was granted in accordance with the requirements of Regulation No. XYZ in its original form.



### Annex 3

#### GENERAL TEST CONDITIONS

This Annex copies gtr, § 6.1.1 to 6.2.3

1. Temperature and humidity
  - 1.1. At the time of testing, the test facility and the vehicle or sub-system shall have a relative humidity of 40 percent  $\pm$  30 percent and stabilized temperature of 20 + 4 °C.
2. Impact test site
  - 2.1. The test site shall consist of a flat, smooth and hard surface with a slope not exceeding 1 percent.
3. Preparation of the vehicle
  - 3.1. Either a complete vehicle, or a cut-body, adjusted to the following conditions shall be used for the test.
    - 3.1.1. The vehicle shall be in its normal ride attitude, and shall be either securely mounted on raised supports or at rest on a flat horizontal surface with the parking brake applied.
    - 3.1.2. The cut-body shall include, in the test, all parts of the vehicle front structure, all under-bonnet components and all components behind the windscreen that may be involved in a frontal impact with a vulnerable road user, to demonstrate the performance and interactions of all the contributory vehicle components. The cut-body shall be securely mounted in the normal vehicle ride attitude.
  - 3.2. All devices designed to protect vulnerable road users when impacted by the vehicle shall be correctly activated before and/or be active during the relevant test. It shall be the responsibility of the manufacturer to show that any devices will act as intended in a pedestrian impact.
  - 3.3. For vehicle components which could change shape or position, other than active devices to protect pedestrians, and which have more than one fixed shape or position shall require the vehicle to comply with the components in each fixed shape or position.

## Annex 4

### TEST IMPACTOR SPECIFICATIONS

This Annex is based on gtr, § 6.3, however only retaining the "pure" specifications – all items related to the procedures are in a separate annex

#### 1. Lower legform impactor

- 1.1. The lower legform impactor shall consist of two foam covered rigid segments, representing femur (upper leg) and tibia (lower leg), joined by a deformable, simulated knee joint. The overall length of the impactor shall be  $926 \pm 5$  mm, having a required test mass of  $13.4 \pm 0.2$  kg (see Figure 12). **Dimensions of the various parts are detailed in Figure 12.**

Brackets, pulleys, etc. attached to the impactor for the purpose of launching it, may extend the dimensions shown in Figure 12.

Taken from gtr, § 6.3.1.1 with addition of a sentence (see in red).

- 1.2. The diameter of the femur and tibia shall be  $70 \pm 1$  mm and both shall be covered by foam flesh and skin. The foam flesh shall be 25 mm thick foam type CF-45 or equivalent. The skin shall be made of neoprene foam, faced with 0.5 mm thick nylon cloth on both sides, with an overall thickness of 6 mm.

Taken from gtr, § 6.3.1.1.1

- 1.3. The knee joint shall be fitted with deformable knee elements from the same batch as those used in the certification tests.

Taken from gtr, § 6.3.1.1.2

- 1.4. The total masses of the femur and tibia shall be  $8.6 \pm 0.1$  kg and  $4.8 \pm 0.1$  kg respectively, and the total mass of the impactor shall be  $13.4 \pm 0.2$  kg. The centre of gravity of the femur and tibia shall be  $217 \pm 10$  mm and  $233 \pm 10$  mm from the centre of the knee respectively. The moment of inertia of the femur and tibia, about a horizontal axis through the respective centre of gravity and perpendicular to the direction of impact, shall be  $0.127 \pm 0.010$  kgm<sup>2</sup> and  $0.120 \pm 0.010$  kgm<sup>2</sup> respectively.

Taken from gtr, § 6.3.1.1.3

#### 2. Lower legform instrumentation

- 2.1. An uniaxial accelerometer shall be mounted on the non-impacted side of the tibia,  $66 \pm 5$  mm below the knee joint centre, with its sensitive axis in the direction of impact.

Taken from gtr, § 6.3.1.1.6.1

2.2. A damper shall be fitted to the shear displacement system and may be mounted at any point on the rear face of the impactor or internally. The damper properties shall be such that the impactor meets both the static and dynamic shear displacement requirements and prevents excessive vibrations of the shear displacement system.

Taken from gtr, § 6.3.1.1.6.2

2.3. Transducers shall be fitted to measure knee bending angle and knee shearing displacement.

Taken from gtr, § 6.3.1.1.6.3

2.4. The instrumentation response value channel frequency class (CFC), as defined in ISO 6487:2002, shall be 180 for all transducers. The CAC response values, as defined in ISO 6487:2002, shall be 50° for the knee bending angle, 10 mm for the shearing displacement and 500g for the acceleration. This does not require that the impactor itself be able to physically bend and shear to these angles and displacements.

Taken from gtr, § 6.3.1.1.6.4

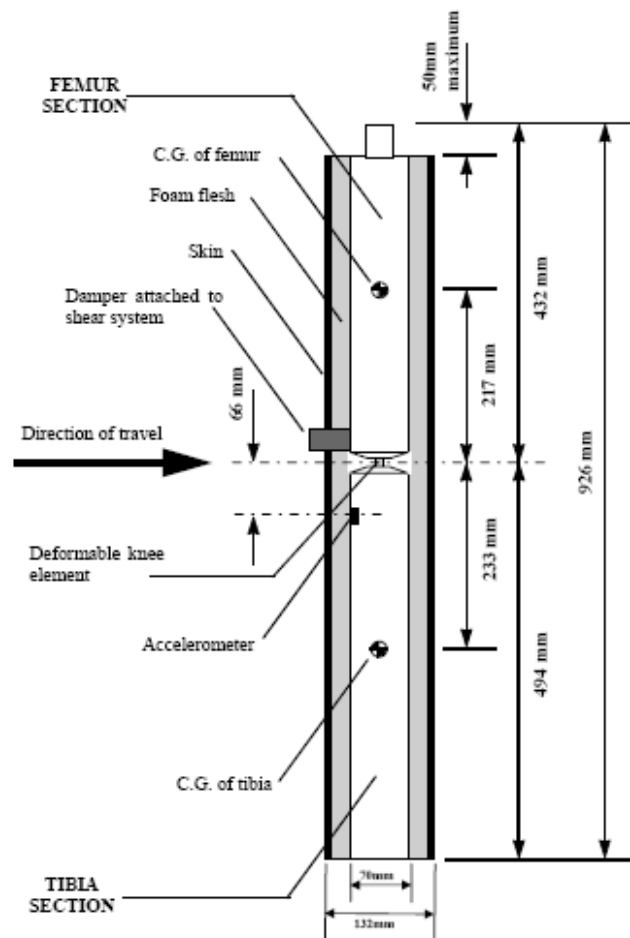

Figure 12: Lower legform impactor

3. Upper legform impactor

3.1. The upper legform impactor shall be rigid, foam covered at the impact side, and  $350 \pm 5$  mm long (see Figure 13).  
Taken from gtr, § 6.3.1.2

3.2. The total mass of the upper legform impactor including those propulsion and guidance components which are effectively part of the impactor during the impact shall be  $9.5 \text{ kg} \pm 0.1 \text{ kg}$ .  
Taken from gtr, § 6.3.1.2.1

3.3. The total mass of the front member and other components in front of the load transducer assemblies, together with those parts of the load transducer assemblies in front of the active elements, but excluding the foam and skin, shall be  $1.95 \pm 0.05 \text{ kg}$ .  
Taken from gtr, § 6.3.1.2.2

3.4. The upper legform impactor for the bumper test shall be mounted to the propulsion system by a torque limiting joint and be insensitive to off-axis loading. The impactor shall move only in the specified direction of impact when in contact with the vehicle and shall be prevented from motion in other directions including rotation about any axis.  
Taken from gtr, § 6.3.1.2.3

3.5. The torque limiting joint shall be set so that the longitudinal axis of the front member is vertical at the time of impact with a tolerance of  $\pm 2^\circ$ , with the joint friction torque set to  $675 \text{ Nm} \pm 25 \text{ Nm}$ .  
Taken from gtr, § 6.3.1.2.4

3.6. The centre of gravity of those parts of the impactor which are effectively forward of the torque limiting joint, including any weights fitted, shall lie on the longitudinal centre line of the impactor, with a tolerance of  $\pm 10 \text{ mm}$ .  
Taken from gtr, § 6.3.1.2.5

3.7. The length between the load transducer centre lines shall be  $310 \pm 1 \text{ mm}$  and the front member diameter shall be  $50 \pm 1 \text{ mm}$ .  
Taken from gtr, § 6.3.1.2.6

4. Upper legform instrumentation

4.1. The front member shall be strain gauged to measure bending moments in three positions, as shown in Figure 13, each using a separate channel. The strain gauges are located on the impactor on the back of the front member. The two outer strain gauges are located  $50 \pm 1 \text{ mm}$  from the impactor's symmetrical axis. The middle strain gauge is located on the symmetrical axis with a  $\pm 1 \text{ mm}$  tolerance.  
Taken from gtr, § 6.3.1.2.9.1

4.2. Two load transducers shall be fitted to measure individually the forces applied at either end of the upper legform impactor, plus strain gauges measuring bending moments at the centre of the upper legform impactor and at positions 50 mm either side of the centre line (see Figure 13).

Taken from gtr, § 6.3.1.2.9.2

4.3. The instrumentation response value CFC, as defined in ISO 6487:2002, shall be 180 for all transducers. The CAC response values, as defined in ISO 6487:2002, shall be 10 kN for the force transducers and 1,000 Nm for the bending moment measurements.

Taken from gtr, § 6.3.1.2.9.3

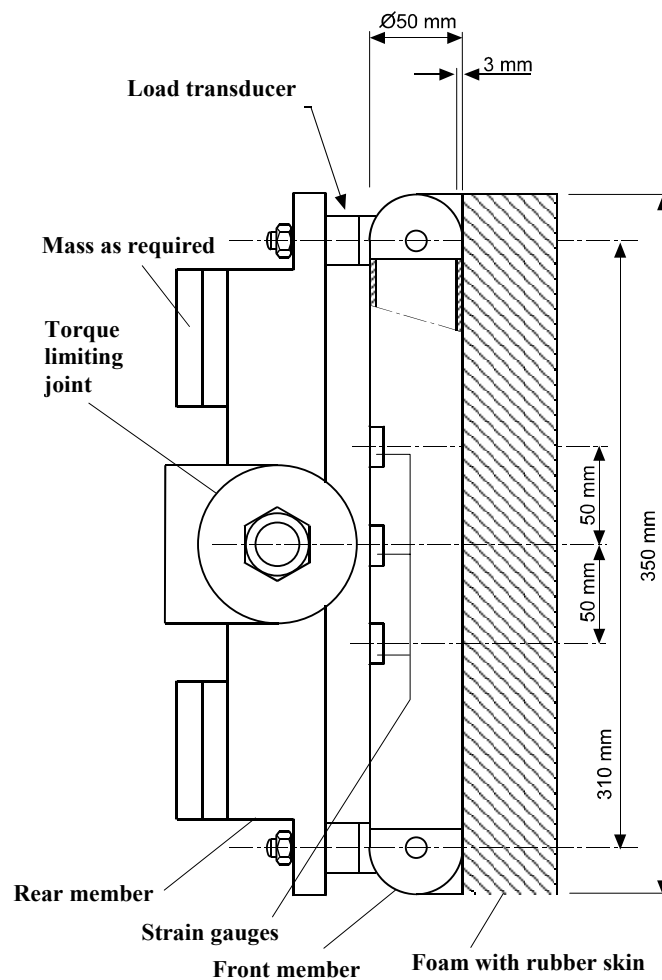

Figure 13: Upper legform impactor

5. Child and adult headform impactors

5.1. Child headform impactor (see Figure 14)

5.1.1. The child headform impactor shall be made of aluminium, be of homogenous construction and be of spherical shape. The overall diameter shall be  $165 \pm 1$  mm. The mass shall be  $3.5 \pm 0.07$  kg. The moment of inertia about an axis through the centre of gravity and perpendicular to the direction of impact shall be within the range of 0.008 to 0.012 kgm<sup>2</sup>. The centre of gravity of the headform impactor including instrumentation shall be located in the geometric centre of the sphere with a tolerance of  $\pm 2$  mm.

The sphere shall be covered with a  $14 \pm 0.5$  mm thick synthetic skin, which shall cover at least half of the sphere.

Taken from gtr, § 6.3.2.1

5.1.2. The first natural frequency of the child headform impactor shall be over 5,000 Hz.

Taken from gtr, § 6.3.2.1.2

5.2. Child headform instrumentation This whole § 5.2 taken from gtr, § 6.3.2.1.1

5.2.1. A recess in the sphere shall allow for mounting one triaxial or three uniaxial accelerometers within  $\pm 10$  mm seismic mass location tolerance from the centre of the sphere for the measurement axis, and  $\pm 1$  mm seismic mass location tolerance from the centre of the sphere for the perpendicular direction to the measurement axis.

5.2.2. If three uniaxial accelerometers are used, one of the accelerometers shall have its sensitive axis perpendicular to the mounting face A (see Figure 14) and its seismic mass shall be positioned within a cylindrical tolerance field of 1 mm radius and 20 mm length. The centre line of the tolerance field shall run perpendicular to the mounting face and its mid-point shall coincide with the centre of the sphere of the headform impactor.

5.2.3. The remaining accelerometers shall have their sensitive axes perpendicular to each other and parallel to the mounting face A and their seismic mass shall be positioned within a spherical tolerance field of 10 mm radius. The centre of the tolerance field shall coincide with the centre of the sphere of the headform impactor.

5.2.4. The instrumentation response value CFC, as defined in ISO 6487: 2002, shall be 1,000. The CAC response value, as defined in ISO 6487:2002, shall be 500g for the acceleration.

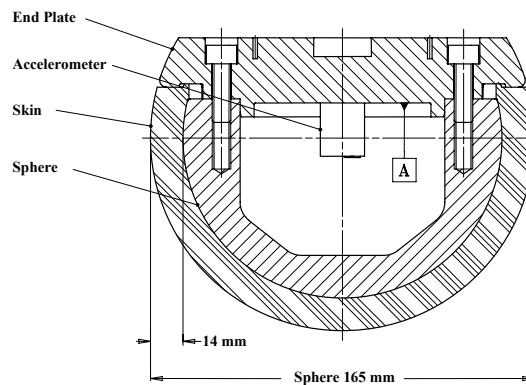

Figure 14: Child headform impactor

5.3. Adult headform impactor (see Figure 15)

5.3.1. The adult headform impactor shall be made of aluminium, be of homogenous construction and be of spherical shape. The overall diameter is  $165 \pm 1$  mm as shown in Figure 15. The mass shall be  $4.5 \pm 0.1$  kg. The moment of inertia about an axis through the centre of gravity and perpendicular to the direction of impact shall be within the range of  $0.010$  to  $0.013$   $\text{kgm}^2$ . The centre of gravity of the headform impactor including instrumentation shall be located in the geometric centre of the sphere with a tolerance of  $\pm 5$  mm.

The sphere shall be covered with a  $14 \pm 0.5$  mm thick synthetic skin, which shall cover at least half of the sphere.

Taken from gtr, § 6.3.2.2

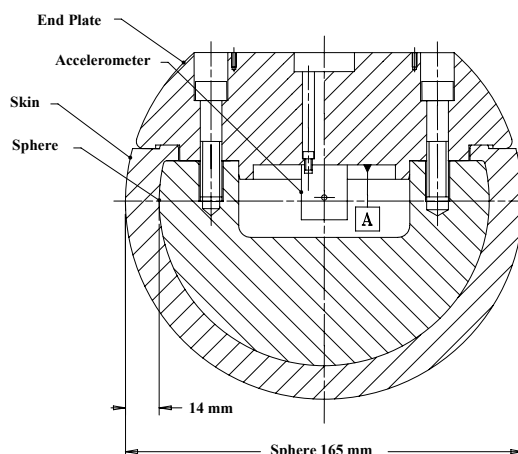

Figure 15: Adult headform impactor

5.3.2. The first natural frequency of the headform impactor shall be over 5,000 Hz. Taken from gtr, § 6.3.2.2.2

5.4. Adult headform instrumentation This whole § 5.4 taken from gtr, § 6.3.2.2.1

5.4.1. A recess in the sphere shall allow for mounting one triaxial or three uniaxial accelerometers within  $\pm 10$  mm seismic mass location tolerance from the centre of the sphere for the measurement axis, and  $\pm 1$  mm seismic mass location tolerance from the centre of the sphere for the perpendicular direction to the measurement axis.

5.4.2. If three uniaxial accelerometers are used, one of the accelerometers shall have its sensitive axis perpendicular to the mounting face A (see Figure 15) and its seismic mass shall be positioned within a cylindrical tolerance field of 1 mm radius and 20 mm length. The centre line of the tolerance field shall run perpendicular to the mounting face and its mid-point shall coincide with the centre of the sphere of the headform impactor.

5.4.3. The remaining accelerometers shall have their sensitive axes perpendicular to each other and parallel to the mounting face A and their seismic mass shall be positioned within a spherical tolerance field of 10 mm radius. The centre of the tolerance field shall coincide with the centre of the sphere of the headform impactor.

5.4.4. The instrumentation response value CFC, as defined in ISO 6487: 2002, shall be 1,000. The CAC response value, as defined in ISO 6487: 2002, shall be 500g for the acceleration.

5.5. Rear face of the child and adult headform impactors

A rear flat face shall be provided on the outer surface of the headform impactors which is perpendicular to the direction of travel, and typically perpendicular to the axis of one of the accelerometers as well as being a flat plate capable of providing for access to the accelerometers and an attachment point for the propulsion system.

Taken from gtr, § 6.3.2.3



## Annex 5

### TEST PROCEDURES

1. Lower legform to bumper
  - 1.1. For each test the impactor shall be fitted with new foam flesh cut from one of up to four consecutive sheets of foam type CF-45 flesh material or equivalent, produced from the same batch of manufacture (cut from one block or 'bun' of foam), provided that foam from one of these sheets was used in the dynamic certification test and the individual weights of these sheets are within  $\pm 2$  percent of the weight of the sheet used in the certification test.  
Taken from gtr, § 6.3.1.1.4.
  - 1.2. The test impactor or at least the foam flesh shall be stored during a period of at least four hours in a controlled storage area with a stabilized humidity of 35 percent  $\pm$  15 percent and a stabilized temperature of  $20 \pm 4^{\circ}\text{C}$  prior to impactor removal for test. After removal from the storage the impactor shall not be subjected to conditions other than those pertaining in the test area.  
Taken from gtr, § 6.3.1.1.5.
  - 1.3. Each test shall be completed within two hours of when the impactor to be used is removed from the controlled storage area.  
Taken from gtr, § 7.1.1.
  - 1.4. The selected target points shall be in the bumper test area.  
Taken from gtr, § 7.1.1.1.
  - 1.5. A minimum of three lower legform to bumper tests shall be carried out, one each to the middle and the outer thirds of the bumper at positions judged to be the most likely to cause injury. Tests shall be to different types of structure, where they vary throughout the area to be assessed. The selected test points shall be a minimum of 132 mm apart, and a minimum of 66 mm inside the defined corners of the bumper.  
These minimum distances are to be set with a flexible tape held tautly along the outer surface of the vehicle. The positions tested by the laboratories shall be indicated in the test report.  
Taken from Commission doc, Annex II, Chapter II, § 3.3.
  - 1.6. The direction of the impact velocity vector shall be in the horizontal plane and parallel to the longitudinal vertical plane of the vehicle. The tolerance for the direction of the velocity vector in the horizontal plane and in the longitudinal plane shall be  $\pm 2^{\circ}$  at the time of first contact. The axis of the impactor shall be perpendicular to the horizontal plane with a tolerance of  $\pm 2^{\circ}$  in the lateral and longitudinal plane. The horizontal, longitudinal and lateral planes are orthogonal to each other (see Figure 16).  
Taken from gtr, § 7.1.1.2.

1.7. The bottom of the impactor shall be at 25 mm above ground reference plane at the time of first contact with the bumper (see Figure 17), with a  $\pm 10$  mm tolerance. When setting the height of the propulsion system, an allowance must be made for the influence of gravity during the period of free flight of the impactor.  
 Taken from gtr, § 7.1.1.3.

1.8. The lower legform impactor for the bumper tests shall be in 'free flight' at the moment of impact. The impactor shall be released to free flight at such a distance from the vehicle that the test results are not influenced by contact of the impactor with the propulsion system during rebound of the impactor.

The impactor may be propelled by an air, spring or hydraulic gun, or by other means that can be shown to give the same result.

Taken from gtr, § 7.1.1.3.1.

1.9. At the time of first contact the impactor shall have the intended orientation about its vertical axis, for the correct operation of its knee joint, with a tolerance of  $\pm 5^\circ$  (see Figure 16).

Taken from gtr, § 7.1.1.3.2.

1.10. At the time of first contact the centre line of the impactor shall be within a  $\pm 10$  mm tolerance to the selected impact location.

Taken from gtr, § 7.1.1.3.3.

1.11. During contact between the impactor and the vehicle, the impactor shall not contact the ground or any object which is not part of the vehicle.

Taken from gtr, § 7.1.1.3.4.

1.12. The impact velocity of the impactor when striking the bumper shall be  $11.1 \pm 0.2$  m/s. The effect of gravity shall be taken into account when the impact velocity is obtained from measurements taken before the time of first contact.

Taken from gtr, § 7.1.1.4.

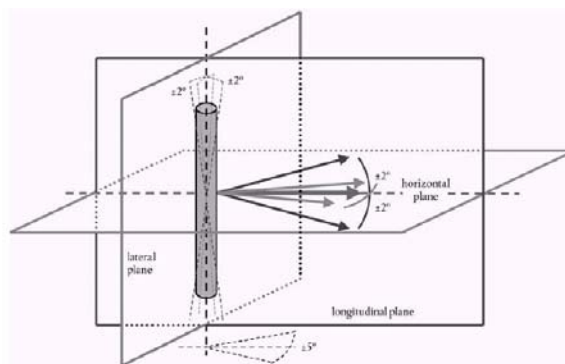

Figure 16: Tolerances of angles for the lower legform impactor at the time of the first impact

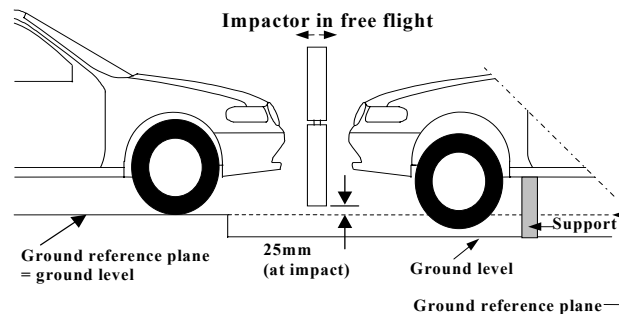

Figure 17: Lower legform to bumper tests for complete vehicle in normal ride attitude (left) and for cut-body mounted on supports (right)

## 2. Upper legform to bumper

2.1. For each test the foam flesh shall be two new sheets of 25 mm thick foam type CF-45 or equivalent, which shall be cut from the sheet of material used for the dynamic certification test. The skin shall be a 1.5 mm thick fibre reinforced rubber sheet. The mass of the foam and the rubber skin together shall be  $0.6 + 0.1$  kg (this excludes any reinforcement, mountings, etc. which are used to attach the rear edges of the rubber skin to the rear member). The foam and rubber skin shall be folded back towards the rear, with the rubber skin attached via spacers to the rear member so that the sides of the rubber skin are held parallel. The foam shall be of such a size and shape that an adequate gap is maintained between the foam and components behind the front member, to avoid significant load paths between the foam and these components.

Taken from gtr, § 6.3.1.2.7.

2.2. The test impactor or at least the foam flesh shall be stored during a period of at least four hours in a controlled storage area with a stabilized humidity of  $35 \text{ percent} \pm 15 \text{ percent}$  and a stabilized temperature of  $20 \pm 4$  °C prior to impactor removal for test. After removal from the storage the impactor shall not be subjected to conditions other than those pertaining in the test area.

Taken from gtr, § 6.3.1.2.8, but with correction

2.3. Each test shall be completed within two hours of when the impactor to be used is removed from the controlled storage area.

Taken from gtr, § 7.1.2.

2.4. The selected target points shall be in the bumper test area as defined in paragraph 2.11.

Taken from gtr, § 7.1.2.1.

2.5. A minimum of three lower legform to bumper tests shall be carried out, one each to the middle and the outer thirds of the bumper at positions judged to be the most likely to cause injury. Tests shall be to different types of structure, where they vary throughout

the area to be assessed. The selected test points shall be a minimum of 132 mm apart, and a minimum of 66 mm inside the defined corners of the bumper.

These minimum distances are to be set with a flexible tape held taut along the outer surface of the vehicle. The positions tested by the laboratories shall be indicated in the test report.

Taken from Commission doc, Annex II, Chapter III, § 3.3.

- 2.6. The direction of impact shall be parallel to the longitudinal axis of the vehicle, with the axis of the upper legform vertical at the time of first contact. The tolerance to this direction is  $\pm 2^\circ$ .

At the time of first contact the impactor centre line shall be vertically midway between the upper bumper reference line and the lower bumper reference line with a + 10 mm tolerance and the impactor vertical centre line shall be positioned laterally with the selected impact location with a tolerance of  $\pm 10$  mm.

Taken from gtr, § 7.1.2.2.

- 2.7. The impact velocity of the upper legform impactor when striking the bumper shall be  $11.1 \pm 0.2$  m/s.

Taken from gtr, § 7.1.2.3.

### 3. Child and adult headform test procedures – common test specifications

- 3.1. Propulsion of the headform impactors - Taken from gtr, § 7.2.1

- 3.1.1. The headform impactors shall be in "free flight" at the moment of impact, at the required impact velocity (as specified in paragraphs 4.6. and 5.6.) and the required direction of impact (as specified in paragraphs 4.7. and 5.7.).

- 3.1.2. The impactors shall be released to "free flight" at such a distance from the vehicle that the test results are not influenced by contact of the impactor with the propulsion system during rebound of the impactor.

- 3.2. Measurement of impact velocity - Taken from gtr, § 7.2.2

- 3.2.1. The velocity of the headform impactor shall be measured at some point during the free flight before impact, in accordance with the method specified in ISO 3784:1976. The accuracy of velocity measurement shall be  $\pm 0.01$  m/sec. The measured velocity shall be adjusted considering all factors which may affect the impactor between the point of measurement and the point of impact, in order to determine the velocity of the impactor at the time of impact. The angle of the velocity vector at the time of impact shall be calculated or measured.

3.3. Recording - Taken from gtr, § 7.2.3

3.3.1. The acceleration time histories shall be recorded, and HIC shall be calculated. The first point of contact on the front structure of the vehicle shall be recorded. Recording of test results shall be in accordance with ISO 6487:2002.

3.4. Splitting of headform test zones

3.4.1. The manufacturer shall identify the zones of the bonnet top where the HIC must not exceed 1,000 (HIC1000 zone) or 1,700 (HIC1700 zone) (see Figure 18).

Taken from gtr, § 5.2.4.1.

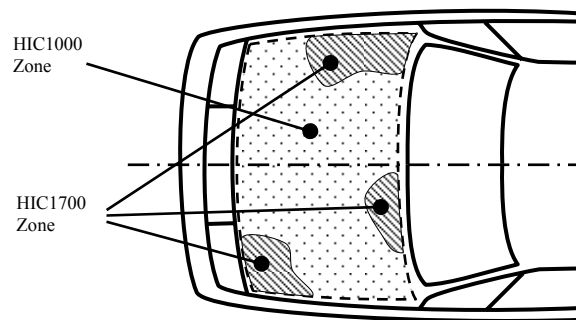

Figure 18: Example of marking of HIC1000 zone and HIC1700 zone

3.4.2. Marking of the "bonnet top" impact area as well as "HIC1000 zone" and "HIC1700 zone" will be based on a drawing supplied by the manufacturer, when viewed from a horizontal plane above the vehicle that is parallel to the vehicle horizontal zero plane. A sufficient number of x and y co-ordinates shall be supplied by the manufacturer to mark up the areas on the actual vehicle while considering the vehicle outer contour in the z direction.

Taken from gtr, § 5.2.4.2.

3.4.3. The areas of "HIC1000 zone" and "HIC1700 zone" may consist of several parts, with the number of these parts not being limited.

Taken from gtr, § 5.2.4.3.

3.4.4. The calculation of the surface of the impact area as well as the surface areas of "HIC1000 zone" and "HIC1700 zone" shall be done on the basis of a projected bonnet when viewed from a horizontal plane parallel to the horizontal zero plane above the vehicle, on the basis of the drawing data supplied by the manufacturer.

Taken from gtr, § 5.2.4.4.

3.5. Impact test points – particular specifications

Notwithstanding the provisions of paragraphs 4.2 and 5.2 below, if a number of test positions have been selected in order of potential to cause injury and the test area remaining is too small to select another test position while maintaining the minimum spacing between tests, then less than nine tests for each impactor may be performed. The positions tested by the laboratories shall be indicated in the test report. However, the technical services conducting the tests shall perform as many tests as necessary to guarantee the compliance of the vehicle with the head injury criteria (HIC) limit values of 1000 for the HIC1000 zone and 1700 for the HIC1700 zone, especially in the points near to the borders between the two types of zones."

Based on Commission document, chapter V, § 3.2 and chapter VI, § 3.2

#### 4. Child headform - specific test procedure

4.1. Tests shall be made to the front structure within the boundaries as defined in paragraph 2.13. For tests on the rear area of the bonnet top, the headform impactor shall not contact the windscreen or A-pillar before impacting the bonnet top.

Taken from gtr, § 7.3.1.

4.2. A minimum of nine tests shall be carried out with the child headform impactor, three tests each to the middle and the outer thirds of the child/small adult bonnet top test areas, at positions judged to be the most likely to cause injury.

Tests shall be to different types of structure, where these vary throughout the area to be assessed and at positions judged to be the most likely to cause injury.

Based on Commission doc, Annex 22, Chapter VII, § 3.1.1.

4.3. The selected test points for the child/small adult headform impactor shall be at the time of first contact:

- (a) a minimum of 165 mm apart, and
- (b) a minimum of 82.5 mm inside the defined side reference lines, and;
- (c) forward of the WAD1700 line or a minimum of 82.5 mm forward of the bonnet rear reference line, whichever is most forward at the point of measurement, and
- (d) rearward of the WAD1000 line, or a minimum of 82.5 mm rearwards of the bonnet leading edge reference line, whichever is most rearward at the point of measurement.

These minimum distances are to be set with a flexible tape held tautly along the outer surface of the vehicle.

Based on a combination of gtr, § 7.3.2 and on Commission doc, Annex 22, Chapter VII, § 3.2.

4.4. No impact point shall be located so that the impactor will impact the test area with a glancing blow resulting in a more severe second impact outside the test area.

Taken from gtr, § 7.3.2. – first part

4.5. The point of first contact of the headform impactor shall be within a  $\pm 10$  mm tolerance to the selected impact point.

Taken from gtr, § 7.3.3

4.6. The headform velocity at the time of impact shall be  $9.7 \pm 0.2$  m/s.

Taken from gtr, § 7.3.4.

4.7. The direction of impact shall be in the longitudinal vertical plane of the vehicle to be tested at an angle of  $50 \pm 2^\circ$  to the horizontal. The direction of impact of tests to the front structure shall be downward and rearward.

Taken from gtr, § 7.3.5.

## 5. Adult headform specific test procedure

5.1. Tests shall be made to the front structure within the boundaries as defined in paragraph 2.1. For tests at the rear of the bonnet top, the headform impactor shall not contact the windscreen or A-pillar before impacting the bonnet top.

Taken from gtr, § 7.4.1.

5.2. A minimum of nine tests shall be carried out with the adult headform impactor, three tests each to the middle and the outer thirds of the adult bonnet top test areas, at positions judged to be the most likely to cause injury.

Tests shall be to different types of structure, where these vary throughout the area to be assessed and at positions judged to be the most likely to cause injury.

Based on Commission doc, Annex 22, Chapter VII, § 3.1.1.

5.3. Selected impact points on the bonnet for the adult headform impactor shall be, at the time of first contact:

- (a) a minimum of 165 mm apart, and
- (b) a minimum of 82.5 mm inside the defined side reference lines, and;
- (c) forward of the WAD2100 line or a minimum of 82.5 mm forward of the bonnet rear reference line, whichever is most forward at the point of measurement, and;
- (d) rearward of the WAD1700 line or a minimum of 82.5 mm rearward of the bonnet leading edge reference line, whichever is most rearward at the point of measurement

These minimum distances are to be set with a flexible tape held tautly along the outer surface of the vehicle.

Based on a combination of gtr, § 7.4.2 and on Commission doc, Annex 22, Chapter VII, § 3.3.

5.4. No impact point shall be located so that the impactor will impact the test area with a glancing blow resulting in a more severe second impact outside the test area.

Taken from gtr, § 7.4.2.- first part

5.5. The point of first contact of the headform impactor shall be within a  $\pm 10$  mm tolerance to the selected impact point.

Taken from gtr, § 7.4.3.

5.6. The headform velocity at the time of impact shall be  $9.7 \pm 0.2$  m/s.

Taken from gtr, § 7.4.4.

5.7. The direction of impact shall be in the longitudinal vertical plane of the paragraph of the vehicle to be tested at an angle of  $65^\circ \pm 2^\circ$  to the horizontal. The direction of impact of tests to the front structure shall be downward and rearward.

Taken from gtr, § 7.4.5.



## Annex 6

### CERTIFICATION OF THE IMPACTORS

#### 1. Lower legform impactor certification

- 1.1. The certified impactor may be used for a maximum of 20 impacts before re-certification. With each test new plastically deformable knee elements shall be used. The impactor shall also be re-certified if more than one year has elapsed since the previous certification, if any impactor transducer output, in any impact, has exceeded the specified CAC or has reached the mechanical limits of the leg impactor deformation capability.

Taken from gtr, § 6.3.1.1.7.2, with replacement of "should" by "shall"

#### 1.2. Static tests

- 1.2.1. For both tests specified in § 1.2.2 and 1.2.3 below, the impactor shall have the intended orientation about its longitudinal axis, for the correct operation of its knee joint, with a tolerance of  $\pm 2^\circ$ .

The stabilized temperature of the impactor during certification shall be  $20^\circ \pm 2^\circ\text{C}$ .

The CAC response values, as defined in ISO 6487:2002 shall be  $50^\circ$  for the knee bending angle and 500 N for the applied force when the impactor is loaded in bending in accordance with paragraph 1.2.4., and 10 mm for the shearing displacement and 10 kN for the applied force when the impactor is loaded in shearing in accordance with paragraph 1.2.5. For both tests low-pass filtering at an appropriate frequency is permitted, to remove higher frequency noise without significantly affecting the measurement of the response of the impactor.

Based on gtr, § 8.1.1.1

- 1.2.2. When the impactor is loaded in bending in accordance with paragraph 1.2.4. below, the applied force/bending angle response shall be within the limits shown in Figure 19. Also, the energy taken to generate  $15.0^\circ$  of bending shall be  $100 \pm 7$  J.

Based on gtr, § 8.1.1.2.

- 1.2.3. When the impactor is loaded in shearing in accordance with paragraph 1.2.5. below, the applied force/shearing displacement response shall be within the limits shown in Figure 20.

Based on gtr, § 8.1.1.3.

- 1.2.4. The impactor, without foam covering and skin, shall be mounted with the tibia firmly clamped to a fixed horizontal surface and a metal tube connected firmly to the femur, as shown in Figure 21. The rotational axis of the impactor knee joint shall be vertical. To

avoid friction errors, no support shall be provided to the femur section or the metal tube. The bending moment applied at the centre of the knee joint, due to the mass of the metal tube and other components (excluding the legform itself), shall not exceed 25 Nm.

A horizontal normal force shall be applied to the metal tube at a distance of  $2.0 \pm 0.01$  m from the centre of the knee joint and the resulting angle of knee deflection shall be recorded. The load shall be increased at a rate between 1.0 and  $10^\circ/\text{s}$  until the angle of deflection of the knee is in excess of  $22^\circ$ . Brief excursions from these limits due, for instance, to the use of a hand-pump shall be permitted.

The energy is calculated by integrating the force with respect to the bending angle in radians, and multiplying by the lever length of  $2.0 \pm 0.01$  m.

Taken from gtr, § 8.1.1.4.

- 1.2.5. The impactor, without foam covering and skin, shall be mounted with the tibia firmly clamped to a fixed horizontal surface and a metal tube connected firmly to the femur and restrained at 2.0 m from the centre of the knee joint, as shown in Figure 22.

A horizontal normal force shall be applied to the femur at a distance of 50 mm from the centre of the knee joint and the resulting knee shearing displacement shall be recorded. The load shall be increased **at a rate** between 0.1 and 20 mm/s until the shearing displacement of the knee is in excess of 7.0 mm or the load is in excess of 6.0 kN. Brief excursions from these limits due, for instance, to the use of a hand-pump shall be permitted.

Taken from gtr, § 8.1.1.5., with minor modifications

### 1.3. Dynamic tests

#### 1.3.1. Calibration

- 1.3.1.1. The foam flesh for the test impactor shall be stored for a period of at least four hours in a controlled storage area with a stabilized humidity of  $35 \pm 10$  percent and a stabilized temperature of  $20 \pm 2^\circ\text{C}$  prior to impactor removal for calibration. The test impactor itself shall have a temperature of  $20^\circ \pm 2^\circ\text{C}$  at the time of impact. The temperature tolerances for the test impactor shall apply at a relative humidity of  $40 \pm 30$  percent after a soak period of at least four hours prior to their application in a test.

Taken from gtr, § 8.1.2.2.1.

- 1.3.1.2. The test facility used for the calibration test shall have a stabilized humidity of  $40 \pm 30$  percent and a stabilized temperature of  $20 \pm 4^\circ\text{C}$  during calibration.

Taken from gtr, § 8.1.2.2.2.

- 1.3.1.3. Each calibration shall be completed within two hours of when the impactor to be calibrated is removed from the controlled storage area.

Taken from gtr, § 8.1.2.2.3.

- 1.3.1.4. The relative humidity and temperature of the calibration area shall be measured at the time of calibration and recorded in the calibration report.

Taken from gtr, § 8.1.2.2.4.

### 1.3.2. Requirements

- 1.3.2.1. When the impactor is impacted by a linearly guided certification impactor, as specified in paragraph 1.3.3., the maximum upper tibia acceleration shall be not less than 120g and not more than 250g. The maximum bending angle shall be not less than 6.2° and not more than 8.2°. The maximum shearing displacement shall be not less than 3.5 mm and not more than 6.0 mm.

For all these values, the readings used shall be from the initial impact with the certification impactor and not from the arresting phase. Any system used to arrest the impactor or certification impactor shall be so arranged that the arresting phase does not overlap in time with the initial impact. The arresting system shall not cause the transducer outputs to exceed the specified CAC.

Taken from gtr, § 8.1.2.3.1.

- 1.3.2.2. The instrumentation response value CFC, as defined in ISO 6487:2002, shall be 180 for all transducers. The CAC response values, as defined in ISO 6487:2002, shall be 50° for the knee bending angle, 10 mm for the shearing displacement and 500g for the acceleration. This does not require that the impactor itself be able to physically bend and shear to these angles and displacements.

Taken from gtr, § 8.1.2.3.2.

### 1.3.3. Test procedure

- 1.3.3.1. The impactor, including foam covering and skin, shall be suspended horizontally by three wire ropes of  $1.5 \pm 0.2$  mm diameter and of 2000 mm minimum length, as shown in Figure 23. It shall be suspended with its longitudinal axis horizontal, with a tolerance of  $\pm 0.5^\circ$ , and perpendicular to the direction of the certification impactor motion, with a tolerance of  $\pm 2^\circ$ . The impactor shall have the intended orientation about its longitudinal axis, for the correct operation of its knee joint, with a tolerance of  $\pm 2^\circ$ . The impactor must meet the requirements of paragraph 1.1., with the attachment bracket(s) for the wire ropes fitted.

Taken from gtr, § 8.1.2.4.1.

- 1.3.3.2. The certification impactor shall have a mass of  $9.0 \pm 0.05$  kg, this mass includes those propulsion and guidance components which are effectively part of the impactor during impact. The dimensions of the face of the certification impactor shall be as specified in Figure 24. The face of the certification impactor shall be made of aluminium, with an outer surface finish of better than 2.0 micrometers.

The guidance system shall be fitted with low friction guides, insensitive to off-axis loading, that allow the impactor to move only in the specified direction of impact, when in contact with the vehicle. The guides shall prevent motion in other directions including rotation about any axis.

Taken from gtr, § 8.1.2.4.2.

1.3.3.3. The impactor shall be certified with previously unused foam.

Taken from gtr, § 8.1.2.4.3.

1.3.3.4. The impactor foam shall not be excessively handled or deformed before, during or after fitting.

Taken from gtr, § 8.1.2.4.4.

1.3.3.5. The certification impactor shall be propelled horizontally at a velocity of  $7.5 \pm 0.1$  m/s into the stationary impactor as shown in Figure 24. The certification impactor shall be positioned so that its centreline aligns with a position on the tibia centreline of 50 mm from the centre of the knee, with tolerances of  $\pm 3$  mm laterally and  $\pm 3$  mm vertically.

Taken from gtr, § 8.1.2.4.5.

## 2. Upper legform impactor certification

2.1. The certified impactor may be used for a maximum of 20 impacts before re-certification (this limit does not apply to propulsion or guidance components). The impactor shall also be re-certified if more than one year has elapsed since the previous certification or if any impactor transducer output, in any impact, has exceeded the specified CAC.

Taken from gtr, § 6.3.1.2.10.2.

### 2.2. Calibration

2.2.1. The foam flesh for the test impactor shall be stored for a period of at least four hours in a controlled storage area with a stabilized humidity of  $35 \pm 10$  percent and a stabilized temperature of  $20^\circ \pm 2^\circ\text{C}$  prior to impactor removal for calibration. The test impactor itself shall have a temperature of  $20^\circ \pm 2^\circ\text{C}$  at the time of impact. The temperature tolerances for the test impactor shall apply at a relative humidity of  $40 \pm 30$  percent after a soak period of at least four hours prior to their application in a test.

Taken from gtr, § 8.2.2.1.

2.2.2. The test facility used for the calibration test shall have a stabilized humidity of  $40 \pm 30$  percent and a stabilized temperature of  $20^\circ \pm 4^\circ\text{C}$  during calibration.

Taken from gtr, § 8.2.2.2.

2.2.3. Each calibration shall be completed within two hours of when the impactor to be calibrated is removed from the controlled storage area.

Taken from gtr, § 8.2.2.3.

2.2.4. The relative humidity and temperature of the calibration area shall be measured at the time of calibration, and recorded in the calibration report.

Taken from gtr, § 8.2.2.4.

## 2.3. Requirements

2.3.1. When the impactor is propelled into a stationary cylindrical pendulum the peak force measured in each load transducer shall be not less than 1.20 kN and not more than 1.55 kN and the difference between the peak forces measured in the top and bottom load transducers shall not be more than 0.10 kN. Also, the peak bending moment measured by the strain gauges shall not be less than 190 Nm and not more than 250 Nm on the centre position and not less than 160 Nm and not more than 220 Nm for the outer positions. The difference between the upper and lower peak bending moments shall not be more than 20 Nm.

For all these values, the readings used shall be from the initial impact with the pendulum and not from the arresting phase. Any system used to arrest the impactor or pendulum shall be so arranged that the arresting phase does not overlap in time with the initial impact. The arresting system shall not cause the transducer outputs to exceed the specified CAC.

Taken from gtr, § 8.2.3.1.

2.3.2. The instrumentation response value CFC, as defined in ISO 6487:2002, shall be 180 for all transducers. The CAC response values, as defined in ISO 6487:2002, shall be 10 kN for the force transducers and 1000 Nm for the bending moment measurements.

8.2.3.2.

## 2.4. Test procedure

2.4.1. The impactor shall be mounted to the propulsion and guidance system, by a torque limiting joint. The torque limiting joint shall be set so that the longitudinal axis of the front member is perpendicular to the axis of the guidance system, with a tolerance of  $\pm 2^\circ$ , with the joint friction torque set to  $675 \pm 25$  Nm. The guidance system shall be fitted with low friction guides that allow the impactor to move only in the specified direction of impact, when in contact with the pendulum.

Taken from gtr, § 8.2.4.1.

2.4.2. The impactor mass shall be adjusted to give a mass of  $12 \pm 0.1$  kg, this mass includes those propulsion and guidance components which are effectively part of the impactor during impact.

Taken from gtr, § 8.2.4.2.

2.4.3. The centre of gravity of those parts of the impactor which are effectively forward of the torque limiting joint, including the extra masses fitted, shall lie on the longitudinal centreline of the impactor, with a tolerance of  $\pm 10$  mm.

Taken from gtr, § 8.2.4.3.

2.4.4. The impactor shall be certified with previously unused foam.

Taken from gtr, § 8.2.4.4.

2.4.5. The impactor foam shall not be excessively handled or deformed before, during or after fitting.

**Erreur ! Liaison incorrecte.8.2.4.5.**

2.4.6. The impactor with the front member vertical shall be propelled horizontally at a velocity of  $7.1 \pm 0.1$  m/s into the stationary pendulum as shown in Figure 25.

**Erreur ! Liaison incorrecte.8.2.4.6.**

2.4.7. The pendulum tube shall have a mass of  $3 \pm 0.03$  kg, a wall thickness of  $3 \pm 0.15$  mm and an outside diameter of  $150 \text{ mm} +1 \text{ mm}/-4 \text{ mm}$ . Total pendulum tube length shall be  $275 \pm 25$  mm. The pendulum tube shall be made from cold finished seamless steel (metal surface plating is permissible for protection from corrosion), with an outer surface finish of better than 2.0 micrometer. It shall be suspended on two wire ropes of  $1.5 \pm 0.2$  mm diameter and of 2.0 m minimum length. The surface of the pendulum shall be clean and dry. The pendulum tube shall be positioned so that the longitudinal axis of the cylinder is perpendicular to the front member (i.e. level), with a tolerance of  $\pm 2^\circ$ , and to the direction of impactor motion, with a tolerance of  $\pm 2^\circ$ , and with the centre of the pendulum tube aligned with the centre of the impactor front member, with tolerances of  $\pm 5$  mm laterally and  $\pm 5$  mm vertically.

**Erreur ! Liaison incorrecte.8.2.4.7.**

### 3. Child and adult headform

3.1. The certified impactors may be used for a maximum of 20 impacts before re-certification. The impactors shall be re-certified if more than one year has elapsed since the previous certification or if the transducer output, in any impact, has exceeded the specified CAC.

**Erreur ! Liaison incorrecte.6.3.2.4.**

#### 3.2. Drop test

3.2.1. When the headform impactors are dropped from a height of  $376 \pm 1$  mm in accordance with paragraph 3.3 below, the peak resultant acceleration measured by one triaxial (or three uniaxial) accelerometer (accelerometers) in the headform impactor shall be:

- a) for the child headform impactor not less than 245g and not more than 300g;
- b) for the adult headform impactor not less than 225g and not more than 275g.

The acceleration time curve shall be uni-modal.

**Erreur ! Liaison incorrecte.8.3.2.1.**

3.2.2. The instrumentation response values CFC and CAC for each accelerometer shall be 1,000 Hz and 500g respectively as defined in ISO 6487:2002.

**Erreur ! Liaison incorrecte.8.3.2.2.**

3.2.3. The headform impactors shall have a temperature of  $20 \pm 2^{\circ}\text{C}$  at the time of impact. The temperature tolerances shall apply at a relative humidity of  $40 \pm 30$  percent after a soak period of at least four hours prior to their application in a test.

**Erreur ! Liaison incorrecte.8.3.2.3.**

3.3. Test procedure

3.3.1. The headform impactor shall be suspended from a drop rig as shown in Figure 26.

**Erreur ! Liaison incorrecte.8.3.3.1.**

3.3.2. The headform impactor shall be dropped from the specified height by means that ensure instant release onto a rigidly supported flat horizontal steel plate, over 50 mm thick and over 300 x 300 mm square which has a clean dry surface and a surface finish of between 0.2 and 2.0 micrometers.

**Erreur ! Liaison incorrecte.8.3.3.2.**

3.3.3. The headform impactor shall be dropped with the rear face of the impactor at the test angle specified in Annex 5, paragraph 4.7 for the child headform impactor and in Annex 5, paragraph 5.7 for the adult headform impactor with respect to the vertical as shown in Figure 25. The suspension of the headform impactor shall be such that it does not rotate during the fall.

**Erreur ! Liaison incorrecte.8.3.3.3.**

3.3.4. The drop test shall be performed three times, with the headform impactor rotated  $120^{\circ}$  around its symmetrical axis after each test.

**Erreur ! Liaison incorrecte.8.3.3.4.**

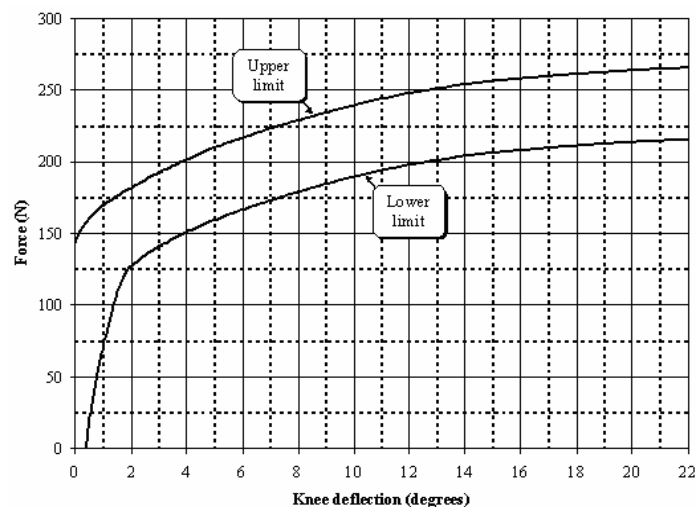

Figure 19: Force versus angle requirement in static lower legform impactor bending certification test

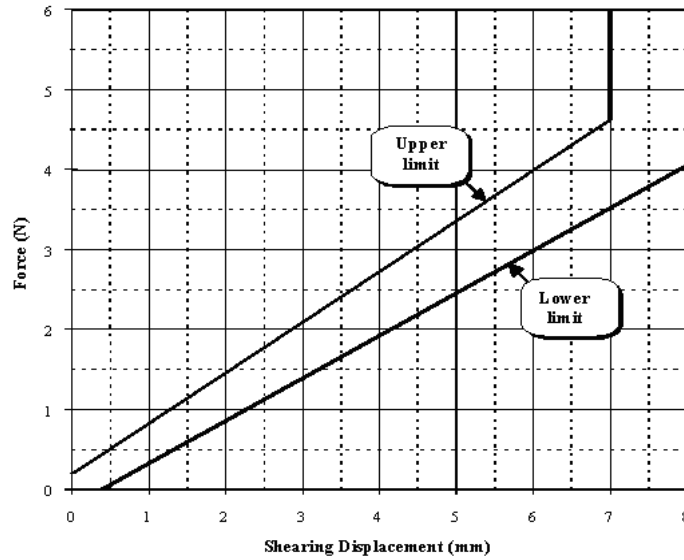

Figure 20: Force versus displacement requirement in static lower legform impactor shearing certification test

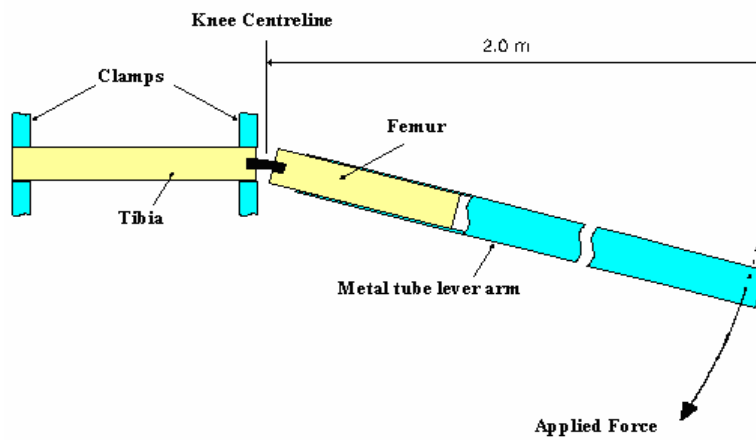

Figure 21: Top view of test set-up for static lower legform impactor bending certification test



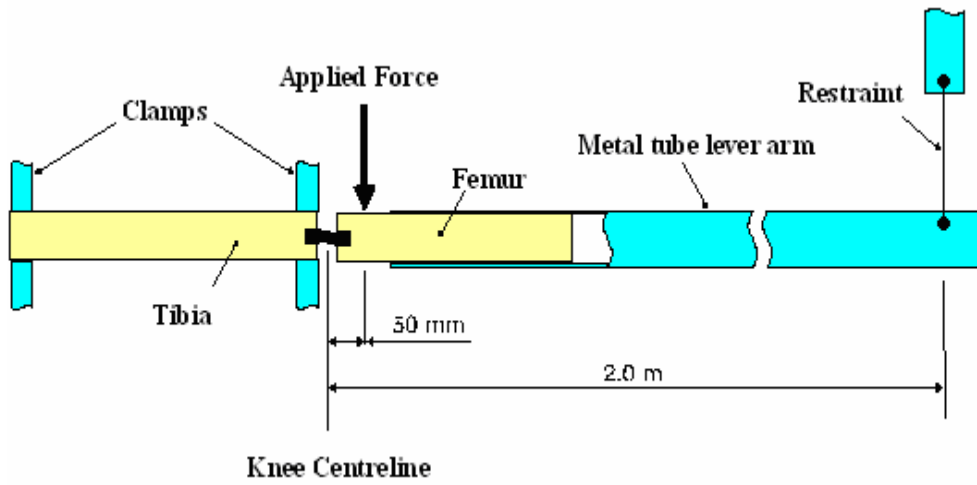

Figure 22: Top view of test set-up for static lower legform impactor shearing certification test

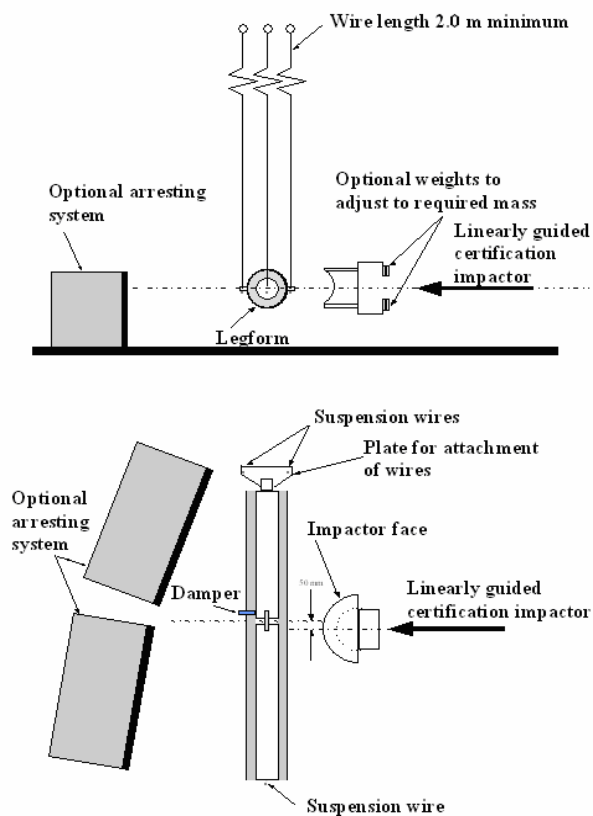

Figure 23: Test set-up for dynamic lower legform impactor certification test (side view top diagram, view from above bottom diagram)

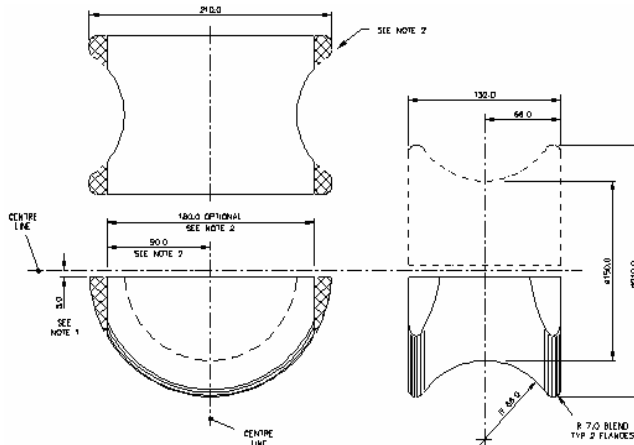

Figure 24: Details of dynamic lower legform certification impactor face

Notes:

1. Saddle may be made as a complete diameter and cut as shown to make two components.
  2. The shaded areas may be removed to give the alternative form shown.
  3. Tolerance on all dimensions is  $\pm 1.0$  mm.
- Material: Aluminium alloy.

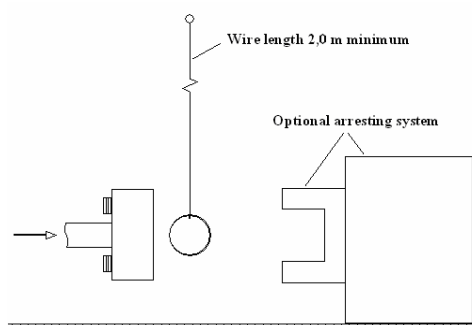

Figure 25. Test set-up for dynamic upper legform impactor certification test

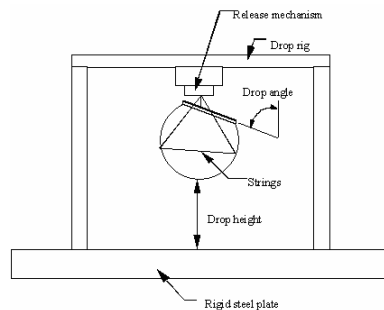

Figure 26. Test set-up for dynamic headform impactor biofidelity test

-----