

Proposal for draft amendments to Regulation No. 41
(Motorcycle noise emissions)

NOTES:

- In black colour, the original text from R41_rev1 consolidated with its amendments #1 and #2

- In red colour, the text imported from ISO-DIS 362-2.2 (second ballot)

- In green colour, the text imported from draft revised R-51

- In blue colour, the text needed to merge the documents

- In purple colour, the draft text for cycle beating provisions

- Highlighted in yellow, the text to be further checked

Regulation No. 41

UNIFORM PROVISIONS CONCERNING THE APPROVAL OF MOTOR CYCLES
WITH REGARD TO NOISE

CONTENTS

	<u>Page</u>
1. SCOPE	3
2. DEFINITIONS, TERMS AND SYMBOLS	3
3. APPLICATION FOR APPROVAL	7
4. MARKINGS	7
5. APPROVAL	7
6. SPECIFICATIONS	10
7. MODIFICATION AND EXTENSION OF THE APPROVAL OF THE MOTORCYCLE TYPE OR OF THE TYPE OF EXHAUST OR SILENCING SYSTEM(S).	11
8. CONFORMITY OF PRODUCTION	12
9. PENALTIES FOR NON-CONFORMITY OF PRODUCTION	12
10. PRODUCTION DEFINITELY DISCONTINUED	13
11. NAMES AND ADDRESSES OF TECHNICAL SERVICES RESPONSIBLE FOR CONDUCTING APPROVAL TESTS, AND OF ADMINISTRATIVE DEPARTMENTS	13
12. TRANSITIONAL PROVISIONS	13

ANNEXES

Annex 1 - Communication concerning the approval or extension or refusal or withdrawal of approval of production definitely discontinued of a motor cycle type with regard to noise emitted by motor cycles pursuant to Regulation No. 41

Annex 2 - Arrangements of approval marks

Annex 3 - Methods and instruments for measuring the noise made by motor cycles

GE.94-21808

Annex 4 - Test track specifications

Annex 5 - Exhaust system (silencer)

Annex 6 - Maximum limits of sound level (new motor cycles)

Annex 7 - Additional sound emission provisions (new motor cycles and new exhaust or silencing systems)

Regulation No. 41

UNIFORM PROVISIONS CONCERNING THE APPROVAL OF MOTOR CYCLES
WITH REGARD TO NOISE

1. SCOPE

This Regulation applies to vehicles of category L3^{*/} with regard to noise.

2. DEFINITIONS, TERMS AND SYMBOLS

For the purpose of this Regulation

2.1. "Approval of a motor cycle" means the approval of a motor cycle type with regard to noise;

2.2. "type of motorcycle as regards its sound level and exhaust system" means motorcycles which do not differ in such essential respects as the following:

2.2.1. the type of engine (two-stroke or four-stroke, reciprocating piston engine or rotary-piston engine, number and capacity of cylinders, number and type of carburettors or injection systems, arrangement of valves, net maximum power and corresponding speed). For rotary-piston engines the cubic capacity should be taken to be double of the volume of the chamber;

2.2.2. transmission system, in particular the number and ratios of the gears;

2.2.3. number, type and arrangement of exhaust systems.

2.3. "Exhaust or silencing system" means a complete set of components necessary to limit the noise caused by a motorcycle engine and its exhaust.

2.3.1. "Original exhaust or silencing system" means a system of a type fitted to the vehicle at the time of type-approval or extension of type-approval. It may be original or a replacement.

2.3.2. "Non-original exhaust or silencing system" means a system of a type other than that fitted to the vehicle at the time of type-approval or extension of type-approval. It may be used only as a replacement exhaust or silencing system.

^{*}/ As defined in the Consolidated Resolution on the Construction of Vehicles (R.E.3), Annex 7 (documents TRANS/WP.29/78/Rev.1/Amend.2 and Amend.4).

- 2.4. "Exhaust or silencing systems of differing types" means systems which are fundamentally different in one of the following ways:
- 2.4.1. systems comprising components bearing different factory or trade marks;
- 2.4.2. systems comprising any component made of materials of different characteristics or comprising components which are of a different shape or size;
- 2.4.3. systems in which the operating principles of at least one component are different;
- 2.4.4. systems comprising components in different combinations.
- 2.5. "Component of an exhaust system" means one of the individual components which together form the exhaust system (such as exhaust pipework, the silencer proper) and the intake system (air filter) if any.

If the engine has to be equipped with an intake system (air filter and/or intake noise absorber) in order to comply with the maximum permissible sound levels, the filter and/or absorber must be treated as components having the same importance as the exhaust system.

- 2.6. For the purpose of this Regulation, the following terms and definitions apply:
- 2.6.1. kerb mass
complete shipping mass of a vehicle fitted with all equipment necessary for normal operation plus the mass of the following elements:
- lubricants, coolant (if needed), washer fluid,
 - fuel (tank filled to at least 90 % of the capacity specified by the manufacturer),
 - other equipment if included as basic parts for the vehicle such as spare wheel(s), wheel chocks, fire extinguisher(s), spare parts, and tool-kit.
- NOTE: The definition of kerb mass may vary from country to country, but in this **regulation** it refers to the definition contained in ISO 6726:1988.
- 2.6.2. test mass
mass m_t , in kg, specified as:
 $m_t = m_{ref} = m_{kerb} + m_d = m_{kerb} + 75 \text{ kg} \pm 5 \text{ kg}$ (75 kg \pm 5 kg equates to mass of the driver m_d)
- 2.6.3. driver mass
nominal mass of a driver

2.6.4 power-to-mass ratio index
PMR
dimensionless quantity used for the calculation of acceleration according to the equation:

$$\text{PMR} = \frac{P_n}{m_t} \times 1000 \quad (1)$$

where

P_n is the numerical value of the rated engine power as defined in ISO 4106:2004, expressed in kilowatts;

m_t is the numerical value of the test mass, expressed in kilograms.

2.6.5 rated engine speed
S
engine speed at which the engine develops its rated maximum net power as stated by the manufacturer

NOTE 1 If the rated maximum net power is reached at several engine speeds, S is used in this **regulation** as the highest engine speed at which the rated maximum net power is reached.

~~NOTE 2 ISO 80000-3 defines this term as "rated engine rotational frequency". The term "rated engine speed" was retained due to its common understanding by practitioners and its use in government regulations.~~

2.6.6 reference point
the front end of the vehicle

2.6.7 target acceleration
acceleration at a partial throttle condition in urban traffic, derived from statistical investigations

~~NOTE Refer to Annex A for more detailed explanations.~~

2.6.8 reference acceleration
required acceleration for the acceleration test on the test track

~~NOTE Refer to Annex A for more detailed explanations.~~

2.6.9 gear ratio weighting factor
k
dimensionless quantity used to combine the test results of two gear ratios for the acceleration test and the constant-speed test

2.6.10 partial power factor
kP
dimensionless quantity used for the weighted combination of the test results of the acceleration test and the constant-speed test

~~NOTE Refer to Annex A for more detailed explanations.~~

2.6.11 pre-acceleration
application of acceleration control device prior to the position AA' for the purpose of achieving stable acceleration between AA' and BB'

NOTE See Figure 1 to Annex 4 for additional details.

- 2.6.12 locked gear ratio
control of transmission such that the transmission gear cannot change during a test
- 2.6.13 engine
power source without detachable accessories
- 2.6.14 test track length
 l_{10}
length of test track used in the calculation of acceleration from points PP' to BB'
- 2.6.15 test track length
 l_{20}
length of test track used in the calculation of acceleration from points AA' to BB'
- 2.7. Symbols and abbreviated terms

Symbol	Unit	Explanation
AA'	-	line perpendicular to vehicle travel which indicates beginning of zone to record sound pressure level during test
$a_{\text{wot } 50}$	m/s ²	wide-open-throttle acceleration at 95 th percentile of engine speed ratio and applicable test speed
$a_{\text{wot } i}$	m/s ²	acceleration at wide open throttle in gear i
$a_{\text{wot } (i+1)}$	m/s ²	acceleration at wide-open throttle in gear $i+1$
$a_{\text{wot test}}$	m/s ²	acceleration at wide-open throttle in single gear test cases
$a_{\text{wot ref}}$	m/s ²	reference acceleration for the wide-open-throttle test
a_{urban}	m/s ²	target acceleration representing urban traffic acceleration
BB'	-	line perpendicular to vehicle travel which indicates end of zone to record sound pressure level during test
CC'	-	line of vehicle travel through test surface defined in ISO 10844:1994
$\delta_1 - \delta_7$	dB	input quantities to allow for any uncertainty
gear i	-	first of two gear ratios for use in the vehicle test
gear $(i+1)$	-	second of two gear ratios, with an engine speed lower than gear ratio i
j	-	index for single test run within overall acceleration or constant speed test series i or $(i+1)$
k_p	-	partial power factor
k	-	gear ratio weighting factor
k_n	-	interpolation factor between gears
l_{ref}	m	reference length
l_{veh}	m	length of vehicle
l_{10}	m	length of test track section from PP' to BB' for calculation of acceleration from PP' to BB'.
l_{20}	m	length of test track section from AA' to BB' for calculation of acceleration from AA' to BB'.

$L_{crs\ i}$	dB	vehicle sound pressure level at constant speed test for gear i
$L_{crs(i+1)}$	dB	vehicle sound pressure level at constant speed test for gear $(i+1)$
$L_{crs\ rep}$	dB	reported vehicle sound pressure level at constant speed test
$L_{wot\ i}$	dB	vehicle sound pressure level at wide-open-throttle test for gear $(i+1)$
$L_{wot\ (i+1)}$	dB	vehicle sound pressure level at wide-open-throttle test for gear $(i+1)$
$L_{wot\ rep}$	dB	reported vehicle sound pressure level at wide-open throttle
L_{urban}	dB	reported vehicle sound pressure level representing urban operation
m_d	kg	mass of driver
m_{kerb}	kg	kerb mass of the vehicle
m_{ref}	kg	kerb mass + 75 kg \pm 5 kg for the driver
m_t	kg	test mass of the vehicle
n	1/min	engine speed of the vehicle
$n_{PP'}$	1/min	engine speed of the vehicle when the front of the vehicle passes PP'
$n_{BB'}$	1/min	engine speed of the vehicle when the front of the vehicle passes BB'
$(n/S)_{95}$	-	95th percentile dimensionless engine speed ratio
PMR	-	power-to-mass ratio index to be used for calculations
P_n	kW	rated engine power
PP'	-	line perpendicular to vehicle travel which indicates location of microphones
S	1/min	rated engine speed in revs per minute, synonymous with the engine speed at maximum power
$v_{AA'}$	km/h	vehicle speed when front of the vehicle passes line AA'
$v_{BB'}$	km/h	vehicle speed when rear of vehicle passes line BB'
v_{max}	km/h	maximum vehicle speed as defined in ISO 7117:1995
$v_{PP'}$	km/h	vehicle speed when front of the vehicle passes line PP'
v_{test}	km/h	target vehicle test speed

Table 1 – Symbols used and corresponding clauses

3. APPLICATION FOR APPROVAL

3.1. The application for approval of a motor cycle type with regard to noise made by motor cycles shall be submitted by its manufacturer or by his duly accredited representative.

3.2. It shall be accompanied by the undermentioned documents in triplicate and the following particulars:

3.2.1. a description of the motor cycle type with regard to the items mentioned in paragraph 2.2. above. The numbers and/or symbols identifying the engine type and the motor cycle type shall be specified;

3.2.2. a list of the components, duly identified, constituting the exhaust or exhaust or silencing system;

- 3.2.3. a drawing of the assembled exhaust or exhaust or silencing system and an indication of its position on the motor cycle;
- 3.2.4. detailed drawings of each component to enable it to be easily located and identified, and a specification of the materials used.
- 3.3. At the request of the technical service responsible for conducting approval tests, the motor cycle manufacturer shall, in addition, submit a sample of the exhaust or exhaust or silencing system.
- 3.4. A motor cycle representative of the motor cycle type to be approved shall be submitted to the technical service responsible for conducting approval tests.

4. MARKINGS

- 4.1. The components of the exhaust or silencing system shall bear:
 - 4.1.1. the trade name or mark of the manufacturer of the exhaust or silencing system and of its components;
 - 4.1.2. the trade description given by the manufacturer; and
 - 4.1.3. the approval mark [and the ECE approval number according to Annex 2 of the Regulation. The approval number must correspond to the number of the ECE type approval certificate issued for the type of exhaust or silencing system in question.]
 - 4.1.4. All original silencers must be bear the 'E' mark followed the identification of the country which granted the component type-approval. This reference must be legible and indelible and also visible in the position at which it is to be fitted.
 - 4.1.5. Any packing of original replacement silencer systems must be marked legibly with the words 'original part' and the make and type references integrated together with the 'E' mark and also the reference of the country of origin.

4.2. Such markings shall be clearly legible and be indelible.

5. APPROVAL

- 5.1. If the motor cycle type submitted for approval pursuant to this Regulation meets the requirements of paragraphs 6. and 7. below, approval of that motor cycle type shall be granted.
- 5.2. An approval number shall be assigned to each type approved. Its first two digits indicate the series of amendments incorporating the most recent major technical amendments made to the Regulation

at the time of issue of the approval. The same Contracting Party may not assign the same number to the same motor cycle type equipped with another type of exhaust or silencing system, or to another motor cycle type.

- 5.3. Notice of approval or of refusal of approval of a motor cycle type pursuant to this Regulation shall be communicated to the Parties to the Agreement which apply this Regulation, by means of a form conforming to the model in Annex 1 to this Regulation and of drawings of the exhaust or silencing system, supplied by the applicant for approval in a format not exceeding A 4 (210 x 297 mm) or folded to that format and on an appropriate scale.
- 5.4. There shall be affixed, conspicuously and in a readily accessible place specified on the approval form, to every motor cycle conforming to a motor cycle type approved under this Regulation an international approval mark consisting of:
- 5.4.1. a circle surrounding the letter "E" followed by the distinguishing number of the country which has granted approval;^{1/}
- 5.4.2. the number of this Regulation, followed by the letter "R", a dash and the approval number to the right of the circle prescribed in paragraph 5.4.1.
- 5.5. If the motor cycle conforms to a motor cycle type approved, under one or more other Regulations annexed to the Agreement, in the country which has granted approval under this Regulation, the symbol prescribed in paragraph 5.4.1. need not be repeated; in such a case the Regulation and approval numbers and the additional symbols of all the Regulations under which approval has been granted in the country which has granted approval under this Regulation shall be placed in vertical columns to the right of the symbol prescribed in paragraph 5.4.1.
- 5.6. The approval mark shall be clearly legible and be indelible.

^{1/} 1 for Germany, ... 24 for Ireland, ... 27 for Slovakia, 28 for Belarus, 29 for Estonia, 30 (vacant), 31 for Bosnia and Herzegovina, 32 for Latvia, 33 (vacant), 34 for Bulgaria, 35-36 (vacant), 37 for Turkey, 38-39 (vacant), 40 for the former Yougoslav Republic of Macedonia, 41 (vacant), 42 for the European Community (Approvals are granted by its Member States using their respective ECE symbol), 43 for Japan, 44 (vacant), 45 for Australia and 46 for Ukraine. Subsequent numbers shall be assigned to other countries in the chronological order in which they ratify the Agreement Concerning the Adoption for Uniform Technical Prescriptions for Wheeled Vehicles, Equipment and Parts which can be fitted and/or be Used on Wheeled Vehicles, and the Conditions for Reciprocal Recognition of Approval Granted on the Basis of these Prescriptions, and the numbers thus assigned shall be communicated by the Secretary-General of the United Nations to the Contracting Parties to the Agreement.

- 5.7. The approval mark shall be placed close to or on the motor cycle data plate affixed by the manufacturer.
- 5.8. Annex 2 to this Regulation gives examples of arrangements of the approval mark.
- 5.9. The test report (see in Annex 1) shall at least include the following information:
- details of the test site (e.g. surface temperature, absorption coefficient etc.), test site location, site orientation and weather conditions including wind speed and air temperature, direction, barometric pressure, humidity;
 - the type of measuring equipment including the windscreen;
 - the A-weighted sound pressure level typical of the background noise;
 - the identification of the vehicle, its engine, its transmission system, including available transmission ratios, size and type of tyres, tyre pressure, tyre production type, power, test mass, power to mass ratio index, awot ref, aurban, vehicle length and location of the reference point; the transmission gears or gear ratios used during the test;
 - the vehicle speed and engine speed at the beginning of the period of acceleration and the location of the beginning of the acceleration;
 - the vehicle speed and engine speed at PP" and at end of the acceleration;
 - method used for calculation of the acceleration;
 - intermediate measurement results per gears used:
 - point of depressing accelerator,
 - awot,
 - Lwot,
 - Lcruise
 - final measurement results:
 - kp
 - k
 - Lurban
 - the auxiliary equipment of the vehicle, where appropriate, and its operating conditions;
 - all valid A-weighted sound pressure level values measured for each test, listed according to the side of the vehicle and the direction of the vehicle movement on the test site;
- and all relevant information necessary to obtain the different sound emission levels.

6. SPECIFICATIONS

6.1. General specifications

- 6.1.1. The following information shall be provided on the motor cycle in an easily accessible but not necessarily immediately visible location:
- (a) the manufacturer's name
 - (b) the value in dB(A) recorded during the stationary test required by paragraph 6.2.1.1.
 - (c) the engine speed at $\frac{3}{4} S$ if S does not exceed 5000 min^{-1} , or at $\frac{1}{2} S$ if S exceeds 5000 min^{-1}
- 6.2. Specifications regarding sound levels
- 6.2.1. Methods of measurement
- 6.2.1.1. The noise made by the motor cycle type submitted for approval shall be measured by the two methods described in Annex 3 to this Regulation for the motor cycle in motion and for the motor cycle when stationary.^{2/}
- 6.2.1.2. The two values measured in accordance with the provisions of paragraph 6.2.1.1. above shall be entered in the test report and on a form conforming to the model in Annex 1 to this Regulation.
- 6.2.1.3. The sound level measured by the method described in Annex 3, paragraph 1.5. to this Regulation when the motor cycle is in motion shall not exceed the limits prescribed (for new motor cycles and new exhaust or silencing systems) in Annex 6 to this Regulation for the category to which the motor cycle belongs.
- 6.3. Additional specifications regarding exhaust or silencing systems or components filled with fibrous material
- 6.3.1. If the motor cycle is fitted with a device designed to reduce the exhaust noise (silencer), the requirements of Annex 5 shall apply. If the inlet of the engine is fitted with an air filter and/or an intake-noise absorber which is (are) necessary in order to ensure compliance with the permissible sound level, the filter and/or absorber shall be considered to be part of the silencer, and the requirements of Annex 5 shall also apply to them.
- 6.3.2. A diagram and a cross-sectional drawing indicating the dimensions of the exhaust system shall be appended to the certificate referred to in annex 1.

^{2/} A test is made on a stationary motor cycle in order to provide a reference value for administrations which use this method to check motor cycles in use. In addition to this stationary test, also a test in motion is available for Administrations to check motor cycles in use.

- 6.3.3. The silencer must be marked with a clearly legible and indelible reference to its make and type.
- 6.4. **Additional sound emission provisions**
- 6.4.1. The vehicle manufacturer shall not intentionally alter, adjust, or introduce any device or procedure solely for the purpose of fulfilling the noise emission requirements of this Regulation, which will not be operational during typical on-road operation.
- 6.4.2. Any control device, function, system or measure that could affect the noise output may be installed on a vehicle provided that:
- it is activated only for such purposes as engine protection, cold starting or warming up, or
 - it is activated only for such purposes as operational security or safety and limp-home strategies, or
 - it is required to fulfil other regulations.
- 6.4.3. The sound emission of the vehicle measured by the method described in Annex 7 to this Regulation shall not exceed the limits prescribed (for new motor cycles and new exhaust or silencing systems) in Annex 7 to this Regulation. This is fulfilled if the manufacturer provides a statement of compliance for the motor cycle type submitted for approval. The technical service may carry out Annex 7 tests to verify this requirement.
- 6.5. **Additional prescriptions related to tamperability and manually adjustable multi-mode exhaust or silencing systems**
- 6.5.1. All exhaust or silencing systems shall be constructed in way that does not easily permit removal of baffles, exit-cones and other parts whose primary function is as part of the silencing/expansion chambers. Where incorporation of such a part is unavoidable, its method of attachment shall be such that removal is not facilitated easily (e.g. with conventional threaded fixings) and should also be attached such that removal causes permanent/ irrecoverable damage to the assembly.
- 6.5.2. Exhaust or silencing systems with multiple, manually adjustable operating modes shall meet all requirements in all operating modes. The reporting noise levels shall be those resulting from the mode with the highest noise levels.
7. MODIFICATION AND EXTENSION OF THE APPROVAL OF THE MOTORCYCLE TYPE OR OF THE TYPE OF EXHAUST OR SILENCING SYSTEM(S)
- 7.1. Every modification of the motor cycle type or of the exhaust or silencing system shall be notified to the administrative department which approved the motor cycle type. The said department may then either:
- 7.1.1. consider that the modifications made are unlikely to have appreciable adverse effects, and that in any case the motor cycle still complies with the requirements; or

- 7.1.2. require a further test report from the technical service responsible for conducting the tests.
- 7.2. Confirmation or refusal of approval, specifying the alterations, shall be communicated by the procedure specified in paragraph 5.3. above to the Parties to the Agreement which apply this Regulation.
- 7.3. The competent authority which issued the approval extension shall assign a serial number to the extension and shall so notify the other Parties to the 1958 Agreement applying this Regulation, by means of a communication form conforming to the model in annex 1 to this Regulation.

8. CONFORMITY OF PRODUCTION

The conformity of production procedures shall comply with those set out in the Agreement, Appendix 2 (E/ECE/324-E/ECE/TRANS/505/Rev.2), with the following requirements :

- 8.1. Any motorcycle manufactured must conform to a type of motorcycle approved pursuant to this Regulation, be equipped with the silencer with which it was type-approved and satisfy the requirements paragraph 6 above.
- 8.2. In order to test conformity as required above, a sample motorcycle will be taken from the production line of the type approved pursuant to this Regulation. Production will be regarded as conforming to the provisions of this Regulation if the sound level ~~measured~~ **calculated** using the method described in annex 3 does not exceed by more than 3 dB(A) the value ~~measured~~ **calculated** at the time of type-approval, nor by more than 1 dB(A) the limits laid down in annex 6 of this Regulation.
- 8.3. Dedicated COP provisions for ASEP**
Production will be regarded as conforming to the provisions of this Regulation if the sound levels measured using the method described in annex 7 do not exceed by more than 1 dB(A) the limits laid down in annex 7 of this Regulation.

9. PENALTIES FOR NON-CONFORMITY OF PRODUCTION

- 9.1. The approval granted in respect of a motor cycle type pursuant to this Regulation may be withdrawn if the requirements laid down in paragraph 8.1. above are not complied with, or if the motor cycle has failed to pass the tests provided for in paragraphs **8.2. and 8.3.** above.
- 9.2. If a Party to the Agreement which applies this Regulation withdraws an approval it has previously granted, it shall forthwith so notify the other Contracting Parties applying this

Regulation by means of a communication form conforming to the model in Annex 1 to this Regulation.

10. PRODUCTION DEFINITELY DISCONTINUED

If the holder of the approval completely ceases to manufacture a type of a motor cycle approved in accordance with this Regulation, he shall inform the authority which granted the approval. Upon receiving the relevant communication, that authority shall inform thereof the other Parties to the Agreement applying this Regulation by means of a communication form conforming to the model in Annex 1 to this Regulation.

11. NAMES AND ADDRESSES OF TECHNICAL SERVICES RESPONSIBLE FOR CONDUCTING APPROVAL TESTS, AND OF ADMINISTRATIVE DEPARTMENTS

The Parties to the 1958 Agreement applying this Regulation shall communicate to the United Nations Secretariat the names and addresses of the technical services responsible for conducting approval tests and of the administrative departments which grant approval and to which forms certifying approval or extension or refusal or withdrawal of approval, issued in other countries, are to be sent.

12. TRANSITIONAL PROVISIONS

12.1. As from the official date of entry into force of the 04 series of amendments, no Contracting Parties applying this Regulation shall refuse to grant ECE approval under this Regulation as amended by the 04 series of amendments.

12.2. As from the date of entry into force of the 04 series of amendments, Contracting Parties applying this Regulation shall grant ECE approvals only if the motorcycle type to be approved meets the requirements of this Regulation as amended by the 04 series of amendments.

12.3. Contracting Parties applying this Regulation shall not refuse to grant extensions of approval in accordance with the preceding series of amendments to this Regulation.

12.4. Contracting Parties applying this Regulation shall continue to grant approvals to those types of motorcycles which conform to the requirements of this Regulation as amended by the preceding series of amendments until the entry into force of the 04 series of amendments.

12.5. ECE approvals granted under this Regulation before the entry into force of the 04 series of amendments and all extensions of such

approvals, including those granted subsequently under a preceding series of amendments to this Regulation, shall remain valid indefinitely. When the motorcycle type approved under the preceding series of amendments meets the requirements of this Regulation as amended by the 04 series of amendments, the Contracting Party which granted the approval shall so notify the other Contracting Parties applying this Regulation.

12.6. No Contracting Party applying this Regulation shall refuse national type approval of a motorcycle type approved under the 04 series of amendments to this Regulation or meeting the requirements thereof.

12.7. As from [dd/mm/yyyy](#) Contracting Parties applying this Regulation may refuse first national registration (first entry into service) of a motorcycle which does not meet the requirements of the 03 series of amendments to this Regulation.

Annex 1

COMMUNICATION

(Maximum format: A4 (210 x 297 mm))

issued by: Name of administration:
.....
.....
.....



concerning: 2/ APPROVAL GRANTED
APPROVAL EXTENDED
APPROVAL REFUSED
APPROVAL WITHDRAWN
PRODUCTION DEFINITELY DISCONTINUED

of a motor cycle type with regard to noise emitted by motor cycles pursuant to Regulation No. 41

Approval No. Extension No.

-
1. Trade name or mark of the motor cycle
 2. Motor cycle type
 3. Manufacturer's name and address
 4. If applicable, name and address of manufacturer's representative
.....
.....
 5. Engine:
 - 5.1. Manufacturer:
 - 5.2. Type:
 - 5.3. Model:
 - 5.4. Rated maximum power (ECE): kW at min-1 (rpm).
 - 5.5. Kind of engine: e.g. positive-ignition, compression ignition, etc. 3/
.....
 - 5.6. Cycles: two stroke or four-stroke
 - 5.7. Cylinder capacity
 6. Transmission: non-automatic gearbox/automatic gearbox 2/
 - 6.1. Number of gears
 7. Equipment:
 - 7.1. Exhaust silencer:
 - 7.1.1. Manufacturer or authorized representative (if any)
 - 7.1.2. Model:

- 7.1.3. Type: in accordance with drawing No.:
- 7.2. Intake silencer:
- 7.2.1. Manufacturer or authorized representative (if any)
- 7.2.2. Model:
- 7.2.3. Type: in accordance with drawing No.:
8. Gears used **.(main test, ASEP, roadside-check)**.....
9. Final drive ratio(s)
10. Type and dimensions of tyres
11. Maximum permissible gross weight, **test mass and power to mass ratio (PMR)**.....
12. **Vehicle length**
13. The vehicle speed and engine speed at the beginning of the period of acceleration, and the location of the beginning of the acceleration **(average of 3 runs)**
14. The vehicle speed and engine speed at PP' and at end of the acceleration **(average of 3 runs)**
15. Method used for calculation of the acceleration
17. **Noise level of moving vehicle:**
 Test result (L_{urban}): dB(A)
 Test result (L_{wot}):dB(A)
 Test result (L_{cruise}): dB(A)
 kp - factor:
18. **Noise level of stationary vehicle:**
 Position and orientation of microphone (according to figure 1 in Appendix of Annex 3)
- Test result for stationary test: dB(A)
19. **Additional sound emission provisions (where tested):**
 Reference point: Gear..., Lwot_i....dB(A) at rpm (PP')
 Measured points: I) Gear..., Lwot_i....dB(A) at rpm (PP')
 II) Gear..., Lwot_i....dB(A) at rpm (PP')
 III) Gear..., Lwot_i....dB(A) at rpm (PP')
20. **Additional roadside enforcement:**
 Reference point: Gear..., Lwot_i....dB(A) at km/h entry speed (V_{AA'})
21. Deviations in calibration of sound level meter
22. Motor cycle submitted for approval on
23. Technical service responsible for conducting approval tests
24. Date of report issued by that service
25. Number of report issued by that service
26. Approval granted/extended/refused/withdrawn 2/
27. Position of approval mark on the motor cycle
28. Place
29. Date
30. Signature
31. The following documents, bearing the approval number shown above, are annexed to this communication:
 ...drawings, diagrams and plans of the engine and of the noise reduction system;
 ...photographs of the engine and of the exhaust or silencing system;
 ...list of components, duly identified constituting the noise reduction

system.

-
- 1/ Distinguishing number of the country which has granted / extended / refused / withdrawn approval (see approval provisions in the Regulation).
 - 2/ Strike out what does not apply.
 - 3/ If a non-conventional engine is used, this should be stated.

Annex 2

ARRANGEMENTS OF APPROVAL MARKS

Model A

(See paragraph 5.4. of this Regulation)

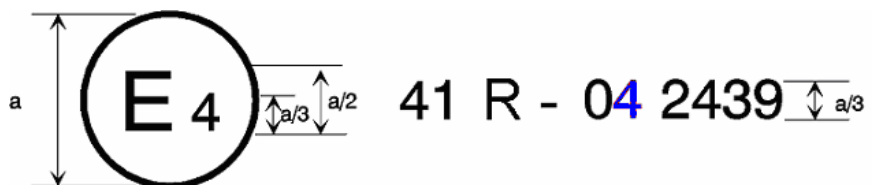

a = 8 mm min.

The above approval mark affixed to a motor cycle shows that the motor cycle type concerned has, with regard to noise, been approved in the Netherlands (E 4) pursuant to Regulation No. 41 under approval number 042439. The first two digits of the approval number indicate that the approval was granted in accordance with the requirements of Regulation No. 41 as amended by the 04 series of amendments.

Model B

(See paragraph 5.5 of this Regulation)

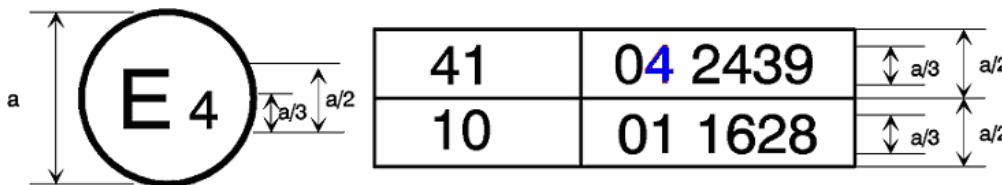

a = 8 mm min.

The above approval mark affixed to a motor cycle shows that the motor cycle type concerned has been approved in the Netherlands (E 4) pursuant to Regulations Nos. 41 and 10. */ The first two digits of the approval numbers indicate that on the date on which these approvals were granted, Regulation No. 41 included 04 series of amendments and Regulation No. 10 included the 01 series of amendments.

*/ The second number is given merely as an example.

Annex 3

METHODS AND INSTRUMENTS FOR MEASURING NOISE MADE BY MOTOR CYCLES

1. Noise of the motorcycle in motion (measuring conditions and method for testing of the vehicle during component type approval).

1.1. Limits: see annex 6

1.2. Measuring instruments

1.2.1. Acoustic measurements

1.2.1.1 General

The apparatus used for measuring the sound pressure level shall be a sound level meter or equivalent measuring system meeting the requirements of Class 1 instruments (inclusive of the recommended windscreen, if used). These requirements are described in IEC 61672-1:2002.

The entire measuring system shall be checked by means of a sound calibrator that fulfils the requirements of Class 1 sound calibrators according to IEC 60942:2003.

Measurements shall be carried out using the time weighting "F" of the acoustic measuring instrument and the "A" frequency weighting curve also described in IEC 61672-1:2002. When using a system that includes periodic monitoring of the A-weighted sound pressure level, a reading should be made at a time interval not greater than 30 ms.

The instruments shall be maintained and calibrated in accordance to the instructions of the instrument manufacturer.

1.2.1.2 Calibration

At the beginning and at the end of every measurement session, the entire acoustic measuring system shall be checked by means of a sound calibrator as described in 1.2.1.1. Without any further adjustment, the difference between the readings shall be less than or equal to 0,5 dB. If this value is exceeded, the results of the measurements obtained after the previous satisfactory check shall be discarded.

1.2.1.3 Compliance with requirements

Compliance of the sound calibrator with the requirements of IEC 60942:2003 shall be verified once a year. Compliance of the instrumentation system with the requirements of IEC 61672-1:2002 shall be verified at least every 2 years. All compliance testing shall be conducted by a laboratory which is authorized to perform calibrations traceable to the appropriate standards.

1.2.2. Instrumentation for speed measurements

The rotational speed of the engine shall be measured with an

instrument meeting specification limits of at least $\pm 2\%$ or better at the engine speeds required for the measurements being performed.

The road speed of the vehicle shall be measured with instruments meeting specification limits of at least $\pm 0,5$ km/h when using continuous measuring devices.

If testing uses independent measurements of speed, this instrumentation shall meet specification limits of at least $\pm 0,2$ km/h.

NOTE Independent measurements of speed are when two or more separate devices will determine the vAA' vBB' and vPP' values. A continuous measuring device will determine all required speed information with one device.

1.2.3. Meteorological instrumentation

The meteorological instrumentation used to monitor the environmental conditions during the test shall meet the following specifications:

- ± 1 °C or less for a temperature measuring device;
- $\pm 1,0$ m/s for a wind speed measuring device;
- ± 5 hPa for a barometric pressure measuring device;
- $\pm 5\%$ for a relative humidity measuring device.

1.3. Acoustical environment, meteorological conditions and background noise

1.3.1. Test site

The test site shall consist of a central acceleration section surrounded by a substantially level test area. The acceleration section shall be level; its surface shall be dry and so designed that rolling noise remains low.

On the test site the variations in the free sound field between the sound source at the centre of the acceleration section and the microphone shall be maintained to within 1 dB. This condition will be deemed to be met if there are no large objects which reflect sound, such as fences, rocks, bridges or buildings, within 50 m of the centre of the acceleration section. The road surface covering of the test site shall conform to the requirements of annex 4.

The microphone shall not be obstructed in any way which could affect the sound field, and no person may stand between the microphone and the sound source. The observer carrying out the measurements shall take up position so as not to affect the readings of the measuring instrument.

1.3.2. Meteorological conditions

The meteorological instrumentation shall deliver data representative of the test site, and shall be positioned adjacent to the test area at a height representative of the height of the measuring microphone.

The measurements shall be made when the ambient air temperature is within the range from 5 °C to 40 °C. The tests shall not be

carried out if the wind speed, including gusts, at microphone height exceeds 5 m/s, during the noise measurement interval. A value representative of temperature, wind speed and direction, relative humidity and barometric pressure shall be recorded during the noise measurement interval.

~~NOTE Refer to Annex B for the effects of temperature and other factors.~~

1.3.3. Background noise

Any sound peak which appears to be unrelated to the characteristics of the general noise level of the vehicle shall be ignored in taking the readings.

The background noise shall be measured for duration of 10 s immediately before and after a series of vehicle tests. The measurements shall be made with the same microphones and microphone locations used during the test. The maximum A-weighted sound pressure level shall be reported.

The background noise (including any wind noise) shall be at least 10 dB below the A-weighted sound pressure level produced by the vehicle under test. If the difference between the background sound pressure level and the measured sound pressure level is between 10 dB and 15 dB, in order to calculate the jth test result the appropriate correction shall be subtracted from the readings on the sound level meter, as given in Table 1.

Table 1 – Correction applied to individual measured test value

Background sound pressure level difference to measured sound pressure level, in dB	10	11	12	13	14	greater or equal to 15
Correction, in dB	0,5	0,4	0,3	0,2	0,1	0,0

1.4. Specification of the acceleration

1.4.1. General

All accelerations are calculated using different speeds of the vehicle on the test track. The formulas given in 1.4.2. are used for the calculation of $a_{\text{wot } i}$, $a_{\text{wot } (i+1)}$ and $a_{\text{wot test}}$. The speed either at AA' ($v_{\text{AA}'}$) or PP' ($v_{\text{PP}'}$) is defined by the vehicle speed when the reference point passes AA' or PP'. The speed at BB' ($v_{\text{BB}'}$) is defined when the rear of the vehicle passes BB'. The method used for determination of the acceleration shall be indicated in the test report.

With the front of the vehicle as reference point, $l_{\text{ref}} = l_{\text{veh}}$ is the length of vehicle.

The dimensions of the test track are used in the calculation of acceleration. These dimensions are defined as follows: $l_{20} = 20$ m, $l_{10} = 10$ m.

Due to the large variety of technologies, it is necessary to consider different modes of calculation. New technologies (such as continuously variable transmission) and older technologies (such as automatic transmission) which have no electronic control, require a more specific treatment for a proper determination of the acceleration. The given possibilities for calculation of the acceleration shall cover these needs.

1.4.2. Calculation of acceleration

1.4.2.1. Calculation procedure for vehicles with manual transmission, automatic transmission, adaptive transmission and continuously variable transmission (CVT) tested with locked gear ratios

Calculate $a_{\text{wot test, } j}$ using the equation:

$$a_{\text{wot test, } j} = ((v_{\text{BB}'}/3,6)^2 - (v_{\text{AA}'}/3,6)^2) / (2*(l_{20}+l_{\text{ref}})) \quad (2)$$

where

$a_{\text{wot test, } j}$ is the numerical value of acceleration, expressed in metres per second squared;

$v_{\text{BB}'}$, $v_{\text{AA}'}$ are numerical values of velocity, expressed in kilometres per hour;

l_{20} , l_{ref} are numerical values of length, expressed in metres.

Pre-acceleration may be used.

1.4.2.2. Calculation procedure for vehicles with automatic transmission, adaptive transmission and CVT tested with non-locked gear ratios

If devices or measures described in 1.5.3.1.3.2 may be used to control transmission operation for the purpose of achieving test requirements, calculate $a_{\text{wot test, } j}$ using Equation (2).

Pre-acceleration may be used.

If no devices or measures described in 1.5.3.1.3.2 are used, calculate $a_{\text{wot test, } j}$ using the equation:

$$a_{\text{wot test, } j} = ((v_{\text{BB}'}/3,6)^2 - (v_{\text{PP}'}/3,6)^2) / (2*(l_{10}+l_{\text{ref}})) \quad (3)$$

where

$a_{\text{wot test, } j}$ is the numerical value of acceleration, expressed in metres per second squared;

$v_{\text{PP}'}$, $v_{\text{BB}'}$ are numerical values of velocity, expressed in kilometres per hour;

l_{10} , l_{ref} are numerical values of length, expressed in metres.

Pre-acceleration shall not be used.

~~NOTE It would be useful for these type of vehicles to record the vehicle speeds at AA', PP', and BB' to provide information for a future revision of this part of ISO 362.~~

1.4.2.3. Calculation of the target acceleration

Calculate a_{urban} using the equation:

$$a_{\text{urban}} = 1.37 * \log(\text{PMR}) - 1.08 \quad \text{for } 25 < \text{PMR} \leq 50 \quad (4)$$

$$a_{\text{urban}} = 1.28 * \log(\text{PMR}) - 1.19 \quad \text{for } \text{PMR} > 50 \quad (5)$$

where

a_{urban} is the numerical value of acceleration expressed in metres per second squared;

PMR is the dimensionless value of the power-to-mass index.

1.4.2.4. Calculation of the reference acceleration

Calculate $a_{\text{wot ref}}$ using the equation:

$$a_{\text{wot ref}} = 2.47 * \log(\text{PMR}) - 2.52 \quad \text{for } 25 < \text{PMR} \leq 50 \quad (6)$$

$$a_{\text{wot ref}} = 3.33 * \log(\text{PMR}) - 4.16 \quad \text{for } \text{PMR} > 50 \quad (7)$$

1.4.2.5. Partial power factor k_p

Partial power factor k_p is:

$$k_p = 1 - (a_{\text{urban}} / a_{\text{wot test}}) \quad (8)$$

In cases other than a single gear test $a_{\text{wot ref}}$ shall be used instead of $a_{\text{wot test}}$ as defined in [1.5.4.3.1](#).

1.5. Test procedures

1.5.1. Microphone positions

The distance from the microphone positions on the microphone line PP', perpendicular to the reference line CC' ([see Annex 4 - Figure 1](#)) on the test track shall be 7,5 m ± 0,05 m.

The microphone shall be located 1,2 m ± 0,02 m above the ground level. The reference direction for free-field conditions (see IEC 61672-1:2002) shall be horizontal and directed perpendicularly towards the path of the vehicle line CC'.

1.5.2. Conditions of the vehicle

1.5.2.1. General Conditions

The vehicle shall be supplied as specified by the vehicle manufacturer.

Before the measurements are started, the vehicle shall be brought to its normal operating conditions.

The variation of results between runs may be reduced if there is an approximate 60 s wait, at idle in neutral, between runs.

If the motorcycle is fitted with fans with an automatic actuating mechanism, this system shall not be interfered with during the sound measurements. For motorcycles having more than one driven wheel, only the drive provided for normal road operation may be used. Where a motorcycle is fitted with a sidecar, this must be removed for the purposes of the test.

1.5.2.2. Test mass of the vehicle

Measurements shall be made on vehicles at the test mass m_t , in kg, specified as:

$m_t = m_{ref} = m_{kerb} + m_d = m_{kerb} + 75 \text{ kg} \pm 5 \text{ kg}$ (75 kg \pm 5 kg equates to mass of the driver m_d)

1.5.2.3. Tyre selection and condition

The tyres shall be appropriate for the vehicle and shall be inflated to the pressure recommended by the tyre manufacturer for the test mass of the vehicle.

For certification and related purposes, additional requirements for the tyres, defined by regulation, are necessary. The tyres for such a test shall be selected by the vehicle manufacturer, and correspond to one of the tyre size and type designated for the vehicle by the vehicle manufacturer. The tyre shall be commercially available on the market at the same time as the vehicle. The minimum tread depth shall be at least 80 % of the full tread depth.

NOTE The tread depth and pattern can have a significant influence on the test result.

1.5.3. Operating conditions

1.5.3.1. **Vehicles** with PMR > 25

1.5.3.1.1. General conditions

The path of the centerline of the vehicle shall follow line CC' as closely as possible throughout the entire test, from the approach to line AA' until the rear of the vehicle passes line BB' (see [Annex 4 - Figure 1](#)). Any trailer that is not readily separable from the towing vehicle shall be ignored when considering the crossing of the line BB'. If the vehicle is fitted with more than two-wheel drive, test it in the drive selection that is intended for normal road use. If the vehicle is fitted with an auxiliary manual transmission or a multi-gear axle, the position used for normal urban driving shall be used. In all cases, the gear ratios for slow movements, parking or braking, shall be excluded.

1.5.3.1.2. Test speed

The test speed v_{test} shall be:

40 km/h \pm 1 km/h for PMR \leq 50
50 km/h \pm 1 km/h for PMR > 50

The test speed shall be reached, when the reference point according to [2.6.6](#). passes line PP'. The test speed shall be reduced by increments of 10% of VPP in case the exit speed VBB exceeds 75% of Vmax.

1.5.3.1.3. Gear selection

It is the responsibility of the manufacturer to determine the correct manner of testing to achieve the required accelerations.

~~[Annex C gives gear selection criteria and test run criteria in a](#)~~

~~flowchart form as an aid to test operation.~~

1.5.3.1.3.1. Manual transmission, automatic transmissions, adaptive transmissions or transmissions with continuously variable gear ratios (CVTs) tested with locked gear ratios

The selection of gear ratios for the test depends on the specific acceleration potential $a_{wot, i}$ under full throttle condition according to the specification in 1.4.2. in relation to the reference acceleration $a_{wot, ref}$ required for the full-throttle acceleration test according to Equation (6) or Equation (7) in 1.4.2.4.

The following conditions for selection of gear ratios are possible.

- a) If there are two gear ratios that give acceleration in a tolerance band of $\pm 10\%$ of the reference acceleration $a_{wot, ref}$, both gear ratios shall be used for the test with the gear ratio weighting factor calculated as shown below;
- b) If only one specific gear ratio gives acceleration in the tolerance band of $\pm 10\%$ of the reference acceleration $a_{wot, ref}$, the test shall be performed with that gear ratio;
- c) If none of the gear ratios give the required acceleration, then choose a gear ratio i , with an acceleration higher and a gear ratio $(i + 1)$, with an acceleration lower than the reference acceleration $a_{wot, ref}$. Use both gear ratios for the test. The gear ratio weighting factor in relation to the reference acceleration $a_{wot, ref}$ is calculated by:

$$k = (a_{wot, ref} - a_{wot, (i+1)}) / (a_{wot, i} - a_{wot, (i+1)}) \quad (9)$$

If the vehicle has a transmission in which there is only one selection for the gear ratio, the full-throttle test is carried out in this vehicle gear selection. The achieved acceleration $a_{wot, test}$ is then used for the calculation of the partial power factor k_p (see 2.6.10) instead of $a_{wot, ref}$.

If rated engine speed is exceeded in a gear ratio before the vehicle passes BB', the next higher gear shall be used.

1.5.3.1.3.2. Automatic transmission, adaptive transmissions and transmissions with variable gear ratios tested with non-locked gear ratios

The gear selector position for full automatic operation shall be used.

The acceleration $a_{wot, test}$ shall be calculated by Equations (2) or (3) as specified in 1.4.2.2.

The test may then include a gear change to a lower gear ratio and a higher acceleration. A gear change to a higher range and a lower acceleration is not allowed. In any case, a gear shifting to a gear ratio which is typically not used at the specified condition in urban traffic shall be avoided.

Therefore, it is permitted to establish and use electronic or mechanical devices, including alternative gear selector positions, to prevent a downshift to a gear ratio which is typically not used at the specified test condition in urban traffic.

The achieved acceleration $a_{wot, test}$ shall be greater or equal to a_{urban} .

The achieved acceleration $a_{\text{wot test}}$ is then used for the calculation of the partial power factor k_p (see 2.6.10) instead of $a_{\text{wot ref}}$.

1.5.3.1.4. Acceleration test

The acceleration test shall be carried out in all gear ratios specified for the vehicle according to 1.5.3.1.3 with the test speed specified in 1.5.3.1.2.

When the front of the vehicle reaches AA', the acceleration control unit shall be fully engaged and held fully engaged until the rear of the vehicle reaches BB'. The acceleration control unit shall then be released. Pre-acceleration may be used if acceleration is delayed beyond AA'. The location of the start of the acceleration shall be reported.

The calculated acceleration $a_{\text{wot test}}$ shall be noted to the second digit after the decimal place.

1.5.3.1.5. Constant speed test

For vehicles with transmissions specified in 8.3.1.3.2, the constant speed test shall be carried out with the same gears specified for the acceleration test. For vehicles with transmissions specified in 1.5.3.1.3.2, the gear selector position for full automatic operation shall be used. If the gear is locked for the acceleration test, the same gear shall be locked for the constant speed test.

During the constant speed test, the acceleration control unit shall be positioned to maintain a constant speed between AA' and BB' as specified in 1.5.3.1.2.

1.5.3.2. Vehicles with PMR • 25

The only operating condition is a full throttle acceleration test. The general conditions specified in 1.5.3.1.1 shall apply. The initial test speed shall be as specified in 1.5.3.1.2. The test speed shall be reduced by decrements of 10 % in case the exit speed v_{BB} exceeds 75 % of v_{max} or in case the engine speed exceeds the rated engine speed S at BB'. The selected gear ratio shall be the lowest one without exceeding the rated engine speed S during the test. The final test conditions are determined by the lowest possible gear ratio at the highest possible test speed without exceeding 75 % of v_{max} and the rated engine speed S at BB'.

1.5.4. Measurement readings and reported values

1.5.4.1. General

At least **three** measurements for all test conditions shall be made on each side of the vehicle and for each gear ratio.

The maximum A-weighted sound pressure level indicated during each passage of the vehicle between AA' and BB' (see Annex 4 - Figure 1) shall be noted, to the first significant digit after the decimal place (e.g. XX,X). If a sound peak obviously out of character with the general sound pressure level is observed, that measurement shall be discarded.

The first **three** j th valid consecutive measurement results for any test condition, within 2,0 dB, allowing for the deletion of non-valid results, shall be used for the calculation of the appropriate intermediate or final result.

The speed measurements at AA' ($v_{AA'}$), BB' ($v_{BB'}$), and PP' ($v_{PP'}$) shall be noted and used in the calculations to one digit after the decimal place.

1.5.4.2. Data compilation

For a given test condition, the results of each side of the vehicle shall be averaged separately. The intermediate result shall be the higher value of the two averages mathematically rounded to the first decimal place.

All further calculations to derive L_{urban} shall be done separately for the left and right vehicle side. The final value to be reported as the test result shall be the higher value of the two sides.

1.5.4.3. Vehicles with PMR > 25

1.5.4.3.1. Acceleration

The acceleration for further use is the average acceleration of the **three** runs:

$$a_{wot\ test} = 1/3 (a_{wot\ test(1)} + a_{wot\ test(2)} + a_{wot\ test(3)} + \del{a_{wot\ test(4)}}) \quad (10)$$

where the numbers in brackets symbolize the test runs j .

1.5.4.3.2. Reported value and final results

The Communication referred to in annex 1 shall indicate all relevant data and particularly those used in measuring the noise of the motorcycle in motion and shall indicate any circumstances and influences affecting the results of the measurements.

Calculate the reported value $L_{wot\ rep}$ for the wide open throttle test using the equation:

$$L_{wot\ rep} = L_{wot\ (i+1)} + k (L_{wot(i)} - L_{wot\ (i+1)}) \quad (11)$$

where k is the gear ratio weighting factor.

Calculate the reported value $L_{crs\ rep}$ for the constant speed test using the equation:

$$L_{crs\ rep} = L_{crs\ (i+1)} + k (L_{crs\ i} - L_{crs\ (i+1)}) \quad (12)$$

In the case of a single gear ratio test, the reported values are directly derived from the test result itself.

The equations used to determine the partial power factor, k_p , are as follows:

- in cases other than a single gear test, k_p is calculated by:

$$k_p = 1 - (a_{urban} / a_{wot\ ref}) \quad (13)$$

- if only one gear was specified for the test, k_p is given by:

$$k_p = 1 - (a_{urban} / a_{wot\ test}) \quad (14)$$

- in cases where $a_{wot\ test}$ is less than a_{urban} :

$$k_p = 0 \quad (15)$$

The final result is calculated by combining Equation (11) for $L_{wot\ rep}$ and Equation (12) for $L_{crs\ rep}$

$$L_{urban} = L_{wot\ rep} - k_p (L_{wot\ rep} - L_{crs\ rep}) \quad (16)$$

If the **final result** does not exceed the maximum permissible level for the category to which the motorcycle being tested belongs, the limit laid down in paragraph 1.1. will be deemed as being complied with. This **average** value will constitute the result of the test.

1.5.4.4. Vehicles of with PMR • 25

The intermediate result in 1.5.4.2 shall be the final result.

If the **final result** does not exceed the maximum permissible level for the category to which the motorcycle being tested belongs, the limit laid down in paragraph 1.1. will be deemed as being complied with. This **average** value will constitute the result of the test.

2. Noise from stationary motorcycle (measuring conditions and method for testing of the vehicle in use).

2.1. Sound-pressure level in the immediate vicinity of the motorcycle

In order to facilitate subsequent noise tests on motorcycles in use, the sound-pressure level shall also be measured in the immediate vicinity of the exhaust-system outlet in accordance with the following requirements, the result of the measurement being entered in the communication referred to in annex 1.

2.2. Measuring instruments

A precision sound-level meter as defined in paragraph 1.2.1. shall be used.

2.3. Conditions of measurement

2.3.1. Condition of the motorcycle

Before the measurements are made the motorcycle engine shall be brought to the normal operating temperature.
If the motorcycle is fitted with fans with an automatic actuating mechanism, this system shall not be interfered with during the sound measurements.
During the measurements the gearbox shall be in neutral gear. If it is impossible to disconnect the transmission, the driving wheel of the motorcycle shall be allowed to rotate freely, for example by placing the vehicle on its centre stand.

2.3.2. Test site (See appendix - figure 1)

Any area in which there are no significant acoustic disturbances may be used as a test site. Flat surfaces which are covered with concrete, asphalt or some other hard material and are highly reflective are suitable; surfaces consisting of earth which has been tamped down shall not be used. The test site must be in the form of a rectangle whose sides are at least 3 m from the outer edge of the motorcycle (handlebars excluded). There shall be no significant obstacles, e.g. no persons other than the rider and the observer may stand within this rectangle.

The motorcycle shall be positioned within the said rectangle so that the microphone used for measurement is at least 1 m from any kerb.

2.3.3. Miscellaneous

Readings of the measuring instrument caused by ambient noise and wind effects shall be at least 10 dB(A) lower than the sound levels to be measured. A suitable windshield may be fitted to the microphone provided that account is taken of its effect on the sensitivity of the microphone.

2.4. Method of measurement

2.4.1. Nature and number of measurements

The maximum sound level expressed in A-weighted decibels (dB(A)) shall be measured during the period of operation laid down in paragraph 2.4.3.

At least three measurements shall be taken at each measuring point.

2.4.2. Positioning of the microphone (See appendix - figure 1)

The microphone shall be positioned level with the exhaust outlet or 0.2 m above the surface of the track, whichever is the highest. The microphone diaphragm shall face towards the exhaust outlet at a distance of 0.5 m from it. The axis of maximum sensitivity of the microphone shall be parallel to the surface of the track at an angle of $45^\circ \pm 10'$ to the vertical plane of the direction of the exhaust emissions.

In relation to this vertical plane, the microphone shall be located on the side which gives the maximum possible distance between the microphone and the outline of the motorcycle (handlebars excluded).

If the exhaust system has more than one outlet at centres less than 0.3 m apart, the microphone shall be faced towards the outlet which is nearest the motorcycle (handlebars excluded) or towards the outlet which is highest above the surface of the track. If the centres of the outlets are more than 0.3 m apart, separate measurements shall be taken for each of them, the highest figure recorded being taken as the test value.

2.4.3. Operating conditions

The engine speed shall be held steady at one of the following values:

$S/2$ if S is more than 5000 rpm,

$3S/4$, if S is not more than 5000 rpm

where S is the speed specified under item 9 of annex 1.

When a constant engine speed is reached, the throttle shall be returned swiftly to the idle position. The sound level shall be

measured during an operating cycle consisting of a brief period of constant engine speed and throughout the deceleration period, the maximum sound-level meter reading being taken as the test value.

2.5. Results

2.5.1. The Communication referred to in annex 1 shall indicate all relevant data and particularly those used in measuring the noise of the stationary motorcycle.

2.5.2. Values, rounded off to the nearest decibel, shall be read off the measuring instrument.
If the figure following the decimal point is between 0 and 4, the total is rounded down and if between 5 and 9, it is rounded up.

Only those measurements which vary by no more than 2 dB(A) in three consecutive tests will be used.

2.5.3. The highest of the three measurements will constitute the test result.

3. Noise from motorcycle in motion (measuring conditions and method for testing of the vehicle in use).

In order to facilitate subsequent noise tests on motorcycles in use, the following data relating to the sound-pressure level measurements carried out in accordance with annex 3 for the motorcycle in motion, shall be entered in the communication referred to in annex 1:

- $L_{wot,i}$: the highest result of the full throttle acceleration tests in gear i as from section 1 to annex 3

- $VAA'_{wot,i}$: the vehicle speed at AA' in km/h for the full throttle acceleration test in gear i resulting in the [highest] recorded $L_{wot,i}$

- gear i

Figure 1

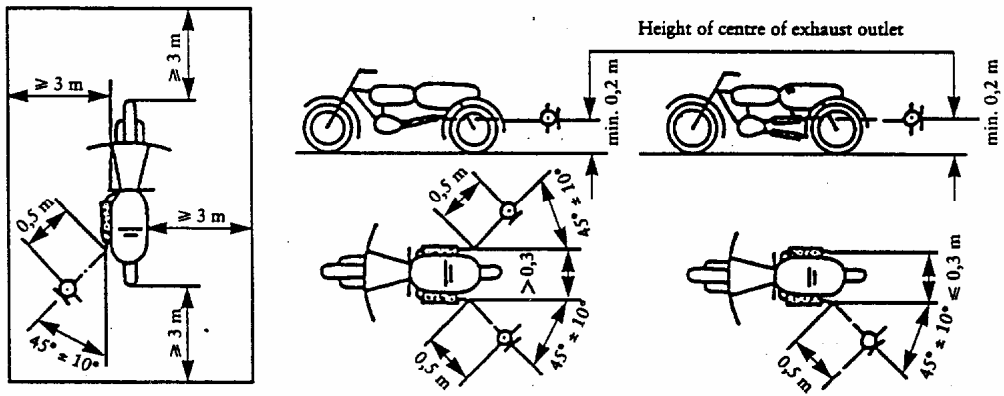

Test for stationary vehicle

Annex 4

SPECIFICATIONS FOR THE TEST SITE

1. Introduction

This annex describes the specifications relating to the physical characteristics and the laying of the test track. These specifications, based on a special standard, [†]/ describe the required physical characteristics as well as the test methods for these characteristics.

2. Required characteristics of the surface

A surface is considered to conform to this standard provided that the texture and voids content or sound absorption coefficient have been measured and found to fulfil [all] the requirements of paragraphs 2.1. to 2.4. below and provided that the design requirements (para. 3.2.) have been met.

2.1. Residual voids content

The residual voids content, V_c , of the test track paving mixture shall not exceed 8 per cent. For the measurement procedure, see paragraph 4.1.

2.2. Sound absorption coefficient

If the surface fails to conform to the residual voids content requirement, the surface is acceptable only if its sound absorption coefficient, α , ≤ 0.10 . For the measurement procedure, see paragraph 4.2. The requirement of paragraphs 2.1. and 2.2. is met also if only sound absorption has been measured and found to be $\alpha \leq 0.10$.

Note: The most relevant characteristic is the sound absorption, although the residual voids content is more familiar among road constructors. However, sound absorption needs to be measured only if the surface fails to conform to the voids requirement. This is because the latter is connected with relatively large uncertainties in terms of both measurements and relevance and some surfaces may therefore be rejected erroneously when the voids measurement only is used as a basis.

2.3. Texture depth

The texture depth (TD) measured according to the volumetric method (see para. 4.3. below) shall be:

$$TD \geq 0.4 \text{ mm}$$

[†]/ ISO 10844:1994

2.4. Homogeneity of the surface

Every practical effort shall be taken to ensure that the surface is made to be as homogeneous as possible within the test area. This includes the texture and voids content, but it should also be observed that if the rolling process results in more effective rolling at some places than others, the texture may be different and unevenness causing bumps may also occur.

2.5. Period of testing

In order to check whether the surface continues to conform to the texture and voids content or sound absorption requirements stipulated in this standard, periodic testing of the surface shall be done at the following intervals:

(a) For residual voids content or sound absorption:

when the surface is new;
if the surface meets the requirements when new, no further periodical testing is required. If it does not meet the requirement when it is new, it may do later because surfaces tend to become clogged and compacted with time.

(b) For texture depth (TD):

when the surface is new;
when the noise testing starts (NB: not before four weeks after laying);
then every 12 months.

3. Test surface design

3.1. Area

When designing the test track layout it is important to ensure that, as a minimum requirement, the area traversed by the vehicles running through the test strip is covered with the specified test material with suitable margins for safe and practical driving. This will require that the width of the track is at least 3 m and the length of the track extends beyond lines AA and BB by at least 10 m at either end. Figure 1 shows a plan of a suitable test site and indicates the minimum area which shall be machine laid and machine compacted with the specified test surface material. According to annex 3, paragraph 1.5.4.1., measurements have to be made on each side of the vehicle. This can be made either by measuring with two microphone locations (one on each side of the track) and driving in one direction, or measuring with a microphone only on one side of the track but driving the vehicle in two directions. If the former method is used, then there are no surface requirements on that side of the track where there is no microphone.

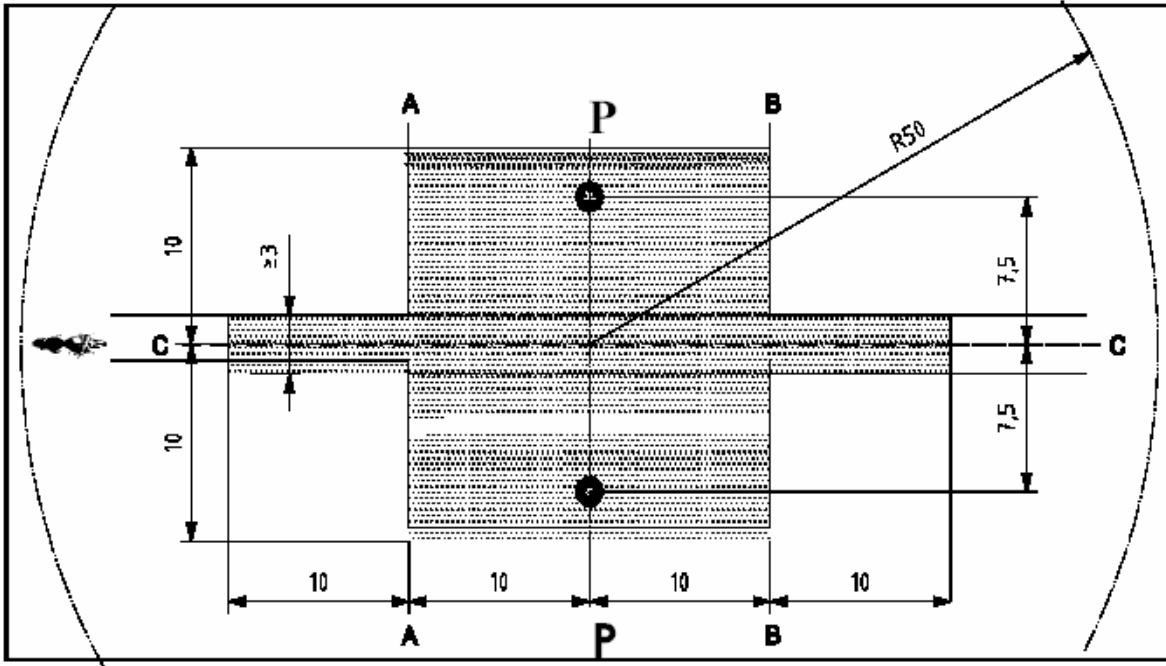

Key



-  minimum area covered with test road surface, i.e. test area
-  microphone positions (height 1,2 m)

Figure 1: Minimum requirements for test surface area. The shaded part is called "Test Area".

3.2. Design and preparation of the surface

3.2.1. Basic design requirements

The test surface shall meet four design requirements:

- 3.2.1.1. It shall be a dense asphaltic concrete.
- 3.2.1.2. The maximum chipping size shall be 8 mm (tolerances allow from 6.3 to 10 mm).
- 3.2.1.3. The thickness of the wearing course shall be ≥ 30 mm.
- 3.2.1.4. The binder shall be a straight penetration grade bitumen without modification.

3.2.2. Design guidelines

As a guide to the surface constructor, an aggregate grading curve which will give desired characteristics is shown in Figure 2. In addition, Table 1 gives some guidelines in order to obtain the desired texture and durability. The grading curve fits the following formula:

$$P (\% \text{ passing}) = 100 \cdot (d/d_{\max})^{1/2}$$

where: d = square mesh sieve size, in mm

d_{max} = 8 mm for the mean curve
 d_{max} = 10 mm for the lower tolerance curve
 d_{max} = 6.3 mm for the upper tolerance curve

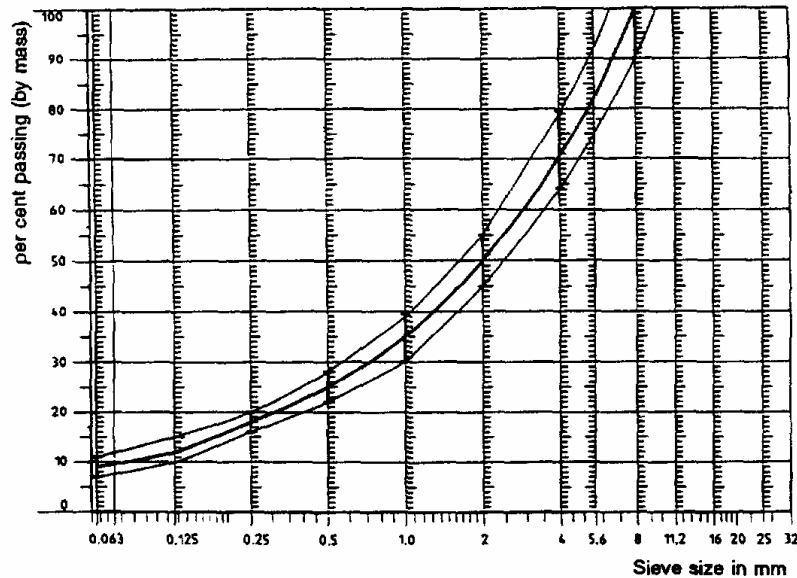

Figure 2: Grading curve of the aggregate in the asphaltic mix with tolerances

In addition to the above, the following recommendations are given:

The sand fraction (0.063 mm < square mesh sieve size < 2mm) shall include no more than 55% natural sand and at least 45% crushed sand;

The base and sub-base shall ensure a good stability and evenness, according to best road construction practice;

The chippings shall be crushed (100% crushed faces) and of a material with a high resistance to crushing;

The chippings used in the mix shall be washed;

No extra chippings shall be added onto the surface;

The binder hardness expressed as PEN value shall be 40-60, 60-80 or even 80-100 depending on the climatic conditions of the country. The rule is that as hard a binder as possible shall be used, provided this is consistent with common practice;

The temperature of the mix before rolling shall be chosen so as to achieve by subsequent rolling the required voids content. In order to increase the probability of satisfying the specifications of paragraphs 2.1. to 2.4. above, the compactness shall be studied not only by an appropriate choice of mixing temperature, but also by an appropriate number of passings and by the choice of compacting vehicle.

Table 1: Design guidelines

	Target values		Tolerances
	By total mass of mix	By mass of the aggregate	
Mass of stones, square mesh sieve (SM) > 2 mm	47.6%	50.5%	± 5
Mass of sand 0.063 < SM < 2 mm	38.0%	40.2%	± 5
Mass of filler SM < 0.063 mm	8.8%	9.3%	± 2
Mass of binder (bitumen)	5.8%	N.A.	± 0.5
Max. chipping size		8 mm	6.3 - 10
Binder hardness	(see para. 3.2.2. (f))		
Polished stone value (PSV)		> 50	
Compactness, relative to Marshall compactness		98%	

4. Test method

4.1. Measurement of the residual voids content

For the purpose of this measurement, cores have to be taken from the track in at least four different positions which are equally distributed in the test area between lines AA and BB (see Figure 1).

In order to avoid inhomogeneity and unevenness in the wheel tracks, cores should not be taken in wheel tracks themselves, but close to them. Two cores (minimum) should be taken close to the wheel tracks and one core (minimum) should be taken approximately midway between the wheel tracks and each microphone location.

If there is a suspicion that the condition of homogeneity is not met (see para. 2.4.), cores shall be taken from more locations within the test area. The residual voids content has to be determined for each core, then the average value from all cores shall be calculated and compared with the requirement of paragraph 2.1. In addition, no single core shall have a voids value which is higher than 10%. The test surface constructor is reminded of the problem which may arise when the test area is heated by pipes or electrical wires and cores must be taken from this area. Such installations must be carefully planned with respect to future core drilling locations. It is recommended to leave a few locations of size approximately 200 x 300 mm where there are no wires/pipes or where the latter are located deep enough in order not to be damaged by cores taken from the surface layer.

4.2. Sound absorption coefficient

The sound absorption coefficient (normal incidence) shall be measured by the impedance tube method using the procedure specified in ISO 10534:1994 - "Acoustics - Determination of sound absorption coefficient and impedance by a tube method."

Regarding test specimens, the same requirements shall be followed as regarding the residual voids content (see para. 4.1.). The sound absorption shall be measured in the range between 400 Hz and 800 Hz and in the range between 800 Hz and 1,600 Hz (at least at the centre frequencies of third octave bands) and the maximum values shall be identified for both of these frequency ranges. Then these values, for all test cores, shall be averaged to constitute the final result.

4.3. Volumetric macro texture measurement

For the purpose of this standard, texture depth measurements shall be made on at least 10 positions evenly spaced along the wheel tracks of the test strip and the average value taken to compare with the specified minimum texture depth. For the description of the procedure see standard ISO 10844:1994.

5. Stability in time and maintenance

5.1. Age influence

In common with any other surfaces, it is expected that the tyre/road noise level measured on the test surface may increase slightly during the first 6-12 months after construction.

The surface will achieve its required characteristics not earlier than four weeks after construction. The influence of age on the noise from trucks is generally less than that from cars.

The stability over time is determined mainly by the polishing and compaction by vehicles driving on the surface. It shall be periodically checked as stated in paragraph 2.5.

5.2. Maintenance of the surface

Loose debris or dust which could significantly reduce the effective texture depth must be removed from the surface. In countries with winter climates, salt is sometimes used for de-icing. Salt may alter the surface temporarily or even permanently in such a way as to increase noise and is therefore not recommended.

5.3. Repaving the test area

If it is necessary to repave the test track, it is usually unnecessary to repave more than the test strip (of 3 m width in Figure 1) where vehicles are driving, provided the test area outside the strip met the requirement of residual voids content or sound absorption when it was measured.

6. Documentation of the test surface and of tests performed on it

6.1. Documentation of the test surface

The following data shall be given in a document describing the test surface:

- 6.1.1. The location of the test track.
- 6.1.2. Type of binder, binder hardness, type of aggregate, maximum theoretical density of the concrete (D_R), thickness of the wearing course and grading curve determined from cores from the test track.
- 6.1.3. Method of compaction (e.g. type of roller, roller mass, number of passes).
- 6.1.4. Temperature of the mix, temperature of the ambient air and wind speed during laying of the surface.
- 6.1.5. Date when the surface was laid and contractor.
- 6.1.6. All or at least the latest test results, including:
 - 6.1.6.1. The residual voids content of each core.
 - 6.1.6.2. The locations in the test area from where the cores for voids measurements have been taken.
 - 6.1.6.3. The sound absorption coefficient of each core (if measured). Specify the results both for each core and each frequency range as well as the overall average.
 - 6.1.6.4. The locations in the test area from where the cores for absorption measurement have been taken.
 - 6.1.6.5. Texture depth, including the number of tests and standard deviation.
 - 6.1.6.6. The institution responsible for tests according to paragraphs 6.1.6.1. and 6.1.6.2. and the type of equipment used.
 - 6.1.6.7. Date of the test(s) and date when the cores were taken from the test track.
- 6.2. Documentation of vehicle noise tests conducted on the surface

In the document describing the vehicle noise test(s) it shall be stated whether all the requirements of this standard were fulfilled or not. Reference shall be given to a document according to paragraph 6.1. describing the results which verify this.

Annex 5

EXHAUST SYSTEM (SILENCER)

1. Fibrous absorbent material must be asbestos-free and may be used in the construction of silencers only if suitable devices ensure that the fibrous material is kept in place for the whole time that the silencer is being used and it meets the requirements of any one of paragraphs 1.1., 1.2. and 1.3.
 - 1.1. After removal of the fibrous material, the sound level must comply with the requirements of Annex 3 and the sound level limits of Annex 6.
 - 1.2. The fibrous absorbent material may not be placed in those parts of the silencer through which the exhaust gases pass and must comply with the following requirements:
 - 1.2.1. The material must be heated at a temperature of $650 \pm 5^{\circ}\text{C}$ for four hours in a furnace without reduction in every length, diameter or bulk density of the fibre.
 - 1.2.2. After heating at $650 \pm 5^{\circ}\text{C}$ for one hour in a furnace, at least 98 per cent of the material must be retained in a sieve of nominal aperture size $250 \mu\text{m}$ complying with

ISO Standard 3310/1 : 1990 when tested in accordance with
ISO Standard 2599 : 1983.
 - 1.2.3. The loss in weight of the material must not exceed 10.5 per cent after soaking for 24 hours at $90 \pm 5^{\circ}\text{C}$ in a synthetic condensate of the following composition:

1 N hydrobromic acid (HBr): 10 ml
1 N sulphuric acid (H_2SO_4): 10 ml
Distilled water to make up to 1,000 ml.

Note: The material must be washed in distilled water and dried for one hour at 105°C before weighing.
 - 1.3. Before the system is tested in accordance with Annex 3, it must be put into a normal state for road use by one of the following condition methods:
 - 1.3.1. CONDITIONING BY CONTINUOUS ROAD OPERATION
 - 1.3.1.1. According to the classes of motor cycles, the minimum distances to be completed during conditioning are:

Class of motor cycle according to Power-to-mass ratio index (PMR)	Distance (km)
Class I < 25	4,000
Class II > 25 ≤ 50	6,000
Class III > 50	8,000

1.3.1.2. 50 ± 10 per cent of this conditioning cycle consists of town driving and the remainder of long-distance runs at high speed; the continuous road cycle may be replaced by a corresponding test-track programme.

1.3.1.3. The two speed regimes must be alternated at least six times.

1.3.1.4. The complete test programme must include a minimum of 10 breaks of at least three hours' duration in order to reproduce the effects of cooling and condensation.

1.3.2. CONDITIONING BY PULSATION

1.3.2.1. The exhaust system or components thereof must be fitted to the motor cycle or to the engine. In the former case, the motor cycle must be mounted on a test bench.

The test apparatus, a detailed diagram of which is shown in Figure 1, is fitted at the outlet of the exhaust system. Any other apparatus providing equivalent results is acceptable.

1.3.2.2. The test equipment must be adjusted so that the flow of exhaust gases is alternatively interrupted and restored 2,500 times by a rapid-action valve.

1.3.2.3. The valve must open when the exhaust gas back-pressure, measured at least 100 mm downstream of the intake flange, reaches a value of between 0.35 and 0.40 bar. Should such a figure be unattainable because of the engine characteristics, the valve must open when the gas back-pressure reaches a level equivalent to 90 per cent of the maximum that can be measured before the engine stops. It must close when this pressure does not differ by more than 10 per cent from its stabilized value with the valve open.

1.3.2.4. The time-delay switch must be set for the duration of exhaust gases calculated on the basis of the requirements of paragraph 1.3.2.3.

1.3.2.5. Engine speed must be 75 per cent of the speed (S) at which the

engine develops maximum power.

1.3.2.6. The power indicated by the dynamometer must be 50 per cent of the full-throttle power measured at 75 per cent of engine speed (S).

1.3.2.7. Any drainage holes must be closed off during the test.

1.3.2.8. The entire test must be complete within 48 hours. If necessary, a cooling period must be allowed after each hour.

1.3.3. CONDITIONING ON A TEST BENCH

1.3.3.1. The exhaust system must be fitted to an engine representative of the type fitted to the motor cycle for which the exhaust system was designed, and mounted on a test bench.

1.3.3.2. Conditioning consists of the specific number of test bench cycles for each class of motor cycle for which the exhaust system was designed. The number of cycles for each class of motor cycle is:

Class of motor cycle according to Power-to-mass ratio index (PMR)	Number of cycles
Class I < 25	6
Class II > 25 < 50	9
Class III > 50	12

1.3.3.3. Each test-bench cycle must be followed by a break of at least six hours in order to reproduce the effects of cooling and condensation.

1.3.3.4. Each test-bench cycle consists of six phases. The engine conditions for and the duration of each phase are:

Phase	Conditions	Duration of phase	
		PMR \leq 50	PMR $>$ 50
		(minutes)	(minutes)
1	Idling	6	6
2	25 % load at 75 % S	40	50
3	50 % load at 75 % S	40	50
4	100 % load at 75 % S	30	10
5	50 % load at 100 % S	12	12
6	25 % load at 100 % S	22	22
	Total time	2.5 hours	2.5 hours

1.3.3.5. During this conditioning procedure, at the request of the manufacturer, the engine and the silencer may be cooled in order that the temperature recorded at a point not more than 100 mm from the exhaust gas outlet does not exceed that measured when the motor cycle is running at 110 km/h or 75 per cent S in top gear. The engine and/or motor cycle speeds are determined to within \pm 3 per cent.

Figure 1

TEST APPARATUS FOR CONDITIONING BY PULSATION

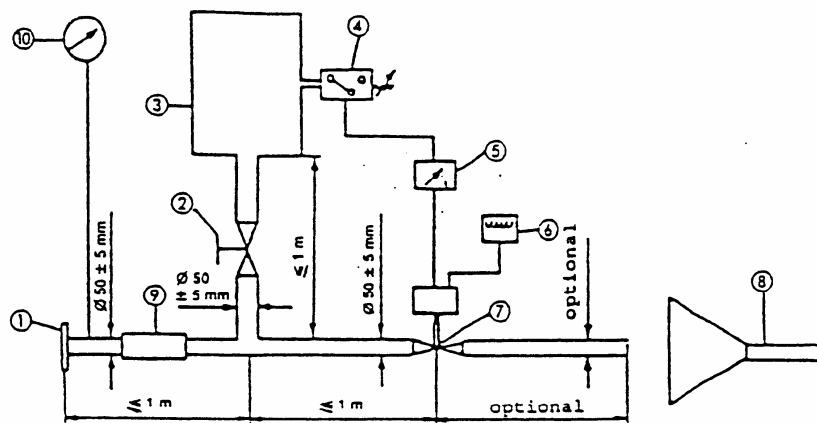

1. Inlet flange or sleeve for connection to the rear of the test exhaust system.
2. Hand-operated regulating valve.
3. Compensating reservoir with a maximum capacity of 40 litres.
4. Pressure switch with an operating range of 0.05 to 2.5 bar.
5. Time delay switch.
6. Impulse counter.
7. Quick response valve, such as exhaust brake valve 60 mm in diameter, operated by a pneumatic cylinder with an output of 120 N at 4 bar. The response time, both when opening and closing, must not exceed 0.5 seconds.
8. Exhaust gas evacuation.
9. Flexible pipe.
10. Pressure gauge.

Annex 6

MAXIMUM LIMITS OF SOUND LEVEL (NEW MOTORCYCLES)

Category of motorcycle	Power-to-mass ratio index (PMR)	Values expressed in dB(A)
First category	$PMR \leq 25$	[X]
Second category	$25 < PMR \leq 50$	[Y]
Third category	$PMR > 50$	[Z]

Annex 7

ADDITIONAL SOUND EMISSION PROVISIONS (NEW MOTOR CYCLES AND NEW EXHAUST OR SILENCING SYSTEMS)

1. Noise of the motorcycle in motion (measuring conditions and method for testing of the vehicle during verification by the administrative department which is granting the component type-approval).
 - 1.1. Limits: see section 1.6.
 - 1.2. Measuring instruments
See section 1.2 to annex 3.
 - 1.3. Acoustical environment, meteorological conditions and background noise
See section 1.3 to annex 3.
 - 1.4. Test procedures
See sections 1.5.1 to 1.5.2.3 to annex 3.
 - 1.4.1. Operating conditions
 - 1.4.1.1. General conditions

The path of the centerline of the vehicle shall follow line CC' as closely as possible throughout the entire test, from the approach to line AA' until the rear of the vehicle passes line BB' (see **Annex 4** - Figure 1). Any trailer that is not readily separable from the towing vehicle shall be ignored when considering the crossing of the line BB'. If the vehicle is fitted with more than two-wheel drive, test it in the drive selection that is intended for normal road use. If the vehicle is fitted with an auxiliary manual transmission or a multi-gear axle, the position used for normal urban driving shall be used. In all cases, the gear ratios for slow movements, parking or braking, shall be excluded.

- 1.4.1.2. Test speed and gear selection

The vehicle shall be tested at each of the following operating conditions:

- I.) $VAA' = 20 \text{ km/h}$
or $nAA' = 0.1 \cdot (s - n_{\text{idle}}) + n_{\text{idle}}$, if the corresponding $vAA' > 20 \text{ km/h}$

The selected gear shall be 4th. If stable driving cannot be achieved using 4th gear, 3rd gear shall be chosen. If stable driving cannot be achieved using 3rd gear, 2nd gear shall be chosen.

Note: nAA' shall be at least $0.1 \cdot (s - n_{\text{idle}}) + n_{\text{idle}}$

II.) $VPP' = 40 \text{ km/h (PMR} \leq 50) \text{ or } 50 \text{ km/h (PMR} > 50)$

The selected gear shall be [i].

III.) $V_{BB'}$ corresponding to $n_{BB'} = 3.4105 \cdot PMR - 0.3315 \cdot (s - n_{idle}) + n_{idle}$ ($PMR > 66$)

$(n_{BB'} = 0.85 \cdot (s - n_{idle}) + n_{idle})$ ($PMR \leq 66$)

Note: $V_{BB'}$ shall not exceed 80 km/h

The selected gear shall be 2nd.

If the 3rd gear satisfies requirements of $n_{BB'}$ and $V_{BB'}$, 3rd shall be used.

If the 4th gear satisfies requirements of $n_{BB'}$ and $V_{BB'}$, 4th shall be used.

where:

s is the rated engine speed in min⁻¹

n_{idle} is the idling speed in min⁻¹

$n_{AA'}$ is the engine speed at AA' in min⁻¹

$n_{BB'}$ is the engine speed at BB' in min⁻¹

$V_{AA'}$ is the vehicle speed at AA' in km/h

$V_{PP'}$ is the vehicle speed at PP' in km/h

$V_{BB'}$ is the vehicle speed at BB' in km/h

PMR = power-to-mass ratio index defined in section 2.6.4

$L_{wot,i}$ is the highest result of the full throttle acceleration tests in gear i as from section 1 to annex 3

n_i is the engine speed corresponding to $L_{wot,i}$.

The test speed shall be reached, when the reference point according to 2.6.6. passes line PP'. ~~The test speed shall be reduced by increments of 10% of $V_{PP'}$ in case the exit speed $V_{BB'}$ exceeds 75% of V_{max} .~~

When the front of the vehicle reaches AA', the acceleration control unit shall be fully engaged and held fully engaged until the rear of the vehicle reaches BB'. The acceleration control unit shall then be released. Pre-acceleration may be used if acceleration is delayed beyond AA'. The location of the start of the acceleration shall be reported.

The technical service may request the testing with one additional operating condition other than those above, provided that the conditions below are met:

- vehicle speed between 20 km/h ($v_{AA'}$) and 80 km/h ($v_{BB'}$)

- engine speed at AA' shall be at least $0.1 \cdot (s - n_{idle}) + n_{idle}$

- engine speeds at BB':

up to $0.85 \cdot (s - n_{idle}) + n_{idle}$ for $PMR \leq 66$,

up to $3,4105 \cdot PMR - 0,3315 \cdot (s - n_{idle}) + n_{idle}$, for $PMR > 66$

where:

s is the rated engine speed in min⁻¹,

n_{idle} is the idling speed in min⁻¹

$PMR = P_n$ in kW / (m_0 in kg + 75) * 1000

- 1.4.1.3. Automatic transmission, adaptive transmissions and transmissions with variable gear ratios tested with non-locked gear ratios

If the engine speeds for the tests described in section 1.4.1.2. do not differ significantly [by more than +/- X %] from those reached in the wide open throttle acceleration tests as from section 1 to annex 3, the Additional Sound Emissions Provisions shall not be applied.

- 1.4.1.4. Vehicles with $PMR < [50]$

The Additional Sound Emissions Provisions shall not be applied to vehicles with $PMR < [50]$

- 1.5. Measurement readings and reported values

- 1.5.1. General

At least **three** measurements for all test conditions shall be made on each side of the vehicle.

The maximum A-weighted sound pressure level indicated during each passage of the vehicle between AA' and BB' (**see Annex 4 - Figure 1**) shall be noted, to the first significant digit after the decimal place (e.g. XX,X). If a sound peak obviously out of character with the general sound pressure level is observed, that measurement shall be discarded.

The first **three** j th valid consecutive measurement results for any test condition, within 2,0 dB, allowing for the deletion of non-valid results, shall be used for the calculation of the final result.

The engine speed measurements at AA', BB', and PP' shall be noted and used in the calculations.

- 1.5.2. Data compilation, reported values and final results

For a given test condition, the results of each side of the vehicle shall be averaged separately.

The final value to be reported as the test result shall be the higher value of the two sides.

If the final result does not exceed the maximum permissible level for each given test condition, the limits laid down in section 1.6 will be deemed as being complied with.

- 1.6 Limits

The noise emission threshold curves are:

Upper curve $n > n_i$:

$$L_{\max}(n) = L_{wot,i} + a_1 \cdot (n - n_i) / 1000 + x \quad [\text{dB(A)}]$$

Lower curve $n < n_i$:

$$L_{\max}(n) = L_{wot,i} + a_2 \cdot (n - n_i) / 1000 + x \quad [\text{dB(A)}]$$

where:

$L_{\max}(n)$ is the limit value

$L_{wot,i}$ is (highest) result of the full throttle acceleration tests in gear i as from section 1 to annex 3

n is the engine speed in min^{-1}

n_i is the engine speed corresponding to $L_{wot,i}$

An example is shown in the following figure, assuming that $L_{wot,i}$ is 74 dB(A) at 2988 min^{-1} and n_{\max} is 4994 min^{-1} .

