



**Economic and Social
Council** Distr.
GENERAL

ECE/TRANS/WP.29/GRSP/2007/2
21 February 2007

Original: ENGLISH
ENGLISH AND FRENCH ONLY

ECONOMIC COMMISSION FOR EUROPE

INLAND TRANSPORT COMMITTEE

World Forum for Harmonization of Vehicle Regulations

Working Party on Passive Safety

Forty-first session

Geneva, 7-11 May 2007

Item 10.1. of the provisional agenda

REGULATION No. 29
(Cabs of commercial vehicles)

Proposal for draft amendments

Proposal for draft 03 series of amendments

Submitted by the expert from the International Organization of Motor Vehicle Manufacturers
(OICA)

The text reproduced below was prepared by the expert from OICA to insert into the Regulation new test methods for the different categories of vehicles. It is based on a document without a symbol (informal document No. GRSP-40-06), distributed during the fortieth session of GRSP (see report ECE/TRANS/WP.29/GRSP/40, paras. 31 and 34).

The modifications to the existing text of the Regulation are marked in **bold** characters or marked as strikethrough.

Note: This document is distributed to the Experts of the Working Party on Passive Safety (GRSP) only.

GE.07-

A. PROPOSAL

UNIFORM PROVISIONS CONCERNING THE APPROVAL OF VEHICLES
WITH REGARD TO THE PROTECTION OF THE OCCUPANTS OF THE CAB
OF A COMMERCIAL VEHICLE

1. SCOPE

This Regulation applies to vehicles of category N 1/ with regard to the protection of the occupants of the cab.

2. DEFINITIONS

For the purpose of this Regulation:

2.1. "approval of a vehicle" means the approval of a vehicle type pursuant to the requirements of this Regulation, with regard to the protection of the occupants of the cab of a commercial vehicle in the event of head-on impact ~~or~~ of overturning, ~~or of shifting of the load~~;

2.2. "vehicle type" means a category of power-driven vehicles which do not differ in such essential respects as:

2.2.1. the dimensions, shapes and materials of the components of the vehicle cab; or

2.2.2. the manner of attachment of the cab to the chassis frame;

2.3. "transverse plane" means a vertical plane perpendicular to the median longitudinal plane of the vehicle;

2.4. "longitudinal plane" means a plane parallel to the median longitudinal plane of the vehicle.

3. APPLICATION FOR APPROVAL

3.1. The application for approval of a vehicle type with regard to the protection of the occupants of the cab of a commercial vehicle shall be submitted by the vehicle manufacturer or by his duly accredited representative.

3.2. It shall be accompanied by drawings of the vehicle, showing the position of the cab on the vehicle and the manner of its attachment, and by sufficiently detailed drawings relating to the structure of the cab, all the said drawings being submitted in triplicate.

1/ As defined in Annex 7 to the Consolidated Resolution on the Construction of vehicles (R.E.3), document TRANS/WP.29/78/Rev.1/Amend.2, as last amended by Amendment 4.

4. APPROVAL

- 4.1. If the vehicle type submitted for approval pursuant to this Regulation meets the requirements of paragraph 5. hereof, approval of that vehicle type shall be granted.
- 4.2. An approval number shall be assigned to each type approved. Its first two digits (at present ~~02~~ **03** corresponding to the ~~02~~ **03** series of amendments) shall indicate the series of amendments incorporating the most recent major technical amendments made to the Regulation at the time of issue of the approval. The same Contracting Party may not assign the same number to another vehicle type within the meaning of paragraph 2.2. above.
- 4.3. Notice of approval or of extension or of refusal or of withdrawal of approval or production definitely discontinued of a vehicle type pursuant to this Regulation shall be communicated to the Parties to the Agreement which apply this Regulation by means of a form conforming to the model in annex 1 to this Regulation.
- 4.4. There shall be affixed, conspicuously and in a readily accessible place specified on the approval form, to every vehicle conforming to a vehicle type approved under this Regulation an international approval mark consisting of:
- 4.4.1. a circle surrounding the letter "E" followed by the distinguishing number of the country which had granted approval; 2/
- 4.4.2. the number of this Regulation, followed by the letter "R", a dash and the approval number to the right of the circle prescribed in paragraph 4.4.1.; ~~and~~
- 4.4.3. ~~an additional symbol separated from the number of this Regulation by a vertical line and consisting of the letter "C" if the cab meets the requirements of test C.~~

2/ 1 for Germany, 2 for France, 3 for Italy, 4 for the Netherlands, 5 for Sweden, 6 for Belgium, 7 for Hungary, 8 for the Czech Republic, 9 for Spain, 10 for Serbia and Montenegro, 11 for the United Kingdom, 12 for Austria, 13 for Luxembourg, 14 for Switzerland, 15 (vacant), 16 for Norway, 17 for Finland, 18 for Denmark, 19 for Romania, 20 for Poland, 21 for Portugal, 22 for the Russian Federation, 23 for Greece, 24 for Ireland, 25 for Croatia, 26 for Slovenia, 27 for Slovakia, 28 for Belarus, 29 for Estonia, 30 (vacant), 31 for Bosnia and Herzegovina, 32 for Latvia, 33 (vacant), 34 for Bulgaria, 35 (vacant), 36 for Lithuania, 37 for Turkey, 38 (vacant), 39 for Azerbaijan, 40 for The former Yugoslav Republic of Macedonia, 41 (vacant), 42 for the European Community (Approvals are granted by its Member States using their respective ECE symbol), 43 for Japan, 44 (vacant), 45 for Australia, 46 for Ukraine, 47 for South Africa, 48 for New Zealand, 49 for Cyprus, 50 for Malta, 51 for the Republic of Korea, 52 for Malaysia and 53 for Thailand. Subsequent numbers shall be assigned to other countries in the chronological order in which they ratify or accede to the Agreement Concerning the Adoption of Uniform Technical Prescriptions for Wheeled Vehicles, Equipment and Parts which can be Fitted and/or be Used on Wheeled Vehicles and the Conditions for Reciprocal Recognition of Approvals Granted on the Basis of these Prescriptions, and the numbers thus assigned shall be communicated by the Secretary-General of the United Nations to the Contracting Parties to the Agreement.

- 4.5. If the vehicle conforms to a vehicle type approved, under one or more other Regulations annexed to the Agreement, in the country which has granted approval under this Regulation, the symbol prescribed in paragraph 4.4.1. need not be repeated; in such a case the additional numbers and symbols of all the Regulations under which approval has been granted in the country which has granted approval under this Regulation shall be placed in vertical columns to the right of the symbol prescribed in paragraph 4.4.1.
- 4.6. The approval mark shall be clearly legible and be indelible.
- 4.7. The approval mark shall be placed close to or on the vehicle data plate affixed by the manufacturer.
- 4.8. Annex 2 to this Regulation gives examples of arrangements of approval marks.

5. REQUIREMENTS

- 5.1. The cab of the vehicle shall be so designed and so attached to the vehicle as to eliminate to the greatest possible extent the risk of injury to the occupants in the event of an accident.

- 5.2. ~~It shall be subjected, at the manufacturer's choice, either to all the tests specified in annex 3 to this Regulation or only to tests A and B. However a vehicle type which has been approved according to Regulation No. 33 may be considered to have satisfied the requirements on frontal impact (test A).~~
One, two or three cabs, at the manufacturer's choice, shall be used for the ~~this~~ purpose **of demonstrating compliance with paragraph 5.1. above, on the basis of the requirements of paragraphs 5.3. or 5.4. below.**

- 5.3. **For vehicles of category N₁ and of category N₂ with a GVM not exceeding 7.5 t, the requirements are those of Regulation No. 29 in its series 02 of amendments. A vehicle type in these categories which has been approved according to Regulation No. 33 or to Regulation No. 94 shall be considered to have satisfied the requirements on frontal impact of this Regulation in its series 02 of amendments.**

- 5.4. **For vehicles of category N₂ with a GVM exceeding 7.5 t and of category N₃, the cab shall meet the following requirements:**

5.4.1. **Front impact test (test A)**

The frontal impact strength test is intended to evaluate the resistance of a cab in frontal impact accident.

Only cabs intended for "cab over engine vehicles" need to be tested with test A. The test procedure is described in Annex 3 to this Regulation.

5.4.2. A-pillar Impact Test (Test B)

The A-Pillar test is intended to evaluate the resistance of a cab in a 90° rollover accident with subsequent impact.

The test procedure is described in Annex 4 to this Regulation.

5.4.3. Roof Structural Test (Test C)

The cab roof strength test is intended to evaluate the resistance of a cab in a 180° rollover accident.

This test consists of two parts. The first one is an impact on the side of the cab; it is described in Annex 5, paragraph 3.1. to this Regulation. The second one is a quasi-static roof loading; it is described in Annex 5, paragraph 3.2. to this Regulation. Both parts of the test C shall be carried out on the same cab.

5.5. Survival space required after the test or tests

5.5.1. After undergoing each of the tests referred to in paragraph 5.4. above, the cab of the vehicle shall exhibit a survival space allowing accommodation of **an un-instrumented 50th percentile Hybrid III dummy as defined in Regulation No. 94, the manikin defined in Annex 3, Appendix 2,** on the seat, when the latter is in its median position, without contact between the **dummy manikin** and non-resilient parts **with a Shore-Hardness of 50 or more.** ~~To facilitate installation, the manikin may be inserted in dismantled form and assembled in the cab. For this purpose, the seat shall be adjusted to its most rearward position and the manikin completely assembled and so placed that its H point coincides with the R point. The seat shall then be moved forward to its median position for the assessment of the survival space.~~

5.5.2. The space so defined shall be verified for every seat provided by the manufacturer.

5.6. Other conditions

5.6.1. During the tests the components by which the cab is secured to the chassis frame may be distorted or broken, provided that the cab remains attached to the chassis frame.

5.6.2. **The steering wheel and seat position must be in the normal position of use, in accordance with the instructions of the manufacturer.**

5.6.3. None of the doors shall open during the tests **and/or separate from the vehicle,** but the doors shall not be required to open after testing.

5.7. ~~None of the required tests B and C need not be~~ needs to be carried out if the manufacturer can show by calculations of the strength of the component parts of the cab or by other means that the ~~roof or rear wall cab~~ will not undergo deformation

dangerous to the occupants (penetration into the survival space) if subjected to the conditions of ~~the tests B and C.~~

6. MODIFICATIONS AND EXTENSION OF APPROVAL OF THE VEHICLE TYPE

6.1. Every modification of the vehicle type shall be notified to the administrative department which approved the vehicle type. That department may then either:

6.1.1. consider that the modifications made are unlikely to have an appreciable adverse effect, and that in any case the vehicle still meets the requirements; or

6.1.2. require a further test report from the technical service responsible for conducting the tests.

6.2. Confirmation or refusal of approval, specifying the alterations, shall be communicated by the procedure specified in paragraph 4.3. above to the Contracting Parties to the Agreement which apply this Regulation.

6.3. The competent authority issuing the extension of approval shall assign a series number for such an extension and inform thereof the other Parties to the 1958 Agreement applying this Regulation by means of a communication form conforming to the model in Annex 1 to this Regulation.

7. CONFORMITY OF PRODUCTION

The conformity of production procedures shall comply with those set out in the Agreement, Appendix 2 (E/ECE/324-E/ECE/TRANS/505/Rev.2), with the following requirements:

7.1. Every vehicle bearing an approval mark as prescribed under this Regulation shall conform to the vehicle type approved as regards features capable of affecting the characteristics of the cab.

7.2. In order to verify conformity as prescribed in paragraph 7.1. above, serially-produced vehicles bearing the approval mark required by this Regulation may be subjected to random checks.

7.3. As a general rule, the checks aforesaid shall be confined to the taking of measurements. However, the vehicles shall if necessary be subjected to the tests described in Annex 3 to this Regulation.

8. PENALTIES FOR NON-CONFORMITY OF PRODUCTION

8.1. The approval granted in respect of a vehicle type pursuant to this Regulation may be withdrawn if the requirement laid down in paragraph 7.1. above is not complied with or if the cab fails to pass the checks prescribed in paragraphs 7.2. and 7.3. above.

- 8.2. If a Party to the Agreement which applies this Regulation withdraws an approval it has previously granted, it shall forthwith notify the other Contracting Parties applying this Regulation by means of a communication form conforming to the model in Annex 1 to this Regulation.

9. PRODUCTION DEFINITELY DISCONTINUED

If the holder of the approval completely ceases to manufacture a vehicle type approved in accordance with this Regulation, he shall so inform the authority which granted the approval. Upon receiving the relevant communication that authority shall inform thereof the other Parties to the 1958 Agreement which apply this Regulation by means of a communication form conforming to the model in Annex 1 to this Regulation.

10. TRANSITIONAL PROVISIONS

- 10.1. As from the official date of entry into force of the 02 series of amendments, no Contracting Party applying this Regulation shall refuse to grant ECE approval under this Regulation as modified by 02 series of amendments.

- 10.2. As from 1 October 2002 Contracting Parties applying this Regulation shall grant ECE approvals only if the requirements of this Regulation, as amended by 02 series of amendments are satisfied.

- 10.3. As from 1 October 2006 Contracting Parties applying this Regulation may refuse to recognise approvals which were not granted in accordance with the 02 series of amendments to this Regulation.

- 10.4 As from the official date of entry into force of the 03 series of amendments, no Contracting Party applying this Regulation shall refuse to grant ECE approval under this Regulation to new types of cabs complying with this Regulation as modified by the 03 series of amendments.**

- 10.5 As from 6 years after the date referred to in paragraph 10.4., Contracting Parties applying this Regulation shall grant ECE approvals under this Regulation to new types of cabs only if the requirements of this Regulation, as amended by the 03 series of amendments, are satisfied.**

- 10.6 However, no Contracting Party applying this Regulation shall refuse to grant extensions of approvals to cabs approved in accordance with the 02 series of amendments to this Regulation.**

11. NAMES AND ADDRESSES OF TECHNICAL SERVICES CONDUCTING APPROVAL TESTS, AND OF ADMINISTRATIVE DEPARTMENTS

The Parties to the Agreement which apply this Regulation shall communicate to the Secretariat of the United Nations the names and addresses of the technical services

conducting approval tests and of the administrative departments which grant approval and to which forms certifying approval or refusal or withdrawal of approval, issued in other countries, are to be sent.

Annex 1

COMMUNICATION

(maximum format: A4 (210 x 297 mm))



Issued by: Name of administration

.....
.....
.....

concerning: 2/ APPROVAL GRANTED
APPROVAL EXTENDED
APPROVAL REFUSED
APPROVAL WITHDRAWN
PRODUCTION DEFINITELY DISCONTINUED

of a vehicle type with regard to the protection of the occupants of the cab of a commercial vehicle pursuant to Regulation No. 29.

Approval No:

Extension No:

1. Trade name or mark of the vehicle
2. Vehicle type
3. Manufacturer's name and address
4. If applicable, name and address of manufacturer's representative
5. Brief description of the cab's design and method of attachment
6. Vehicle submitted for approval on
7. Technical service responsible for conducting approval tests

1/ Distinguishing number of the country which has granted/extended/refused/withdrawn approval (see approval provisions in the Regulation).

2/ Strike out what does not apply.

8. Date of test report issued by that service
9. Number of test report issued by that service
- ~~10. Tests passed by cab: A / B / C /~~
10. Approval granted/extended/refused/withdrawn 2/
11. Position of approval mark on the vehicle
12. Place
13. Date
14. Signature

The list of documents deposited with the Administrative Service which has granted approval is annexed to this communication and may be obtained on request.

2/ Strike out what does not apply

Annex 2

ARRANGEMENTS OF APPROVAL MARKS

Model A

(See paragraph 4.4. of this Regulation)

[Note: marking picture not reproduced here]

The above approval mark affixed to a vehicle shows the vehicle type concerned has with regard to the protection of the occupants of the cab of a commercial vehicle, been approved in the Netherlands (E 4), under the number **032439** ~~022439~~ ~~and that the cab of the vehicle meets the requirements of test C.~~ The first two digits of the approval number indicate the Regulation No. 29 already included the **03** ~~02~~ series of amendments when the approval was given.

Model B

(See paragraph 4.5. of this Regulation)

[Note: marking picture not reproduced here]

The above approval mark affixed to a vehicle shows that the vehicle type concerned has been approved in the Netherlands (E 4) pursuant to Regulations No. 29 and 24. 1/ (In the case of the latter Regulation the corrected absorption coefficient is 1.30 m^{-1}). ~~The cab of the vehicle does not meet the requirements of test C.~~ The approval numbers indicate that on the dates on which these approvals were granted Regulations Nos. 29 and 24 included the **03** ~~02~~ series of amendments.

1/ The second number is given merely as an example

Annex 3

TEST PROCEDURE FOR TEST A - FRONTAL IMPACT

1. Doors

Before the test the doors of the cab shall be closed but not locked.

2. Engine

For test A the engine, or a model equivalent thereto in mass, dimensions and mounting, shall be fitted to the vehicle.

3. Anchorage of the cab

~~For test A, the~~ The cab shall be mounted on a vehicle. ~~For tests B and C, the cab shall at the manufacturer's choice be mounted either on a vehicle or on a separate frame. The vehicle or frame shall be secured in the manner prescribed in appendix 1 to this annex.~~

4. Front impact test

4.1. Description of the swing-bob

4.1.1. The swing-bob shall be made of steel and its mass shall be evenly distributed; its mass shall be **at least** 1,500 ~~±250~~ kg. Its striking surface, rectangular and flat, shall be 2500 mm wide and 800 mm high. Its edges shall be rounded to a radius of curvature of not less than ~~±5~~ **15** mm.

4.1.2. The swing-bob assembly shall be of rigid construction. The swing-bob shall be freely suspended by two beams rigidly attached to it and spaced not less than 1,000 mm apart. The beams shall be of "I" section with a web height of not less than 100 mm or shall be of a section having at least an equivalent moment of inertia. The beams shall be not less than 3,500 mm long from the axis of suspension to the geometric centre of the bob. **As an alternative, other suspension systems may be used, provided any unwanted pendulum rotation is avoided.**

4.1.3. The swing-bob shall be so positioned that in the vertical position

4.1.3.1. its striking face is in contact with the foremost part of the vehicle;

4.1.3.2. its centre of gravity is 50 ~~+5/-0~~ mm below the R point of the driver's seat, and

4.1.3.3. its centre of gravity is in the median longitudinal plane of the vehicle.

4.1.4. The swing-bob shall strike the cab at the front in the direction towards the rear of the cab. The direction of impact shall be horizontal and shall be parallel to the median

longitudinal plane of the vehicle. The impact energy shall be **50 kJ** ~~3,000 mkgf for vehicles of a permissible maximum mass up to 7,000 kg and 4,500 mkgf for vehicles for which the permissible maximum mass exceeds this value.~~

5. ~~Roof strength (test B)~~

~~The roof of the cab shall withstand a static load corresponding to the maximum mass authorized for the front axle or axles of the vehicle, subject to a maximum of 10 tonnes. This load shall be distributed uniformly over all the bearing members of the roof structure of the driver's cab or compartment by means of a suitably shaped rigid former.~~

6. ~~Rear wall strength (test C)~~

~~The rear wall of the cab shall be capable of withstanding a static load of 200 kgf per tonne of permissible useful load. This load shall be applied by means of a rigid barrier perpendicular to the longitudinal median axis of the vehicle, covering at least the whole of the cab rear wall situated above the chassis frame, and moving parallel to that axis.~~

Annex 3 - Appendix 1

INSTRUCTIONS FOR SECURING VEHICLES TO THE TEST BED

1. Frontal impact

Test A shall be applied to a cab mounted on the vehicle in the following way (see figure 1 below).

1.1. Anchoring chains or ropes

Each anchoring chain or rope shall be of steel and shall be capable of withstanding a tractive load of at least 10 tons.

1.2. Blocking of the chassis frame

The longitudinal members of the chassis frame shall be supported on wooden blocks across their full width and over a length of not less than 150 mm. The front edges of the blocks must not be situated forward of the rearmost point of the cab, nor rearward of the mid-point of the wheel base. At the manufacturer's request the chassis frame shall be set in the attitude it takes up when loaded.

1.3. Longitudinal attachment

Rearward movement of the chassis frame shall be limited by chains or ropes A attached to the front of the chassis frame symmetrically in relation to its longitudinal axis, the points of attachment being not less than 600 mm apart. The chains or ropes shall when tensioned form a downward angle of not more than 25° with the horizontal and their projection on a horizontal plane shall form an angle of not more than 10° with the longitudinal axis of the vehicle. The chains or ropes may cross one another.

1.4. Lateral attachment

Lateral movement shall be limited by chains or ropes B attached to the chassis frame symmetrically in relation to its longitudinal axis. The points of attachment to the chassis shall be not more than 5 m and not less than 3 m from the front of the vehicle. The chains or ropes shall when tensioned form a downward angle of not more than 20° with the horizontal and their projection on a horizontal plane shall form an angle of not less than 25° and not more than 45° with the longitudinal axis of the vehicle.

1.5. Tensioning of chains or ropes and rear attachment

The chain or rope C shall to begin with be placed under a load of approximately **1 kN** ~~100 kgf~~. All slack in the four chains or ropes A and B shall then be taken up and chain or rope C shall be subjected to a tensile stress of not less than **10 kN** ~~1,000 kgf~~. The angle of chain or rope C with the horizontal shall not

exceed 15°. A vertical blocking force of not less than **500 N** ~~50 kgf~~ shall be applied at point D between the chassis frame and the ground.

1.6. Equivalent mounting

At the request of the manufacturer the test may be carried out with the cab mounted on a special frame, on condition that this method of mounting is shown to be equivalent to mounting on the vehicle.

~~2. Roof strength~~

~~2.1 Cab mounted on the vehicle~~

~~Measures shall be taken to ensure that the vehicle does not shift appreciably during the test. For this purpose the hand brake shall be applied, a gear engaged and the front wheels wedged with chocks. Deformation of the various components of the suspension (springs, tires, etc.) shall be eliminated by means of rigid members.~~

~~2.2 Cab mounted on a frame~~

~~Measures shall be taken to ensure that the frame does not shift appreciably during the test.~~

~~3. Strength of rear wall~~

~~3.1. Cab mounted on the vehicle~~

~~Measures shall be taken to ensure that the vehicle does not shift appreciably during the test. For this purpose the hand brake shall be applied, a gear engaged and the front wheels wedged with chocks.~~

~~3.2. Cab mounted on a frame~~

~~Measures shall be taken to ensure that the frame does not shift appreciably during the test.~~

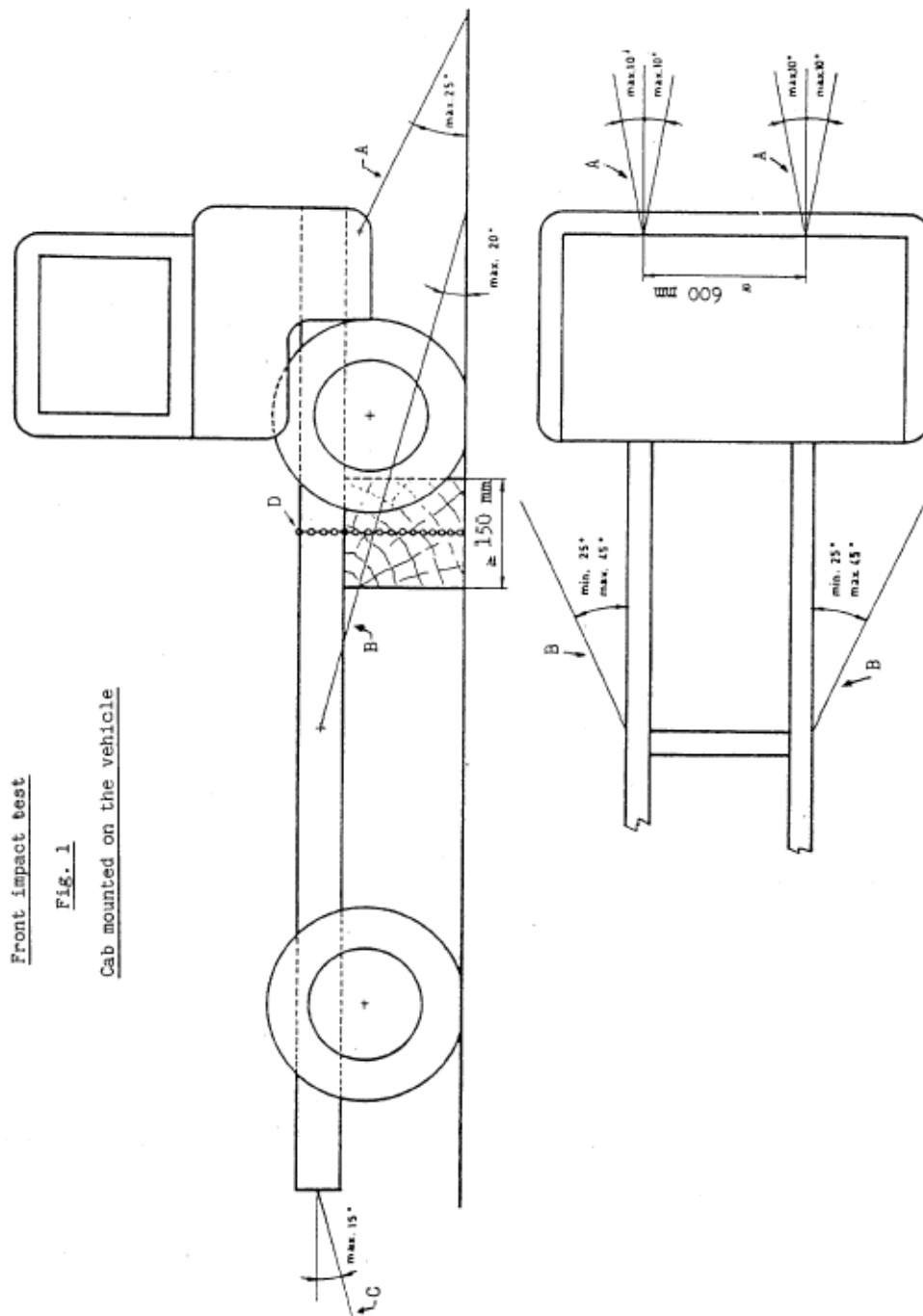

Annex 3 Appendix 2

~~MANIKIN TO BE USED TO VERIFY THE SURVIVAL SPACE~~

~~(Fiftieth percentile male body)~~

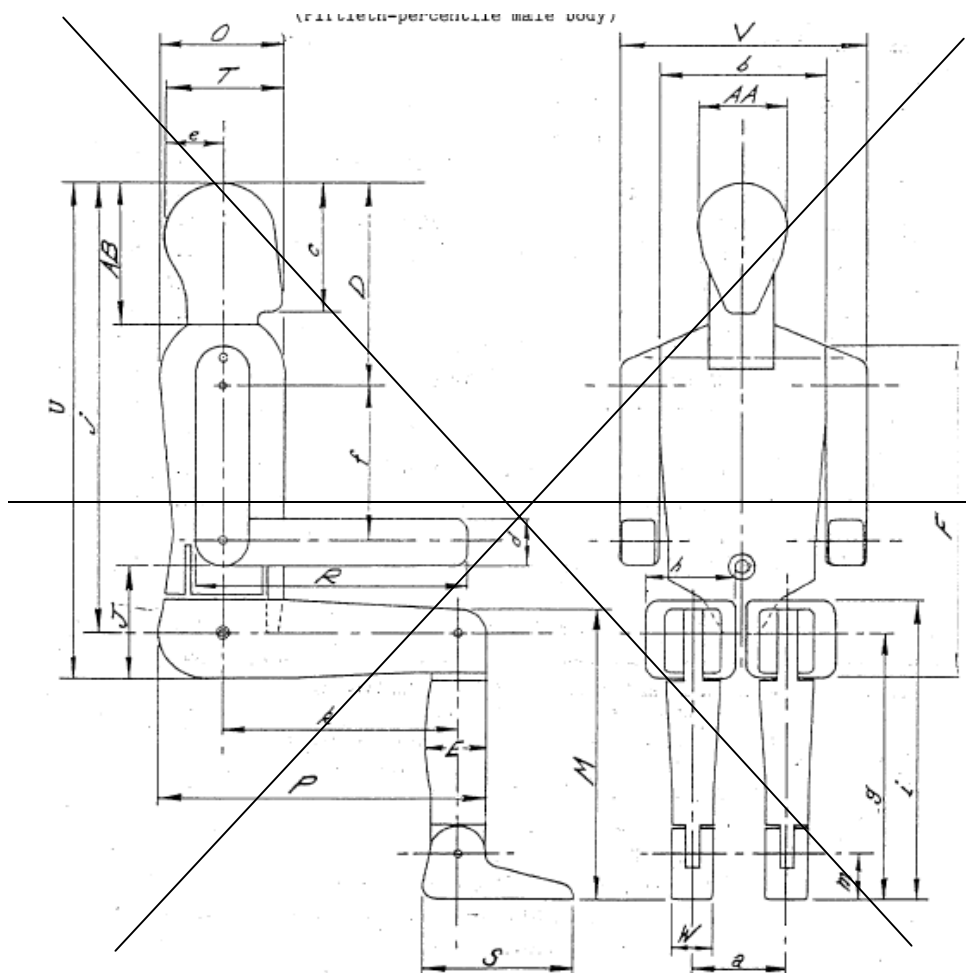

Annex 4

TEST PROCEDURE FOR TEST B - 90° ROLLOVER (IMPACT ON THE A-PILLAR)

1. Doors

Before the test the doors of the cab shall be closed but not locked.

2. Anchorage of the cab

The cab shall, at the manufacturer's choice, be mounted either on a vehicle or on a separate frame. The vehicle or frame shall be secured in the manner prescribed in Annex 3, Appendix 1.

3. A-pillar impact test (test B)

3.1. Pendulum

The pendulum shall be of bifilar type and made of steel and its mass shall be evenly distributed; its mass shall be at least 1,000 kg. Its striking surface should be flat and sufficient to insure that the impacted area of the cab is within the boundaries of the plate. Its edges shall be rounded to a radius of curvature of not less than 15 mm.

3.2. Impact test

The striking surface of the pendulum is inclined 45° to vertical at impact and is directed at an angle of 15° to the vehicle's longitudinal direction.

The impact energy shall be 30 kJ.

The pendulum is pulled back to a height determined to obtain the target impact energy and released to swing into the upper edge on the driver's side of the cab.

Annex 5

TEST PROCEDURE FOR TEST C - 180° ROLLOVER

1. Doors

Before the test the doors of the cab shall be closed but not locked.

3. Anchorage of the cab

The cab shall at the manufacturer's choice be mounted either on an actual or on simulated frame rails with its standard cab mounts.

4. Rollover test (test C)

The cab roof strength test is intended to evaluate the resistance of a heavy-truck cab in a 180° rollover accident. The loading is divided into two phases, a dynamic pre-load that simulates the side loading on the upper cab as the vehicle rolls past 90°, and a quasi-static roof loading that simulates the loading on the cab when the vehicle is inverted. Both phases are conducted on the same cab. The loadings are applied to the cab with rigid flat platens.

3.1. Dynamic pre-loading

During the pre-loading phase, the upper side of the cab is hit by a rigid platen with an angle of 20° to the vertical and an energy level of 17.6 kJ. Either the plate or the cab may be moved. The direction of the impact is perpendicular to the longitudinal axis of the cab.

3.2. Roof loading

During the roof loading phase, a quasi-static force is applied to the roof by means of a rigid flat platen to simulate ground contacting the roof of the cab. The platen shall be parallel to the x-y plane of the chassis and shall move parallel to the vertical axis of the chassis. The platen shall be sufficiently large and positioned such that the cab will contact only the interior of the platen, not the edges.

A linear bearing system shall be included between the platen and its supporting structure to allow for lateral motion of the cab roof away from the side that was impacted in the pre-load phase.

The roof of the cab shall withstand a static load corresponding to the maximum mass authorised for the front axle or axles of the vehicle, subject to a maximum of 98 kN. This load shall be distributed uniformly over all the bearing members of the roof structure of the driver's cab or compartment by means of a suitably-shaped rigid former.

Annex 6

PROCEDURE FOR DETERMINING THE "H" POINT AND THE ACTUAL TORSO ANGLE FOR SEATING POSITIONS IN MOTOR VEHICLES

1. PURPOSE

The procedure described in this annex is used to establish the "H" point location and the actual torso angle for one or several seating positions in a motor vehicle and to verify the relationship of measured data to design specifications given by the vehicle manufacturer. ^{1/}

2. DEFINITIONS

For the purposes of this annex:

- 2.1. "Reference data" means one or several of the following characteristics of a seating position:
 - 2.1.1. the "H" point and the "R" point and their relationship,
 - 2.1.2. the actual torso angle and the design torso angle and their relationship.
- 2.2. "Three-dimensional 'H' point machine" (3-D H machine) means the device used for the determination of "H" points and actual torso angles. This device is described in appendix 1 to this annex;
- 2.3. "'H' Point" means the pivot centre of the torso and the thigh of the 3-D H machine installed in the vehicle seat in accordance with paragraph 4. below. The "H", point is located in the centre of the centreline of the device which is between the "H" point sight buttons on either side of the 3-D H machine. The "H" point corresponds theoretically to the "R" point (for tolerances see paragraph 3.2.2. below). Once determined in accordance with the procedure described in paragraph 4., the "H" point is considered fixed in relation to the seat-cushion structure and to move with it when the seat is adjusted;
- 2.4. "'R' point" or "seating reference point" means a design point defined by the vehicle manufacturer for each seating position and established with respect to the three-dimensional reference system;
- 2.5. "Torso-line" means the centreline of the probe of the 3-D H machine with the probe in the fully rearward position;

^{1/} In any seating position other than front seats where the "H" point cannot be determined using the "Three-dimensional 'H' point machine" or procedures, the "R" point indicated by the manufacturer may be taken as a reference at the discretion of the competent authority.

- 2.6. "Actual torso angle" means the angle measured between a vertical line through the "H" point the torso line using the back angle quadrant on the 3-D H machine. The actual torso angle corresponds theoretically to the design torso angle (for tolerances see paragraph 3.2.2. below):
- 2.7. "Design torso angle" means the angle measured between a vertical line through the "R" point and the torso line in a position which corresponds to the design position of the seat-back established by the vehicle manufacturer;
- 2.8. "Centreplane of occupant" (C/LO) means the median plane of the 3-D H machine positioned in each designated seating position; it is represented by the co-ordinate of the "H" point on the "Y" axis. For individual seats, the centreplane of the seat coincides with the centreplane of the occupant. For other seats, the centreplane of the occupant is specified by the manufacturer;
- 2.9. "Three-dimensional reference system" means a system as described in appendix 2 to this annex;
- 2.10. "Fiducial marks" are physical points (holes, surfaces, marks or indentations) on the vehicle body as defined by the manufacturer;
- 2.11. "Vehicle measuring attitude" means the position of the vehicle as defined by the co-ordinates of fiducial marks in the three-dimensional reference system.

3. REQUIREMENTS

4.1. Data presentation

For each seating position where reference data are required in order to demonstrate compliance with the provisions of the present Regulation, all or an appropriate selection of the following data shall be presented in the form indicated in appendix 3 to this annex:

- 3.1.1. the co-ordinates of the "R" point relative to the three-dimensional reference system;
- 3.1.2. the design torso angle;
- 3.1.3. all indications necessary to adjust the seat (if it is adjustable) to the measuring position set out in paragraph 4.3. below.

3.2. Relationship between measured data and design specifications

- 3.2.1. The co-ordinates of the "H" point and the value of the actual torso angle obtained by the procedure set out in paragraph 4. below shall be compared, respectively, with the co-ordinates of the "R" point and the value of the design torso angle indicated by the vehicle manufacturer.

- 3.2.2. The relative positions of the "R" point and the "H" point and the relationship between the design torso angle and the actual torso angle shall be considered satisfactory for the seating position in question if the "H" point, as defined by its co-ordinates, lies within a square of 50 mm side length with horizontal and vertical sides whose diagonals intersect at the "R" point, and if the actual torso angle is within 5° of the design torso angle.
- 3.2.3. If these conditions are met, the "R" point and the design torso angle, shall be used to demonstrate compliance with the provisions of this Regulation.
- 3.2.4. If the "H" point or the actual torso angle does not satisfy the requirements of paragraph 3.2.2. above, the "H" point and the actual torso angle shall be determined twice more (three times in all). If the results of two of these three operations satisfy the requirements, the conditions of paragraph 3.2.3. above shall apply.
- 3.2.5. If the results of at least two of the three operations described in paragraph 3.2.4. above do not satisfy the requirements of paragraph 3.2.2. above, or if the verification cannot take place because the vehicle manufacturer has failed to supply information regarding the position of the "R" point or regarding the design torso angle, the centroid of the three measured points or the average of the three measured angles shall be used and be regarded as applicable in all cases where the "R" point or the design torso angle is referred to in this Regulation.

4. PROCEDURE FOR "H" POINT AND ACTUAL TORSO ANGLE DETERMINATION

- 4.1. The vehicle shall be preconditioned at the manufacturer's discretion, at a temperature of $20 \pm 10^{\circ}$ C to ensure that the seat material reached room temperature. If the seat to be checked has never been sat upon, a 70 to 80 kg person or device shall sit on the seat twice for one minute to flex the cushion and back. At the manufacturer's request, all seat assemblies shall remain unloaded for a minimum period of 30 min prior to installation of the 3-D H machine.
- 4.2. The vehicle shall be at the measuring attitude defined in paragraph 2.11. above.
- 4.3. The seat, if it is adjustable, shall be adjusted first to the rearmost normal driving or riding position, as indicated by the vehicle manufacturer, taking into consideration only the longitudinal adjustment of the seat, excluding seat travel used for purposes other than normal driving or riding positions. Where other modes of seat adjustment exist (vertical, angular, seat-back, etc.) these will then be adjusted to the position specified by the vehicle manufacturer. For suspension seats, the vertical position shall be rigidly fixed corresponding to a normal driving position as specified by the manufacturer.

- 4.4. The area of the seating position contacted by the 3-D H machine shall be covered by a muslin cotton, of sufficient size and appropriate texture, described as a plain cotton fabric having 18.9 threads per cm² and weighing 0.228 kg/m² or knitted or non-woven fabric having equivalent characteristics. If test is run on a seat outside the vehicle, the floor on which the seat is placed shall have the same essential characteristics 2/ as the floor of the vehicle in which the seat is intended to be used.
- 4.5. Place the seat and back assembly of the 3-D H machine so that the centreplane of the occupant (C/LO) coincides with the centreplane of the 3-D H machine. At the manufacturer's request, the 3-D H machine may be moved inboard with respect to the C/LO if the 3-D H machine is located so far outboard that the seat edge will not permit levelling of the 3-D H machine.
- 4.6. Attach the foot and lower leg assemblies to the seat pan assembly, either individually or by using the T-bar and lower leg assembly. A line through the "H" point sight buttons shall be parallel to the ground and perpendicular to the longitudinal centreplane of the seat.
- 4.7. Adjust the feet and leg positions of the 3-D H machine as follows:
- 4.7.1. Designated seating position: driver and outside front passenger
- 4.7.1.1. Both feet and leg assemblies shall be moved forward in such a way that the feet take up natural positions on the floor, between the operating pedals if necessary. Where possible the left foot shall be located approximately the same distance to the left of the centreplane of the 3-D H machine as the right foot is to the right. The spirit level verifying the transverse orientation of the 3-D H machine is brought to the horizontal by readjustment of the seat pan if necessary, or by adjusting the leg and foot assemblies towards the rear. The line passing through the "H" point sight buttons shall be maintained perpendicular to the longitudinal centreplane of the seat.
- 4.7.1.2. If the left leg cannot be kept parallel to the right leg and the left foot cannot be supported by the structure, move the left foot until it is supported. The alignment of the sight buttons shall be maintained.
- 4.7.2. Designated seating position: outboard rear
- For rear seats or auxiliary seats, the legs are located as specified by the manufacturer. If the feet then rest on parts of the floor which are at different levels, the foot which first comes into contact with the front seat shall serve as a reference and the other foot shall be so arranged that the spirit level giving the transverse orientation of the seat of the device indicates the horizontal.

2/ Tilt angle, height difference with a seat mounting, surface texture, etc.

4.7.3. Other designated seating positions:

The general procedure indicated in paragraph 4.7.1. above shall be followed except that the feet shall be placed as specified by the vehicle manufacturer.

4.8. Apply lower leg and thigh weights and level the 3-D H machine.

4.9. Tilt the back pan forward against the forward stop and draw the 3-D H machine away from the seat-back using the T-bar. Reposition the 3-D H machine on the seat by one of the following methods:

4.9.1. If the 3-D H machine tends to slide rearward, use the following procedure. Allow the 3-D H machine to slide rearward until a forward horizontal restraining load on the T-bar is no longer required i.e. until the seat pan contacts the seat-back. If necessary, reposition the lower leg.

4.9.2. If the 3-D H machine does not tend to slide rearward, use the following procedure. Slide the 3-D H machine rearwards by applying a horizontal rearward load to the T-bar until the seat pan contacts the seat-back (see figure 2 of Appendix 1 to this annex).

4.10. Apply a 100 ± 10 N load to the back and pan assembly of the 3-D H machine at the intersection of the hip angle quadrant and the T-bar housing. The direction of load application shall be maintained along a line passing by the above intersection to a point just above the thigh bar housing (see figure 2 of Appendix 1 to this annex). Then carefully return the back pan to the seat-back. Care must be exercised throughout the remainder of the procedure to prevent 3-D H machine from sliding forward.

4.11. Install the right and left buttock weights and then, alternately, the eight torso weights. Maintain the 3-D H machine level.

4.12. Tilt the back pan forward to release the tension on the seat-back. Rock the 3-D H machine from side to side through 10° arc (5° to each side of the vertical centreplane) for three complete cycles to release any accumulated friction between the 3-D H machine and the seat.

During the rocking action, the T-bar of the 3-D H machine may tend to diverge from the specified horizontal and vertical alignment. The T-bar must therefore be restrained by applying an appropriate lateral load during the rocking motions. Care shall be exercised in holding the T-bar and rocking the 3-D H machine to ensure that no inadvertent exterior loads are applied in a vertical or fore and aft direction.

The feet of the 3-D H machine are not to be restrained or held during this step. If the feet change position, they should be allowed to remain in that attitude for the moment.

Carefully return the back pan to the seat-back and check the two spirit levels for zero position. If any movement of the feet has occurred during the rocking operation of the 3-D H machine, they must be repositioned as follows:

Alternately, lift each foot off the floor the minimum necessary amount until no additional foot movement is obtained. During this lifting, the feet are to be free to rotate; and no forward or lateral loads are to be applied. When each foot is placed back in the down position, the heel is to be in contact with the structure designed for this.

Check the lateral spirit level for zero position; if necessary, apply a lateral load to the top of the back pan sufficient to level the 3-D H machine's seat pan on the seat.

- 4.13. Holding the T-bar to prevent the 3-D H machine from sliding forward on the seat cushion, proceed as follows:
 - (a) return the back pan to the seat-back;
 - (b) alternately apply and release a horizontal rearward load, not to exceed 25 N, to the back angle bar at a height approximately at the centre of the torso weights until the hip angle quadrant indicates that a stable position has been reached after load release. Care shall be exercised to ensure that no exterior downward or lateral loads are applied to the 3-D H machine. If another level adjustment of the 3-D H machine is necessary, rotate the back pan forward, re-level, and repeat the procedure from paragraph 4.12.
- 4.14. Take all measurements:
 - 4.14.1. The co-ordinates of the "H" point are measured with respect to the three-dimensional reference system.
 - 4.14.2. The actual torso angle is read at the back angle quadrant of the 3-D H machine with the probe in its fully rearward position.
- 4.15. If a re-run of the installation of the 3-D H machine is desired, the seat assembly should remain unloaded for a minimum period of 30 min prior to the re-run. The 3-D H machine should not be left loaded on the seat assembly longer than the time required to perform the test.
- 4.16. If the seats in the same row can be regarded as similar (bench seat, identical seats, etc.) only one "H" point and one "actual torso angle" shall be determined for each row of seats, the 3-D H machine described in Appendix 1 to this annex being seated in a place regarded as representative for the row. This place shall be:
 - 4.16.1. in the case of the front row, the driver's seat;
 - 4.16.2. in the case of the rear row or rows, an outer seat.

Annex 6 - Appendix 1

DESCRIPTION OF THE THREE-DIMENSIONAL "H" POINT MACHINE 1/
(3-D H machine)

1. Back and seat pans

The back and seat pans are constructed of reinforced plastic and metal; they simulate the human torso and thigh and are mechanically hinged at the "H" point. A quadrant is fastened to the probe hinged at the "H" point to measure the actual torso angle. An adjustable thigh bar, attached to the seat pan, establishes the thigh centreline and serves as a baseline for the hip angle quadrant.

2. Body and leg elements

Lower leg segments are connected to the seat pan assembly at the T-bar joining the knees, which is a lateral extension of the adjustable thigh bar. Quadrants are incorporated in the lower leg segments to measure knee angles. Shoe and foot assemblies are calibrated to measure the foot angle. Two spirit levels orient the device in space. Body element weights are placed at the corresponding centres of gravity to provide seat penetration equivalent to a 76 kg male. All joints of the 3-D H machine should be checked for free movement without encountering noticeable friction.

1/ For details of the construction of the 3-D H machine refer to Society of Automobile Engineers (SAE), 400 Commonwealth Drive, Warrendale, Pennsylvania 15096, United States of America. The machine corresponds to that described in ISO Standard 6549-1980.

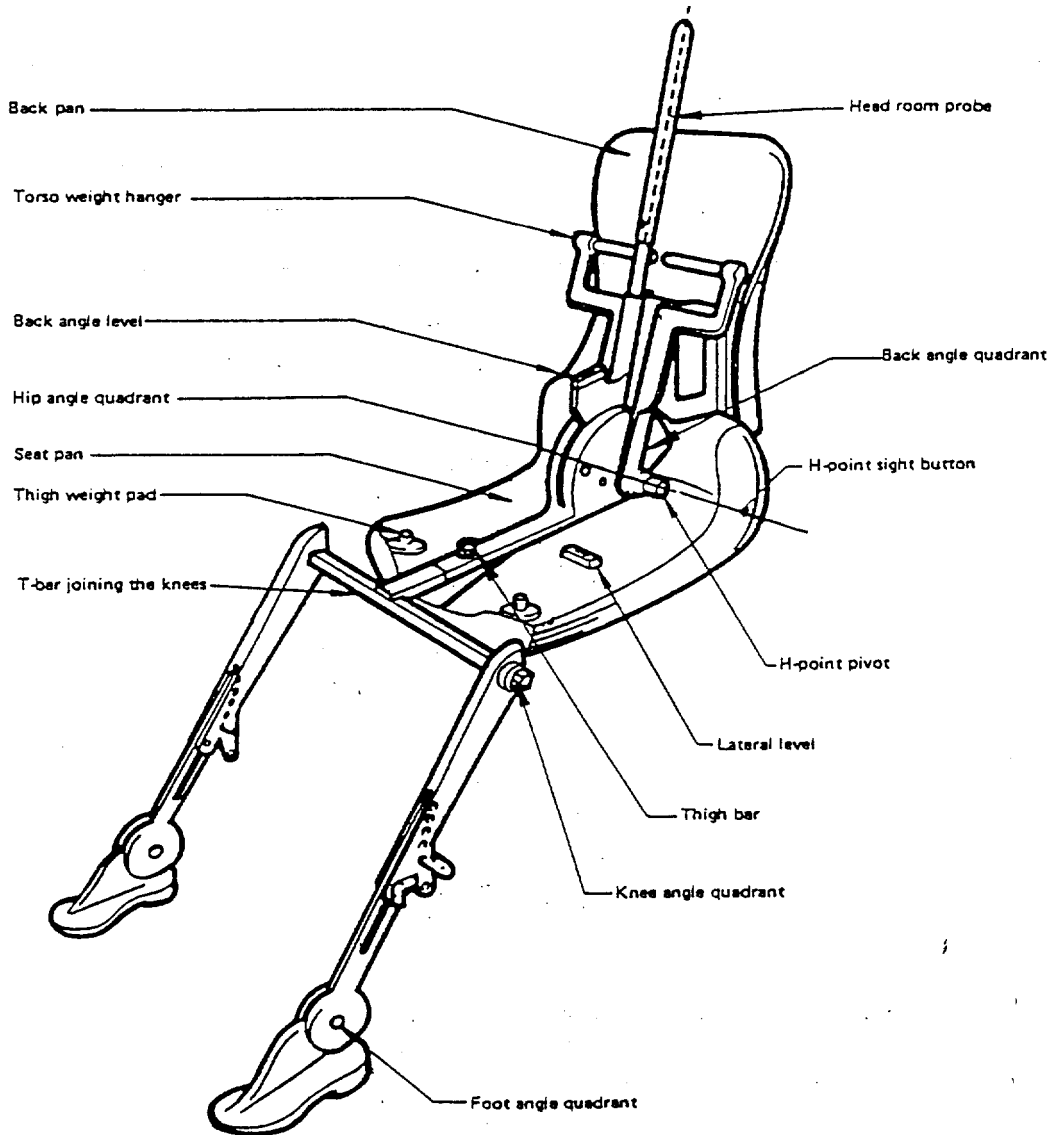

Figure 1 - 3-D H machine elements designation

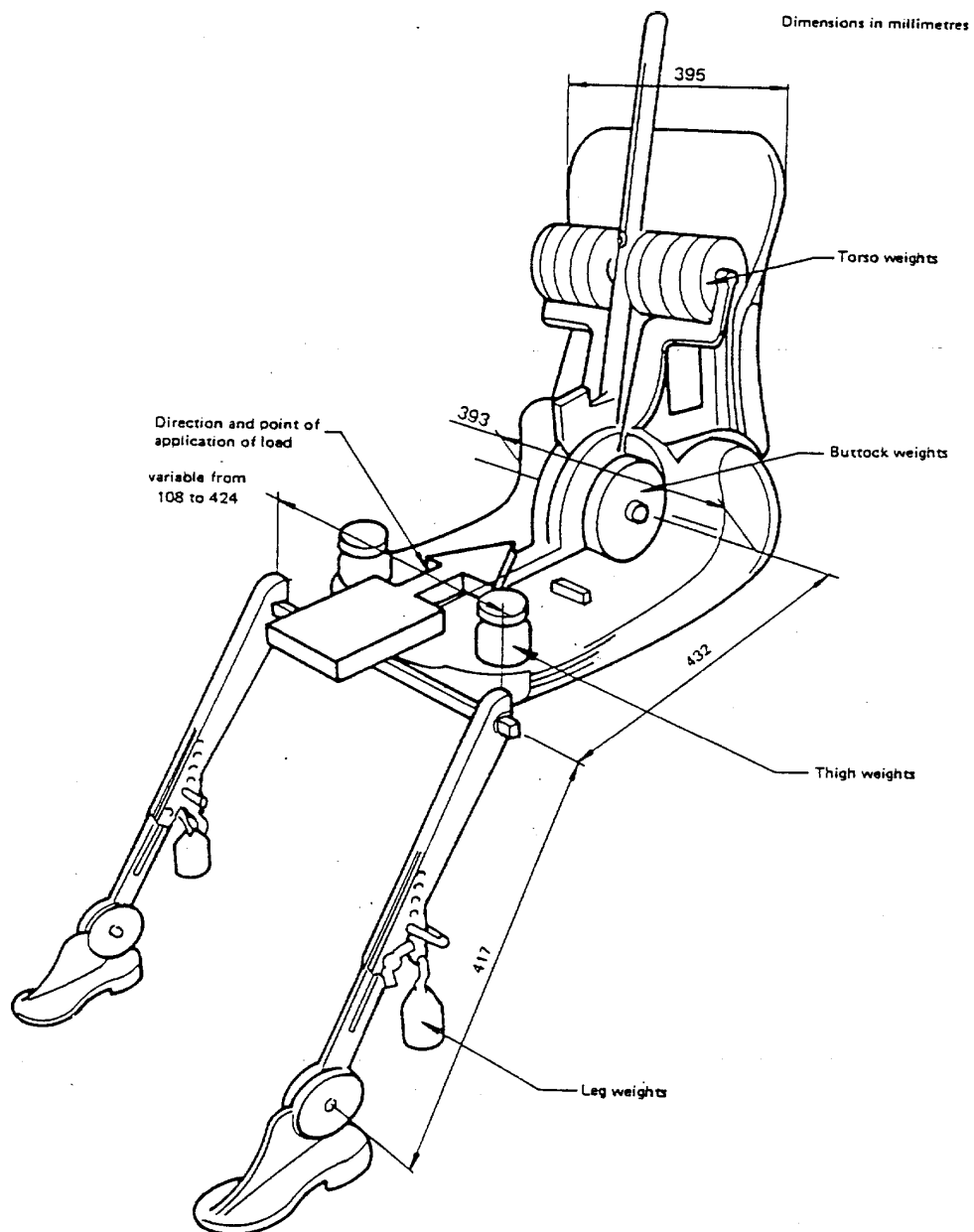

Figure 2 - Dimensions of the 3-D H machine elements and load distribution

Annex 6 - Appendix 2

THREE-DIMENSIONAL REFERENCE SYSTEM

1. The three-dimensional reference system is defined by three orthogonal planes established by the vehicle manufacturer (see figure). 1/
2. The vehicle measuring attitude is established by positioning the vehicle on the supporting surface such that the co-ordinates of the fiducial marks correspond to the values indicated by the manufacturer.
3. The co-ordinates of the "R" point and the "H" point are established in relation to the fiducial marks defined by the vehicle manufacturer.

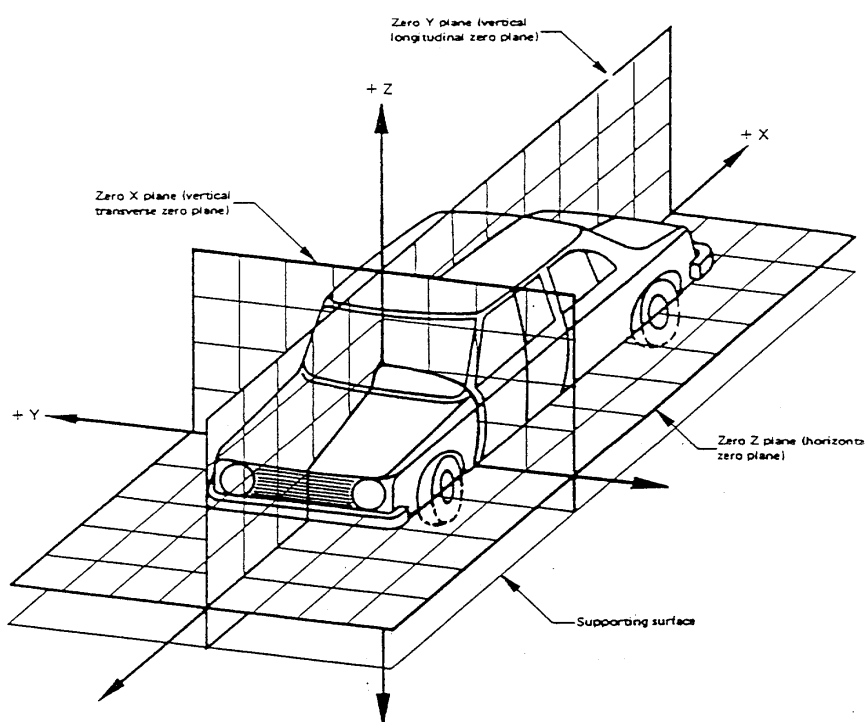

Figure - Three-dimensional reference system

1/ The reference system corresponds to ISO Standard 4130, 1978

Annex 7

REFERENCE DATA CONCERNING SEATING POSITIONS

1. Coding of reference data

Reference data are listed consecutively for each seating position. Seating positions are identified by a two-digit code. The first digit is an Arabic numeral and designates the row of seats, counting from the front to the rear of the vehicle. The second digit is a capital letter which designates the location of the seating position in a row, as viewed in the direction of forward motion of the vehicle; the following letters shall be used:

L = left
C = centre
R = right

2. Description of vehicle measuring attitude

2.1. Co-ordinates of fiducial marks.

X
Y
Z

3. List of reference data:

3.1. Seating position:

3.1.1. Co-ordinates of "R" point:

X
Y
Z

3.1.2. Design torso angle:

3.1.3. Specifications for seat adjustment 1/

horizontal:
vertical:
angular:
torso angle:

Note: List reference data for further seating positions under items 3.2., 3.3., etc.

1/ Strike out what does not apply

B. JUSTIFICATION

I. Introduction

As a follow-up to the papers submitted to the 15 May 2006 meeting of the GRSP Informal Group, OICA has prepared a first draft of a detailed proposal to amend Regulation No 29.

As already indicated in previous GRSP sessions, OICA is actively involved in the commercial vehicle cab strength issue. An expert group comprising experts from all over the world has studied in detail all available accident data (United States of America: FARS, NTSB / Europe: Volvo, CEESAR / Japan: JASIC) and has elaborated a technical proposal aimed at further improving truck cab safety.

While OICA would fully support the development of a global technical regulation under the framework of the 1998 Agreement, OICA fully recognizes the validity of the decision reached by WP.29 at its one-hundred-and-fortieth session in 2006 to concentrate, for the near future, on the further development of Regulation No. 29 under the 1958 Agreement.

OICA has consequently translated the results of its past work into a proposal to amend Regulation No 29, with the understanding that such work could hopefully be used as a basis to develop a global technical regulation in the future.

This proposal takes into account the legal structure of a Regulation under the 1958 Agreement; it should however be stressed that some of the OICA proposals may not be appropriate for all Contracting Parties to the 1958 Agreement, because the local situation does not necessarily justify a mandatory application of all the proposed tests. OICA believes that action under the 1998 Agreement could have provided a high level of global harmonisation without imposing mandatory requirements in countries where local conditions do not justify them. Further explanations can be found below.

II. Most relevant accident scenarios

As already indicated in the May 2006 meeting of the GRSP informal Group, a detailed analysis of heavy truck accident data all over the world identifies three critical impact scenarios:

1. Front to rear impact:

In this case, a truck impacts the rear of the preceding vehicle. In a very large majority of cases, the overlap is high, with typical figures ranging from 70 to 100 per cent.

Based on available data and on various tests and simulations, OICA considers that the current frontal impact test procedure of Regulation No. 29 is adequate and should be retained, without drastic changes, except for the energy level, which for heavy trucks could be increased to 50 kJ, representing an increase of 13 per cent compared to the current situation.

2. 90° rollover, followed by subsequent impact:

Accident statistics indicate that this accident scenario is quite frequent and represents a large proportion of accidents which cause injuries and fatalities. In this scenario, the truck rolls over through 90° and continues to move forward on its side, until it impacts a fixed obstacle (e.g. a pillar, a tree, a guard rail, etc.) at the level of the A-pillar/front corner of the cab. Such an impact results in a longitudinal load on the cab structure and Sweden already has a national requirement for an A-pillar test to simulate this.

A detailed analysis of 455 truck accidents with driver injury shows the following:

54 per cent of the accidents are single vehicle accidents. There is a rollover in 68 per cent of these single vehicle accidents.

Due to a subsequent impact following the rollover, the upper A-pillar is deformed in 39 per cent of the single vehicle accidents, i.e. 21 per cent of all accidents in the sample.

OICA has consequently developed a test procedure representing this accident configuration, thereby ensuring that the observed deformations are representative of the real world and taking into account the need for good repeatability and practicability of the test.

3. 180° rollover:

The typical scenario in this case would be that the truck first rolls over at 90°, causing a lateral/transversal loading of the cab, followed by the complete 180° rollover and consequently a vertical load on the roof.

On this basis, OICA proposes to improve the current roof load test of Regulation No 29, by laterally and dynamically loading the truck cab, before applying the vertical quasi-static load. This test configuration is largely based on the existing standard SAE J 2422, commonly used by United States truck manufacturers.

However, it needs to be recognised that available accident data are not 100 per cent coherent with regard to the 180° rollover accident. At least in some regions, this accident does not appear to be fully relevant, but OICA has sufficient data to establish that this type of accident, though not necessarily very frequent, is assumed to be responsible for a significant number of injuries and fatalities at least in Europe and North America. Based on the legal

framework of the 1958 Agreement and on the fact that the roof load is already part of the mandatory requirements in Regulation No. 29, OICA proposes to retain this test configuration, with, however, the understanding that such mandatory test may not be fully justified in some regions.

III. Rear wall test

Available statistics show that injuries and fatalities caused by a shift of the load towards the cab are very rare, representing less than 2 per cent of the total.

OICA consequently considers that this accident type should not be considered in the future evolution of the cab strength requirements for heavy trucks and should be deleted, in order to be replaced by the far more important test representing a 90° rollover with subsequent impact.

IV. Vehicle categories addressed by the OICA studies

While OICA understands that all commercial vehicle categories need to be addressed one way or another, it is important to take into account the various design and construction types.

The OICA proposals to amend Regulation No. 29 are based on accident data, tests and calculations related to heavy trucks, with a GVM above 7.5t.

For lighter trucks (N₁ and N₂ below 7.5t GVM), OICA has no data justifying amendments to the current requirements of Regulation No. 29 and recommends that the existing requirements of the 02 series of amendments should remain applicable to these vehicle categories.

On this basis, OICA has prepared the following proposal to amend Regulation No. 29, simply referring, for light trucks below 7.5t GVM, to the existing requirements of the 02 series of amendments. The proposed new tests and requirements of the 03 series of amendments would specifically address heavy trucks only.

The proposal which follows therefore only describes the proposed changes to the test procedures and requirements for heavy trucks. For the lighter trucks, a simple statement is proposed, referring to the existing requirements of the 02 series of amendments which remain applicable.

However, if GRSP decides that, from an administrative point of view, it is appropriate to use another approach, OICA is willing to draft a new proposal, detailing the requirements and test procedures for each of the vehicle categories.
