



**Economic and Social  
Council**

Distr.  
GENERAL

ECE/TRANS/WP.29/GRSG/2006/34/Rev.1  
8 August 2007

Original: ENGLISH

---

**ECONOMIC COMMISSION FOR EUROPE**

**INLAND TRANSPORT COMMITTEE**

World Forum for Harmonization of Vehicle Regulations

Working Party on General Safety Provisions

Ninety-third session

Geneva, 23-26 October 2007

Item 12. of the provisional agenda

Draft horizontal Regulation on country codes, vehicle categories and definitions

Proposal for a new draft horizontal regulation

Submitted by the expert from the European Commission (EC)

Note: The text reproduced below was prepared by the expert from the European Commission (EC) in order to improve the management of the Regulations annexed to the 1958 Agreement. The proposal consolidates and supersedes document ECE/TRANS/WP.29/GRSG/2006/34. The texts marked in **bold** characters complete and modify the proposals reproduced in that document.

A. PROPOSAL

HORIZONTAL REGULATION ON COUNTRY CODES, VEHICLE CATEGORIES AND DEFINITIONS

1. Scope

This Regulation covers country codes, vehicle categories and definitions under the revised 1958 Agreement 1/.

2. Country codes

See Annex 1.

3. Rules with regard to vehicle definitions and masses

3.1. Vehicle definitions

3.1.1. "Vehicle" or "Road vehicle" means any wheeled structure with a maximum design speed of more than 6 km/h intended for circulation on the road that is either self-propelled or towed by a self-propelled structure.

3.1.2. "Power-driven vehicle" means any self-propelled vehicle.

3.1.3. "Motor vehicle" means a power-driven vehicle, other than agricultural and forestry tractors (see para. 4.6.) and mobile machinery (see para. 5.1.).

3.1.4. "Trailer" means any non-self propelled vehicle, which is designed and constructed to be towed by a power-driven vehicle.

3.1.5. "Towing vehicle" 2/ means any self-propelled vehicle the principle purpose of which is to tow a trailer.

3.1.6. "Vehicle combination" means any ensemble constituted by a power-driven vehicle coupled to one or more trailer(s).

---

1/ Agreement concerning the Adoption of Uniform Technical Prescriptions for Wheeled Vehicles, Equipment and Parts which can be Fitted and/or be Used on Wheeled Vehicles and the Conditions for Reciprocal Recognition of Approvals Granted on the Basis of these Prescriptions, done at Geneva on 20 March 1958 (including the amendments which entered into force on 16 October 1995) (document E/ECE/324-E/ECE/TRANS/505/Rev.2).

2/ Towing vehicles may be called "tractors", "truck tractors", "tractors for semi-trailers", "tractor units" or "tractive units" in some of the Regulations.

- 3.1.7. "Incomplete vehicle" means any vehicle, which requires completion of at least one further stage of construction before being ready for the purpose for which it has been designed and constructed.
- 3.1.8. "Complete vehicle" means any vehicle which does not require further construction stages in order to be fit for the purpose for which it has been designed and constructed.
- 3.1.9. "Seating position" means any individual seat or any part of a bench seat intended to seat one person. If there is a seat anchorage point available for a removable seat, it shall be counted in the determination of the number of seating positions and of the mass.
- 3.1.10. **In cases where it is not immediately apparent whether a motor vehicle is a category M or N vehicle, a motor vehicle is deemed to be in the N category if it meets all the following conditions:**

$$X > S \times 68$$

$$X > 150 \text{ kg}$$

$$S \leq 6 \text{ for vehicles with a maximum mass not exceeding 3,5 tonnes}$$

$$S \leq 8 \text{ for all other vehicles}$$

where:

P = gross vehicle mass in kg

R = mass in running order in kg

S = number of **adult seating and standing positions**

$$X = \text{paymass} = P - (R + S \times 68)$$

- 3.1.11. If a motor vehicle does not qualify as a vehicle used for the carriage of goods (see para. 3.1.10.), it is deemed to be designed and constructed for the carriage of passengers.

## 3.2. Definitions used for vehicle masses

- 3.2.1. "Unladen vehicle mass" means the nominal mass of the vehicle as indicated by the manufacturer(s) including all factory fitted standard equipment for the normal operation of that vehicle (e.g. fire extinguisher, tools, spare wheel), plus coolant, oils, 90 per cent of fuel and 100 per cent of other gas or liquids, as specified by the manufacturer, with the exception of used water. In the case of mobile machinery, the machinery shall be considered as ready for operation. **In the case of alternative fuels, e.g. LPG, the tank shall be filled to its legal maximum.**
- 3.2.2. "Mass of a vehicle in running order" means the unladen vehicle mass with the addition of a driver (75 kg) and, for vehicles designed and constructed for the carriage of more than 8 persons (in addition to the driver), the mass of a crew member (75 kg), if there is a crew seat amongst the 9 or more seats. In the case of mobile machinery, the special tools, appliances, working materials, etc., if any, shall be included as well as the mass of the crew members (each 75 kg).

3.2.3. "Gross vehicle mass" or "maximum mass" means the technically permissible maximum laden mass as declared by the manufacturer. In the case of a towing vehicle designed to be coupled to a semitrailer (tractor for semitrailer) or centre axle-trailer, the mass to be considered for classifying the vehicle is the mass of the tractor vehicle in running order, increased by the mass corresponding to the maximum static vertical load transferred to the tractor vehicle by the semitrailer or centre-axle trailer and, where applicable, by the maximum mass of the tractor vehicle's own load.

3.2.4. "Maximum mass of trailers" means the static vertical load transmitted to the ground by the axle or axles of the trailer, **increased by the static vertical load, if any, transferred from the trailer to the towing vehicle at the coupling point when the trailer is carrying its maximum load. The mass to be considered for classifying the trailer is the static vertical load transmitted to the ground by the axle or axles of the trailer when carrying its maximum load as declared by the manufacturer.**

3.2.5. "Maximum mass of a combination of vehicles" means the total mass of a combination of motor vehicle and trailer(s) as stated by the motor vehicle manufacturer. The maximum mass of the combination is the sum of the gross vehicle mass of the towing vehicle and of the maximum mass of the trailer minus the mass transferred from the trailer to the towing vehicle.

### 3.3. Rules relating to equipment and multistage construction

3.3.1. Equipment not counted under paragraph 3.2.1. or 3.2.2 is deemed to be load.

3.3.2. The equipment and installations carried on a vehicle (of crane vehicles, workshop vehicles, publicity vehicles, etc.) are regarded as being equivalent to goods. A vehicle that has received an approval as an N category vehicle shall not be reclassified as mobile machinery in the process of multi-stage construction.

3.3.3. **In case of multi-stage construction, all masses and approvals shall be verified at each stage of completion.**

## 4. CLASSIFICATION OF POWER-DRIVEN VEHICLES AND TRAILERS

### 4.1. Category L – light motor vehicles

"Category L vehicle" means a motor vehicle with two, three or four wheels and, in the case of the four-wheeled vehicles, with limited performance and mass (see paras 4.1.6. and 4.1.7.).

4.1.1. Category L<sub>1</sub>

A two-wheeled vehicle, whose maximum design speed is not more than **[45]** km/h, and whose engine cylinder capacity does not exceed 50 cm<sup>3</sup> **for internal combustion engines[, or whose maximum continuous rated power does not exceed 4 kW in the case of electric engines].**

4.1.2. Category L<sub>2</sub>

A three-wheeled vehicle of any wheel arrangement, whose maximum design speed is not more than **[45]** km/h, and whose engine cylinder capacity does not exceed 50 cm<sup>3</sup> **[for spark (positive) ignition engines, or whose maximum net power output does not exceed 4 kW in the case of other internal combustion engines, or whose maximum continuous rated power does not exceed 4 kW in the case of electric engines].**

4.1.3. Category L<sub>3</sub>

A two-wheeled vehicle having an engine cylinder capacity, in the case of an internal combustion engine, exceeding 50 cm<sup>3</sup> or, whatever the means of propulsion, a maximum design speed exceeding **[45]** km/h.

4.1.4. Category L<sub>4</sub>

A vehicle with **three** wheels asymmetrically arranged in relation to the longitudinal median plane with an engine cylinder capacity, in the case of an internal combustion engine, exceeding 50 cm<sup>3</sup> or, whatever the means of propulsion, a maximum design speed exceeding **[45]** km/h (motorcycles with sidecars).

4.1.5. Category L<sub>5</sub>

A vehicle with three wheels symmetrically arranged in relation to the longitudinal median plane with an engine cylinder capacity in the case of an internal combustion engine exceeding 50 cm<sup>3</sup> or, whatever the means of propulsion, a maximum design speed exceeding **[45]** km/h.

4.1.6. Category L<sub>6</sub>

A vehicle with four wheels whose unladen mass is not more than 350 kg, not including the mass of the batteries in case of electric vehicles, whose maximum design speed is not more than **45** km/h, and whose engine cylinder capacity does not exceed 50 cm<sup>3</sup> **for spark (positive) ignition engines, or whose maximum net power output does not exceed 4 kW in the case of other** internal combustion engines, or whose **maximum** continuous rated power does not exceed 4 kW in the case of electric engines.

**[Vehicles of categories L6 belong to Class I if they**

- **have seats**
- **are horizontally confined by a body,**
- **have a roof or other rollover protection,**
- **are steered by a steering wheel and**
- **have foot-throttle control**

**Vehicles of categories L6 belong to Class II if they**

- **have saddles, but no seats,**
- **have no body,**
- **have no roof or other rollover protection,**
- **are steered by a handlebar and**
- **have a hand-throttle control]**

4.1.7. Category L<sub>7</sub>

A vehicle with four wheels, other than that classified for the category L6, whose unladen mass is not more than 400 kg (550 kg for vehicles intended for carrying goods), not including the mass of the batteries in the case of electric vehicles, and whose maximum continuous rated power does not exceed 15 kW **in the case of electric engines, or whose maximum net power output does not exceed 15 kW in the case of internal combustion engines.**

**[Vehicles of categories L7 belong to Class I if they**

- **have seats**
- **are horizontally confined by a body,**
- **have a roof or other rollover protection,**
- **are steered by a steering wheel and**
- **have foot-throttle control**

**Vehicles of categories L7 belong to Class II if they**

- **have saddles, but no seats,**
- **have no body,**
- **have no roof or other rollover protection,**
- **are steered by a handlebar and**
- **have a hand-throttle control]**

4.2. Category M - motor vehicles for the carriage of passengers, **having at least four wheels**

"Category M vehicle" means a motor vehicle with four or more wheels designed and constructed for the carriage of passengers.

4.2.1. Category M<sub>1</sub>

Vehicles comprising not more than eight **seating positions** in addition to the driver's seat and without space for standing passengers.

4.2.2. Category M<sub>2</sub>

Vehicles comprising more than eight **seating [or standing] positions**, in addition to the driver's seat, and having a gross vehicle mass not exceeding 5 tonnes.

4.2.3. Category M<sub>3</sub>

Vehicles comprising more than eight **seating [or standing] positions**, in addition to the driver's seat, and having a gross vehicle mass exceeding 5 tonnes.

4.2.4. **Sub-classes of vehicles in category M2 and M3**

4.2.4.1 **Vehicles having a capacity exceeding 22 passengers in addition to the driver**

4.2.4.1.1. Class I

Vehicles designed and constructed with areas for standing passengers, to allow frequent passenger movement.

4.2.4.1.2. Class II

Vehicles designed and constructed principally for the carriage of seated passengers, and designed and constructed to allow the carriage of standing passengers in the gangway and/or in an area which does not exceed the space provided for two double seats.

4.2.4.1.3. Class III

Vehicles designed and constructed exclusively for the carriage of seated passengers.

4.2.4.1.4 Vehicles belonging to more than one class

These vehicles shall be approved to each class to which they correspond.

4.2.4.2 **Vehicles having a capacity not exceeding 22 passengers in addition to the driver**

4.2.4.2.1 Class A

Vehicles designed and constructed to carry seated and standing passengers.

4.2.4.2.2 Class B

Vehicles designed and constructed exclusively for the carriage of seated passengers.

**4.3. Category N - power-driven vehicles designed and constructed for the carriage of goods, having at least four wheels.**

**This category shall also include:**

**- tractive units**

**- chassis designed specifically to be equipped with special equipment.**

4.3.1. Category N<sub>1</sub>

Vehicles having a gross vehicle mass not exceeding 3.5 tonnes.

4.3.2. Category N<sub>2</sub>

Vehicles having a gross vehicle mass exceeding 3.5 tonnes but not exceeding 12 tonnes.

4.3.3. Category N<sub>3</sub>

Vehicles having a gross vehicle mass exceeding 12 tonnes.

**4.4. Category O - trailers -vehicles designed to be towed by a power-driven vehicle**

4.4.1. Category O<sub>1</sub>

Trailers with a **maximum mass** not exceeding 0.75 tonnes.

4.4.2. Category O<sub>2</sub>

Trailers with a **maximum mass** exceeding 0.75 tonnes, but not exceeding 3.5 tonnes.

4.4.3. Category O<sub>3</sub>

Trailers with a **maximum mass** exceeding 3.5 tonnes, but not exceeding 10 tonnes.

4.4.4. Category O<sub>4</sub>

Trailers with a **maximum mass** exceeding 10 tonnes.

4.4.5. Furthermore, trailers are of one of the three following types:



4.4.5.1. "Semi-trailer"

A trailer, in which the axle(s) is (are) positioned behind the centre of gravity of the vehicle (when uniformly loaded), and which is equipped with a connecting device permitting horizontal and vertical forces to be transmitted to the towing vehicle. One or more of the axles may be driven by the towing vehicle.

4.4.5.2. "Full trailer"

A trailer having at least two axles, and equipped with a towing device which can move vertically (in relation to the trailer) and controls the direction of the front axle(s), but which transmits no significant static load to the towing vehicle. One or more of the axles may be driven by the towing vehicle.

4.4.5.3. "Centre-axle trailer"

A trailer, equipped with a towing device which cannot move vertically (in relation to the trailer) and in which the axle(s) is (are) positioned close to the centre of gravity of the vehicle (when uniformly loaded) such that only a small static vertical load, not exceeding 10 per cent of that corresponding to the gross vehicle mass of the trailer or a load of 1,000 daN (whichever is the lesser) is transmitted to the towing vehicle. One or more of the axles may be driven by the towing vehicle.

4.5. Special purpose vehicle

"Special purpose vehicles" belong either to category L, M, N or O for conveying passengers or goods and have to fulfil the requirements of these categories wherever appropriate. A vehicle qualifies as special purpose vehicle if it fulfils an additional function for which special body arrangements and/or equipment are necessary. **The following list is exclusive.**

4.5.1. Motor caravan (SA)

M category vehicle with accommodation space which contains at least the following rigidly fixed equipment:

- (a) seats and a (possibly removable) table;
- (b) sleeping accommodation which may be converted from the seats;
- (c) cooking facilities, and
- (d) storage facilities

4.5.2. Armoured vehicle (SB)

Vehicle with anti-bullet armour plating.

4.5.3. Ambulance (SC)

Vehicle of category M for the transport of sick or injured people and having special equipment for such purpose.

4.5.4. Hearse (SD)

Vehicle of category M for the transport of deceased people and having special equipment for such purpose.

**4.5.5. Wheel-chair accessible vehicle (SE)**

**Vehicle of category M1 constructed or converted specifically so that it accommodates one or more person(s) seated in their wheel-chair(s) when travelling on the road.**

**4.5.6. Police motorcycles (SF)**

**Vehicles of categories L1 and L3, adapted for use by the police.**

4.6. Category T - agricultural and forestry tractors

"Agricultural and forestry tractor" means a power-driven vehicle, either wheeled or track-laying, which has at least two-axles, whose function depends essentially on its tractive power, and which is specially designed and constructed to pull, push, carry or actuate certain implements, machines or trailers intended for use in agriculture or forestry. Such a tractor may be designed, constructed or adapted to carry a load and attendants.

4.7. Category G - off-road vehicles

"Off-road vehicle" Vehicle that belongs either to category M or to category N and has to fulfil the requirements of these categories unless it is otherwise stated in a specific Regulation. A vehicle qualifies as an off-road vehicle if it fulfils the following requirements relevant to the respective category:

4.7.1. Vehicles in category N<sub>1</sub> with a gross vehicle mass not exceeding 2 tonnes and all vehicles in category M<sub>1</sub> are considered to be off-road vehicles if they:

4.7.1.1. have at least one front axle and at least one rear axle designed and constructed to be driven simultaneously, including where the drive to one axle can be disengaged;

4.7.1.2. have at least one differential locking mechanism or at least one mechanism having a similar effect; and

4.7.1.3. can climb a 30 per cent gradient calculated for a solo vehicle.

- 4.7.1.4 in addition, satisfy a least five of the following six requirements:
- (a) the approach angle must be at least 25°;
  - (b) the departure angle must be at least 20°;
  - (c) the ramp angle must be at least 20°;
  - (d) the ground clearance under the front axle must be at least 180 mm;
  - (e) the ground clearance under the rear axle must be at least 180 mm;
  - (f) the ground clearance between the axles must be at least 200 mm.
- 4.7.2. Vehicles in category N<sub>1</sub> with a gross vehicle mass exceeding 2 tonnes or in category N<sub>2</sub>, M<sub>2</sub> or M<sub>3</sub> with a gross vehicle mass not exceeding 12 tonnes are considered to be off-road vehicles either if all their wheels are designed and constructed to be driven simultaneously, including vehicles where the drive to one axle can be disengaged, or if the following three requirements are satisfied:
- (a) at least one front axle and at least one rear axle are designed and constructed to be driven simultaneously, including vehicles where the drive to one axle can be disengaged;
  - (b) there is at least one differential locking mechanism or at least one mechanism having a similar effect;
  - (c) they can climb a 25 per cent gradient calculated for a solo vehicle.
- 4.7.3. Vehicles in category M<sub>3</sub> with a gross vehicle mass exceeding 12 tonnes or in category N<sub>3</sub> are considered to be off-road either if the wheels are designed and constructed to be driven simultaneously, including vehicles where the drive to one axle can be disengaged, or if the following requirements are satisfied:
- (a) at least half the wheels are driven;
  - (b) there is at least one differential locking mechanism or at least one mechanism having a similar effect;
  - (c) they can climb a 25 per cent gradient calculated for a solo vehicle;
  - (d) at least four of the following six requirements are satisfied:
    - (i) the approach angle must be at least 25°;
    - (ii) the departure angle must be at least 25°;
    - (iii) the ramp angle must be at least 25°;
    - (iv) the ground clearance under the front axle must be at least 250 mm;
    - (v) the ground clearance between the axles must be at least 300 mm;
    - (vi) the ground clearance under the rear axle must be at least 250 mm.
- 4.7.4. Load and checking conditions
- 4.7.4.1. Vehicles in category N<sub>1</sub> with a gross vehicle mass not exceeding two tonnes and vehicles in category M<sub>1</sub> must be in running order.
- 4.7.4.2. Motor vehicles other than those referred to in paragraph 4.7.2.1. must be loaded to the technically permissible gross vehicle mass stated by the manufacturer.
- 4.7.4.3. The ability to climb the required gradients (25 per cent and 30 per cent) is verified by simple calculation. In exceptional cases, however, the Technical Services may ask for a vehicle of the type concerned to be submitted to it for an actual test.

4.7.4.4. When measuring **approach** and **departure** angles and ramp angles, no account is taken of underrun protective devices.

4.7.5. Definitions and sketches of front and rear incidence angles, ramp angle and ground clearance.

4.7.5.1. "Approach angle" - see ISO 612:1978, term No. 6.10.

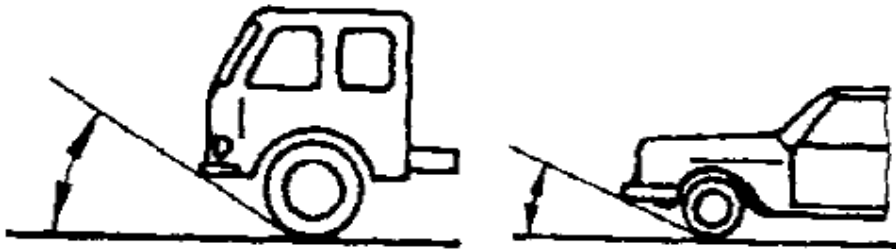

4.7.5.2. "Departure angle" - see ISO 612:1978, term No. 6.11.

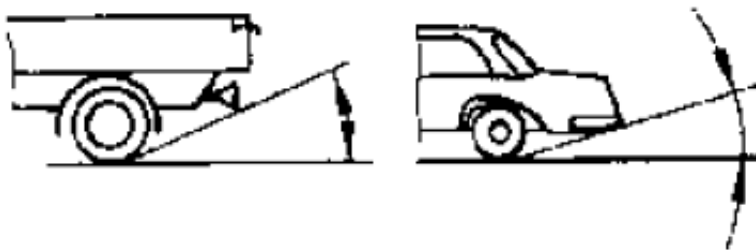

4.7.5.3. "Ramp angle" - see ISO 612:1978, term No. 6.9.

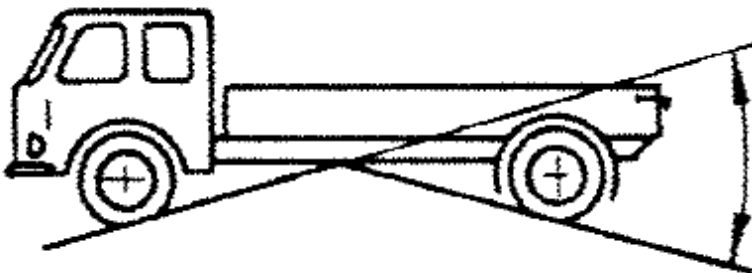

4.7.5.4. "Ground clearance between the axles" means the shortest distance between the ground plane and the lowest fixed point of the vehicle.

Multi-axle bogies are considered to be a single axle.

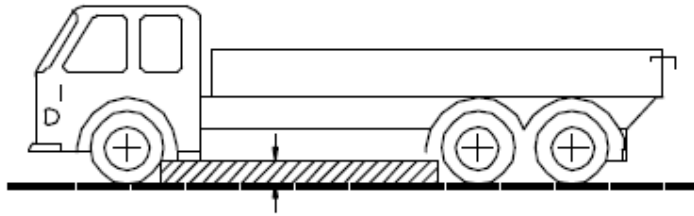

- 4.7.5.5. "Ground clearance beneath one axle" means the distance beneath the highest point of the arc of a circle passing through the centre of the tyre footprint of the wheels on one axle (the inner wheels in the case of twin tyres) and touching the lowest fixed point of the vehicle between the wheels. No rigid part of the vehicle may project into the shaded area of the diagram. Where appropriate, the ground clearance of several axles is indicated in accordance with their arrangement, for example 280/250/250.

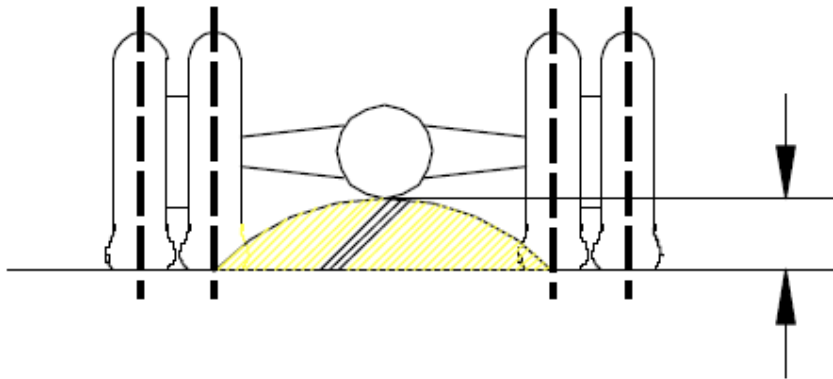

- 4.7.6. Combined designation.

Symbols M and N may be combined with symbol G. For example, a vehicle of category  $N_1$  which is suited for off-road use may be designated as  $N_1G$ .

## 5. OTHER DEFINITIONS

- 5.1. "Mobile machinery" means a vehicle which is specifically designed and constructed to perform work and which, because of its construction characteristics, is not suitable for transporting goods or carrying passengers other than any operators/crew. **Vehicles in categories L, M, N, O and T** equipped with machinery shall not be considered as mobile machinery, unless so requested by the manufacturer.

## 6. RULES OF APPLICATION

### 6.1. References to R.E.3 1/ and to this Regulation

- 6.1.1. All explicit references to vehicle **classification** in any version of R.E.3, Annex 7 adopted earlier than this Regulation remain valid. Contracting Parties shall make sure that their Technical Services use the version of R.E.3 that was applicable when the Regulation or its amendment was adopted.
- 6.1.2. If a Regulation or an amendment to it has been adopted earlier than this Regulation and mentions a certain vehicle category, this shall be regarded as a reference to the version of R.E.3, Annex 7 applicable when the Regulation or its amendment was adopted, unless otherwise specified.
- 6.1.3. Any Regulation or amendment referring to this Regulation refers to the latest version unless otherwise specified. If the reference is made to the Horizontal Regulation applicable at a certain date, Contracting Parties shall make sure that their Technical Services use that version.
- 6.1.4. Future Regulations, and amendments modifying the scope of any Regulation, shall only refer to vehicle categories specified in this Regulation or R.E.3, Annex 7. However, individual Regulations may include **sub-classifications** for technical specifications.
- 6.1.5. Contracting Parties may continue to apply their national or regional definitions in their domestic legislation.**

Annex 1

COUNTRY CODES FOR TYPE APPROVALS, MARKS AND COMMUNICATION FORMS

E 1 Germany	E 26 Slovenia
E 2 France	E 27 Slovakia
E 3 Italy	E 28 Belarus
E 4 Netherlands	E 29 Estonia
E 5 Sweden	E 31 Bosnia and Herzegovina
E 6 Belgium	E 32 Latvia
E 7 Hungary	E 34 Bulgaria
E 8 Czech Republic	E 36 Lithuania
E 9 Spain	E 37 Turkey
E 10 Serbia	E 39 Azerbaijan
E 11 United Kingdom	E 40 Former Yugoslav Republic of Macedonia
E 12 Austria	E 42 European Community */
E 13 Luxembourg	E 43 Japan
E 14 Switzerland	E 45 Australia
E 16 Norway	E 46 Ukraine
E 17 Finland	E 47 South Africa
E 18 Denmark	E 48 New Zealand
E 19 Romania	E 49 Cyprus
E 20 Poland	E 50 Malta
E 21 Portugal	E 51 Republic of Korea
E 22 Russian Federation	E 52 Malaysia
E 23 Greece	E 53 Thailand
E 24 Ireland	<b>E 56 Montenegro</b>
E 25 Croatia	

B. JUSTIFICATION

The text down to § 4.2.1.2 was agreed by GRSG, with the exception of certain detailed issues. These issues have been discussed by the drafting group on the Horizontal Regulation during the meeting of 24-25 January 2007 and the meeting of 16 April 2007. Amendments to Document ECE/TRANS/WP.29/GRSG/2006/34 are shown in **bold type**. The remaining open issues are shown in red and square brackets.

This Horizontal Regulation aims at improving the management of legislation within the framework of the 1958 Agreement. It allows a more systematic shift from one set of vehicle categories to another. In addition, backlogs regarding the updating of Country Codes for each Regulation can be avoided. Finally, a Horizontal Regulation will, in the medium term, permit harmonized and centralized definitions to be used in many regulations. In the future, it might be used for other purposes as well.

How is a new vehicle category, e.g. L<sub>6</sub> and L<sub>7</sub>, put into the 1958 Agreement system today? Firstly, it is introduced into the non-binding resolution R.E.3, Annex 7. But, legally speaking,

this is not sufficient to introduce a new vehicle category into any of the Regulations. Contrary to what is normally assumed, each of the Regulations has to refer to this or a later version of R.E.3, Annex 7 before it covers the new vehicle category. After the introduction of L<sub>6</sub> and L<sub>7</sub> into R.E.3, Annex 7 in March 2005, all Regulations that should cover L<sub>6</sub> and L<sub>7</sub> have to be amended and must explicitly refer to the new R.E.3, Annex 7 (or even a later version). This cumbersome exercise tends to be neglected, probably because the modification of R.E.3 is deemed to be sufficient for extending the scope of the Regulations to the new vehicle categories (e.g. L<sub>6</sub> and L<sub>7</sub>). The consequence is a "de facto" unclear situation with regard to the scope of Regulations (in our example: covering "vehicles of category L"). Some type-approval authority agents will not check to what version of R.E.3, Annex 7 the applied Regulation refers to. Thus, they will issue type approvals covering L<sub>6</sub> and L<sub>7</sub> (or assume that a type approval given elsewhere covers L<sub>6</sub> and L<sub>7</sub>) though the applied Regulation has not yet referred to the new R.E.3, Annex 7. Only when the last Regulation has referred to the new R.E.3, Annex 7 (or even a later version), will the uncertainty disappear. The whole process of introduction of a new vehicle category might thus take many years and create a long limbo period.

The situation is even more complicated with regard to vehicle categories or sub-categories that have not been newly introduced but just modified. Whereas in practice only the new R.E.3, Annex 7 vehicle definitions are applied, the old vehicle definitions remain legally valid for those Regulations that have not yet referred to the new version of R.E.3, Annex 7. It is even possible that a set of three or more vehicle definitions may co-exist if different Regulations refer to multiple versions of R.E.3, Annex 7 that differ with regard to the same vehicle category.

The only effective remedy against the "de facto" uncertainty and frequent legal misinterpretation is, as suggested in this document, to fix vehicle categories and sub-categories in a cross-cutting way, in a legally binding instrument prevailing even over other Regulations under the 1958 Agreement. Such a legal instrument could be established under the 1958 Agreement as all Regulations are deemed to be annexed to the 1958 Agreement. It would be possible either to modify each of the Regulations or to establish a cross-cutting Regulation which would, in fact, be nothing less than a Regulation modifying all others in one stroke. At the end of the day, the Horizontal Regulation would create coherence between the real legal situation and the legal situation assumed by most users of Regulations.

However, first reactions from stakeholders have pointed to a couple of risks with regard to the initial concept of this document. First the question was raised whether a Contracting Party that has adopted the Horizontal Regulation could be overruled in a vote on an amendment to this Regulation. If so, the risk of accepting the Horizontal Regulation might be too high. But if the obligation is established to make such changes by consensus vote, progress might become difficult to achieve. Furthermore, according to others, the consensus vote should not be reintroduced into the 1958 Agreement.

A second concern was raised with regard to the legal feasibility: is it possible, within the 1958 Agreement, to establish a hierarchy of Regulations? The European Commission services take the view that this can be done, and not only by modifying the text of the 1958 Agreement itself but also by Regulations.



The third concern was that difficulties might arise when a Contracting Party withdraws from the Horizontal Regulation. The European Commission services share this concern. The only possible remedy would be to modify the 1958 Agreement in a way that accession to it automatically implies the acceptance of the Horizontal Regulation. Evidently, this would be a very far-reaching and cumbersome step.

In this document, the European Commission services take the concerns on board by permitting a dynamic reference on a case-by-case basis. The solution provided here would not have all the advantages of the initial concept, but permits a smooth transition to a system in which the particular Regulations will not have to be amended each time a vehicle category or a country code has been modified. In fact, WP.29 will, on the basis of the recommendation of the respective Working Party (GR), be able to refer to the Horizontal Regulation either at a certain point of time or by a dynamic reference. Whereas for country codes such a dynamic reference will certainly be inserted on the next occasion for updating the Regulations, it might take slightly more time to convince Contracting Parties that even a dynamic reference to vehicle categories can be made without risk and would provide benefits by making up-dating less of an effort.

Whatever solution is to be pursued, the Horizontal Regulation is a good approach. Within a few years, it will make hundreds of individual modifications of vehicle categories and country codes superfluous, thus keeping the 1958 Agreement manageable and giving time for more in-depth work on the real substance of the technical requirements. Its character as a Regulation avoids the legal pitfalls of a dynamic reference to a resolution that is not legally binding as such, but is only binding by concrete reference to a specific version of it. At the end of the day, there is no alternative to a Horizontal Regulation, whether it works in a cross-cutting way, as suggested by this document, or just by allowing dynamic references.

-----