

PROPOSAL FOR DRAFT AMENDMENTS TO REGULATION No. 100

A. PROPOSAL

UNIFORM PROVISIONS CONCERNING THE APPROVAL OF VEHICLES WITH REGARD TO PROTECTION AGAINST ELECTRIC SHOCK AND OF BATTERY ELECTRIC VEHICLES WITH REGARD TO SPECIFIC REQUIREMENTS FOR THE CONSTRUCTION, FUNCTIONAL SAFETY AND HYDROGEN EMISSIONS

ANNEXES

Annex 3 - **cancelled**

Annex 4 - Measurement of the insulation resistance **of a voltage class B Battery using the traction battery its own voltage** 15

1. SCOPE

The following prescriptions apply to safety requirements with respect to **protection against electric shock of all vehicles of categories M, N and O with a maximum design speed exceeding 25 km/h with the exception of vehicle components type approved according to another regulation and with respect to specific requirements for the construction, functional safety and hydrogen emissions of all battery electric road vehicles of categories M and N with a maximum design speed exceeding 25 km/h.**

2. DEFINITIONS

2.10. **"~~Coupling system~~ Connecting system"** means all the parts used to connect the vehicle to an external electric power supply (alternative or direct current supply).

2.26. **"Barrier"** means a part providing protection against direct contact from any usual direction of access

2.27. **"Enclosure"** means a part providing protection of equipment against certain external influences and against direct contact from any direction

2.28. **"Voltage class A electric circuit"** means an electric circuit with a maximum working voltage of ≤ 25 V A.C. or ≤ 60 V D.C.

2.29. **"Voltage class B electric circuit"** means an electric circuit with a maximum working voltage of (> 25 and ≤ 1000) V A.C. or (> 60 and ≤ 1500) V D.C.

2.30. **"Basic insulation"** means an isolation applied to live parts necessary to provide protection against direct contact (in a no-fault condition)

- 2.31. **"Supplementary insulation"** means an independent insulation applied to basic insulation, in order to provide protection against electric shock in the event of a failure of the basic insulation
- 2.32. **"Double insulation"** means insulation which comprising both basic and supplementary insulation
- 2.33. **"Reinforced insulation"** means insulation system applied to live parts which provides protection against direct contact equivalent to double insulation.
- 2.34. **"Component of the system"** means a component belonging to the electrical traction system as described within the scope of this regulation.

5. SPECIFICATIONS AND TESTS

5.1.2. Protection against electric shock

5.1.2.1. General

~~5.1.2.1. Protection against direct contact with live parts of the power train:~~

~~5.1.2.1.1. If the working voltage of the electric circuit is lower than 60 volts DC or 25 volts AC, no requirements are necessary.~~

~~5.1.2.1.2. Direct contact with live parts of the electrical power train whose maximum voltage is at least 60 volts DC or 25 volts AC shall be prevented either by insulation or by the use of covers, protection grilles, perforated metal sheets, etc. These protections shall be reliably secured and shall be mechanically resistant. They shall not be able to be opened, disassembled or removed without the use of tools.~~

~~5.1.2.1.3. In passenger and load compartments live parts in any case shall be protected by enclosures having a protection degree of at least IPXXD.~~

~~5.1.2.1.4. Enclosures in other areas of the vehicle shall have a protection degree of at least IPXXB.~~

~~5.1.2.1.5. In the engine compartment the access to live parts shall only be possible with voluntary action.~~

~~5.1.2.1.6. After opening the cover, the access to the parts of the coupling system shall be protected with IPXXB protection.~~

~~5.1.2.1.7. Protection degrees IPXXB and IPXXD are related respectively, to the contact of a jointed test finger and a test wire with hazardous parts (Annex 3).~~

5.1.2.1.1. Protection against electric shock means either preventing a person to simultaneously come into contact with two or more live parts having a voltage between them or to limit the current and its duration in case of such contact (max. 10 mA are continuously allowed, which corresponds to 100 Ω/V min. resistance).

- 5.1.2.1.2. Protection against electric shock shall be comprised of**
- **Basic protection (protection against direct contact with live parts under normal (fault-free) conditions) and**
 - **Protection under any first failure condition with respect to electric shock**
- 5.1.2.1.3. The protection measures as described in 5.1.2.2., 5.1.2.3. and 5.1.2.4. are required only for voltage class B electric circuits.**
- 5.1.2.1.4. The protection measures can be different for the various live parts of one circuit.**
- 5.1.2.1.5. Voltage class B circuits isolated from the vehicle electric chassis have to pass the Insulation resistance test according to ISO 23273-3:2006, 8.2.2
Battery powered systems can be tested alternatively according to Annex 4.**
- 5.1.2.1.6. Barriers/Enclosures accessible directly shall comply with the requirements of ISO 20653:2006 for IPXXD, if when removed expose live parts of voltage class B circuits.**
- 5.1.2.1.7. Each component of the system carrying voltages of class B has to fulfill the requirements of clearance and creepage distances according to ISO 23273:2006, 8.2.5.1**
- 5.1.2.1.8. Alternatively to the requirements in 5.1.2.1.7 each component of the system has to pass a high voltage withstand test according to ISO 23273:2006, 8.2.5.2**
- 5.1.2.1.9. Specifications for potential equalization: Connected parts have to pass the continuity test according to ISO 23273-3:2006, 8.3.3.**
- 5.1.2.2. Basic protection measures**
- 5.1.2.2.1. Persons shall be protected against direct contact to live parts by either one or both of**
- **Basic insulation of live parts**
 - **Barriers/enclosures, preventing access to live parts.**
- The barriers/enclosures may be electrically conductive or non-conductive.**
- NOTE: Special attention shall be taken to the protection of basic insulation of live parts in passenger and loading compartments.**
- 5.1.2.2.2. In any case exposed conductive parts, including conductive barriers/enclosures shall be connected to the electric chassis potential equalization. This potential equalization is obtained by connecting the exposed conductive parts together either by a protective conductor, e.g. wire, ground truss, or directly by the vehicle metallic chassis. Two exposed conductive parts welded together are considered as having no discontinuity points. If there is some discontinuity, this point shall be by-passed by potential equalization.**
- 5.1.2.3. First failure protection for circuits isolated from the vehicle electric chassis**
- 5.1.2.3.1. Sufficient protection is provided with any of the basic protection measures if the system of any circuit meets the 100 Ω/V minimum resistance requirement.**

5.1.2.3.2. If the 100 Ω /V minimum resistance requirement cannot be maintained then protection under any first failure condition shall be achieved by one or more of

- **double insulation or reinforced insulation**
- **an additional layer of barriers/enclosures over the basic protection measures as supplementary insulation**
- **monitoring periodically or continuously the resistance between the chassis and the live parts during operation of the vehicle. An appropriate warning shall be provided if loss of resistance is detected.**
- **providing an appropriate leakage current detection and shut-down system. The affected circuit shall be shut off such that permanent or severe injury does not occur, considering the expected type and degree of human contact and the operational state of the vehicle.**

5.1.2.4. Basic and first failure protection for circuits connected to the vehicle electric chassis

Protection shall be provided by any of the following:

- **double, or reinforced insulation**
- **an additional layer of barriers/enclosures over the basic class B protection. If a conductive barrier/enclosure is used for basic protection, then the additional layer of barriers/enclosures shall be non-conductive.**

5.1.2.5. Alternative approach to protection measures against electric shock

5.1.2.5.1. Alternatively to the selection of the protection measures as prescribed above, the following approach may be applied by the vehicle manufacturer to establish sufficient protection for persons against electric shock. This approach may also be applied to develop alternative protection measures more specific to the conditions of a given vehicle design in relation to the voltage class B circuits.

5.1.2.5.2. The vehicle manufacturer shall conduct an appropriate hazard analysis in respect to electric shock and establish a set of measures which give sufficient protection against electric shock.

This analysis may use a FMEA (failure mode and effect analysis), a FTA (fault tree analysis), or another appropriate method and shall consider normal (fault free) and any first failure conditions relevant for electric shock hazards.

5.1.2.5.3. This approach can also determine the requirements for components and systems being integrated into the vehicle during assembly as units, so that such components and systems can be designed, manufactured and tested accordingly.

5.1.2.6. Vehicle markings

~~**Protection covers of live parts described in Paragraph 5.1.2.1.2. shall be marked by a symbol as described in Annex 5.**~~

~~**5.1.2.2. Protection against indirect contacts with exposed conductive parts of the power train.**~~

~~**5.1.2.2.1. If the working voltage of the electric circuit is lower than 60 volts DC or 25 volts AC, no requirements are necessary;**~~

~~**5.1.2.2.2. The design, installation, and manufacture of electric material shall be such that insulation failures are avoided;**~~

~~5.1.2.2.3. Protection against indirect contacts shall be ensured by using insulation and additionally, the exposed conductive parts of the on-board equipment shall be galvanically connected together. This potential equalisation is obtained by connecting the exposed conductive parts together either by a protective conductor, e.g. wire, ground truss, or directly by the vehicle metallic chassis. Two exposed conductive parts welded together are considered as having no discontinuity points. If there is some discontinuity, this point shall be by-passed by potential equalisation.~~

~~5.1.2.3. Insulation Resistance~~

~~5.1.2.3.1. The insulation resistance measurement is performed after maintaining the vehicle for a conditioning time of 8 hours with the following conditions:~~

~~Temperature: $23 \pm 5^{\circ}\text{C}$ Humidity: $90\% \pm 10/5\%$.~~

~~5.1.2.3.2. Using a measuring DC voltage equal to the nominal voltage of the traction battery, insulation resistances between any exposed conductive part and each polarity of the battery shall have a minimum value of $500 \Omega/\text{V}$ of the nominal voltage (Annex 4 contains an example of how this test may be conducted).~~

~~5.1.2.3.3. Resistance of the Protective Conductor:~~

~~The potential equalisation resistance between any two exposed conductive parts shall be lower than 0.1Ω . This test shall be performed by a current of at least 0.2 A .~~

~~5.1.2.4. Connection of the vehicle to the mains network:~~

~~5.1.2.4.1. In no case the vehicle shall be capable to move by its own means when it is galvanically connected to an energy supply network or to an off-board charger;~~

~~5.1.2.4.2. The components used when charging the battery from an external source shall allow the charging current to be cut in case of disconnection without physical damage;~~

~~5.1.2.4.3. The coupling system parts likely to be live shall be protected against any direct contact in all operating conditions;~~

~~5.1.2.4.4. All exposed conductive parts shall be electrically linked through a conducting wire plugged to earth when charging.~~

~~5.1.2.6.1. The symbol as described in annex 5 shall appear on barriers and enclosures, which, when removed expose live parts of class B circuits. In case of the engine compartment it is sufficient that the symbol appears after opening the hood.~~

~~5.1.2.6.2. Harnesses containing voltage class B cables shall be visually identified by a permanent orange harness covering material~~

~~5.1.2.7. Connection of the vehicle to an off-board electric power supply~~

~~5.1.2.7.1. If a voltage class B electric network of the vehicle or sections of it can be galvanically connected to an off-board electric power supply (e.g. for the supply of electric energy during standstill of the vehicle) or to an off-board charger (to charge a traction battery) protection of persons against electric shock shall be provided by the following means:~~

5.1.2.7.1.1. The connecting system parts likely to be live during the connection period shall be protected against any direct contact in all operating conditions;

5.1.2.7.1.2. The chassis of the vehicle (including all exposed conductive parts) shall be connected to earth by means of the connector. The connector shall be such that connection to earth is established before the exterior voltage is applied and that it is interrupted after the exterior voltage is switched off.

5.1.2.7.1.3. A fault current protection device with a nominal cut –off current not exceeding 30 mA shall be provided between the connector and the off –board electric network.

5.1.2.7.2. The vehicle shall not be capable to move by its own means when it is galvanically connected to an off-board electric network or to an off board charger (to charge a traction battery, if any).

5.1.2.7.3. The components of the connecting system shall allow the current to be cut in case of disconnection without physical damage;

5.2. Functional safety requirements of battery electric road vehicles

5.2.2. Running and stopping conditions:

5.2.2.4. ~~When leaving the vehicle, the driver~~ If the vehicle does not move at creeping speed as soon as "driving active" is engaged , the driver intending to leave the vehicle shall be informed by an obvious signal (e.g. optical or audible signal) if the drive train is still in the active driving possible mode.

Annex 1 - COMMUNICATION

Concerning : ^{2/} APPROVAL GRANTED,
APPROVAL EXTENDED,
APPROVAL REFUSED,
APPROVAL WITHDRAWN,
APPROVAL DEFINITELY DISCONTINUED,

of a ~~battery electric~~ road vehicle pursuant to Regulation No. 100

Annex 2 - ARRANGEMENTS OF APPROVAL MARKS

Model A

The above approval mark affixed to a vehicle shows that the ~~battery electric~~ road vehicle type concerned has been approved in the Netherlands (E4), pursuant to Regulation No. 100, and under the approval number 002492. The first two digits of the approval number indicate that the approval was granted in accordance with the requirements of Regulation No. 100 in its original form.

Model B

The above approval mark affixed to a vehicle shows that the ~~battery electric~~ road vehicle concerned has been approved in the Netherlands (E4) pursuant to Regulations Nos. 100 and 42 */. The first two digits of the approval numbers indicate that, at the dates when respective approvals were granted, both Regulations Nos. 100 and 42 were in their original form.

Annex 4 - MEASUREMENT OF THE INSULATION RESISTANCE OF A VOLTAGE CLASS B BATTERY USING ~~THE TRACTION BATTERY~~ ITS OWN VOLTAGE

1. DESCRIPTION OF THE TEST METHOD

~~The traction battery shall be fully charged.~~

The voltmeter used in this test shall measure DC values and have an internal resistance greater than 10 M Ω .

Throughout the test, the traction battery shall have an open circuit voltage greater than or equal to its nominal value.

The measurements shall be performed in three steps, as shown below.

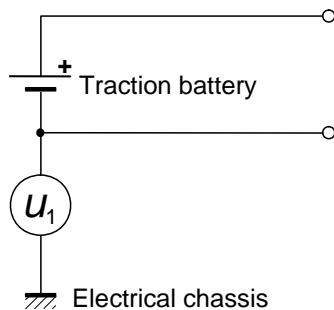

Step 1: measurement of U_1

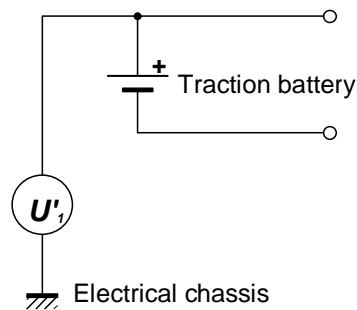

Step 2: measurement of U'_1

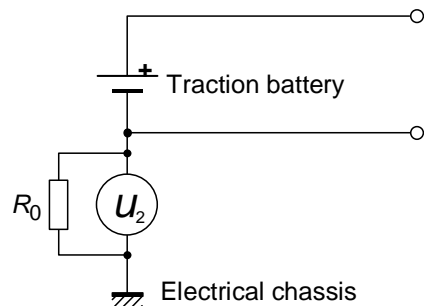

Step 3: measurement of U_2 (if $U_1 > U'_1$)

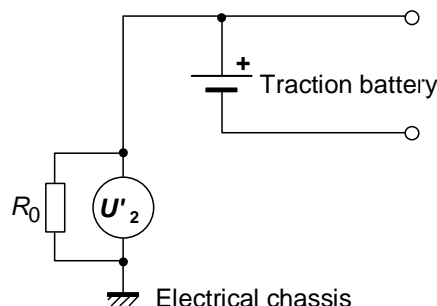

Step 3: measurement of U'_2 (if $U_1 < U'_1$)

NOTE R_0 is a standard resistance of between 100 Ω/V and 500 Ω/V (referred to the nominal voltage of the traction battery)

The value of the insulation R_i shall be calculated by

$$R_i = \frac{(U_1 - U_2)}{U_2} \bullet R_0$$

$$R_i = \frac{(U'_1 - U'_2)}{U'_2} \bullet R_0$$

Annex 6 - ESSENTIAL CHARACTERISTICS OF ~~ELECTRIC~~ ROAD VEHICLES OR SYSTEMS

- 8. Protection against Electric Shock**
- 8.1. Description of the Electrical System**
- 8.2. Description of the Protection Concept**

B. JUSTIFICATION

Due to the development of alternative propulsion systems the requirements for electric shock does not only apply to battery electric vehicle. Furthermore these requirements should be extended to all relevant vehicles and parts.

The requirements of electric shock are intended to be valid only for those systems or parts, which are not covered by other Regulations, e.g. gas discharge light according to ECE-R 98 is not addressed. The amendments are updated based upon international requirements according ISO 23273 and 20653 which could be seen as state of the art. The safety requirements are applicable only for the relevant parts, systems or vehicles, which have voltages above 25 V A.C. or 60 V D.C. .