



**Economic and Social
Council**

Distr.
GENERAL

TRANS/WP.29/2005/88
2 August 2005

Original: ENGLISH

ECONOMIC COMMISSION FOR EUROPE

INLAND TRANSPORT COMMITTEE

World Forum for Harmonization of Vehicle Regulations (WP.29)
(One-hundred-and-thirty-seventh session, 15-18 November 2005,
agenda item 5.3.4.)

PROPOSAL FOR NEW REGULATION
CONCERNING THE APPROVAL OF PARTITIONING SYSTEMS TO PROTECT
PASSENGERS AGAINST DISPLACED LUGGAGE, SUPPLIED AS NON ORIGINAL
VEHICLE EQUIPMENT

Transmitted by the Working Party on Passive Safety (GRSP)

Note: The text reproduced below was adopted by GRSP at its thirty-seventh session and is transmitted for consideration to WP.29 and AC.1. (TRANS/WP.29/GRSP/37, para. 31). It is based on documents TRANS/WP.29/GRSP/2004/19 and Amend.1, as amended (TRANS/WP.29/GRSP/37, Annex 4).

This document is a working document circulated for discussion and comments. The use of this document for other purposes is the entire responsibility of the user.

Documents are also available via the INTERNET:

<http://www.unece.org/trans/main/welcwp29.htm>

UNIFORM PROVISIONS CONCERNING THE APPROVAL OF PARTITIONING SYSTEMS
TO PROTECT PASSENGERS AGAINST DISPLACED LUGGAGE, SUPPLIED AS
NON ORIGINAL VEHICLE EQUIPMENT

1. SCOPE

This Regulation applies to devices intended to protect the occupants from the danger resulting from the displacement of luggage into the vehicle seating areas in a frontal impact, of vehicles of category M₁ ^{1/}, supplied as non original vehicle equipment.

2. DEFINITIONS

For the purposes of this Regulation

2.1. "Partitioning System" means parts or devices which in addition to the seat backs, are intended to protect occupants from displaced luggage.

2.2. "Non original vehicle equipment" means a partitioning system which is not offered by the vehicle manufacturer as standard or optional equipment for the vehicle(s) application(s) prescribed by the partitioning system manufacturer.

2.3. "Approval of a partitioning system" means the approval of a type of partitioning system with regard to the strength, design and characteristics of the partitioning systems.

2.4. "Type of partitioning system" means a category of partitioning system which does not differ in such essential respects as:

2.4.1. the structure, shape, dimensions, materials and the mass of the partitioning system, although the system may differ in covering and colour;

2.4.2. the type and dimensions of the adjustment, locking and attachment systems of the partitioning system;

2.4.3. the specific vehicle application(s) prescribed by the applicant for the approval.

2.5. "Seat" see paragraphs 2.3. and 2.4. of Regulation No. 17.

2.6. "Anchorage" means the system by which the partitioning system is secured to the vehicle structure, including the affected parts of the vehicle structure;

2.7. "Adjustment system" means the device by which the partitioning system or its parts can be adjusted to a position suited to the installation as recommended by the applicant for the approval in the prescribed vehicle(s) and position(s) within said vehicle(s).

^{1/} As defined in Annex 7 to the Consolidated Resolution on the Construction of Vehicles (R.E.3)
TRANS/WP.29/78/Rev.1/Amend.2)

2.8. "Locking system" means a device ensuring that the partitioning system and its parts are maintained in the position of use.

2.9. "Intermediate structures" means vehicle components to which the partitioning system is attached to the prescribed vehicle(s) which do not constitute the anchorages.

3. APPLICATION FOR APPROVAL

3.1. The application for approval of a type of partitioning system shall be submitted by the holder of the trade mark or by his duly accredited representative.

3.2. It shall be accompanied by:

3.2.1. a technical description of the partitioning system specifying the fabrics and rigid parts used and accompanied by drawings of the parts making up the partitioning system. The drawings must show the position intended for the approval number and the additional symbol(s) in relation to the circle of the approval mark.

The description shall specify the vehicle type(s) for which the partition system type have applications and the position(s) of attachment within the vehicle(s).

3.2.2. a drawing of the intended partitioning system installation(s) in vehicle type(s) and partitioning system installation position(s) including sufficient dimensions to facilitate the positioning of the test blocks, anchorage points to the vehicle structure, intermediate structures, seats and trim panels as may be required in Annex 3, paragraph 2.

3.2.3. three samples of the partitioning system type, one of which is for reference purposes.

3.2.4. samples of materials used in quantities required by the technical service conducting the approval tests.

3.2.5. samples of seats, intermediate structures and trim panels required for the tests prescribed in Annex 3, paragraphs 2.4. and 2.6.

3.2.6. The technical service conducting the type-approval tests shall be entitled to request further samples.

4. MARKINGS

The samples of a partition system type submitted for approval in conformity with the provisions of paragraph 3. above shall be clearly and indelibly marked with the manufacturer's name, initials or trade name or mark.

5. APPROVAL

5.1. If the samples of a type of partitioning system which are submitted in conformity with the provisions of paragraph 3. meet the requirements of paragraph 6. below, approval shall be granted.

- 5.2. An approval number shall be assigned to each type approved. Its first two digits (at present 00 corresponding to the 00 series of amendments) shall indicate the series of amendments incorporating the most recent major technical amendments made to the Regulation at the time of issue of the approval. The same Contracting Party may not assign the same number to another type of partitioning system.
- 5.3. Notice of approval or of extension or refusal of approval of a type of partitioning system, pursuant to this Regulation, shall be communicated to the Parties to the 1958 Agreement which apply this Regulation by means of a form conforming to the model in Annex 1 to the Regulation.
- 5.4. There shall be affixed, conspicuously and in a readily accessible place specified on the approval form, to every partitioning system confirming to a type approved under this Regulation, an international approval mark consisting of:
 - 5.4.1. a circle surrounding the letter "E" followed by the distinguishing number of the country which has granted approval; 2/
 - 5.4.2. the approval number to the right of the circle prescribed in paragraph 5.4.1.
- 5.5. The approval mark shall be clearly legible and be indelible.
- 5.6. The approval mark shall be affixed on the partitioning system by the manufacturer.
- 5.7. Examples of arrangements of approval marks are given in Annex 2 to this Regulation.

2/ 1 for Germany, 2 for France, 3 for Italy, 4 for the Netherlands, 5 for Sweden, 6 for Belgium, 7 for Hungary, 8 for the Czech Republic, 9 for Spain, 10 for Yugoslavia, 11 for the United Kingdom, 12 for Austria, 13 for Luxembourg, 14 for Switzerland, 15 (vacant), 16 for Norway, 17 for Finland, 18 for Denmark, 19 for Romania, 20 for Poland, 21 for Portugal, 22 for the Russian Federation, 23 for Greece, 24 for Ireland, 25 for Croatia, 26 for Slovenia, 27 for Slovakia, 28 for Belarus, 29 for Estonia, 30 (vacant), 31 for Bosnia and Herzegovina, 32 for Latvia, 33 (vacant), 34 for Bulgaria, 35 (vacant), 36 for Lithuania, 37 for Turkey, 38 (vacant), 39 for Azerbaijan, 40 for The former Yugoslav Republic of Macedonia, 41 (vacant), 42 for the European Community (Approvals are granted by its Member States using their respective ECE symbol), 43 for Japan, 44 (vacant), 45 for Australia, 46 for Ukraine, 47 for South Africa, 48 for New Zealand, 49 for Cyprus, 50 for Malta and 51 for the Republic of Korea. Subsequent numbers shall be assigned to other countries in the chronological order in which they ratify or accede to the Agreement Concerning the Adoption of Uniform Technical Prescriptions for Wheeled Vehicles, Equipment and Parts which can be Fitted and/or be Used on Wheeled Vehicles and the Conditions for Reciprocal Recognition of Approvals Granted on the Basis of these Prescriptions, and the numbers thus assigned shall be communicated by the Secretary-General of the United Nations to the Contracting Parties to the Agreement.

6. REQUIREMENTS

6.1. Tests

The partitioning systems shall be tested in accordance with the test procedures described in Annex 3.

Partitioning systems which according to paragraph 3.2.1. may be used in more than one vehicle or may be used in more than one prescribed position within a specified vehicle must conform to the tests prescribed in Annex 3 in all prescribed vehicles and positions.

6.2. Specifications

6.2.1. Partitioning systems, when tested in accordance with the requirements of paragraph 6.1. must withstand sufficient forces to demonstrate their ability to protect occupants from displaced luggage during frontal impacts.

The requirement is deemed to be met if the forward displacement of the test block or blocks is less than 300 mm beyond the plane Y-Y , shown in Annex 3, Appendix 3, which is perpendicular to the longitudinal axis of the vehicle prescribed installation formed by the rear edge of the seat backs immediately in front of the partitioning system adjusted in accordance with Annex 3, paragraph 2.7., unless the manufacturer can prove to the satisfaction of the technical service responsible for conducting the approval tests that forward displacement exceeding 300 mm would not increase the risk of serious injury to occupants during a frontal impact.

The partitioning system should not break away from any of its attachment points. After the test no sharp edges of rigid parts of the partitioning system may be contactable that may lead to injury to vehicle occupants.

6.2.2. The assembled partitioning system shall not contain any dangerous roughness or sharp edges likely to increase the risk of serious injury to occupants. Rigid components of the partitioning system or intermediate structures contactable by occupants during an impact with material of greater than 50 Shore A hardness must have surfaces that terminate in rounded edges the radius of curvature being not less than 3.2 mm.

7. CONFORMITY OF PRODUCTION

The conformity of production procedures shall comply with those set out in the Agreement, Appendix 2 (E/ECE/324-E/ECE/TRANS/505/Rev.2), with the following requirements:

7.1. Every partitioning system approved pursuant to this Regulation shall be so manufactured as to conform to the type approved by meeting the requirements set out in paragraph 6. above.

7.2. The competent authority which granted type approval may at any time verify the conformity control methods applied for each production unit. The normal frequency of

these verifications shall be once a year. The authority may also carry out random checks on serially-manufactured partitioning systems in respect to the requirements set out in paragraph 6. above.

8. PENALTIES FOR NON-CONFORMITY OF PRODUCTION

8.1. The approval granted in respect of a partitioning system type pursuant to this Regulation may be withdrawn if the requirements laid down in paragraph 6. above are not complied with or if the partitioning system fails in the tests prescribed in paragraph 6. above.

8.2. If a Contracting Party to the Agreement applying this Regulation withdraws an approval it has previously granted, it shall forthwith so notify the other Contracting Parties applying this Regulation by means of a communication form conforming to the model in Annex 1 to this Regulation.

9. MODIFICATIONS OF THE TYPE OF PARTITIONING SYSTEM

9.1. Every modification of the type of partitioning system or the vehicle(s) and installation position(s) to which it is applicable shall be notified to the administrative department which approved the partitioning system type. The department may then either:

9.1.1. consider that the modifications made are unlikely to have an appreciable adverse effect, and that in any event the partitioning system still complies with the requirements; or

9.1.2. consider that the modifications are sufficiently unimportant for the results specified in paragraph 6. above to be verified by technical information supplied by the manufacturer; or

9.1.3. require a further report from the technical service responsible for conducting the tests.

9.2. Confirmation or refusal of approval, specifying the modifications, shall be communicated to the Parties to the Agreement applying this Regulation by means of the procedure laid down in paragraph 5.3. above.

9.3. The competent authority issuing the extension of approval shall assign a series number for such an extension and inform thereof the other Parties to the 1958 Agreement applying this Regulation by means of a communication form conforming to the model in Annex 1 to this Regulation.

10. PRODUCTION DEFINITELY DISCONTINUED

If the holder of the approval completely ceases to manufacture a device approved in accordance with this Regulation, he shall so inform the authority which granted the approval. Upon receiving the relevant communication that authority shall inform thereof the other Parties to the 1958 Agreement applying this Regulation by means of a communication form conforming to the model in Annex 1 to this Regulation.

11. INSTRUCTIONS FOR USE

Every partitioning system shall be accompanied by instructions of the following content or kind in the language or languages of the country in which it is to be placed on sale.

- 11.1. Installation instructions which specify for which vehicle type(s) the assembly is suitable and the correct method(s) of attachment(s) of the assembly to the vehicles.
- 11.2. User instructions which specify the instructions to ensure the user obtains the maximum benefit from the partitioning system. In these instructions reference shall be made to:
- (a) the importance of using the partitioning system on all journeys where luggage is transported,
 - (b) the correct adjustment and positioning of the partitioning system,
 - (c) method of operating any adjustment and/or locking system incorporated in the partitioning system,
 - (d) the recommended placement of luggage and its restraint within the luggage compartment of the vehicle type(s) for which the partitioning system is intended,
 - (e) the need to replace partitioning systems that are damaged.

12. NAMES AND ADDRESSES OF TECHNICAL SERVICES RESPONSIBLE FOR CONDUCTING APPROVAL TESTS AND OF ADMINISTRATIVE DEPARTMENTS

The Contracting Parties to the Agreement applying this Regulation shall communicate to the United Nations Secretariat the names and addresses of the technical services responsible for conducting approval tests and of the administrative departments which grant approval and to which forms certifying approval or extension or refusal or withdrawal of approval, issued in other countries, are to be sent.

Annex 1

COMMUNICATION

(maximum format: A4 (210 x 297 mm))

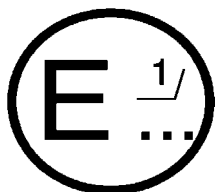

issued by: Name of administration:

.....
.....
.....

concerning: 2/

- APPROVAL GRANTED
- APPROVAL EXTENDED
- APPROVAL REFUSED
- APPROVAL WITHDRAWN
- PRODUCTION DEFINITELY DISCONTINUED

of a type of partitioning system pursuant to Regulation No. xx

Approval No:

Extension No:

1. Trade name or mark of the partitioning system:
2. Specific for Vehicle type(s):
3. Manufacturer's name and address:
4. If applicable, name and address of the manufacturer's representative:
.....
5. Description of the partition system:
6. Description of the adjustment and locking system of the partitioning system and of its parts:
.....
7. Description of the position(s) within the vehicle type(s) of the partitioning system:
.....

8. Description of anchorages and anchorage materials supplied with the partitioning system:
.....
9. Partitioning system submitted for approval on:
10. Technical service responsible for conducting approval tests:
11. Date of report issued by that service:
12. No. of report issued by that service:
13. Remarks:
14. Approval is granted/refused/extended/withdrawn 2/
15. Reason(s) of extension (if applicable):
16. Position of approval mark on the partitioning system:
17. Place:
18. Date:
19. Signature:
20. The following documents, bearing the approval number shown above, are annexed to this communication:
 - drawings, diagrams and plans of the partitioning system, its anchorages on the vehicle, the adjustment systems of the partitioning system and its parts, and its locking devices;
 - photographs of the partitioning system, its anchorages, the adjustment systems and its parts, and its locking devices.

1/ Distinguishing number of the country which has granted/extended/refused/withdrawn approval (see approval provisions in the Regulation).

2/ Strike out what does not apply.

Annex 2

ARRANGEMENTS OF APPROVAL MARKS
(see paragraph 5.4. of this Regulation)

Partitioning system

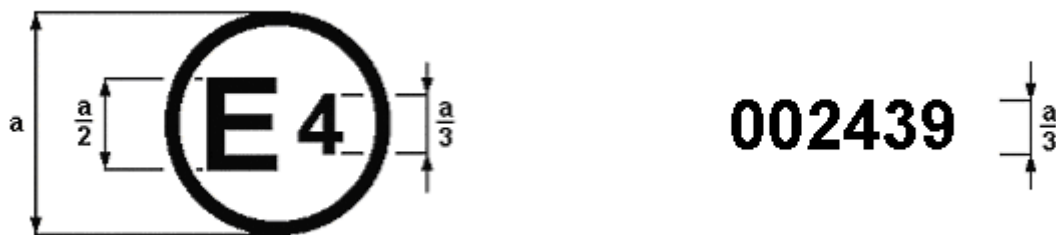

$a = 8 \text{ mm min.}$

The above approval mark when affixed to a partitioning system shows that the type of partitioning system concerned, with regard to the strength, has been approved in the Netherlands (E4) pursuant to Regulation No. xx, under the approval number 002439. The first two digits of the approval number indicate that the Regulation is not amended.

Note: The approval number and additional symbol(s) must be placed close to the circle and either above or below the "E" or to the left or right of that letter. The digits of the approval number must be on the same side of the "E" and orientated in the same direction. The use of roman numerals as approval numbers should be avoided so as to prevent confusion with other symbols.

Annex 3

TEST PROCEDURE FOR DEVICES INTENDED TO PROTECT THE OCCUPANTS
AGAINST DISPLACEMENT OF LUGGAGE

1. Test blocks

Rigid blocks, with the centre of inertia in the geometric centre.

Type 1

Dimensions: 300 mm x 300 mm x 300 mm

All edges and corners rounded to 20 mm

Mass: 18 kg

Type 2

Dimensions: 500 mm x 350 mm x 125 mm

All edges and corners rounded to 20 mm

Mass: 10 kg

2. Test preparation

- 2.1. The partitioning system must be attached to a rigid frame with the attachment hardware supplied by the manufacturer. The rigid frame must incorporate a rigid horizontal plane "E" (see Annex 4) which replicates the general level of the vehicle luggage area floor. The attachment points A, B, C and D should replicate the geometry of the intended vehicle anchorage points as specified in paragraph 3.2.2. in the application for approval, measured from the datum plane "E".

If there are different installation locations recommended by the applicant for approval, the worst case position has to be chosen in agreement with the technical service.

All attachment straps, intermediate structures and hardware, etc. should be fitted in accordance with the instructions of the applicant for the approval.

- 2.2. The effective floor of the test configuration described in paragraph 2.1. should replicate the level in relationship to anchorage points A, B, C and D in accordance to the relationship of the intended vehicle anchorage points and the effective load floor of the proposed installation specified in paragraph 3.2.2. of this Regulation.

- 2.3. Two type 1 test blocks shall be placed on the surface "E" of the rigid frame.

- 2.3.1. In order to determine the location of the test blocks in the longitudinal direction, they shall first be positioned such that their front side contacts the partitioning system and that their lower surface rest on the horizontal plane "E" of the rigid frame. They shall then be moved backwards and parallel to the longitudinal median plane of the rigid a horizontal distance of 200 mm. In this position they have to be secured against any backward movement. If in the prescribed vehicle installation described in paragraph 3.2.2. of this Regulation, it would not be possible to move the two type 1 blocks the distance of 200 mm they should be moved to the limit of their travel in the prescribed vehicle installation. The distance between the longitudinal median plane of the rigid frame and the inward facing side of each test block shall be 25 mm to obtain a distance of 50 mm between both test blocks. See Appendix 2 to this annex.
- 2.3.2. Proposed vehicle installations as described in paragraph 3.2.2. of this Regulation behind which the type 1 test blocks cannot be installed are to be tested in their absence.
- 2.3.3. The rigid frame shall be fitted with a fixed raised test floor having a load surface that locates the centre of gravity of a type 2 test block centrally between the top edge of the seat back located directly forward of the partitioning system, (without taking into account the head restraints) and the bottom edge of the head lining, directly above this point (X-X in Annex 3, Appendix 2) as defined in paragraph 3.2.2. of this Regulation type 2 test block is to be placed on the raised test floor with its largest surface (500 mm x 350 mm) on the load surface centrally in relationship to the longitudinal axis of the rigid frame and with its surface 500 mm x 125 mm to the front and in direct contact with the partitioning system. Partitioning system installations behind which the type 2 test block cannot be installed are to be tested without its presence. See Appendix 2 to this annex.
- 2.4. If the attachment points of the partitioning system are attached to an intermediate structure in its intended installation position (such as a seatback, side trim, etc.), these interceding components should be attached to the rigid frame with the manufacturer's specified attachment parts.
- 2.5. If the partitioning system, in its prescribed installation within the rigid test frame, has no structure which extends to within 400 mm of the rigid horizontal plane "E" (Annex 4), the test may be conducted in the absence of the type 1 test blocks.
- 2.6. If vehicle components such as body sheet metalwork, seats, trim panels, etc., will affect the partitioning systems' forward displacement, these components may be attached to the rigid frame prescribed in paragraph 2.1., but should be attached to said frame in the position which most closely represents their vehicle installed position relative to the partitioning system as prescribed in paragraph 3.2.2. of this Regulation at the request of the manufacturer. With the exception of longitudinally adjustable occupant seats, where these positions are adjustable within the vehicle (such as rear seat backs), they must be positioned such as to represent their adjusted position which would offer the lowest influence on partition system forward motion.

2.7. Where the forward displacement of the partitioning system is restrained by a longitudinally adjustable seat assembly these seats, if affixed to the rigid frame prescribed in paragraph 2.1.1., at the manufacturers request, should be positioned within 10 mm of their lowest, rearmost position and the seat back, if adjustable, should be adjusted to as near as possible to 25°. Head restraints, if fitted, must be adjusted to their lowest position.

3. Test performance

The test frame and its attachments prescribed in paragraphs 2.1., 2.2., 2.3.1., 2.3.3., 2.4., 2.6. and 2.7. shall be attached securely to a test sled which shall be decelerated from an initial velocity to standstill such that the sled and its attached frame is subjected to deceleration falling within the bounds of the corridor specified graphically in Appendix 1 to Annex 3.

Annex 3 – Appendix 1

SLED DECELERATION CORRIDOR AS A FUNCTION OF TIME
(Frontal impact)

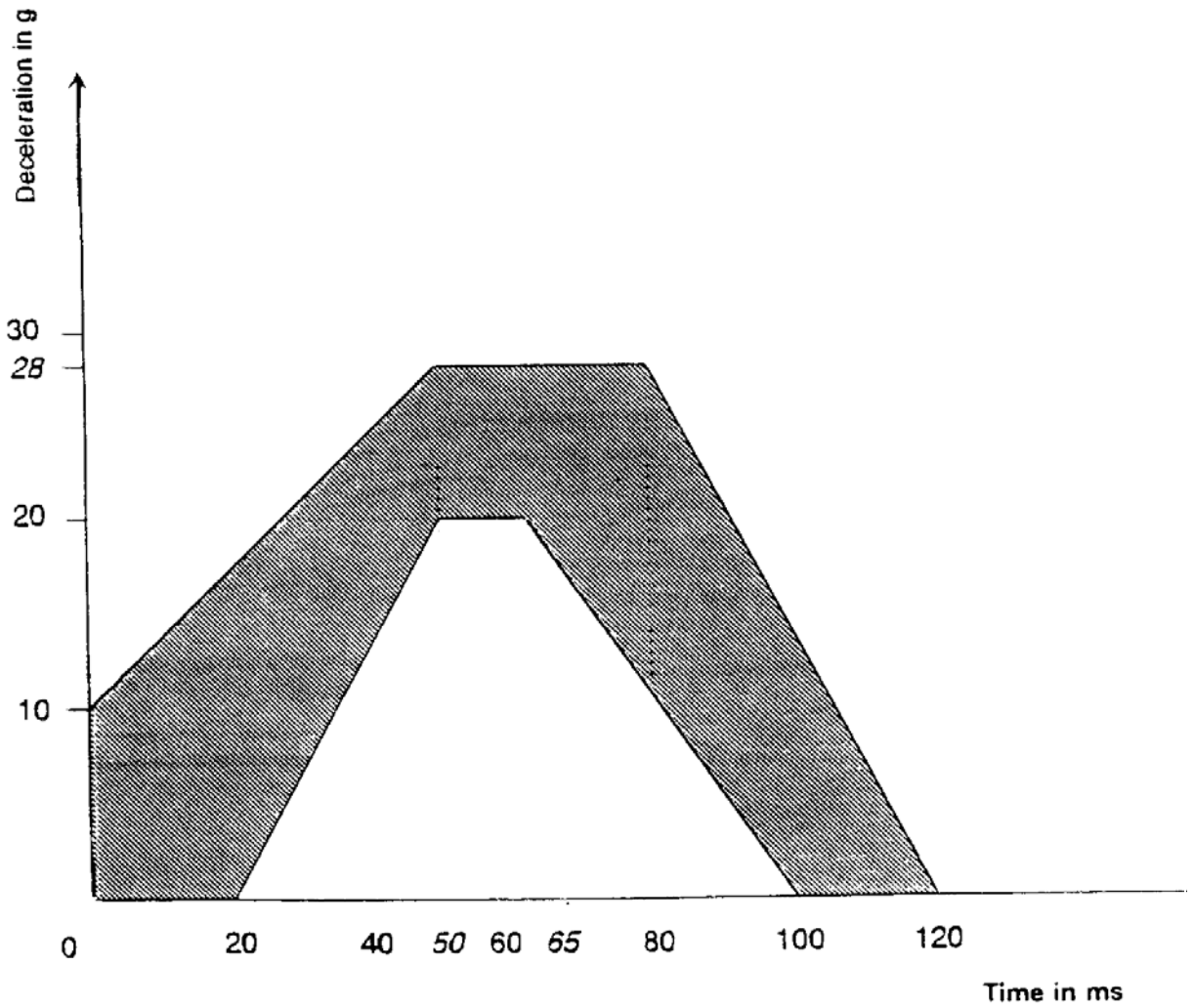

Annex 3 – Appendix 2

POSITION OF TYPE 1 AND TYPE 2 TEST BLOCKS
IN RELATIONSHIP TO THE TEST FRAME

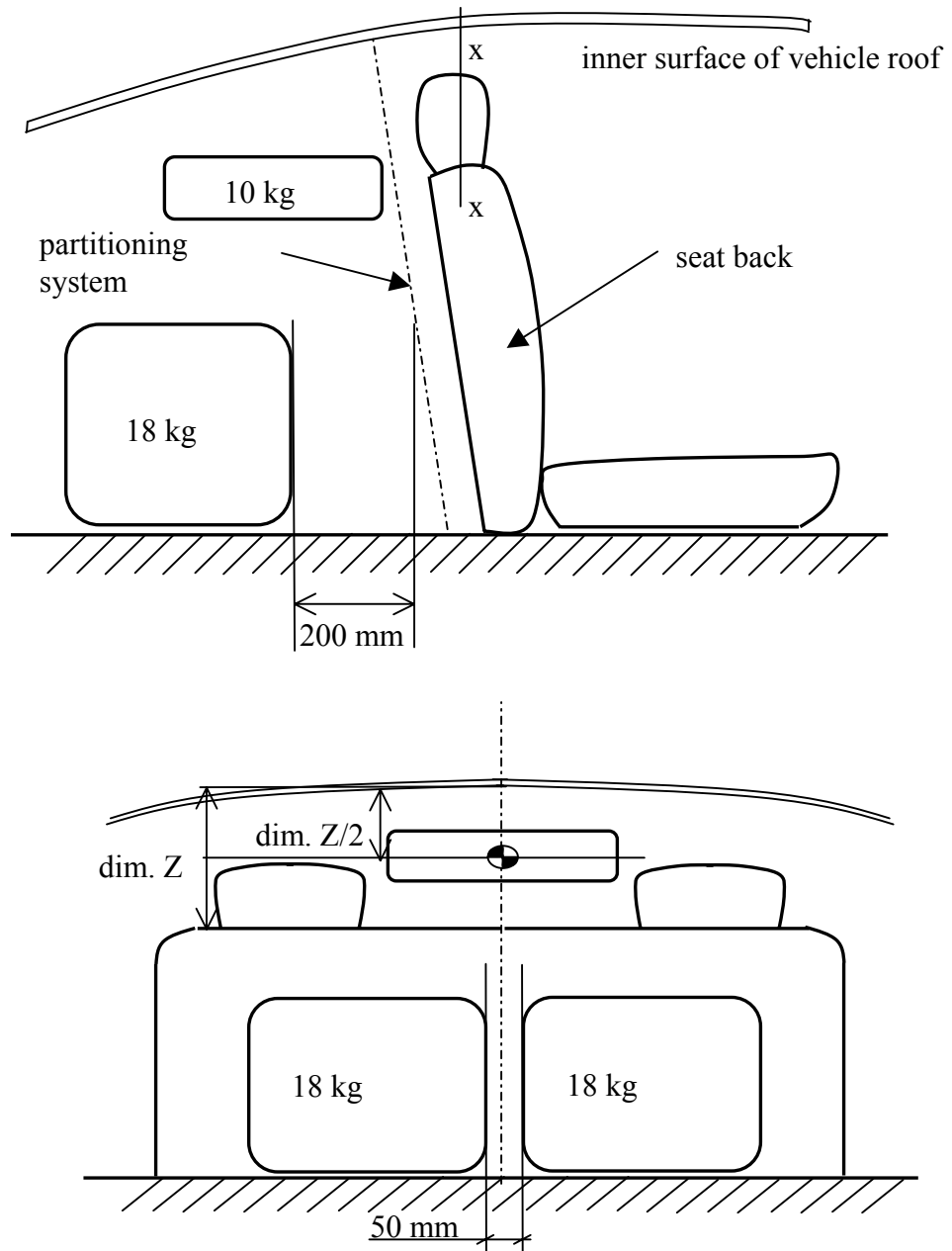

Annex 3 – Appendix 3

POSITION OF THE PLANE OF MAXIMUM PARTITIONING SYSTEM DEFLECTION

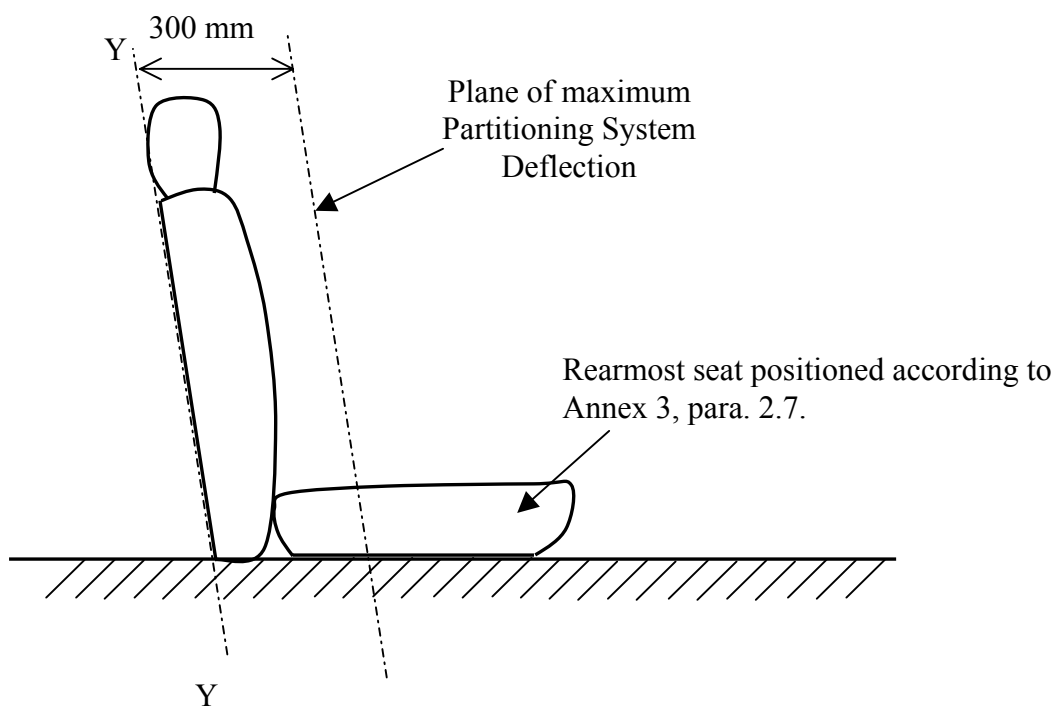

Annex 4

EXAMPLE OF AN APPARATUS TO TEST
THE STRENGTH OF PARTITIONING SYSTEMS

