



Secretariat

Distr.
GENERAL

ST/SG/AC.10/32/Add.2
23 February 2005

ENGLISH
ORIGINAL: ENGLISH AND FRENCH

**COMMITTEE OF EXPERTS ON THE TRANSPORT OF
DANGEROUS GOODS AND ON THE GLOBALLY
HARMONIZED SYSTEM OF CLASSIFICATION
AND LABELLING OF CHEMICALS**

REPORT OF THE COMMITTEE OF EXPERTS
ON ITS SECOND SESSION

(Geneva, 10 December 2004)

Addendum 2

Annex 2

**Amendments to the fourth revised edition of the Recommendations on the Transport
of Dangerous Goods, Manual of Test and Criteria**

This annex contains amendments to the fourth revised edition of the Recommendations on the Transport of Dangerous Goods, Manual of Tests and Criteria (ST/SG/AC.10/11/Rev.4), adopted by the Committee at its second session.

**AMENDMENTS TO THE FOURTH REVISED EDITION OF THE RECOMMENDATIONS ON
THE TRANSPORT OF DANGEROUS GOODS, MANUAL OF TESTS AND CRITERIA
(Refer to ST/SG/AC.10/11/Rev.4)**

SECTION I

Insert the following NOTE under "GENERAL INTRODUCTION":

"NOTE: This general introduction relates only to Parts I to III of the Manual of Tests and Criteria and its Appendices 1 to 6. At its second session (10 December 2004), the Committee of Experts on the Transport of Dangerous Goods and on the Globally Harmonized System of Classification and Labelling of Chemicals decided to add a new Part IV relating to tests methods concerning transport equipment."

PART II

SECTION 20

20.2.1 (b) Amend to read as follows:

"(b) They are oxidizing substances according to the classification procedure for Division 5.1 (see section 34) except that mixtures of oxidizing substances which contain 5.0% or more of combustible organic substances shall be subjected to the classification procedure defined in the NOTE below;"

Add a new NOTE to read as follows:

"NOTE: Mixtures of oxidizing substances meeting the criteria of Division 5.1 which contain 5.0% or more of combustible organic substances, which do not meet the criteria mentioned in (a), (c), (d) or (e) above, shall be subjected to the self-reactive substance classification procedure.

A mixture showing the properties of a self-reactive substance, type B to F, shall be classified as a self-reactive substance of Division 4.1.

A mixture showing the properties of a self-reactive substance, type G, according to the principle of 20.4.2 (g) shall be considered for classification as a substance of Division 5.1 (see section 34)."

PART IV

Add a new Part IV to read as follows:

"PART IV

TEST METHODS CONCERNING TRANSPORT EQUIPMENT

SECTION 40

INTRODUCTION TO PART IV

40.1 Purpose

40.1.1 Part IV of the Test manual presents the United Nations schemes for dynamic and longitudinal impact testing of portable tanks and MEGCs (see section 41 of this Manual and 6.7.2.19.1, 6.7.3.15.1, 6.7.4.14.1 and 6.7.5.12.1 of the Model Regulations).

40.2 Scope

40.2.1 The test methods of this Part should be applied when required by the Model Regulations.

SECTION 41

DYNAMIC LONGITUDINAL IMPACT TEST FOR PORTABLE TANKS AND MULTIPLE-ELEMENT GAS CONTAINERS (MEGCs)

41.1 General

41.1.1 This test method is intended to prove the ability of portable tanks and MEGCs to withstand the effects of a longitudinal impact, as required by 6.7.2.19.1, 6.7.3.15.1, 6.7.4.14.1 and 6.7.5.12.1 of the Model Regulations.

41.1.2 A representative prototype of each design of portable tank and MEGC meeting the definition of "container" under the International Convention for Safe Containers, 1972, as amended (CSC), shall be subjected to and shall satisfy the requirements of the dynamic longitudinal impact test. Testing shall be conducted by facilities approved for this purpose by the competent authority.

41.2 Permitted design variations

The following variations in container design from an already tested prototype are permitted without additional testing:

- (a) A decrease in the initial maximum design temperature, not affecting thickness;
- (b) An increase in the initial minimum design temperature, not affecting thickness;
- (c) A decrease in the maximum gross mass;
- (d) A reduction in capacity not exceeding 10% resulting only from variations in diameter or length;

- (e) A change of location or a modification to nozzles and manholes provided that:
 - (i) an equivalent level of protection is maintained; and
 - (ii) the most unfavourable configuration is used for the purpose of the tank strength calculations;
- (f) An increase in the number of baffles and surge plates;
- (g) An increase in wall thickness provided the thickness stays within the range permitted by the welding procedures specifications;
- (h) A decrease of the maximum allowable working pressure, or maximum working pressure, not affecting thickness;
- (i) An increase in the insulation system effectiveness from using:
 - (i) a greater thickness of the same insulating material; or
 - (ii) the same thickness of a different insulating material having better insulation properties;
- (j) A change to the service equipment provided that the untested service equipment:
 - (i) is located at the same place and meets or exceeds the same performance specification as the existing equipment; and
 - (ii) is approximately of the same size and mass as the existing equipment; and
- (k) The use of a different grade of the same type of material for the construction of the shell or frame, provided that:
 - (i) The results of the design calculations for the different grade, using the most unfavourable specified values of mechanical properties for that grade, meet or exceed the results of the design calculation for the existing grade; and
 - (ii) The alternate grade is permitted by the welding procedures specifications.

41.3 Test apparatus

41.3.1 *Test platform*

The test platform may be any suitable structure capable of sustaining without significant damage a shock of the prescribed severity with the container-under-test mounted securely in place. The test platform shall be:

- (a) configured so as to allow the container-under-test to be mounted as close as possible to the impacting end;
- (b) equipped with four devices, in good condition, for securing the container-under-test in accordance with ISO 1161:1984 (Series 1 Freight containers – Corner fittings – Specification); and
- (c) equipped with a cushioning device to provide a suitable duration of impact.

41.3.2 *Impact creation*

41.3.2.1 The impact shall be created by:

- (a) the test platform striking a stationary mass; or
- (b) the test platform being struck by a moving mass.

41.3.2.2 When the stationary mass consists of two or more railway vehicles connected together, each railway vehicle shall be equipped with cushioning devices. Free play between the vehicles shall be eliminated and the brakes on each of the railway vehicles shall be set.

41.3.3 *Measuring and recording system*

41.3.3.1 Unless otherwise specified, the measuring and recording system shall comply with ISO 6487:2002 (Road vehicles – Measurement techniques in impact tests – Instrumentation).

41.3.3.2 The following equipment shall be available for the test:

- (a) Two accelerometers with a minimum amplitude range of 200 g, a maximum lower frequency limit of 1 Hz and a minimum upper frequency limit of 3000 Hz. Each accelerometer shall be rigidly attached to the container-under-test at the outer end or side face of the two adjacent bottom corner fittings closest to the impact source. The accelerometers shall be aligned so as to measure the acceleration in the longitudinal axis of the container. The preferred method is to attach each accelerometer to a flat mounting plate by means of bolting and to bond the mounting plates to the corner fittings;
- (b) A means of measuring the velocity of the moving test platform or the moving mass at the moment of impact;
- (c) An analogue-to-digital data acquisition system capable of recording the shock disturbance as an acceleration versus time history at a minimum sampling frequency of 1000 Hz. The data acquisition system shall incorporate a low-pass anti-aliasing analogue filter with a corner frequency set to a minimum of 200 Hz and a maximum of 20% of the sampling rate, and a minimum roll off rate of 40 dB/octave; and
- (d) A means of storing the acceleration versus time histories in electronic format so that they can be subsequently retrieved and analysed.

41.3.4 *Procedure*

41.3.4.1 Filling the container-under-test may be undertaken before or after mounting on the test platform, as follows:

- (a) Portable tanks: The tank shall be filled with water or any other non-pressurized substance to approximately 97% of the tank volumetric capacity. The tank shall not be pressurized during the test. If for reasons of overload it is not desirable to fill to 97% of capacity, the tank shall be filled so that the mass of the container-under test(tare and product) is as close as practicable to its maximum rated mass (R);
- (b) MEGCs: Each element shall be filled with an equal quantity of water or any other non-pressurized substance. The MEGC shall be filled so that its mass is as close as practicable to its maximum rated mass (R) but in any event, to no more than 97% of

its volumetric capacity. The MEGC shall not be pressurized during the test. Filling a MEGC is not required when its tare mass is equal to or higher than 90% of R.

41.3.4.2 The mass of the container, as tested, shall be measured and recorded.

41.3.4.3 The container-under-test shall be oriented in a manner that will result in the most severe test. The container shall be mounted on the test platform, as close as possible to the impacting end and secured using all four of its corner fittings so as to restrain its movement in all directions. Any clearance between the corner fittings of the container-under-test and the securing devices at the impacting end of the test platform shall be minimised. In particular, impacting masses shall be free to rebound after impact.

41.3.4.4 An impact shall be created (see 41.3.2) such that for a single impact the as tested Shock Response Spectrum (SRS, see 41.3.5.1) curve at both corner fittings at the impacting end equals or exceeds the minimum SRS curve shown in Figure 1 at all frequencies within the range from 3 Hz to 100 Hz. Repeated impacts may be required to achieve this result but the test results for each impact shall be considered individually;

41.3.4.5 Following an impact described in 41.3.4.4, the container-under-test shall be examined and the results recorded. To satisfy the test, the container shall show no leakage, permanent deformation or damage that would render it unsuitable for use, and shall be in conformity with the dimensional requirements regarding handling, securing and transfer from one means of transport to another.

41.3.5 *Processing and analysis of data*

41.3.5.1 *Data reduction system*

- (a) The acceleration versus time history data from each channel shall be reduced to the shock response spectrum, ensuring that the spectra are presented in the form of equivalent static acceleration plotted as a function of frequency. The maximum absolute value acceleration peak shall be recorded for each of the specified frequency break points. The data reduction shall follow the following criteria:
 - (i) If required, the corrected impact acceleration versus time history data shall be scaled using the procedure outlined in section 41.3.5.2;
 - (ii) The acceleration versus time history data shall comprise the period commencing 0.05 seconds prior to the start of the impact event and the 2.0 seconds thereafter;
 - (iii) The analysis shall span the frequency range of 2 to 100 Hz and calculation of the shock response curve points shall be performed at a minimum of 30 frequency break points per octave. Each break point in the range shall constitute a natural frequency; and
 - (iv) A damping ratio of 5% shall be used in the analysis;
- (b) Calculation of the test shock response curve points shall be made as described below. For each frequency break point:
 - (i) A matrix of relative displacement values shall be calculated using all data points from the shock input acceleration versus time history using the following equation:

$$\mathbf{x}_i = -\frac{z\Delta t}{\omega_d} \sum_{k=0}^i \ddot{\mathbf{x}}_k e^{-z\omega_n \Delta t (i-k)} \sin[\omega_d \Delta t (i-k)]$$

where:

Δt = time interval between acceleration values;

ω_n = undamped natural frequency (in radians);

ω_d = damped natural frequency = $\omega_n \sqrt{1-z^2}$;

$\ddot{\mathbf{x}}_k$ = k_{th} value of acceleration input data;

ζ = damping ratio;

i = integer number, varies from 1 to the number of input acceleration data points;

k = parameter used in summation which varies from 0 to the current value of i .

- (ii) A matrix of relative accelerations shall be calculated using the displacement values obtained in step i in the following equation:

$$\ddot{\mathbf{x}}_i = 2z\omega_n \Delta t \sum_{k=0}^i \ddot{\mathbf{x}}_k e^{-z\omega_n \Delta t (i-k)} \cos[\omega_d \Delta t (i-k)] + \omega_n^2 (2z^2 - 1) \mathbf{x}_i$$

- (iii) The maximum absolute acceleration value from the matrix generated in step ii for the frequency break point under consideration shall be retained. This value becomes the SRS curve point for this particular frequency break point. Step i shall be repeated for each natural frequency until all natural frequency break points have been evaluated.

- (iv) The test shock response spectrum curve shall be generated.

41.3.5.2 Method for scaling measured acceleration versus time history values to compensate for under or over mass containers

Where the sum of the as-tested payload mass plus tare mass of the container-under-test is not the maximum rated mass of the container-under-test, a scaling factor shall be applied to the measured acceleration versus time histories for the container-under-test as follows:

The corrected acceleration-time values, $Acc(t)_{(corrected)}$, shall be calculated from the measured acceleration versus time values using following formula:

$$Acc(t)_{(corrected)} = Acc(t)_{(measured)} \times \frac{1}{\sqrt{1 + \frac{\Delta M}{M_1 + M_2}}}$$

Where:

$Acc(t)_{(measured)}$ = actual measured-time value;

M_1 = mass of the test platform, without the container-under-test;

M_2 = actual test mass (including tare) of the container-under-test;

R = the maximum rated mass (including tare) of the container-under-test;

ΔM = $R - M_2$;

The test SRS values shall be generated from the $Acc(t)$ _(corrected) values.

41.3.6 *Defective instrumentation*

If the acquired signal from one accelerometer is faulty the test may be validated by the SRS from the functional accelerometer after three consecutive impacts provided that the SRS from each of the three impacts meets or exceeds the minimum SRS curve.

41.3.7 *Alternate test severity validation method for portable tanks with frame length of 20 feet*

41.3.7.1 If the design of a tank container-under-test is significantly different from other containers successfully subjected to this test and the SRS curves obtained have correct features but remain below the minimum SRS curve, the test severity may be considered acceptable if three successive impacts are performed as follows:

- (a) First impact at a speed higher than 90% of the critical speed referred to in 41.3.7.2; and
- (b) Second and third impact at a speed higher than 95% of the critical speed referred to in 41.3.7.2.

41.3.7.2 The alternate validation method described in 41.3.7.1, shall be used only if the platform's "critical speed" had been determined beforehand. The critical speed is the speed where the platform's cushioning devices reach their maximum travel and energy absorption capacity beyond which the minimum SRS curve is normally obtained or exceeded. The critical speed shall have been determined from a minimum of five documented tests on five different tank containers. Each such test shall have been performed using the same equipment, measuring system and procedure.

41.3.8 *Recording of data*

At least the following data shall be recorded in the application of this procedure:

- (a) Date, time, ambient temperature, and location of test;
- (b) Container tare mass, maximum rated mass, and as-tested payload mass;
- (c) Container manufacturer, type, registration number if applicable, certified design codes and approvals if applicable;
- (d) Test platform mass;
- (e) Impact velocity;
- (f) Direction of impact with respect to container; and
- (g) For each impact, an acceleration versus time history for each instrumented corner fitting.

Figure 41.1: Minimum SRS Curve

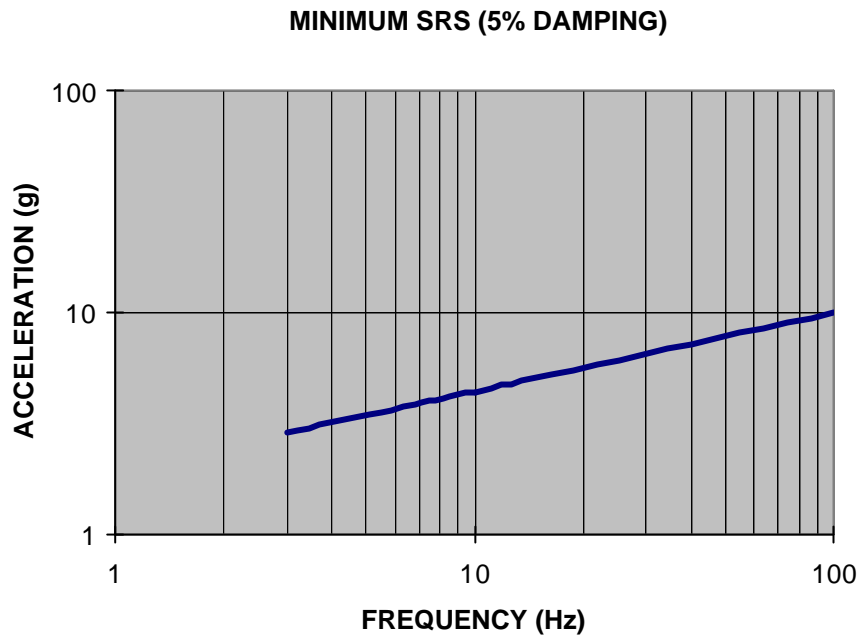

Equation for generating the above Minimum SRS Curve: $ACCEL = 1.95 \text{ } FREQ^{0.355}$

Table 41.1. Tabular representation of some data points for the minimum SRS curve above.

FREQUENCY (Hz)	ACCELERATION (g)
3	2.88
10	4.42
100	10.0

APPENDICES

APPENDIX 5

Amend to read as follows:

"APPENDIX 5

EXAMPLE OF A TEST METHOD FOR VENT SIZING

1. Introduction

This example of a method for vent sizing is used to determine the required emergency vent capacity to be fitted to a specific IBC or tank for a particular organic peroxide Type F, or self-reactive substance Type F, or formulations thereof. The method is based on experimental data which indicates that, for organic peroxide or self-reactive substance formulations, the ratio of the minimum emergency vent area to the capacity of the IBC or tank is constant and can be determined using a reduced scale tank with a 10 litre capacity. In the tests, the reduced scale tank is heated at rates equivalent to that given by complete fire engulfment or, in the case of insulated IBC or tanks, the heat transfer through the insulation with the assumption that 1% of the insulation is missing (see 4.2.1.13.8 and 4.2.1.13.9 of the Model Regulations). Others methods may be used provided that they adequately size the emergency relief

device(s) on an IBC or a tank to vent all the material evolved during self-accelerating decomposition or a period of not less than one hour of complete fire-engulfment.

Warning: The method does not take into account the possibility of initiation of deflagration. If this is a possibility, particularly if initiation in the vapour phase can propagate to the liquid phase, then tests should be performed which take this into account.

2. Apparatus and materials

The reduced scale tank consists of a stainless steel test vessel with a gross volume of 10 l. The top of the tank is provided with either a 1 mm opening which simulates the pressure relief valve (PRV) of the IBC or tank or a real PRV of a diameter which is scaled using the vent area to vessel volume ratio. A second opening simulates the emergency vent opening and is closed by a bursting disk. The diameter of this vent opening can be varied by using orifice plates with different apertures. The bursting pressure of the disk fixed to the 10 l vessel should be equal to the maximum rupture pressure of the bursting disks to be fitted to the IBC or tank. This pressure should be lower than the test pressure of the tank involved. Usually, the bursting pressure is set at a level that can cope with the pressures encountered during normal transport conditions such as hydrostatic pressure from the liquid due to turn over of the tank, slopping of the contents, etc. The 10 l vessel should be provided with a bursting disk with a set pressure in the range of the disk(s) fitted on the tank or IBC as to be used in transport. For safety, it is recommended to provide the test vessel with an extra bursting disk (bursting pressure approximately 80% of the design pressure of the 10 l test vessel) with a large opening for additional emergency venting of the test vessel in the event that the chosen orifice diameter is too small.

The outer surface of the test vessel, below the liquid level, is provided with an electrical heating coil or cartridge heaters connected to a power supply. Vessel contents should be heated at a constant rate independent of the heat being generated by the organic peroxide or self-reactive substance. The resistance of the heating coil should be such that, with the power available, the calculated heating rate (see section 3) can be achieved. The whole vessel is insulated with rock wool, cellular glass or ceramic fibre.

The temperature inside the tank is measured by means of three thermocouples, two located in the liquid phase (near the top and bottom) and one in the gas phase. Two thermocouples are used in the liquid phase to check the homogeneity of the heating. The pressure is recorded by a pressure transducer(s) capable of recording slow and fast (at least 1000 points/sec.) changes of pressure. Examples of test vessels are illustrated in Figure A5.1. Additional information may be obtained if the tank is mounted in a tray designed to collect any solids or liquids ejected.

The tests should be performed at a test site with suitable safety distances. Alternatively, the test can be performed in a bunker provided with sufficient ventilation and vent openings to prevent pressure build-up in it. Explosion-proof electrical equipment should be used in such a bunker to minimise the risk of ignition. ***However, the tests should be performed on the assumption that the decomposition products will ignite.***

3. Calculation of the heating rate to be used in the test

If an IBC or tank is non-insulated, a heat load of the shell as given in 4.2.1.13.8 of the Model Regulations is required. For an insulated IBC or tank, the Model Regulations require that the heat load to the shell be equivalent to the heat transfer through the insulation plus the heat load to the shell on the assumption that 1% of the insulation is missing.

The following information on the IBC or tank and organic peroxide or self-reactive substance is needed for the heating rate calculation:

F_r	= fraction of tank directly heated (1 if non-insulated, 0.01 if insulated)	[-]
M_t	= total mass of organic peroxide or self-reactive substance and diluent	[kg]
K	= heat conductivity of the insulation layer	[W.m ⁻¹ .K ⁻¹]
L	= thickness of insulation layer	[m]
U	= K/L = heat transfer coefficient	[W.m ⁻² .K ⁻¹]
A	= wetted area of IBC or tank	[m ²]
C_p	= specific heat of the organic peroxide or self-reactive substance formulation	[J.kg ⁻¹ .K ⁻¹]
T_{po}	= temperature of organic peroxide or self-reactive substance formulation at relieving conditions	[K]
q_i	= indirectly exposed heat	[W]
q_d	= directly exposed heat	[W]
F	= insulation factor	[-]

Heat input, q_i (W), via indirectly exposed surface (insulated part) is calculated by equations (1) and (2):

$$q_i = 70961 \times F \times [(1 - F_r) \times A]^{0.82} \quad (1)$$

where: F = insulation factor;
 $F = 1$ for non-insulated shells, or

$$F = 2 \times \frac{U(923 - T_{po})}{47032} \quad \text{for insulated shells} \quad (2)$$

In the calculation of F a multiplication factor of 2 is introduced to take into account a 50% loss in insulation efficiency in an incident.

Heat input, q_d (W), via the directly exposed surface (non-insulated part) is calculated by equation (3):

$$q_d = 70961 \times F \times [F_r \times A]^{0.82} \quad (3)$$

where: F = insulation factor = 1 (non-insulated)

The overall heating rate, dT/dt (K/min), due to fire engulfment is calculated by equation (4):

$$\frac{dT}{dt} = \frac{(q_i + q_d)}{M_t C_p} \times 60 \quad (4)$$

Example 1: insulated tank

For a typical 20 m³ insulated tank:

F_r	= fraction of tank directly heated	= 0.01
M_t	= total mass of organic peroxide or self-reactive substance and diluent	= 16 268 kg
K	= heat conductivity of the insulation layer	= 0.031 W.m ⁻¹ .K ⁻¹
L	= thickness of the insulation layer	= 0.075 m
U	= heat transfer coefficient	= 0.4 W.m ⁻² .K ⁻¹
A	= wetted area of tank	= 40 m ²
C_p	= specific heat of the organic peroxide form	= 2 000 J.kg ⁻¹ .K ⁻¹
T_{po}	= temperature of peroxide at relieving conditions	= 100 °C

and

$$q_i = 70961 \times 2 \times \frac{0.4 \times (923 - 373)}{47032} \times [(1 - 0.01) \times 40]^{0.82} = 13558 \text{ W}$$

$$q_d = 70961 \times 1 \times [0.01 \times 40]^{0.82} = 33474 \text{ W}$$

$$\frac{dT}{dt} = \frac{(13558 + 33474)}{16268 \times 2000} \times 60 = 0.086 \text{ K} \cdot \text{min}^{-1}$$

Example 2: non-insulated IBC

For a typical 1.2 m³ non-insulated stainless steel IBC (only direct heat input, q_d):

F_r	=	fraction of tank directly heated	=	1
M_t	=	total mass of organic peroxide and diluent	=	1 012 kg
A	=	wetted area of IBC	=	5.04 m ²
C_p	=	specific heat of the organic peroxide form	=	2 190 J.kg ⁻¹ .K ⁻¹

and

$$q_d = 70961 \times 1 \times [1 \times 5.04]^{0.82} = 267308 \text{ W}$$

$$q_d = 0$$

$$\frac{dT}{dt} = \frac{(0 + 267308)}{1012 \times 2190} \times 60 = 7.2 \text{ K} \cdot \text{min}^{-1}$$

4. Procedure

Fill the test vessel shell with the amount of organic peroxide or self-reactive substance required to give the same degree of fill (by volume of the shell) as to be used in the tank (maximum degree of fill 90 %, by volume) and then install the required orifice plate¹ and bursting disk. For example, it is common practice to fit four 250 mm diameter bursting disks to a 20 ton tank. This corresponds to a test vessel orifice diameter of about 11 mm.

The vessel is heated at the desired rate by applying power to the heating coil. A higher than calculated heating rate may be applied initially until a temperature 5 °C above the self-accelerating decomposition temperature (for a 50 kg package) of the organic peroxide or self-reactive substance is reached. The calculated heating rate should be applied once this temperature is reached. The temperature and pressure in the test vessel are recorded during the entire experiment. After rupture of the bursting disk, the heating should be continued for approximately 30 minutes more to be sure that all dangerous effects are measured. **Keep distance during the execution of the test and afterwards the vessel should not be approached until the contents have cooled.**

The diameter of the orifice should be varied (if necessary) until a suitable opening is determined at which the maximum recorded pressure does not exceed the pressure as specified in Section 5, Test

¹ It is recommended that either small-scale vent experiments (100 - 200 ml scale) or experiments using a very strong vessel (>100 bar) be performed prior to the performance of the 10 l vent test in order to obtain information on the maximum pressure effect from the test substance and on the required orifice diameter to be used in the first 10 l scale vent test.

criteria and method of assessing the results. The step size used should be related to the options available in practice for the tank, i.e. larger vent sizes or more vents. If necessary the concentration of the organic peroxide or self-reactive substances can be lowered. The test should be performed in duplicate at the level at which the total vent area has sufficient capacity.

5. Test criteria and method of assessing the results

The minimum or suitable (if it is acceptable to use a vent size larger than the minimum vent size) IBC or tank vent area, A_{IBC} or A_{tank} (m^2), can be calculated using the minimum or suitable orifice vent area as tested in the 10 litre test at which the maximum pressure during venting is:

- for tanks not more than test pressure of the tank (according to 4.2.1.13.4 tank shall be designed for a test pressure of at least 0.4 MPa),
- for IBC not more than 200 kPa gauge pressure, as tested according 6.5.4.8.4, or higher under an approval granted by the competent authority,

and the volumes of the test vessel and IBC or tank.

The minimum total IBC or tank vent area is given by:

$$\text{For IBCs:} \quad A_{IBC} = V_{IBC} \times \left(\frac{A_{\text{test vessel}}}{V_{\text{test vessel}}} \right)$$

$$\text{For tanks:} \quad A_{\text{tank}} = V_{\text{tank}} \times \left(\frac{A_{\text{test vessel}}}{V_{\text{test vessel}}} \right)$$

where:

$A_{\text{test vessel}}$	=	Area of venting of 10 litre test vessel	=	$[m^2]$
A_{IBC}	=	Area of venting of IBC	=	$[m^2]$
A_{tank}	=	Area of venting of tank	=	$[m^2]$
$V_{\text{test vessel}}$	=	Volume of test vessel	=	$[m^3]$
V_{IBC}	=	Volume of IBC	=	$[m^3]$
V_{tank}	=	Volume of tank	=	$[m^3]$

Example:

For a typical organic peroxide in a $20 m^3$ insulated tank:

$A_{\text{test vessel}}$	=	Minimum suitable orifice area found in test	=	$9.5 \times 10^{-5} m^2$
V_{tank}	=	Volume of tank	=	$20 m^3$
$V_{\text{test vessel}}$	=	Volume of test vessel	=	$0.01 m^3$

$$A_{\text{tank}} = 20 \times \left(\frac{9.5 \times 10^{-5}}{0.01} \right) = 0.19 m^2$$

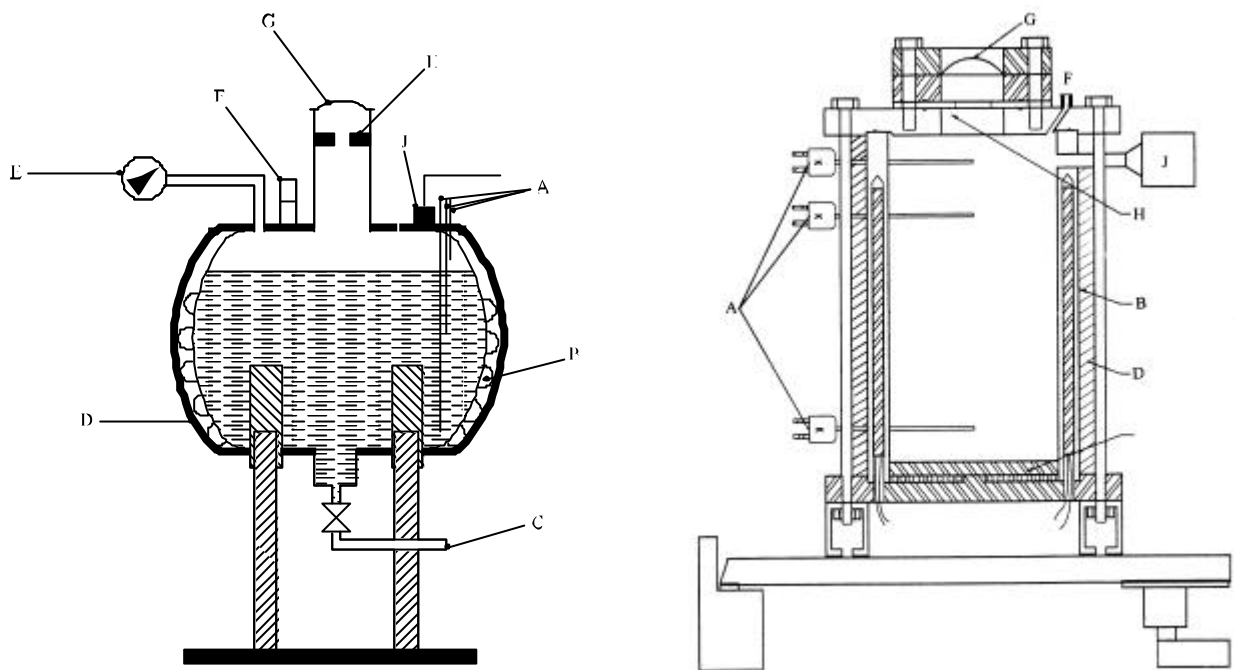

-
- (A) Thermocouples (two in liquid on one in vapour space)
 - (B) Heating coil/heating cartridge
 - (C) Drain line, optional
 - (D) Insulation
 - (E) Manometer, optional
 - (F) Pressure relief valve, optional
 - (G) Bursting disk
 - (H) Orifice plate
 - (J) Pressure transducer or pressure relief valve & transducer on tee
-

Figure A5.1: 10 LITRE VESSELS FOR VENTING TESTS"