

UN/ECE/WP29/GRSP Pedestrian Safety gtr Informal Group 2nd Interim Report

1. Introduction

- At the 33rd GRSP (2-6 June 2003) meeting, the informal group on pedestrian safety presented its first preliminary report as informal document 2. The document was adopted by GRSP and by WP29.
- The first preliminary report included amongst other:
 - Accident analysis looking at:
 - ◇ Overall pedestrian fatalities / injuries and their evolution over time
 - ◇ Distribution of injuries
 - ◇ Crash Speeds
 - The conclusions from this analysis were:
 - ◇ The majority of fatalities (numbers) and serious injuries occurred on:
 - Child head vs. top surface of bonnet/ wing.
 - Adult head vs. top surface of bonnet/wing + windscreen area and A-pillars,
 - Adult leg vs. front bumper of vehicles,
 - ◇ A crash speed (between a car and a pedestrian) of 40 km/h can cover more than 75% of total injuries including fatalities. Injuries caused by higher speed crashes will also be influenced positively by a reduction in injury severity.
 - The group also asked advice on the approach it took for the scope and is still awaiting clear directions from WP29.
- Based on this first preliminary report and on request of GRSP, the informal group continued its work and started with the development of a gtr.

2. Draft gtr proposal: working paper.

The working paper for the draft gtr can be found attached. The working paper is a mix of decided items and items that are still under study. An action plan is in place (see item 3) to provide answers for all the questions that are left unanswered at this stage.

The preamble will be included in the first official draft gtr proposal to GRSP in December 2004. The preamble will include cost effectiveness/benefits conclusions, conflicts with other existing requirements, other measures that can be potentially reduce pedestrian injuries, etc.

○ Legform test to bumper

Either the lower or the upper legform test are required to be performed:

● Lower legform to bumper

- Impact zone: On the bumper
- Impact speed of the impactor: 40 km/h
- Test tool:

- The existing lower legform impactor used in the EU

Or

- The FlexPLI legform developed in Japan.

The group is undertaking further studies to enable a decision on the selection of the impactor.

○ Criteria:

- dynamic knee bending angle < [21]°, maximum dynamic knee shearing displacement < [6]mm; acceleration < [200]g for the EU impactor

Or

- dynamic knee bending angle < [20]°, [maximum dynamic knee shearing displacement <

[6]mm, acceleration < [200]g], tibia bending moment < [350] Nm for the FlexPLI impactor

- [Upper legform to bumper (at the manufacturer request if the lower bumper height at the test position > 500 mm)
 - Impact zone: On the bumper
 - Impact speed of the impactor: 40 km/h
 - Test tool:
 - The existing lower legform impactor used in the EU
 - Criteria:
 - sum of impact forces < [7,5] kN; bending moment < [510] Nm]

- Child Head protection requirements
 - Impact zone
 - 1000 < WAD (Wrap Around Distance) < 1700
 - Includes A-pillar/windscreen area
 - Test tool
 - 165 mm diameter
 - 3,5 kg mass
 - Impact speed of impactor: [32] km/h
 - Impact angles

Depends on vehicle shape (bonnet angle (BA), bonnet leading edge height (BLEH)):

Child	BLEH < 835 mm (Sedan)	BLEH > 835 mm (SUV)	BA > 30° (1 box)
Bonnet	65°	60°	25°
Windscreen	40°	40°	25°
 - Criteria
 - HIC < [1000] for the child headform test area.
 - HIC < 1000 for the windscreen test area
 - The group agreed that the area required to meet HIC < 1000 may need revision and some consideration given to allow some exemption zones.

- Adult Head protection requirements
 - Impact zone
 - 1700 < WAD < 2100
 - Includes A-pillar/windscreen area
 - Test tool
 - 165 mm diameter
 - [4,5] kg mass
 - Impact speed of impactor [32] km/h
 - Impact angles

Depends on vehicle shape (bonnet angle (BA), bonnet leading edge height (BLEH)):

Adult	BLEH < 835 mm	BLEH > 835 mm	BA > 30°
Bonnet	65°	90°	50°
Windscreen	40°	40°	50°
 - Criteria
 - HIC < [1000] for the child headform test area.
 - HIC < 1000 for the windscreen test area
 - The group agreed that the area required to meet HIC < 1000 may need revision and some consideration given to allow some exemption zones.

- Adult Upper Leg protection requirements:

The group agreed that inclusion of the upper leg test to the bonnet leading edge needed further review. In particular it must be verified whether this test is actually needed on the basis of accident data, technical feasibility, test procedure repeatability, reproducibility, etc.

3. Action plan

- General time schedule:
 - draft gtr (based on updated PS/69) to May 04 GRSP. To serve as basis for the feasibility / effectiveness / repeatability / reproducibility assessment and resulting in
 - first official draft gtr to Dec 04 GRSP. To serve as basis for comments from all CPs and industry and resulting in

- official draft gtr to May 05 GRSP for final adoption at AC3 in November 05.

- The action plan as agreed during the 6th informal group meeting (see also INF / GR / PS / 83)

For the head test area proposal including the windscreen and A-pillars: Need for more test data (all) Japan to provide J-NCAP data + proposal
Governments to make a recommendation on the selection of the impact points based on their own national / regional approach (recommended impact points versus free selection (worst case) by test house)
Head impact speed: EU and US study reservation: NHTSA to check if more information is available + EU to study results of PS/72.
EU study reservation for specifications of the 3,5 kg headform and for the weight of the adult headform.
Headforms: Accelerometer position accuracy under discussion in J and US. Any info from other source is welcome.
Head impactor skin ageing under study (J)
Head impactors: bring together certification data and check the response uniformity (J, IDIADA).
Include the certification test established by IHRA (PS/49 and PS/50) in the draft gtr.
OICA to give comments on a proposal for an active bonnet test method.
In order to decide which legform to be used we need by Sept 04 : - IHRA to finalise its work asap (corridors, injury risk curves, ...). (Summer 04) - info on repeatability and reproducibility of EU legform (EEVC) / FlexPLI (J) - biofidelity information of FlexPLI (J) / EU impactor (EEVC) - comparison result after test on same car of FlexPLI versus EU impactor (J to provide info on 2 cars) - information on general availability of FlexPLI (J) - information on sensitivity, durability, ... - information on the certification procedures and specifications for each impactor (J, EEVC)
Results of ACEA study on feasibility (EU Phase 2) will be available next meeting. JAMA to check if J mfr can provide feasibility test data. EU feasibility study result will be available next meeting. Korea will check if KAMA has information to share.

4. Attachment

* Working paper for the draft gtr

* All documents used by the informal group can be found on the UN/ECE/WP29/GRSP website. For reference the complete list of working documents is attached:

Number	Title
INF GR/PS/1*	Agenda 1st meeting
INF GR/PS/2	Terms of reference
INF GR/PS/3	IHRA accident study presentation
INF GR/PS/4*	JMLIT proposed legislation
INF GR/PS/5	IHRA feasibility study
INF GR/PS/6	J information on possible scope
INF GR/PS/7	Attendance list 1st meeting
INF GR/PS/8*	Draft Meeting Minutes 1st meeting
INF GR/PS/9*	Report to GRSP 32 inf doc
INF GR/PS/10	Draft action plan
INF GR/PS/11	Agenda 2nd meeting
INF GR/PS/12	GIDAS accident data
INF GR/PS/13	GIDAS accident data graphs
INF GR/PS/14	Italian accident data
INF GR/PS/15	UN accident data
INF GR/PS/16	Spanish accident data
INF GR/PS/17	ACEA accident data
INF GR/PS/18	Draft Meeting Minutes 2nd meeting
INF GR/PS/19	Agenda 3rd meeting
INF GR/PS/20	Canadian accident data
INF GR/PS/21	Netherlands accident data
INF GR/PS/22	Scope overview
INF GR/PS/23	Draft content table preliminary report

INF GR/PS/24	Attendance list 3rd meeting
INF GR/PS/25	GIDAS presentation
INF GR/PS/26	Leg injuries ITARDA
INF GR/PS/27*	Draft Meeting Minutes 3rd meeting
INF GR/PS/28	Technical feasibility general
INF GR/PS/29	Infrastructure effectiveness
INF GR/PS/30	Pelvis / Femur fracture
INF GR/PS/31	IHRA/PS-WG Pedestrian accident data
INF GR/PS/32	ESV summary paper on IHRA/PS-WG report
INF GR/PS/33	Introduction of the regulation of pedestrian head protection in Japan; Nishimoto, Toshiyuki
INF GR/PS/34	Proposal for a directive of the European Parliament and the Council relating to the protection of pedestrians and other vulnerable road users in the event of a collision with a motor vehicle and amending Directive 70/156/EEC; Commission of the European Communities, Brussels, February 2003
INF GR/PS/35	List of conflicts with existing legislation / requirements
INF GR/PS/36	Draft preliminary report
INF GR/PS/37	Agenda 4th meeting
INF GR/PS/38	Technical prescriptions concerning test provisions for pedestrian safety
INF GR/PS/39*	Vehicle safety standards report 1
INF GR/PS/40	US Cumulative 2002 Fleet GVMR
INF GR/PS/41	Swedish accident data
INF GR/PS/42	TRANS/WP.29/GRSG/2003/10 proposal for common definitions
INF GR/PS/43	Category 1-1 GVM
INF GR/PS/44	Light duty truck
INF GR/PS/45	EURO-NCAP results and what they mean in relation to EU Phase 1
INF GR/PS/46	JAMA / JARI child and adult head impactors
INF GR/PS/47*	Preliminary report to GRSP 33
INF GR/PS/48*	Draft meeting minutes 4th meeting
INF GR/PS/49	IHRA child head test method
INF GR/PS/50	IHRA adult head test method
INF GR/PS/51	Attendance list 4th meeting
INF GR/PS/52	Provisional agenda for the 5th meeting
INF GR/PS/53	Draft gtr format
INF GR/PS/54	gtr proposal to WP29
INF GR/PS/55	Draft gtr
INF GR/PS/56*	Comparison table
INF GR/PS/57	Proposed schedule of the group
INF GR/PS/58	Presentation on veh shape, bound line, ...
INF GR/PS/59	A-pillar IHRA OICA presentation
INF GR/PS/60	ISO/TC22/SC10/WG2 N613
INF GR/PS/61	IHRA PS 237
INF GR/PS/62	Action plan from 5 meeting
INF GR/PS/63	Attendance list 5th meeting
INF GR/PS/64*	Draft meeting minutes 5th meeting
INF GR/PS/65*	Provisional agenda for the 6th meeting
INF GR/PS/66	AUS-NCAP pedestrian data
INF GR/PS/67	Test-method - active hood / bonnet systems
INF GR/PS/68	Target population head injuries - US
INF GR/PS/69	Working paper draft gtr
INF GR/PS/70	Korean information
INF GR/PS/71	Head test area windscreen + A-pillar
INF GR/PS/72	Head test data on windscreen
INF GR/PS/73	Head impact angle / speed re-assessment based on vehicle geometry
INF GR/PS/74	IHRA/PS/270 headform impactor specification

INF GR/PS/75	Powerpoint explanation of PS/67
INF GR/PS/76	IHRA legform discussions
INF GR/PS/77	Corridors proposed by UVA (lower legform)
INF GR/PS/78	Bio rating method: Maltese
INF GR/PS/79	IHRA antropometric proposal
INF GR/PS/80	IHRA/PS/278
INF GR/PS/81	Schedule for legform impactor for gtr
INF GR/PS/82	Injury threshold for ped legform test
INF GR/PS/83	Decided items and action items of the 6th meeting
INF GR/PS/84	Draft meeting minutes of the 6th meeting
INF GR/PS/85	Attendance list of the 6th meeting
INF GR/PS/86	Draft gtr EU working document
INF GR/PS/87	IHRA PS 273 Development of FlexPLI2003
INF GR/PS/88	Second interim report to GRSP 35

PEDESTRIAN PROTECTION.

This document is a working document circulated for discussion and comments. It is only submitted with the intention to facilitate discussion by the GRSP Informal Group.

Wording added in blue are comments from OICA

Wording added in red are comments from EU

Wording added in green are comments from Japan

Note: Square brackets '[']' are used in this document to indicate items or sections which require further discussion or clarification which may include changes of values or complete revision of the contents.

Note: This document is distributed to the Experts on Passive Safety Provisions only.

GLOBAL TECHNICAL REGULATION NO. Y

on

UNIFORM PROVISIONS CONCERNING THE APPROVAL OF VEHICLES WITH REGARD TO
THEIR CONSTRUCTION IN ORDER TO IMPROVE THE PROTECTION AND MITIGATE THE
SEVERITY OF INJURIES TO PEDESTRIANS AND OTHER VULNERABLE ROAD USERS IN
THE EVENT OF A COLLISION

Contents:

A. Technical Rationale and Justification	3
B. Text of Regulation	4
1. Purpose and Scope.	4
2. Application.	4
3. Definitions	6
4. General Requirements.	20
5. Performance Requirements.	20
6. Test Conditions.	21
7. Test Procedures.	31
Annexes (Certification procedure)	??

A. Introduction.

[Preamble, Technical rationale and justification for measures to be added].

B. Text of the Regulation**1. Purpose and Scope.**

- 1.1 The purpose of this regulation is to bring about an improvement in the construction of the fronts of vehicles and, in particular, those areas which have been most frequently identified as causing injury when in collision with a pedestrian or other vulnerable road user. The tests required are limited to those elements of the child and adult body most frequently identified as sustaining injury, i.e. the adult head and leg and the child head. To achieve the required improvements in construction of vehicles, the tests are based on sub-system component impactors representing those body regions and impacted at speeds representative of that below which the majority of injuries occur.
- 1.2 The vehicles to be tested under the regulation are representative of the majority of vehicles in circulation in the urban environment, where there is a greater potential for collision with pedestrians and other vulnerable road users, and include passenger cars, vans and light trucks.

2. Application.

- 2.1 This global technical regulation requires specified tests to be completed for the purpose of qualifying vehicles, including passenger cars, vans and light trucks, with respect to the safety of pedestrians and other vulnerable road users.
- 2.2 This global technical regulation applies to those categories of vehicles as detailed in Table 1 below. All contracting parties agreeing to this global technical regulation will indicate, in the table, the vehicle categories and test requirements to be applied in their region.
- The grey coloured cells of Table 1 indicate for which vehicle category the respective tests are validated. It is depending on the contracting parties and their responsibility to select the application of the global technical regulation taking into account the need to validate the test procedure and the requirements for the selected vehicle categories based on the results of studies conducted among others in the framework of EEVC and IHRA.
- OICA comment: It has to be clearly indicated for which the respective test is validated and that it is rather problematic to conduct e.g. headform tests to bus shaped small trucks of category 2 less than 2.5 tons GVW when this vehicle is not derived from a category 1-1 vehicle. The "derived from category 1-1" has to be reinserted in column (c) and (d) of Table 1. The upper legform to BLE test should not be mentioned in Table 1 because it is not seen as a priority within in the GTR Informal Group.*
- EU Comment: All of this blue text would not be required in any legal document. The clause refers directly to the Table and the Table will contain all the results of decisions made by the contracting parties.
- 2.3 Regular reviews will be instituted to ensure the eventual application of this global technical regulation to all vehicles in a reduced set of suitable vehicle categories, on the basis of technical and economic feasibility, for all contracting parties.
- 2.4 Regular reviews will be instituted to ensure that the specifications of the test requirements will be harmonised into a single set of requirements accepted by all contracting parties.
- 2.5 At the time of acceptance of the regulation by any party contracting to the regulation, that contracting party will be required to accept the alternatives available at that time.
- 2.6 Those tests accepted by any contracting party may be phased in with respect to the date of acceptance of the GTR by that contracting party. The details of the phasing in periods shall be stated and appended to the regulation

Vehicle Categories						
	(a)	(b)	(c)	(d)	(e)	(f)
Procedure Application	Category 1-1 Vehicle Mass GVM < 2500 kg	Category 1-1 Vehicle Mass GVM > 2500 kg	Category 2 (derived from 1-1) Vehicle Mass GVM < 2500 kg	Category 2 (derived from 1-1) Vehicle Mass GVM > 2500 kg	Category 2 Vehicle Mass < 3500 kg	...
Legform to Bumper child headform test	Region x Region y Region z	Region y
Upper Legform to Bumper adult headform test	Region x Region y	Region z
Upper Legform to BLE Legform to bumper	Region x	Region x	Region z	...
Child Headform Upper legform to bumper
.....

Table 1: Agreed Scope and Application for the purposes of this Regulation.

[Notes: Examples of Region: Region x covers all European Member states, Region y covers Japan, Region z covers the US, etc. for other contracting parties.

The column of tests will continue for each potential agreed alternative test.

The use of this approach still requires some guidance and approval from WP.29.]

[EU Comment: The question of a 'derived from' category is not presently accepted for the purposes of this gr. This Table has ever only been used to provide example and the contents in any final version have yet to be agreed.](#)

3. Definitions.

[Note: The definitions contained in this section are not yet necessarily complete and may be altered or added to when the full document is further reviewed.]

When performing measurements on a vehicle as described in this Part, the vehicle should be positioned in its normal ride attitude as described in paragraph 3.20. If the vehicle is fitted with a badge, mascot or other structure which would bend back or retract under a low applied load, then such a load shall be applied before and/or while these measurements are taken. Any vehicle component which could change shape or position, such as ‘pop-up’ headlights, other than suspension components or active devices to protect pedestrians, shall be set to a shape or position, [based on a determination by each contracting party or regional economic integration organisation,] considered to be the most appropriate for use on public roads while taking these measurements.

For the purposes of this regulation:

- 3.1 “**Adult Headform Test Area**” means the outer surfaces of the front structure, ~~the windscreen, the A-pillars and the windscreen header~~ as defined in paragraph 3.14. It is bounded, in the front, by a wrap around distance of 1700mm, as defined in paragraph 3.32, and, at the rear, by the rear reference line for adult headform, as defined in paragraph 3.21, and, at each side, by the side reference line as defined in paragraph 3.24.

EU Comment: Could read as follows:

“**Adult Headform Test Area**” means certain outer surfaces of the front structure, as defined in paragraph 3.14.

The area is bounded, in the front, by a wrap around distance”

- 3.2 “**A-pillar**” means the foremost and outermost roof support extending from the chassis to the roof of the vehicle.

- 3.3 “**Bonnet angle**” means ...

“**The bonnet effective angle**” shall be the angle, against the horizontal plane, of a straight line connecting the intersecting point of the BLE reference line and the vertical plane containing a vehicle longitudinal axis and the intersecting point of the bonnet panel rear edge (if the vehicle has no bonnet panel, the front panel rear edge) and the same vertical plane. The angle designated by the manufacturer may be deemed as the bonnet effective angle, if it is within $\pm 2^\circ$ of the actual measurement.

OICA comment: copy of chapter 3.3.2.2 of the J-MLIT draft (03.03.04) and deletion of “effective”.

[Note: This definition will be taken from HRA J-MLIT definitions.]

- 3.4 “**Bonnet leading edge (BLE)**” means the front upper outer structure including the bonnet and wings, the upper and side members of the headlight surrounds and any other attachments. The reference line identifying the position of the bonnet leading edge is defined by its height above the ground reference plane and by the horizontal distance separating it from the bumper (bumper lead), as determined in accordance with paragraph 3.10.

- 3.5 “**Bonnet leading edge height (BLEH)**” means the vertical distance between the ground reference plane and the bonnet leading edge reference line, defined in point 3.6, with the vehicle positioned in its normal ride attitude.

- 3.6 “**Bonnet leading edge reference line**” means the geometric trace of the points of contact between a straight edge 1000 mm long and the front surface of the bonnet, when the straight edge, held parallel to the vertical longitudinal plane of the car and inclined rearwards by 50° and with the lower end 600 mm above the ground, is traversed across and in contact with the bonnet leading edge (See Figure 1.).
- For vehicles having the bonnet top surface inclined at essentially 50°, so that the straight edge makes a continuous contact or multiple contacts rather than a point contact, determine the reference line with the straight edge inclined rearwards at an angle of 40°.
- For vehicles of such shape that the bottom end of the straight edge makes first contact with the vehicle then that contact is taken to be the bonnet leading edge reference line, at that lateral position.
- For vehicles of such shape that the top end of the straight edge makes first contact with the vehicle then the geometric trace of 1000 mm wrap around distance, as defined in point 3.32, will be used as bonnet leading edge reference line at that lateral position.
- The top edge of the bumper shall also be regarded as the bonnet leading edge for this Regulation, if it is contacted by the straight edge during this procedure.
- OICA comment: In 3.7 it should be thought about how far some elements of the J-MLIT draft should be included because the GTR is addressed to 3 vehicle categories.*

- 3.7 “**Bonnet rear reference line (BRL)**” means the geometric trace of the most rearward points of contact between a 165 mm diameter sphere and the rear of the bonnet when the sphere is traversed across the bonnet while maintaining contact with the windscreen (see Figure 2.)

Where the bonnet rear reference line and the side reference line do not intersect, the bonnet rear reference line should be extended and/or modified using a semi-circular template, of radius 100 mm. The template should be made of a thin flexible sheet material that easily bends to a single curvature in any direction. The template should, preferably, resist double or complex curvature where this could result in wrinkling. The recommended material is a foam backed thin plastic sheet to allow the template to ‘grip’ the surface of the vehicle. The template should be marked up with four points ‘A’ through ‘D’, as shown in Figure 3, while the template is on a flat surface. The template should be placed on the vehicle with Corners ‘A’ and ‘B’ coincident with the side reference line. Ensuring these two corners remain coincident with the side reference line, the template should be slid progressively rearwards until the arc of the template makes first contact with the bonnet rear reference line. Throughout the process, the template should be curved to follow, as closely as possible, the outer contour of the vehicle’s bonnet top, without wrinkling or folding of the template. If the contact between the template and bonnet rear reference line is tangential and the point of tangency lies outside the arc scribed by points ‘C’ and ‘D’, then the bonnet rear reference line is extended and/or modified to follow the circumferential arc of the template to meet the bonnet side reference line, as shown in Figure 4.

If the template cannot make simultaneous contact with the bonnet side reference line at points ‘A’ and ‘B’ and tangentially with the bonnet rear reference line, or the point at which the bonnet rear reference line and template touch lies within the arc scribed by points ‘C’ and ‘D’, then additional templates should be used where the radii are increased progressively in increments of 20 mm, until all the above criteria are met.

- 3.8 “**Bonnet top**” is the area which is bounded by (a), (b) and (c) as follows:
- the bonnet leading edge reference line, as defined in paragraph 3.6;
 - the bonnet rear reference line as defined in paragraph 3.7;
 - the bonnet side reference lines as defined in paragraph 3.24.

- 3.9 “**Bumper**” means the front, lower, outer structure of a vehicle. It includes all structures that are intended to give protection to a vehicle when involved in a low speed frontal collision with another vehicle and also any attachments to this structure. The reference height and lateral limits of the bumper are identified by the corners and the bumper reference lines as defined in points 3.12, 3.18, 3.19, 3.28 and 3.29.
- 3.10 “**Bumper lead**” for any section of a car is the horizontal distance in the vehicle longitudinal plane between the upper bumper reference line, as defined in point 3.29 and the bonnet leading edge reference line, as defined in point 3.6.
- 3.11 “**Child Head form Test Area**” means the outer surfaces of the front structure, ~~the windscreen, the A-pillars and the windscreen header~~ as defined in paragraph 3.14. ~~that are~~ It is bounded, in the front, by the front reference line for child headform, defined in paragraph 3.13, and, at the rear, by the rear reference line for child headform, as defined in paragraph 3.22, and by the side reference lines as defined in paragraph 3.24. In case the WAD1700 line, defined in 3.32, is located in the windscreen test area, see 3.36, at any point, the child headform test area is bounded by the WAD1700 line at the rear.
EU Comment: Could read as follows:
“Child Headform Test Area” means certain outer surfaces of the front structure, as defined in paragraph 3.14.
The area is bounded, in the front, by the front reference
EU Comment: The comment in blue would be best placed in 3.22 (corrected).
- 3.12 “**Corner of bumper**” means the vehicle’s point of contact with a vertical plane which makes an angle of 60° with the vertical longitudinal plane of the car and is tangential to the outer surface of the bumper (see Figure 3 5.).
- 3.13 “**Front reference line for Child Headform (CFL)**” means the geometric trace as described on the vehicle front structure using a wrap around distance of 1000 mm. In the case of vehicles where the wrap around distance to the bonnet leading edge reference line, as defined in paragraph 3.6, is more than 1000 mm at any point, then the bonnet leading edge reference line will be used as the front reference line for child headform at that point.
- 3.14 “**Front structure**” means all parts of the vehicle including the windscreen, the windscreen header, the A-pillars and all parts of the vehicle forward of these. It therefore includes, but is not limited to, the bonnet, wings, scuttle (cowl), wiper spindles, windscreen and lower windscreen frame.
- 3.15 “**Ground reference plane**” means a horizontal plane, either real or imaginary, that passes through the lowest points of contact for all tyres of a vehicle while the vehicle is in its normal ride attitude. If the vehicle is resting on the ground, then the ground plane and the ground reference plane are one and the same. If the vehicle is raised off the ground such as to allow extra clearance below the bumper, then the ground reference plane is above the ground plane.
- 3.16 “**Head Injury Criterion (HIC)**” means the calculated result of accelerometer time histories using the following formula:

$$\text{HIC} = \left[\frac{1}{t_2 - t_1} \int_{t_1}^{t_2} a \, dt \right]^{2.5} (t_2 - t_1)$$

Where:

- a is the resultant acceleration measured in units of gravity “g” ($1g = 9.81m/s^2$);
- t_1 and t_2 are the two time instants (expressed in seconds) during the impact, defining an interval between the beginning and the end of the recording period for which the value of HIC is a maximum ($t_2 - t_1 \leq 15$ msec)

- 3.17 “**Impact point**” means the point on the vehicle where initial contact by the test impactor occurs. The proximity of this point to the target point is dependent upon both the angle of travel by the test impactor and the contour of the vehicle surface (see point B on Figure 4.).
- 3.18 “**Lower bumper height**” means the vertical distance between the ground and the lower bumper reference line, defined in point 3.19, with the vehicle positioned in its normal ride attitude.
- 3.19 “**Lower bumper reference line**” means the lower limit to significant points of pedestrian contact with the bumper. It is defined as the geometric trace of the lowermost points of contact between a straight edge 700 mm long and the bumper, when the straight edge, held parallel to the vertical longitudinal plane of the car and inclined forwards by 25°, is traversed across the front of the car, while maintaining contact with the ground and with the surface of the bumper (see Figure 7.).
- 3.20 “**Normal ride attitude**” means the vehicle attitude in driving order positioned on the ground, with the tyres inflated to [manufacturer](#) recommended pressures, the front wheels in the straight-ahead position, with maximum capacity of all fluids necessary for operation of the vehicle [for use on public roads](#), with all standard equipment as provided by the vehicle manufacturer, with a 75 kg mass placed on the driver’s seat , and with a 75 kg mass placed on the front passenger’s seat , and the suspension set in normal running condition as specified by the manufacturer (especially for vehicles with an active suspension or a device for automatic levelling).
OICA comment: 3.20 is to be checked with the IHRA definitions, especially as regards manufacturer recommended settings.
- 3.21 “**Rear reference line for Adult Headform (ARL)**” means a geometric trace as described on the front structure of the vehicle using a wrap around distance of 2100mm.

In the case of vehicles where the wrap around distance to the rear windscreen reference line, as defined in paragraph 3.23, is less than 2100mm at any point, the rear windscreen reference line will be used as the rear reference line for the adult headform at that point.

~~In the case of vehicles For vehicles where the vertical limit reference line, wrap around distance to the rear reference line for the adult headform is over the vertical limit reference line, as defined in paragraph 3.31, is not over the wrap around distance of 2100 mm or the rear windscreen reference line, at any point, then the vertical limit reference line will be used as the rear reference line for the adult headform at that point.~~

OICA comment: In the definition of the ARL the ARL should not referred to (circular reference).

EU Comment: Could read as:

“In the case of vehicles where the wrap around distance of 2100mm is above the vertical limit reference line, as defined in paragraph 3.31, at any point, then the vertical limit reference line will be used as the rear reference line for the adult headform at that point.”

- 3.22 “**Rear reference line for Child Headform (CRL)**” means a geometric trace as described on the vehicle front structure by a wrap around distance of 1700 mm. In the case of vehicles where the wrap around distance to the bonnet rear reference line, as defined in paragraph 3.7, is less than 1700 mm at any point, then the bonnet rear reference line will be used as the rear reference line for the child headform at that point.
- 3.23 ~~“**Rear windscreen reference line (RWL)**” means the geometric trace of the most forward points of contact between a sphere and the windscreen, when a sphere of diameter 165mm is traversed across the windscreen header, including any trim, while maintaining contact with the windscreen (see Figure 8.).~~
TO BE WORDED, see Figure 13a.
OICA comment: preliminary agreed on 6. GTR meeting.
[EU Comment: This definition and those of 3.34 and 3.35 indeed require more discussion and agreement.](#)
- 3.24 “**Side reference line (SL)**” means the geometric trace of the highest points of contact between a straight edge 700 mm long and the sides of the front structure, A-pillars or roof, when the straight edge, held parallel to the transverse vertical plane of the vehicle and inclined inwards by 45° is traversed down the sides of the front structure, A-pillars or roof, while maintaining contact with the surface of the body shell (see Figure 9.).
- 3.25 “**Target Point**” means the intersection of the projection of the headform longitudinal axis with the front surface of the vehicle (see point A on Figure 6).
- 3.26 “**Third of the bonnet top**” means the geometric trace between the bonnet side reference lines, as defined in point 3.24, measured with a flexible tape following the outer contour of the bonnet top, divided into three equal parts.
- 3.27 “**Third of the bumper**” means the geometric trace between the corners of the bumper, as defined in point 3.12, measured with a flexible tape following the outer contour of the bumper, divided into three equal parts.
- 3.28 “**Upper bumper height**” means the vertical distance between the ground and the upper bumper reference line, defined in point 3.29, with the vehicle positioned in its normal ride attitude.
- 3.29 “**Upper bumper reference line**” means the upper limit to significant points of pedestrian contact with the bumper. It is defined as the geometric trace of the uppermost points of contact between a straight edge 700 mm long and the bumper, when the straight edge, held parallel to the vertical longitudinal plane of the car and inclined rearwards by 20°, is traversed across the front of the car, while maintaining contact with the ground and with the surface of the bumper (see Figure 10.). Where necessary the straight edge shall be shortened to avoid any contact with structures above the bumper.
- 3.30 “**Vehicle mass**” means the mass of the vehicle in full driving order, with the maximum capacity of all fluids necessary for the operation of the vehicle, fitted with the standard equipment as provided by the vehicle manufacturer and with no driver or passengers on board.

- [Note: This definition may change with reference to the development of the expected resolution to be agreed to the 1998 agreement concerning the definition of categories of vehicle. If this resolution is accepted then the definition could be as follows:
- 3.30 “**Vehicle mass**” means the mass of the vehicle in full driving order **or running order** as defined in Resolution no. xxx to the 1998 Agreement.
[EU Comment: This definition can only be either ‘driving order’ or ‘running order’.](#)
- 3.31 “**Vertical limit reference line (VLL)**” means a horizontal line on the vehicle at a vertical height of 1900mm from the ground reference plane (see Figure 11).
- 3.32 “**Wrap Around Distance (WAD)**” is the geometric trace described on the frontal upper surface by one end of a flexible tape, when it is held in a vertical fore and aft plane of the vehicle and traversed across the front surfaces of the bonnet and bumper. The tape is held taut throughout the operation with one end held at ground reference level, vertically below the front face of the bumper and the other end held in contact with the frontal upper surface (see Figure 12.). The vehicle is positioned in the normal ride attitude.
 This procedure shall be followed, using alternative tapes of appropriate lengths, to describe **wrap around distances** of 1000 mm (**WAD1000**), of 1700 mm (**WAD1700**) and of 2100 mm (**WAD2100**) ~~wrap around distances~~.
- 3.33 “**Windscreen**” means the frontal glazing of the vehicle situated between the A-pillars.
- 3.34 “**Windscreen side reference line (SWL)**” ~~means the geometric trace of the most outward points of contact between a sphere and the windscreen, when a sphere of diameter 165mm is rolled down the A pillar, including any trim, while maintaining contact with the windscreen.~~
TO BE WORDED, see Figure 13b.
OICA comment: preliminary agreed on 6. GTR meeting.
[EU Comment: This definition and those of 3.23 and 3.35 indeed require more discussion and agreement.](#)
- 3.35 “**Windscreen lower reference line (LWL)**” ~~means the geometric trace of the uppermost points of contact between a sphere and the windscreen, when a sphere of diameter 165mm is traversed across the rear edge of the bonnet, while maintaining contact with the windscreen.~~
TO BE WORDED, see Figure 13c.
OICA comment: preliminary agreed on 6. GTR meeting.
[EU Comment: This definition and those of 3.23 and 3.34 indeed require more discussion and agreement.](#)
- 3.36 “**Windscreen test area**” means an area of the windscreen bordered as follows:
- towards the windscreen top, by a line 82.5 mm forwards of the rear windscreen reference line as defined in paragraph 3.23.
 - towards each windscreen side, by a line 82.5 mm inside the windscreen side reference line as defined in paragraph 3.34.
 - towards the base of the windscreen, by a line 82.5 mm inside the windscreen lower reference line as defined in paragraph 3.35.
- (See Figure 13)

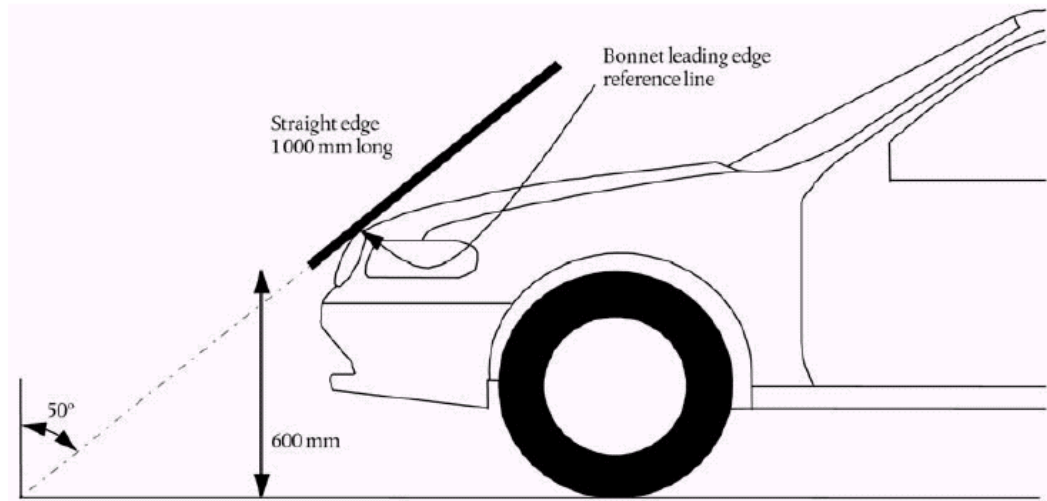

Figure 1: Bonnet Leading Edge Reference Line.

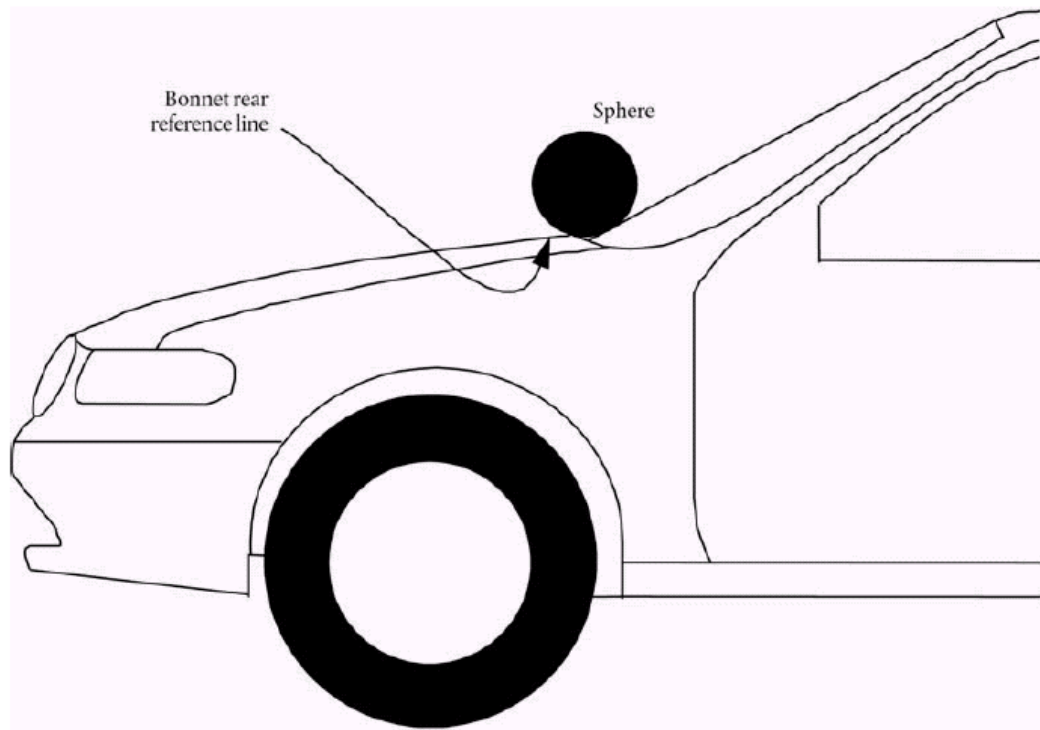

Figure 2: Bonnet Rear Reference Line.

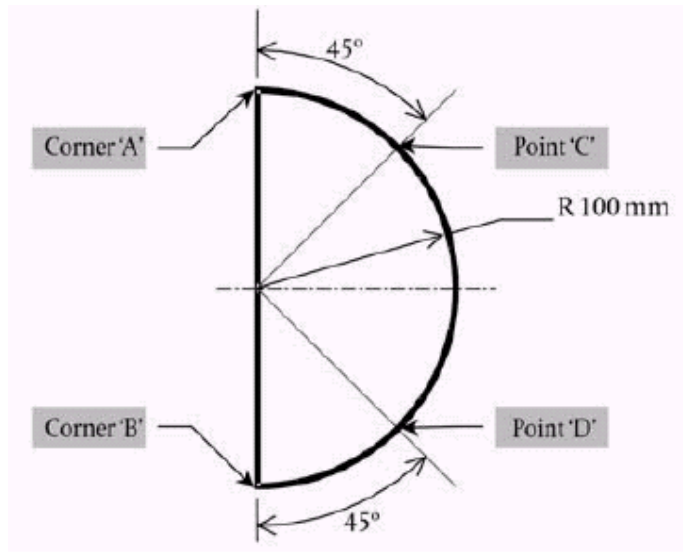

Figure 3: Template.

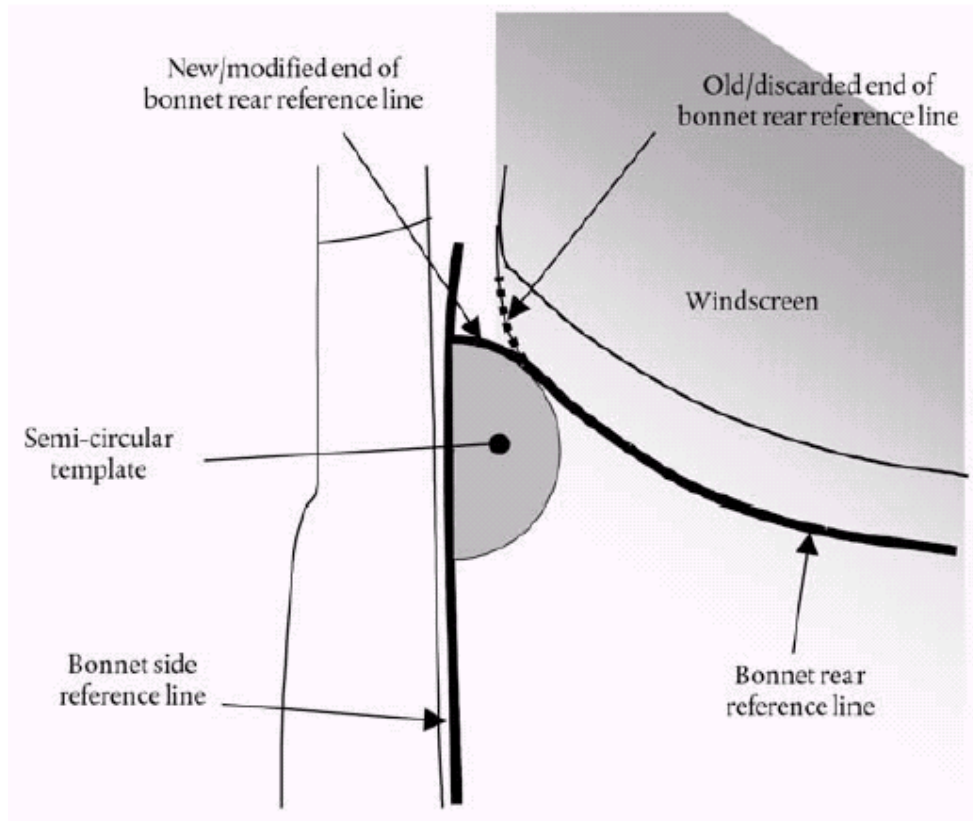

Figure 4: Marking of intersection between bonnet rear and side reference lines.

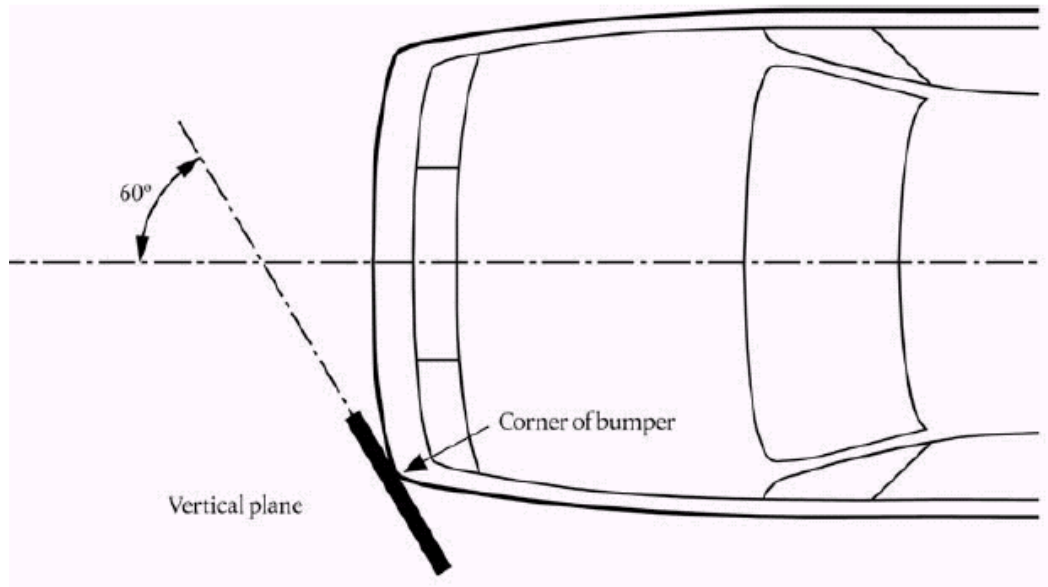
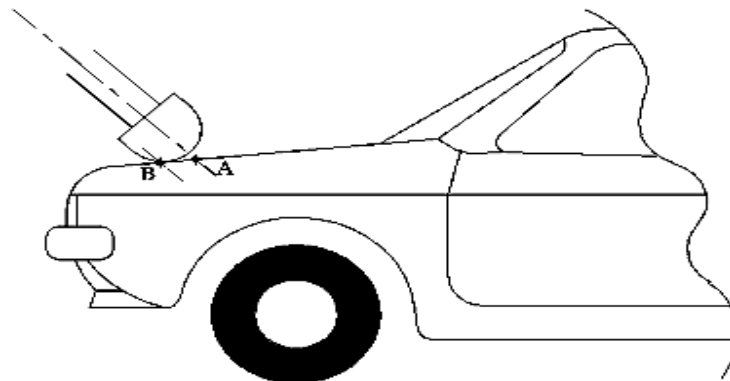

Figure 5: Corner of Bumper



A: Target Point
B: Impact Point

Figure 6: Impact Point.

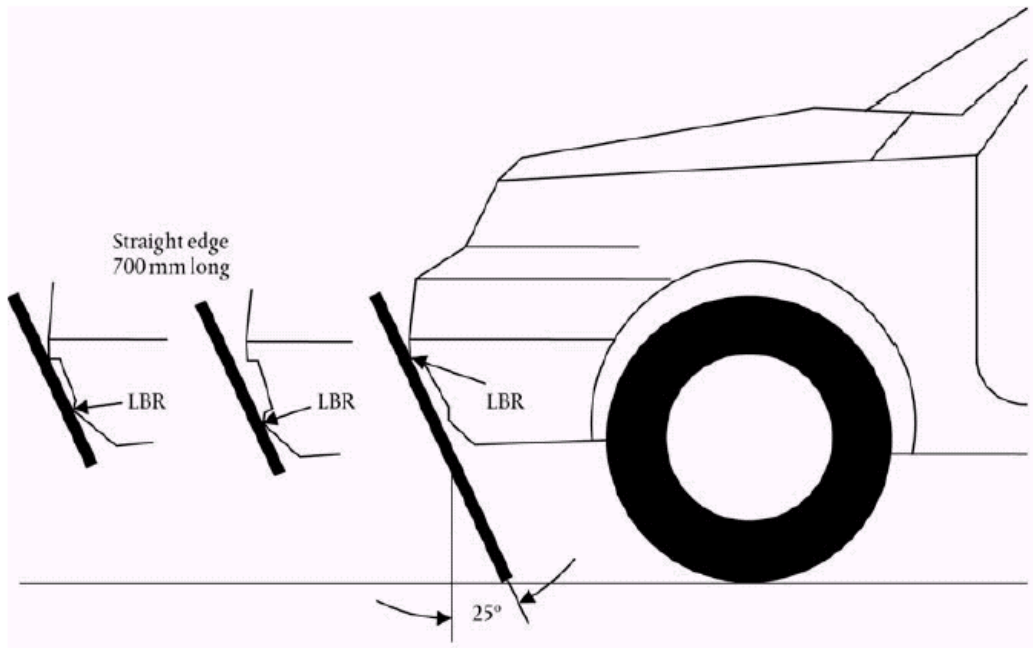

Figure 7: Lower Bumper Reference Line.

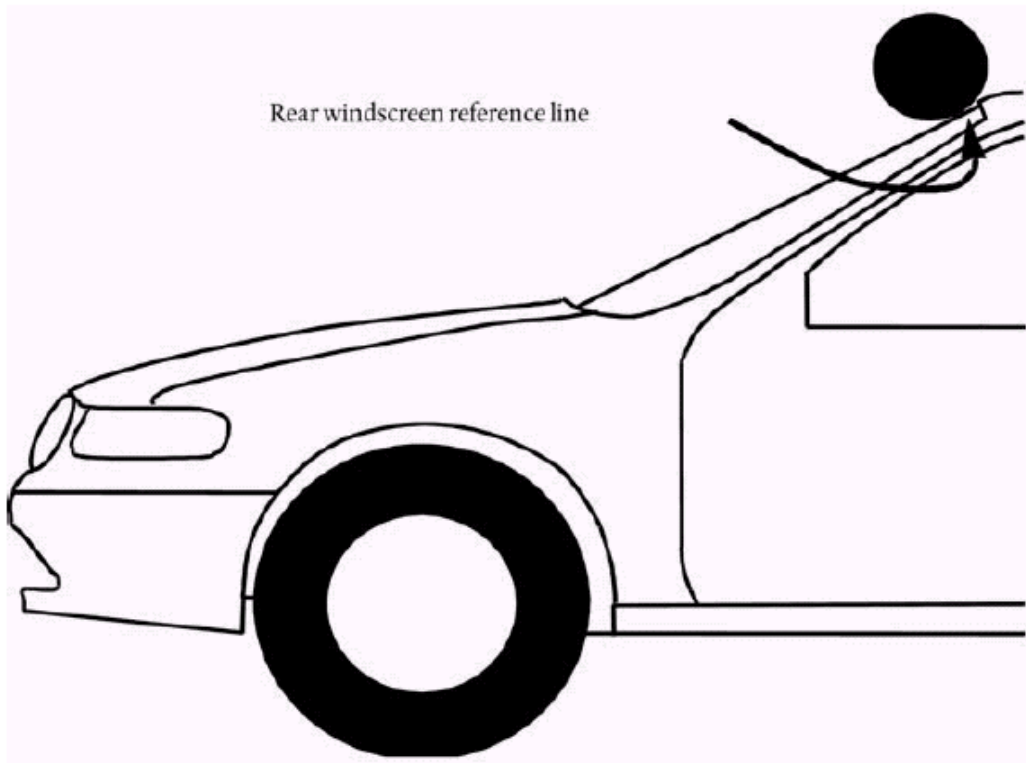

Figure 8: Rear Windscreen Reference Line.

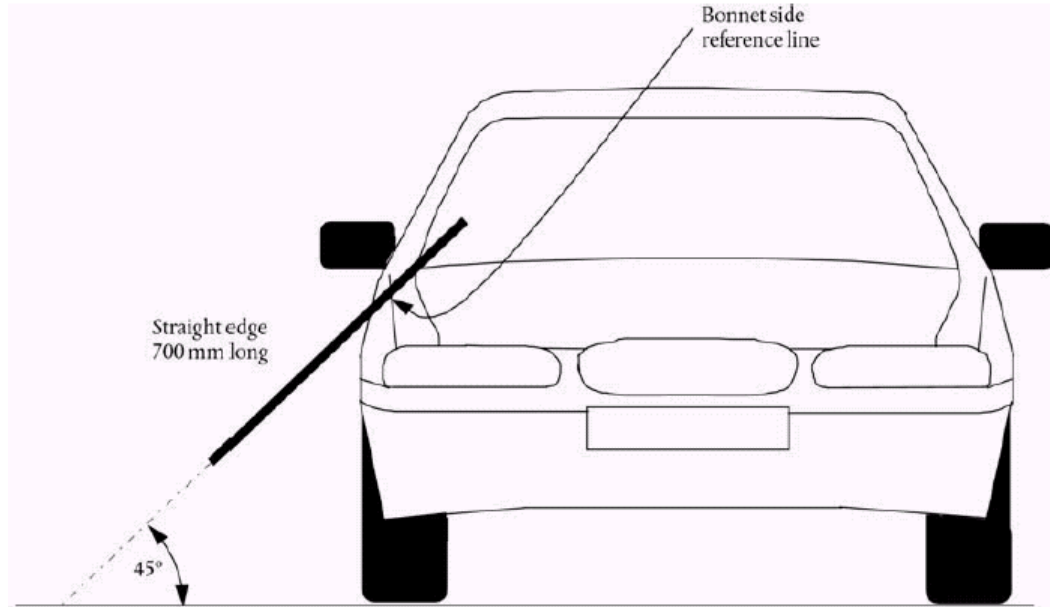

Figure 9: Side Reference Line.

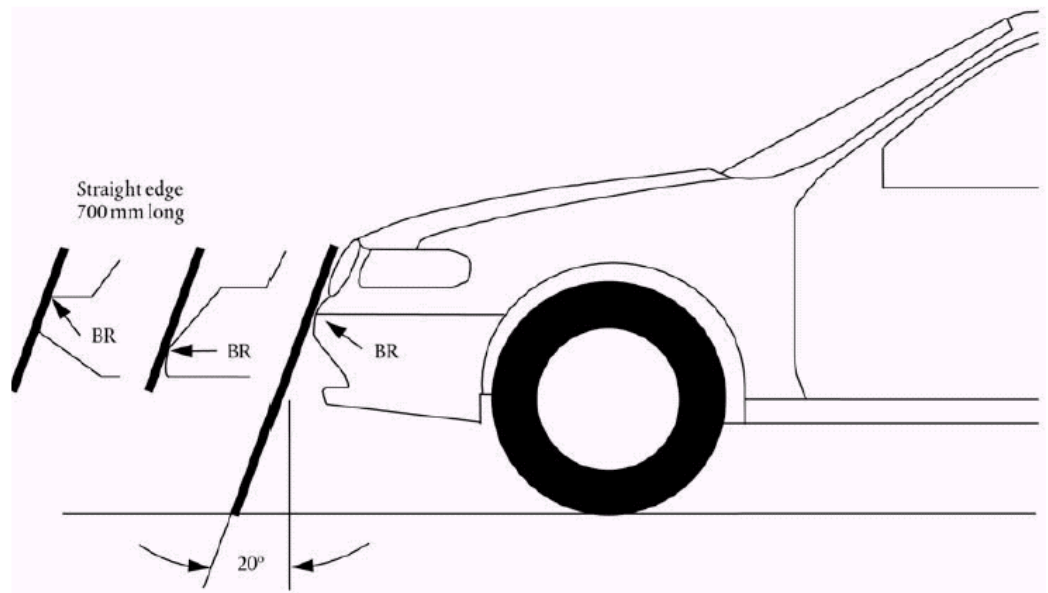

Figure 10: Upper Bumper Reference Line.

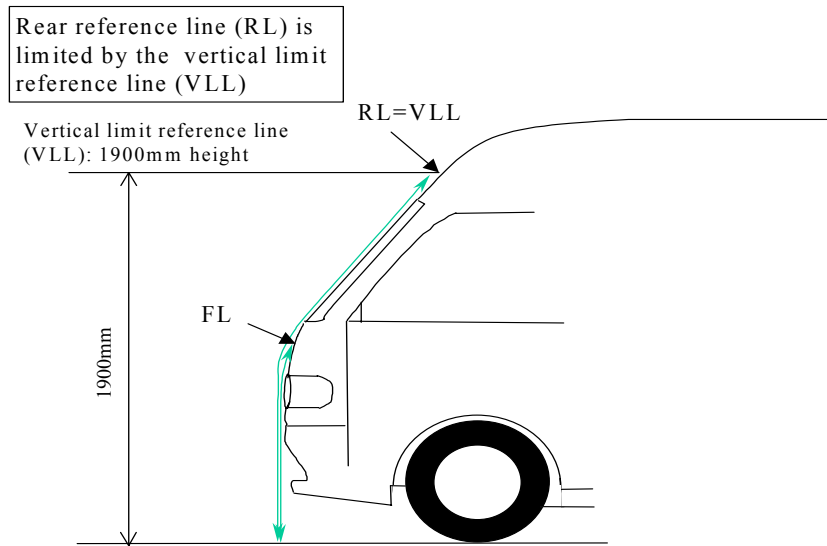

Figure 11: Vertical limit reference line.

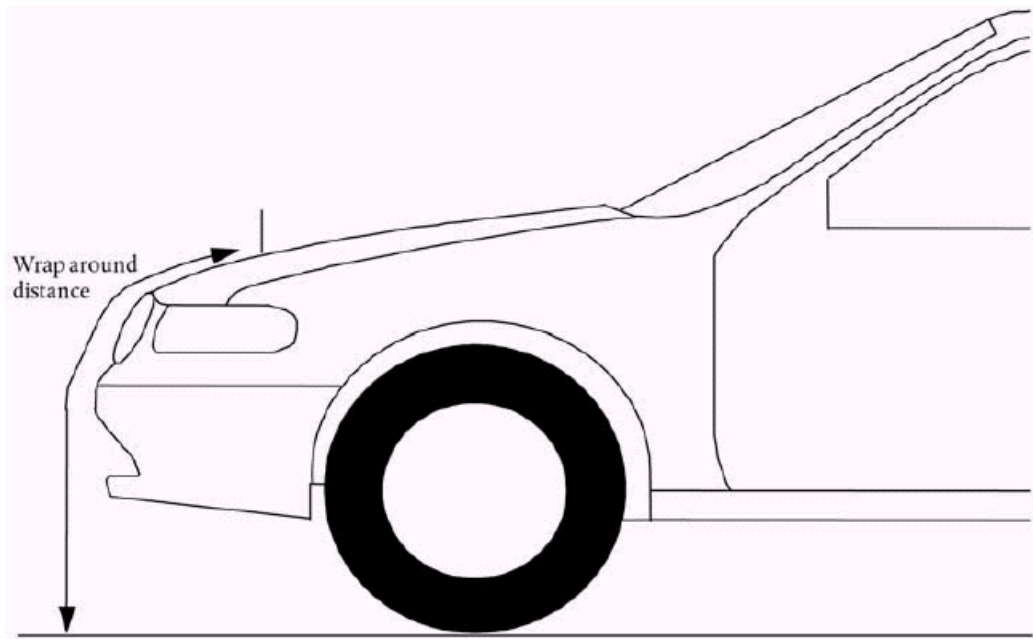

Figure 12: Wrap Around Distance Measurement.

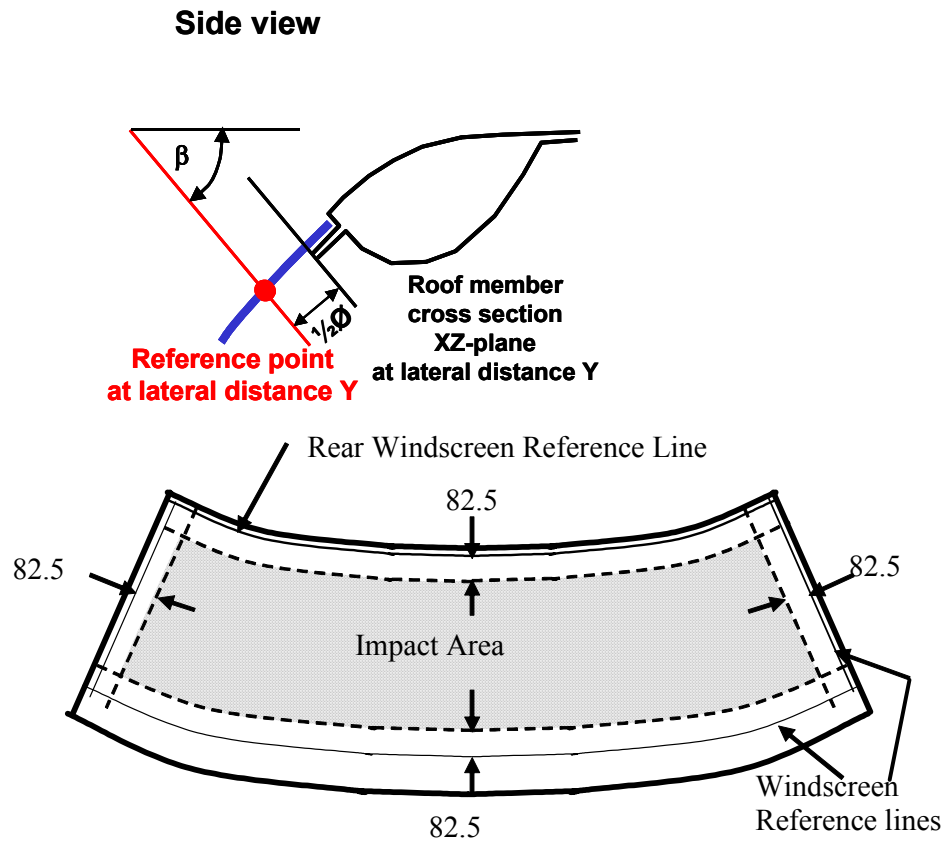

Figure 13: Windscreen test area.

Figure 13a: windscreen rear reference line

EU Comment: This diagram requires more discussion and agreement.

Top view

INF GR / PS / 86 / Rev 2 + PS / 88

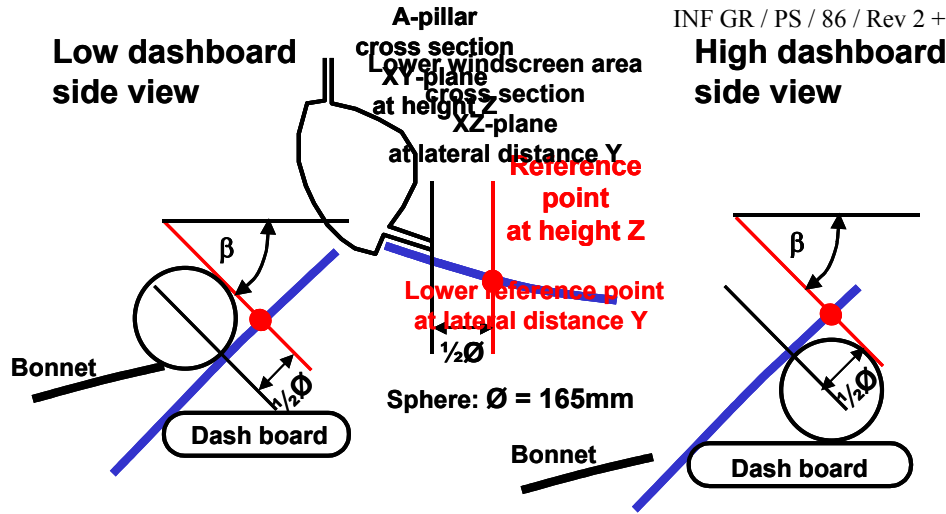

Figure 13b: windscreen side reference line

[EU Comment: This diagram requires more discussion and agreement.](#)

Figure 13c: windscreen lower reference line

[EU Comment: This diagram requires more discussion and agreement.](#)

4. General Requirements.

This Global Technical Regulation specifies the following tests to verify compliance of vehicles

[Comment: The group agreed that inclusion of the upper leg test to the bonnet leading edge needed further review. In particular, it must be verified whether this test is actually needed on the basis of accident data, technical feasibility, test procedure repeatability, reproducibility, etc. The group however agreed not to include this test for the time being, but also agreed to review this issue at a later stage on the basis of any new available information.]

4.1 Legform test to bumper:

One of the following legform tests are required to be performed:

4.1.1 Lower leg form to bumper:

To comply with the performance requirements as specified in section 5.1.1, the test conditions specified in sections 6.1 and 6.3.1.1 and the test procedures specified in section 7.1.1.

4.1.2 Upper legform to bumper:

To comply with the performance requirements as specified in section 5.1.2, the test conditions specified in sections 6.1 and 6.3.1.2 and the test procedures specified in section 7.1.2.]

4.2 Child headform impact:

To comply with the performance requirements as specified in section 5.2.1 and 5.2.3, the test conditions specified in sections 6.1 and 6.3.2.1 and the test procedures specified in section 7.2.

4.3 Adult headform impact:

To comply with the performance requirements as specified in section 5.2.2 and 5.2.3, the test conditions specified in sections 6.1 and 6.3.2.2 and the test procedures specified in section 7.3.

5. Performance Requirements.

5.1 Legform to Bumper:

5.1.1 When tested in accordance with section 7.1.1 (lower legform to bumper), the maximum dynamic knee bending angle shall not exceed [21.0°], the maximum dynamic knee shearing displacement shall not exceed [6.0mm], and the acceleration measured at the upper end of the tibia shall not exceed [200g]

[Note: The following alternative may be required if a decision is agreed to use the flexible legform impactor now being developed;

5.1.1 When tested in accordance with section 7.1.1 (lower legform to bumper), the maximum dynamic knee bending angle shall not exceed [20.0°], ~~the maximum dynamic knee shearing displacement shall not exceed [6.0mm], the acceleration~~

~~measured at the upper end of the tibia shall not exceed [200g] and the tibia bending moment shall not exceed [350]Nm.~~

OICA comment: Only two thresholds were tentatively agreed during the 6th GTR session.

5.1.2 When tested in accordance with section 7.2.1 (Upper legform to bumper), the instantaneous sum of the impact forces with respect to time shall not exceed [7.5kN] and the bending moment on the test impactor shall not exceed [510Nm].

5.2 Headform tests

5.2.1 Child headform to front structure:

When tested in accordance with section 7.2 the Head Injury Criterion (HIC) shall not exceed [1000]⁽¹⁾ over the ~~child headform test area~~ **bonnet top** as defined in paragraph ~~3.4~~ **3.8**. For impact points in the windscreen **test area**, the requirements of paragraph 5.2.3 shall apply.

[EU Comment: The reference to the child headform test area, as defined in paragraph 3.11, should remain.](#)

5.2.2 Adult head form to the front structure:

When tested in accordance with section 7.3 the Head Injury Criterion (HIC) shall not exceed [1000]⁽¹⁾ over the ~~adult headform test area~~ **bonnet top** as defined in paragraph ~~3.4~~ **3.8**. For impact points in the windscreen **test area**, the requirements of paragraph 5.2.3 shall apply.

[EU Comment: The reference to the adult headform test area, as defined in paragraph 3.11, should remain.](#)

[Footnote: ⁽¹⁾ the group agreed that the area required to meet HIC 1000 may need revision and some consideration given to allow some exemption zones.]

5.2.3 [If the tested front structure as impacted by the child or adult headforms includes parts of the windscreen ~~area~~, **as defined in 3.33**, the Head Injury Criterion (HIC) shall not exceed 1000 for all the selected impact points within the windscreen test area, defined in paragraph 3.36.]

6. **Test Conditions**

6.1 General Site Conditions

6.1.1 Temperature and humidity

The stabilised temperature of the test tools and of the vehicle or sub-system at the time of testing shall be [20° ± 4°]C. The relative humidity of the test area where all equipment is held should be [10 to 70]% after a stabilised period of at least four hours prior to the application of any test.

6.1.1.1 Sufficient time must be allowed before testing for the temperature of all vehicle components to stabilise to the required temperature range.

6.1.1.2 Relative humidity and temperature shall be measured at the time of the test, and recorded in the test report.

6.1.2 Impact test site

The test site shall consist of a flat, smooth and hard surface with a slope not exceeding 1 %.

6.2 Preparation of the vehicle

- 6.2.1 Either a complete vehicle or a cut-body adjusted to the following conditions, shall be used for the test.
- 6.2.1.1 The vehicle shall be in its normal ride attitude and shall be either securely mounted on raised supports or at rest on a flat surface. The parking brake shall be applied, or the cut-body shall be securely mounted.
- 6.2.1.2 The cut-body shall include all parts of the vehicle front structure and under bonnet components, or behind windscreen components, that may be involved in a frontal impact with a vulnerable road user in the test, to demonstrate the performance and interactions of all the contributory vehicle components.
- 6.2.1.2.1 The cut-body shall be securely mounted in the normal vehicle ride attitude.
- 6.2.2 All devices designed to protect vulnerable road users shall be correctly activated before and/or be active during the appropriate test. It shall be the responsibility of the manufacturer to show that any devices will act as intended in a pedestrian impact.
- 6.2.3 Any vehicle component which could change shape or position, such as 'pop-up' headlights, other than active devices to protect pedestrians, shall be set to a shape or position that the test institutes in consultation with the manufacturer consider to be the most appropriate for these tests.
- 6.3 Test impactor specifications
- 6.3.1 Legform impactors:
- [Note: The following description of the lower legform impactor is based on the presently known and used impactor. The further development and acceptance of a flexible legform impactor may require the complete replacement of the following section 6.3.1.1.]**
- 6.3.1.1 Lower legform impactor:
- The lower legform impactor shall consist of two foam covered rigid segments, representing femur (upper leg) and tibia (lower leg), joined by a deformable, simulated knee joint. The overall length of the impactor shall be 926 ± 5 mm, having a required test mass of $13,4 \pm 0,2$ kg (see Figure 14). Brackets, pulleys, etc. attached to the impactor for the purpose of launching it, may extend the dimensions shown in Figure 14.
- 6.3.1.1.1 The diameter of the femur and tibia shall be 70 ± 1 mm and both shall be covered by foam 'flesh' and skin. The foam flesh shall be 25 mm thick Confor™ foam type CF-45. The skin shall be made of neoprene foam, faced with ½ mm thick nylon cloth both sides, with an overall thickness of 6 mm.
- 6.3.1.1.2 The 'centre of the knee' is defined as the point about which the knee effectively bends.
- 6.3.1.1.3 The 'femur' is defined as all components or parts of components (including flesh, skin covering, damper, instrumentation and brackets, pulleys, etc. attached to the impactor for the purpose of launching it) above the level of the centre of the knee.
- 6.3.1.1.4 The 'tibia' is defined as all components or parts of components (including flesh, skin

covering, instrumentation and brackets, pulleys, etc. attached to the impactor for the purpose of launching it) below the level of the centre of the knee. Note that the tibia as defined includes allowances for the mass, etc., of the foot.

- 6.3.1.1.5 The total mass of the femur and tibia shall be $8,6 \pm 0,1$ kg and $4,8 \pm 0,1$ kg respectively, and the total mass of the impactor shall be $13,4 \pm 0,2$ kg. The centre of gravity of the femur and tibia shall be 217 ± 10 mm and 233 ± 10 mm from the centre of the knee respectively. The moment of inertia of the femur and tibia, about a horizontal axis through the respective centre of gravity and perpendicular to the direction of impact, shall be $0,127 \pm 0,010$ kg/m² and $0,120 \pm 0,010$ kg/m² respectively.
- 6.3.1.1.6 The impactor shall be fitted with foam flesh cut from one of up to four consecutive sheets of Confor™ foam flesh material produced from the same batch of manufacture (cut from one block or bun of foam), provided that foam from one of these sheets was used in the dynamic certification test and the individual weights of these sheets are within ± 2 % of the weight of the sheet used in the certification test.
- 6.3.1.1.7 Lower legform instrumentation
- 6.3.1.1.7.1 A uniaxial accelerometer shall be mounted on the non-impacted side of the tibia, 66 ± 5 mm below the knee joint centre, with its sensitive axis in the direction of impact.
- 6.3.1.1.7.2 The impactor shall be instrumented to measure the bending angle and the shearing displacement between femur and tibia.
- 6.3.1.1.7.3 A damper shall be fitted to the shear displacement system and may be mounted at any point on the rear face of the impactor or internally. The damper properties shall be such that the impactor meets both the static and dynamic shear displacement requirements and prevents excessive vibrations of the shear displacement system.
- 6.3.1.1.7.4 Transducers shall be fitted to measure knee bending angle and knee shearing displacement. One uni-axial accelerometer shall be fitted to the non-impacted side of the tibia, close to the knee joint, with its sensitive axis in the impact direction.
- 6.3.1.1.7.5 The instrumentation response value CFC, as defined in ISO 6487:2000, shall be 180 for all transducers. The CAC response values, as defined in ISO 6487:2000, shall be 50° for the knee bending angle, 10 mm for the shearing displacement and 500 g for the acceleration. This does not require that the impactor itself be able to physically bend and shear to these angles and displacements.
- 6.3.1.1.8 Lower legform certification
- 6.3.1.1.8.1 The lower legform impactor shall meet the performance requirements specified in section 8, and shall be fitted with deformable knee elements from the same batch as those used in the certification tests.
- 6.3.1.1.8.2 The certified impactor may be used for a maximum of 20 impacts before re-certification. With each test new plastically deformable knee elements should be used. The impactor shall also be re-certified if more than one year has elapsed since the previous certification or if any impactor transducer output, in any impact, has exceeded the specified CAC.
- 6.3.1.1.9 The lower legform impactor for the bumper tests shall be in 'free flight' at the moment

of impact. The impactor shall be released to free flight at such a distance from the vehicle that the test results are not influenced by contact of the impactor with the propulsion system during rebound of the impactor.

The impactor may be propelled by an air, spring or hydraulic gun, or by other means that can be shown to give the same result.

OICA comment: It appears that chapter 6.3.1.1.9 is more related to the test procedure in 7.1.1.

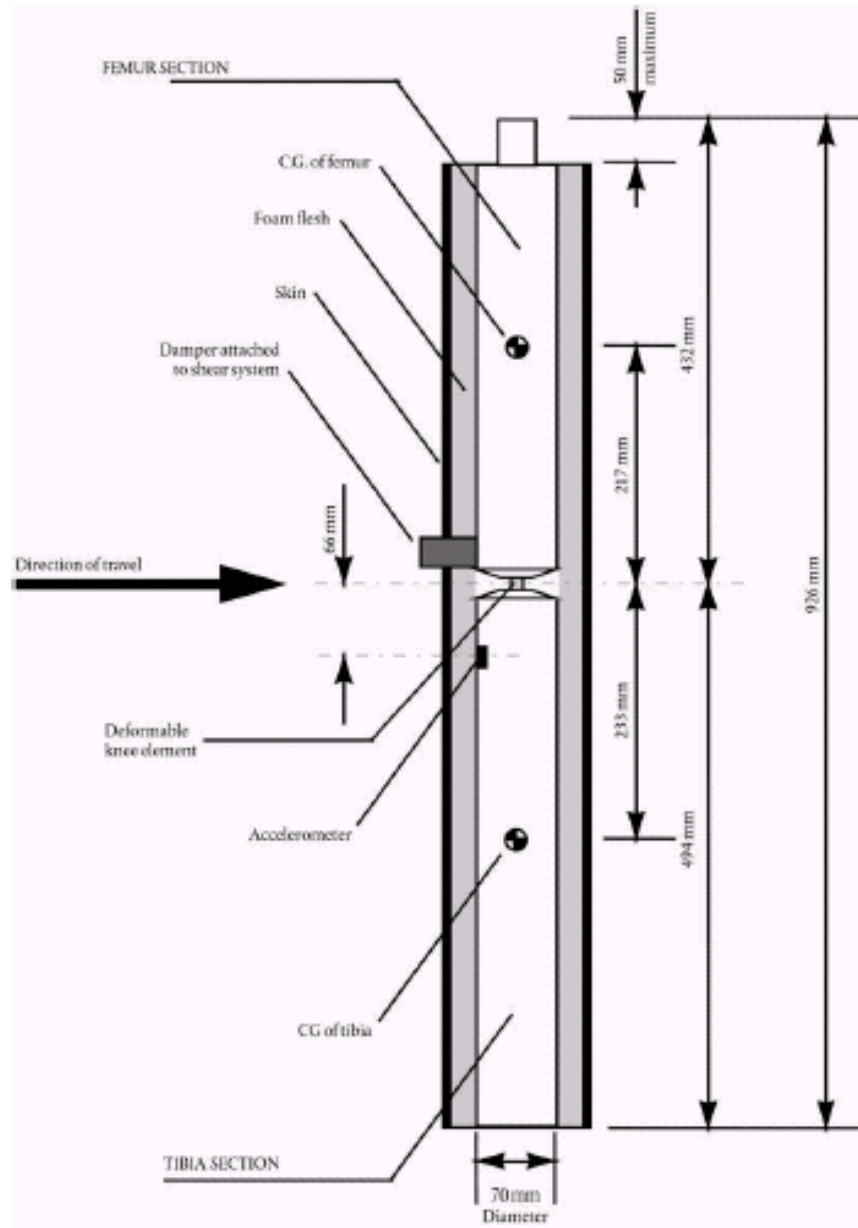

Figure 14: Lower legform impactor.

6.3.1.2 [Upper legform impactor:

The upper legform impactor shall be rigid, foam covered at the impact side, and 350 ± 5 mm long (see Figure 15).

6.3.1.2.1 The total mass of the upper legform impactor including those propulsion and guidance components which are effectively part of the impactor during the impact shall be 9,5

kg \pm 0,1 kg. The upper legform impactor mass may be adjusted from this value by up to \pm 1 kg, provided the required impact velocity is also changed using the formula:

$$V = \sqrt{1\ 170/M}$$

Where:

V = impact velocity (m/s)

M = mass (kg), measured to an accuracy of better than \pm 1 %

- 6.3.1.2.2 The total mass of the front member and other components in front of the load transducer assemblies, together with those parts of the load transducer assemblies in front of the active elements, but excluding the foam and skin, shall be $1,95 \pm 0,05$ kg.
- 6.3.1.2.3 The torque limiting joint shall be set so that the longitudinal axis of the front member is perpendicular to the axis of the guidance system, with a tolerance of $\pm 2^\circ$, with the joint friction torque set to a minimum of 650 Nm.
- 6.3.1.2.4 The centre of gravity of those parts of the impactor which are effectively forward of the torque limiting joint, including any weights fitted, shall lie on the longitudinal centre line of the impactor, with a tolerance of ± 10 mm.
- 6.3.1.2.5 The length between the load transducer centre lines shall be 310 ± 1 mm and the front member diameter shall be 50 ± 1 mm.
- 6.3.1.2.6 The foam flesh shall be two sheets of 25 mm thick Confor™ foam type CF-45. The skin shall be a 1,5 mm thick fibre reinforced rubber sheet. The foam and rubber skin together shall weigh $0,6 \pm 0,1$ kg (this excludes any reinforcement, mountings, etc. which are used to attach the rear edges of the rubber skin to the rear member). The foam and rubber skin shall be folded back towards the rear, with the rubber skin attached via spacers to the rear member so that the sides of the rubber skin are held parallel. The foam shall be of such a size and shape that an adequate gap is maintained between the foam and components behind the front member, to avoid significant load paths between the foam and these components.
- 6.3.1.2.7 Upper legform instrumentation
- 6.3.1.2.7.1 The front member shall be strain gauged to measure bending moments in three positions, as shown in Figure 15, each using a separate channel. The strain gauges are located on the impactor on the back of the front member. The two outer strain gauges are located 50 ± 1 mm from the impactor's symmetrical axis. The middle strain gauge is located on the symmetrical axis with a ± 1 mm tolerance.
- 6.3.1.2.7.2 Two load transducers shall be fitted to measure individually the forces applied at either end of the upper legform impactor, plus strain gauges measuring bending moments at the centre of the upper legform impactor and at positions 50 mm either side of the centre line, (see Figure 15).
- 6.3.1.2.7.3 The instrumentation response value CFC, as defined in ISO 6487:2000, shall be 180 for all transducers. The CAC response values, as defined in ISO 6487:2000, shall be 10 kN for the force transducers and 1 000 Nm for the bending moment measurements.
- 6.3.1.2.8 Upper legform certification

- 6.3.1.2.8.1 The upper legform impactor shall meet the performance requirements specified in section 8.
- 6.3.1.2.8.2 The certified impactor may be used for a maximum of 20 impacts before re-certification (this limit does not apply to propulsion or guidance components). The impactor shall also be re-certified if more than one year has elapsed since the previous certification or if any impactor transducer output, in any impact, has exceeded the specified CAC.

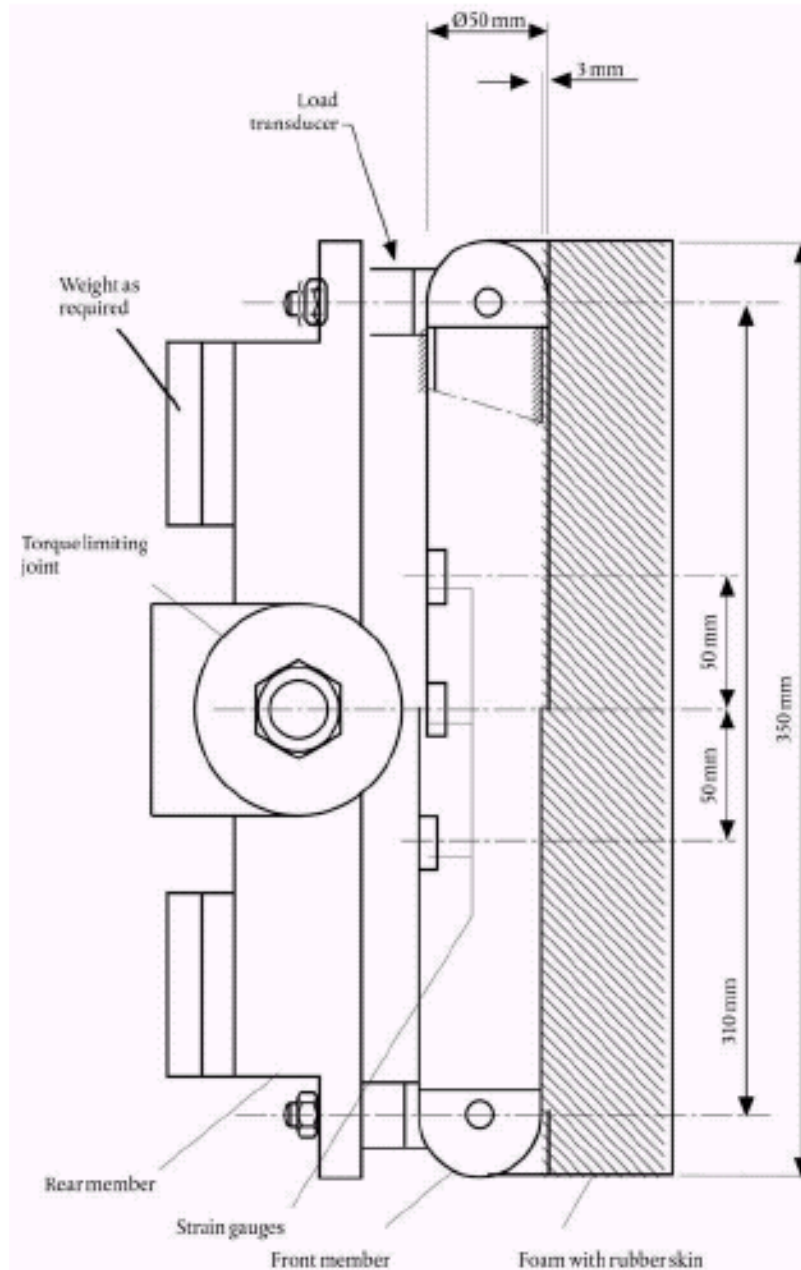

Figure 15: Upper legform impactor]

- 6.3.2 Child and Adult headforms
- 6.3.2.1 Child headform impactor

The child headform impactor shall be made of aluminium, be of homogenous construction and be of spherical shape. The diameter shall be $[165 \pm 1]$ mm as shown in Figure 16. The mass shall be $[3,5 \pm 0,07]$ kg. The moment of inertia about an axis through the centre of gravity and perpendicular to the direction of impact shall be within the range of $[0,0075 \text{ to } 0,0200]$ kgm^2 . The centre of gravity of the headform impactor including instrumentation shall be located in the geometric centre of the sphere with a tolerance of $\pm[5]$ mm.

[Note: Possibly to be corrected as per INF GR PS 74]

The sphere shall be covered with a $[13.9 \pm 0.5]$ mm thick synthetic skin, which shall cover at least half of the sphere.

6.3.2.1.2 Child headform instrumentation

A recess in the sphere shall allow for mounting one triaxial or three uniaxial accelerometers within $\pm [10]$ mm seismic mass location tolerance from the centre of the sphere for the measurement axis, and $\pm [1]$ mm seismic mass location tolerance from the centre of the sphere for the perpendicular direction to the measurement axis.

[Note: The following description may be replaced by a proposal from Japan.]

One of the accelerometers shall have its sensitive axis perpendicular to the mounting face A (see figure 16) and its seismic mass shall be positioned within a cylindrical tolerance field of 1 mm radius and 20 mm length. The centre line of the tolerance field shall run perpendicular to the mounting face and its mid-point shall coincide with the centre of the sphere of the headform impactor.

The remaining accelerometers shall have their sensitive axes perpendicular to each other and parallel to the mounting face A and their seismic mass shall be positioned within a spherical tolerance field of 10 mm radius. The centre of the tolerance field shall coincide with the centre of the sphere of the headform impactor.

The instrumentation response value CFC, as defined in ISO 6487: 2002, shall be 1000. The CAC response value, as defined in ISO 6487: 2002, shall be 500 g for the acceleration.

6.3.2.1.2 First natural frequency

The first natural frequency of the headform impactor shall be over 5000 Hz.

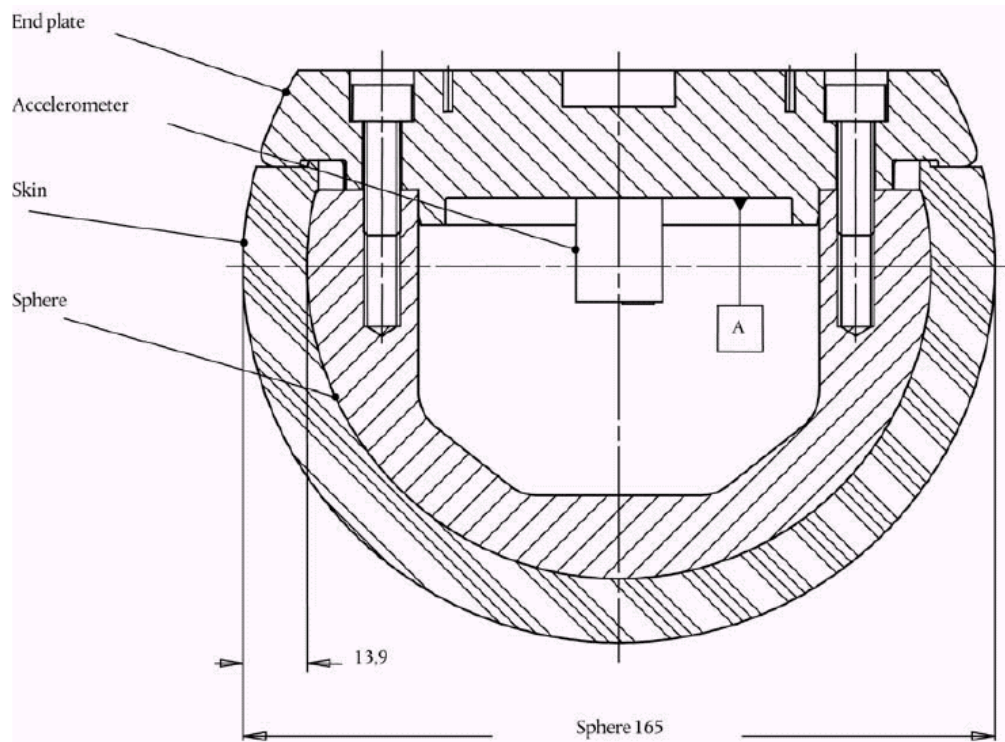

Figure 16: Child headform impactor

6.3.2.1.3 The child headform test procedures are detailed in paragraph 7.2 below.

6.3.2.2 Adult headform impactor

The adult headform impactor shall be made of aluminium, be of homogenous construction and be of spherical shape. The diameter is $[165 \pm 1]$ mm as shown in Figure 17. The mass shall be $[4,5 \pm 0,1]$ kg. The moment of inertia about an axis through the centre of gravity and perpendicular to the direction of impact shall be within the range of $[0,0075 \text{ to } 0,0200]$ kgm^2 . The centre of gravity of the headform impactor including instrumentation shall be located in the geometric centre of the sphere with a tolerance of $\pm [5]$ mm.

[Note: Possibly to be corrected as per INF GR PS 74]

The sphere shall be covered with a $[13,9 \pm 0,5]$ mm thick synthetic skin, which shall cover at least half of the sphere.

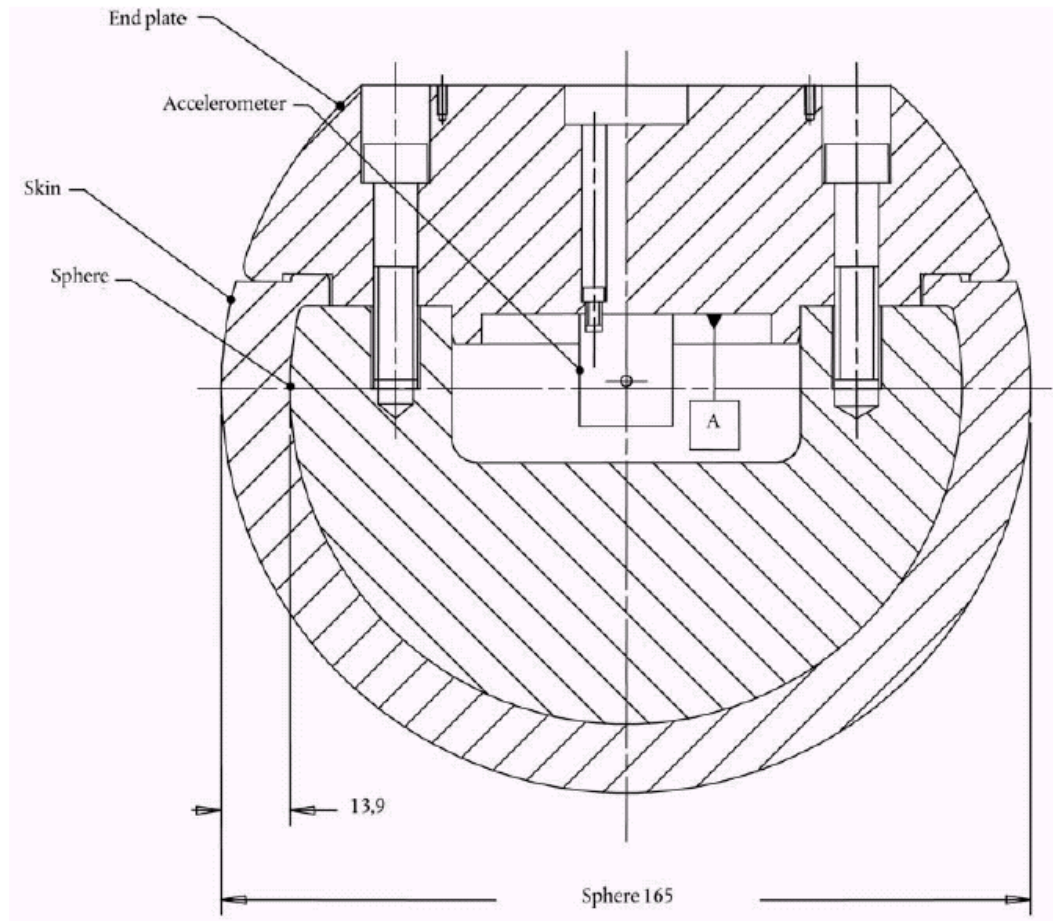

Figure 17: Adult headform impactor

6.3.2.2.1 Adult headform instrumentation

A recess in the sphere shall allow for mounting one triaxial or three uniaxial accelerometers within $\pm [10]$ mm seismic mass location tolerance from the centre of the sphere for the measurement axis, and $\pm [1]$ mm seismic mass location tolerance from the centre of the sphere for the perpendicular direction to the measurement axis.

[Note: The following description may be replaced by a proposal from Japan.]

One of the accelerometers shall have its sensitive axis perpendicular to the mounting face A (see figure 17) and its seismic mass shall be positioned within a cylindrical tolerance field of 1 mm radius and 20 mm length. The centre line of the tolerance field shall run perpendicular to the mounting face and its mid-point shall coincide with the centre of the sphere of the headform impactor.

The remaining accelerometers shall have their sensitive axes perpendicular to each other and parallel to the mounting face A and their seismic mass shall be positioned within a spherical tolerance field of 10 mm radius. The centre of the tolerance field shall coincide with the centre of the sphere of the headform impactor.

The instrumentation response value CFC, as defined in ISO 6487: 2002, shall be 1000. The CAC response value, as defined in ISO 6487: 2002, shall be 500 g for the acceleration.

6.3.2.2.2 First natural frequency

First natural frequency of the headform impactor shall be over 5000 Hz.

6.3.2.3 Rear face of the headform impactors

A rear flat face shall be provided on the outer surface of the headform impactor which is perpendicular to the direction of travel, and typically perpendicular to the axis of one of the accelerometers as well as being a flat plate capable of providing for access to the accelerometers and an attachment point for the propulsion system.

6.3.2.4 Certification of the headform impactors

The headform impactors shall meet the performance requirements specified in section 8. The certified impactor may be used for a maximum of 20 impacts before re-certification. The impactor shall be re-certified if more than one year has elapsed since the previous certification or if the transducer output, in any impact, has exceeded the specified CAC.

6.3.2.5 Propulsion of the headform impactors

The headform impactors shall be in 'free flight' at the moment of impact, at the required impact velocity (see paragraphs 7.2.5 and 7.3.5) and the required direction of impact (see sections 7.2.6 and 7.3.6).

The impactors shall be released to free flight at such a distance from the vehicle that the test results are not influenced by contact of the impactor with the propulsion system during rebound of the impactor.

6.3.2.6 Measurement of impact velocity

The velocity of the headform impactor shall be measured at some point during the free flight before impact, in accordance with the method specified in ISO 3784: 1976. The accuracy of velocity measurement shall be $\pm 0,01$ m/sec. The measured velocity shall be adjusted considering all factors which may affect the impactor between the point of measurement and the point of impact, in order to give the velocity of the impactor at the time of impact. The angle of the velocity vector at the time of impact shall be calculated or measured.

6.3.2.7 Recording

The acceleration time histories shall be recorded, and HIC shall be calculated. The first point of contact on the front structure of the vehicle shall be recorded. Recording of test results shall be in accordance with ISO 6487:2002.

7. **Test Procedures.**

7.1 Legform to Bumper Test Procedures

7.1.1 Lower leg form to bumper test procedure:

7.1.1.1 A minimum of three lower legform to bumper tests shall be carried out, one each to the middle and the outer thirds of the bumper at positions judged to be the most likely to cause injury. Tests shall be to different types of structure, where they vary throughout the area to be assessed. The selected test points shall be a minimum of 132 mm apart, and a minimum of 66 mm inside the defined corners of the bumper. These minimum distances are to be set with a flexible tape held tautly along the outer surface of the vehicle. The positions tested by the laboratories shall be indicated in the test report.

7.1.1.1.1 Manufacturers might apply for derogation concerning an exemption zone for a removable towing hook.

7.1.1.2 The direction of the impact velocity vector shall be in the horizontal plane and parallel to the longitudinal vertical plane of the vehicle. The tolerance for the direction of the velocity vector in the horizontal plane and in the longitudinal plane shall be $\pm [2]^\circ$ at the time of first contact. The axis of the impactor shall be perpendicular to the horizontal plane with a tolerance of $\pm [2]^\circ$ in the lateral and longitudinal plane. The horizontal, longitudinal and lateral planes are orthogonal to each other (see Figure 18).

7.1.1.3 The bottom of the impactor shall be at ground reference level at the time of first contact with the bumper (see Figure 19), with a $\pm [10]$ mm tolerance. When setting the height of the propulsion system, an allowance must be made for the influence of gravity during the period of free flight of the impactor.

7.1.1.3.1 At the time of first contact the impactor shall have the intended orientation about its vertical axis, for the correct operation of its knee joint, with a tolerance of $\pm [5]^\circ$ (see Figure 18).

7.1.1.3.2 At the time of first contact the centre line of the impactor shall be within a ± 10 mm tolerance to the selected impact location.

7.1.1.3.3 During contact between the impactor and the vehicle, the impactor shall not contact the ground or any object which is not part of the vehicle.

7.1.1.4 The impact velocity of the impactor when striking the bumper shall be $11,1 \pm 0,2$ m/s. The effect of gravity shall be taken into account when the impact velocity is obtained from measurements taken before the time of first contact.

OICA comment: Smaller tolerances in the above definitions of the legform impactor position at time of first contact should be checked. The sum of all tolerances might result in considerable differences of the measurement.

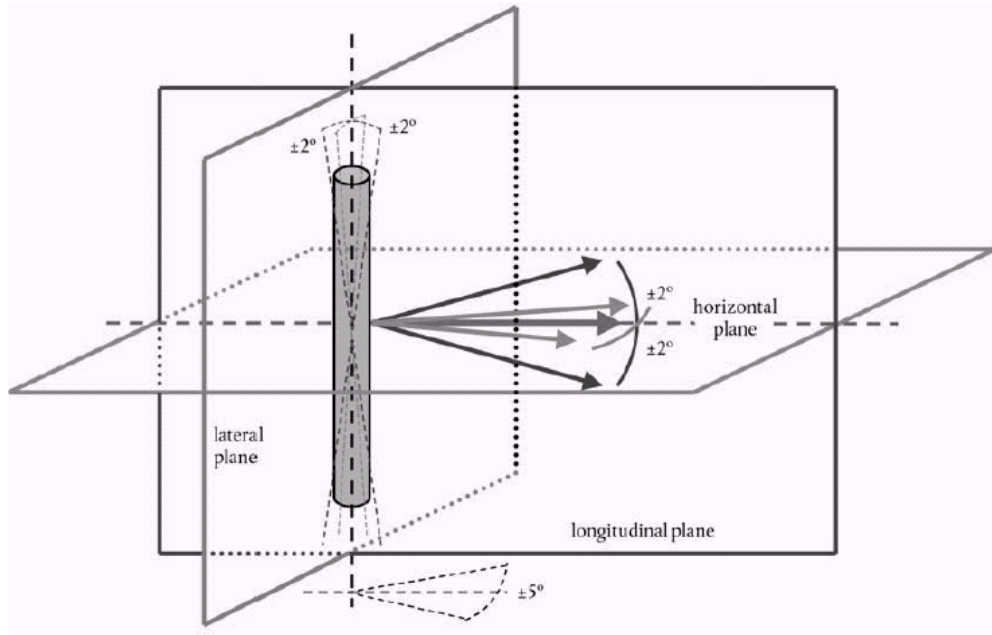

Figure 18: Tolerances of angles for the lower legform impactor at the time of first impact

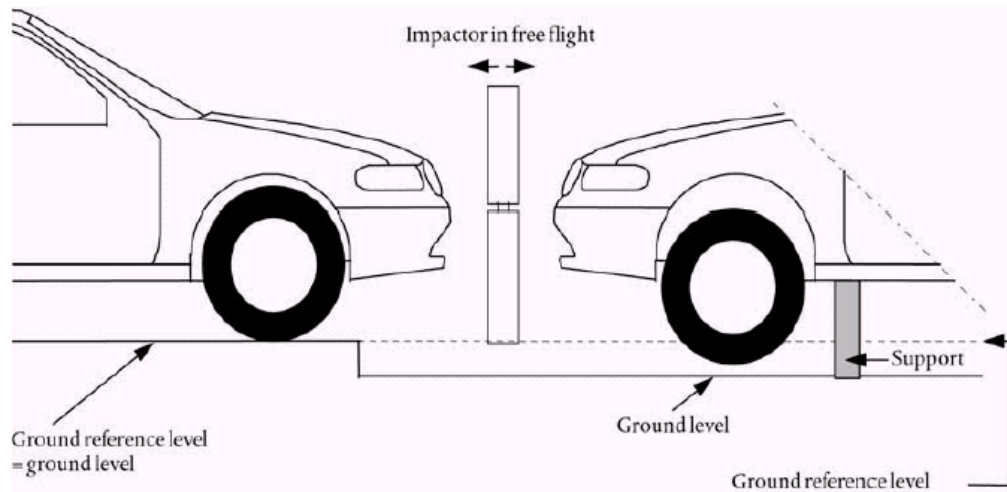

Figure 19: Lower legform to bumper tests for complete vehicle in normal ride attitude (left) and for cut-body mounted on supports (right)

7.1.2 [Upper legform to bumper test procedure:

- 7.1.2.1 If the lower bumper height at the test position is more than 500 mm and the manufacturer elects to perform an upper legform test instead of a lower legform test, a minimum of three lower legform to bumper tests shall be carried out, one each to the middle and the outer thirds of the bumper at positions judged to be the most likely to cause injury. Tests shall be to different types of structure, where they vary throughout the area to be assessed. The selected test points shall be a minimum of 132 mm apart, and a minimum of 66 mm inside the defined corners of the bumper. These minimum distances are to be set with a flexible tape held tautly along the outer surface of the vehicle. The positions tested by the laboratories shall be indicated in the test report.

- 7.1.2.1.1 Manufacturers might apply for derogation concerning an exemption zone for a removable towing hook.
- 7.1.2.2 The direction of impact shall be parallel to the longitudinal axis of the vehicle, with the axis of the upper legform vertical at the time of first contact. The tolerance to this direction is $\pm [2]^\circ$.
- 7.1.2.2.1 At the time of first contact the impactor centre line shall be midway between the upper bumper reference line and the lower bumper reference line with a ± 10 mm tolerance and laterally with the selected impact location with a tolerance of ± 10 mm.
- 7.1.2.3 The impact velocity of the upper legform impactor when striking the bumper shall be $11,1 \pm 0,2$ m/s.]

7.2 Child headform Test Procedure

This test procedure is applicable with respect to the requirements of paragraph 5.2.1 and 5.2.3 of this Regulation.

- 7.2.1 Tests shall be made to the front structure within the boundaries as defined in paragraph 3.11. For tests on the rear area of the bonnet top, the headform impactor shall not contact the windscreen or A-pillar before impacting the bonnet top.

- 7.2.2 [A minimum of [eighteen 18] tests shall be carried out with the child headform impactor, [six 6] tests each to the middle and the outer thirds of the bonnet top, as described in paragraph 3.26 at positions judged to be the most likely to cause injury. Tests shall be to different types of structure, where these vary throughout the area to be assessed.]

OICA comment: This chapter has to be completely reworded along the footnote following 5.2.2 if exemption zones / higher HIC zones have to be introduced.

- 7.2.3 The test points shall be located so that the impactor is not expected to impact the test area with a glancing blow resulting in a more severe second impact. The selected test points **on the bonnet** for the child headform impactor shall, at the time of first contact:
- be a minimum of 165 mm apart,
 - be a minimum of 82.5 mm inside the defined bonnet side reference lines, as defined in paragraph 3.24.
 - be a minimum of 82.5 mm forwards of the rear reference line, as defined in paragraph 3.22.

Each selected test point for the child headform shall also be a minimum of 165 mm rearwards of the bonnet leading edge reference line defined in paragraph 3.6.

If the WAD1700 line is located in the windscreen test area, as defined in paragraph 3.36, at any point, [2] selected test points on the windscreen test area for the child headform impactor shall, at time of first contact:

- be a minimum of 165 mm apart,
- be a minimum of 82.5 mm forwards of the rear windscreen reference line, see paragraph 3.23, or forwards of the WAD1700 line what ever is most forward.

- 7.2.3.1 These minimum distances are to be set with a flexible tape held tautly along the outer surface of the vehicle. If, however, the vehicle configuration does not allow the

number of eighteen impact points to be reached while maintaining the minimum spacing between impact points, then less than eighteen tests may be performed.

- 7.2.3.2 The points selected for testing shall be indicated in the test report.
- 7.2.4 The point of first contact of the headform impactor shall be within a ± 10 mm tolerance to the selected impact location.
- 7.2.5 The headform velocity at the time of impact shall be $[8.9 \pm 0.2 \text{ m/s (32km/h)}]$ [which simulates the vehicle impact speed of 40 km/h, the shape category of the vehicle under test and the location of each selected test point.].

[Note: The method of determining the impact speed is to be reviewed further]

The effect of gravity shall be taken into account when the impact velocity is obtained from measurements taken before the time of first contact.

- 7.2.6 The direction of impact shall be as specified as follows:
- 7.2.6.1 The direction of impact shall be in the longitudinal vertical plane of the vehicle to be tested. The tolerance for this direction is $\pm 2^\circ$. The direction of impact of tests to the front structure shall be downward and rearward.

[7.2.6.2 For vehicles where the bonnet angle, as defined in paragraph 3.3, is not lower than 30° , the angle of impact on the bonnet shall be
 $25^\circ \pm [2]^\circ$ for tests point on the bonnet top defined in 3.8 or
 $[25^\circ \pm [2]^\circ$ for test point in the windscreen test area defined in 3.36]
to the Ground Reference Level.

7.2.6.3 For vehicles where the bonnet angle, as defined in paragraph 3.3, is lower than 30° :

7.2.6.3.1 If the bonnet leading edge height (BLEH), as defined in paragraph 3.5, is not lower than 835 mm, the angle of impact on the bonnet shall be
 $60^\circ \pm [2]^\circ$ for tests point on the bonnet top defined in 3.8 or
 $[40^\circ \pm [2]^\circ$ for test point in the windscreen test area defined in 3.36]
to the Ground Reference Level.

7.2.6.3.2 If the bonnet leading edge height (BLEH), as defined in paragraph 3.5, is lower than 835 mm, the angle of impact on the bonnet shall be
 $65^\circ \pm [2]^\circ$ for tests point on the bonnet top defined in 3.8 or
 $[40^\circ \pm [2]^\circ$ for test point in the windscreen test area defined in 3.36]
to the Ground Reference Level.]

OICA comment: the parameters of impact speed and angle are preliminary agreed during the 6th GTR meeting.

[Note: Sections 7.2.6.2 and 7.2.6.3 may be replaced]

7.2.6.4 The effect of gravity shall be taken into account when the impact angle is obtained from measurements taken before the time of first contact

7.3 Adult headform test procedure

This test procedure is applicable with respect to the requirements of paragraph 5.2.2 and 5.2.3 of the performance requirements of this Regulation.

7.3.1 Tests shall be made to the front structure within the boundaries as defined in paragraph 3.1 above. For tests at the rear of the bonnet top, the headform impactor shall not contact the windscreen or A-pillar before impacting the bonnet top

7.3.2 [A minimum of [eighteen 18] tests shall be carried out with the adult headform impactor, [six 6] tests each to the middle and the outer thirds of the test area, as described in paragraph 3.26, at positions judged to be the most likely to cause injury. Tests shall be to different types of structure, where these vary throughout the area to be assessed.]

OICA comment: This chapter has to be completely reworded along the footnote following 5.2.2 if exemption zones / higher HIC zones have to be introduced.

7.3.3 The test points shall be located so that the impactor is not expected to impact the test area with a glancing blow resulting in a more severe second impact. The selected test points **on the bonnet** for the adult headform impactor shall, at the time of first contact:

- be a minimum of 165 mm apart,
- be a minimum of 82.5 mm inside the defined bonnet side reference lines, as defined in paragraph 3.24.
- be a minimum of 82.5 mm forwards of the **bonnet** rear reference line, as defined in paragraph ~~3.24~~ **3.7** or forwards of the **WAD2100** line what ever is most forward.

If the rear reference line for adult headform (see 3.21) is located ~~in or at the upper border of the windscreen test area, as defined in paragraph 3.36,~~ partly on or forward the rear windscreen reference line, see 3.23, [2] selected tests points in the windscreen test area (see 3.36) for the adult headform impactor shall, at the time of first contact:

- be a minimum of 165 mm apart,
- be a minimum of 82.5 mm forwards the rear reference line for adult headform (see 3.21)
- be a minimum of 82.5 mm rearwards of the lower windscreen reference line (see 3.35) or rearwards of the **WAD1700** line what ever is most rearward.

Each selected test point for the adult headform shall also be a minimum of 165 mm rearwards of the bonnet leading edge reference line defined in paragraph 3.6.

7.3.3.1 These minimum distances are to be set with a flexible tape held tautly along the outer surface of the vehicle. If however the vehicle configuration does not allow the number of eighteen impact points to be reached while maintaining the minimum spacing between impact points, then less than eighteen tests may be performed.

7.3.3.2 The points selected for testing shall be indicated in the test report.

7.3.4 The point of first contact of the headform impactor shall be within a ± 10 mm tolerance to the selected impact location.

7.3.5 The headform velocity at the time of impact shall be $[8.9 \pm 0.2 \text{ m/s (32km/h)}]$ [which simulates the vehicle impact speed of 40 km/h, the shape category of the vehicle under test and the location of each selected test point.].

[Note: The method of determining the impact speed is to be reviewed further]

The effect of gravity shall be taken into account when the impact velocity is obtained from measurements taken before the time of first contact

- 7.3.6 The direction of impact shall be as specified as follows
- 7.3.6.1 The direction of impact shall be in the fore and aft vertical plane of the paragraph of the vehicle to be tested. The tolerance for this direction is $\pm 2^\circ$. The direction of impact of tests to the front structure shall be downward and rearward.
- [7.3.6.2 For vehicles where the bonnet angle, as defined in paragraph 3.3, is not lower than 30° , the angle of impact shall in all case be
 $50^\circ \pm [2]^\circ$ for tests point on the bonnet top defined in 3.8 or
 $[50^\circ \pm [2]^\circ$ for test point in the windscreen test area defined in 3.36]
to the Ground Reference Level.
- 7.3.6.3 For vehicles where the bonnet angle, as defined in paragraph 3.3, is lower than 30° :
- 7.3.6.3.1 If the bonnet leading edge height (BLEH), as defined in paragraph 3.5, is not lower than 835 mm, the angle of impact on the bonnet shall be $90^\circ \pm [2]^\circ$
 $90^\circ \pm [2]^\circ$ for tests point on the bonnet top defined in 3.8 or
 $[40^\circ \pm [2]^\circ$ for test point in the windscreen test area defined in 3.36]
to the Ground Reference Level.
- 7.3.6.3.2 If the bonnet leading edge height (BLEH), as defined in paragraph 3.5, is lower than 835 mm, the angle of impact on the bonnet shall be
 $65^\circ \pm [2]^\circ$ for tests point on the bonnet top defined in 3.8 or
 $[40^\circ \pm [2]^\circ$ for test point in the windscreen test area defined in 3.36]
to the Ground Reference Level.]
OICA comment: the parameters of impact speed and angle are preliminary agreed during the 6th GTR meeting.
- [**Note:** **Sections 7.3.6.2 and 7.3.6.3 may be replaced**]
- 7.3.6.4 The effect of gravity shall be taken into account when the impact angle is obtained from measurements taken before the time of first contact

8. Certification of Impactors.

[**Note:** **Section to be developed and added.**]