

Informal document No. **GRRF-56-6**
(56th GRRF, 20-22 September 2004,
agenda item 3.)

ECONOMIC COMMISSION FOR EUROPE

INLAND TRANSPORT COMMITTEE

World Forum for Harmonization of Vehicle Regulations (WP.29)

Working Party on Brakes and Running Gear (GRRF)
(Fifty-sixth session, 20-22 September 2004,
agenda item.3.)

PROPOSAL FOR DRAFT AMENDMENTS TO REGULATION No. 90
(Braking)

Transmitted by the expert from Germany

Note: The text reproduced below was prepared by the experts from Germany to add to ECE-Regulation No. 90 special requirements for replacement brake discs and drums sold by the aftermarket.

Note: This document is distributed to the Experts on Brakes and Running Gear only.

A. JUSTIFICATION

The requirements for the braking systems of motor vehicles have been increased in the last years.

One of the reasons for this is the increased power output of the motor vehicle engines. During braking this increased engine performance must be converted by friction into heat.

At the same time, the behaviour of vehicle owners has changed considerably, buying replacement parts to replace worn out original equipment (OE) parts and components more and more no longer from authorised dealers of the vehicle manufacturers but instead of that from free aftermarket dealers and workshops.

In addition, the installed braking performance of modern motor vehicles has also been substantially increased in combination with lightweight construction of the braking components with the result of extreme stress demand on the material.

In order that the replacement brake discs and drums sold by the aftermarket guarantee a comparable standard to the original parts of the vehicle manufacturers it is proposed to define minimum requirements for these safety components.

Germany sees the possibility to add a special annex (or annexes) to ECE-Regulation No. 90 for these safety parts.

ECE-R90 specifies: “Uniform provisions concerning the approval of replacement brake lining assemblies and drum brake linings for power-driven vehicles and their trailers”.

Until now there are no requirements for the above mentioned safety parts.

Therefore, Germany proposes to add new requirements for aftermarket replacement brake discs and drums to ECE-R90.

The following German proposal is seen as a discussion paper for deliberations within GRRF to install an ad hoc Working Group to deal with this subject.

The intent of this proposal is to define requirements for replacement discs and drums which are neither original parts (OE or OES part) nor fall under the definition of Article 1t of the Block Exemption Regulation No. 1400/2002 of 31st July 2002.

Under “OE or OES” part it is understood the original equipment part fitted to the vehicle at the time of production or the part sold by the vehicle manufacturer as an original spare part.

This proposal is based on national technical requirements which are applied by German Technical Services when a replacement manufacturer asks for an assessment for his component.

Germany is aware that some proposed requirements have to be re-discussed under the light of introducing these requirements into ECE-Regulation No. 90.

In particular to the following points:

- Test group definition (replacement components are used for various applications - e.g. various vehicle manufacturer producing vehicles with a great difference in brake performances)
- The current German proposal does not address COP requirements. This topic should be dealt with in GRRF or an ad hoc Group. The same applies to other issues like the kind of the approval number, etc.
- Germany assumes also that a special ad hoc group will address the problem of special brake discs and drums designs which do differ significantly from the original part with respect to the material and dimensions.

B. PROPOSAL

Heading, amend to read:

UNIFORM PROVISIONS CONCERNING THE APPROVAL OF REPLACEMENT BRAKE LINING ASSEMBLIES, ~~AND~~ DRUM BRAKE LININGS, ~~DISCS AND DRUMS~~ FOR POWER-DRIVEN VEHICLES AND THEIR TRAILERS

ANNEXES

In Section "CONTENT" add the headings of the following new annexes:

- Annex 1A - Communication concerning the approval or extension or refusal or withdrawal of approval or production definitely discontinued of a replacement brake lining assembly or replacement drum brake lining pursuant to Regulation No. 90
- Annex 1B - Communication concerning the approval or extension or refusal or withdrawal of approval or production definitely discontinued of a replacement brake drum or replacement brake disc pursuant to Regulation No. 90
- Annex 9 - Illustrations
- Annex 10 - Requirements for replacement brake discs/drums for vehicles of category M and N
- Annex 11 - Requirements for replacement brake discs/drums for vehicles of category O
- Annex 12 - Requirements for replacement brake discs/drums for vehicles of category L

Paragraph 1.1, amend to read:

- 1.1. This Regulation applies to replacement service brake lining assemblies and brake drums and discs intended for use in friction brakes forming part of the braking system of power-driven vehicles and their trailers authorized for use on public roads.
- 1.2. Replacement brake lining assemblies and brake drums and discs may be approved for fitment and use on power-driven vehicles and trailers having type approval in accordance with Regulation No. 13 or Regulation No. 78.
Replacement drum brake linings ...

2. DEFINITIONS

For the purposes of this Regulation;

Insert a new paragraph 2.1 (new heading), to read:

2.1. General definitions

Paragraph 2.12 (former), renumber as paragraph 2.1.1.

- 2.1.1. "Manufacturer" means the organization which can assume technical responsibility for the brake lining assemblies or drum brake linings or brake drums and discs and can demonstrate that it possesses the necessary means to achieve conformity of production.

Insert a new paragraph 2.1.2, to read:

- 2.1.2. "Replacement part": means - for the sake of simplicity - either a replacement brake lining assembly type, a replacement drum brake lining type, a drum brake lining, a replacement brake drum or a replacement brake disc.

Insert a new paragraph 2.2 (new heading), to read:

- 2.2. Definitions regarding the approval of a replacement brake lining assembly type, a replacement drum brake lining type or a drum brake lining.

Paragraphs 2.1 to 2.11 (former), renumber as paragraphs 2.2.1 to 2.2.11.

- 2.2.1. "Braking system" has the meaning assigned in Regulation No. 13, paragraph 2.3.;
- 2.2.2. "Friction brake" means the part of a braking system in which the forces opposing the movement of a vehicle are developed by friction between a brake lining and a wheel disc or drum moving relatively to each other;
- 2.2.3. "Brake lining assembly" means a component of a friction brake which is pressed against a drum or disc, respectively, to produce the friction force;
- 2.2.3.1. "Shoe assembly" means a brake lining assembly of a drum brake;
- 2.2.3.1.1. "Shoe" means a component of a shoe assembly which carries the brake lining;
- 2.2.3.2. "Pad assembly" means a brake lining assembly of a disc brake;
- 2.2.3.2.1. "Backplate" means a component of a pad assembly which carries the brake lining;
- 2.2.3.3. "Brake lining" means the friction material component with the shape and final dimension to be fixed on to the shoe or backplate;
- 2.2.3.4. "Drum brake lining" means a brake lining for a drum brake.
- 2.2.3.5. "Friction material" means the product of a specified mixture of materials and processes which together determine the characteristics of a brake lining;

- 2.2.4. "Brake lining type" means a category of brake linings which do not differ in friction material characteristics;
- 2.2.5. "Brake lining assembly type" means wheel sets of brake lining assemblies which do not differ in brake lining type, dimension or functional characteristics;
- 2.2.6. "Drum brake lining type" means wheel sets of brake lining components which after fitment to the shoes do not differ in brake lining type, dimensions or functional characteristics.
- 2.2.7. "Original brake lining" means a brake lining type referenced in the vehicle type approval documentation, Regulation No. 13, annex 2, paragraph 8.1.¹ or Regulation No. 78, annex 1, paragraph 5.4.;
- 2.2.8. "Original brake lining assembly" means a brake lining assembly conforming to the data attached to a vehicle type approval documentation;
- 2.2.9. "Replacement brake lining assembly" means a brake lining assembly of a type approved under this Regulation as a suitable service replacement for an original brake lining assembly;
- 2.2.10. "Original drum brake lining" means a drum brake lining conforming to the data attached to a vehicle type approval documentation.
- 2.2.11. "Replacement drum brake lining" means a drum brake lining of a type approved under this Regulation as a suitable service replacement when fitted to a shoe for an original drum brake lining.

Insert the new paragraphs 2.3 to 2.3.15, to read:

- 2.3. Definitions regarding the approval of a replacement brake drum or a replacement brake disc.
- 2.3.1 "Original brake disc" (original parts, original replacement parts): a brake disc which forms part of the vehicle's original equipment and which is covered by the vehicle's type approval.
- 2.3.2 "Original brake drum" (original parts, original replacement parts): a brake drum which forms part of the vehicle's original equipment and which is covered by the vehicle's type approval.
- 2.3.3. "Identical brake disc" or "identical brake drum": vehicle parts for which the manufacturer applies the same production and quality assurance systems as for the original parts pursuant to 2.3.1. and 2.3.2. which it supplies as part of the original equipment. Furthermore, the identical part corresponds, with the

¹/ If such brake linings are not available on the market, alternatively, brake linings listed under paragraph 8.2. may be used.

exception of the vehicle manufacturer's mark, which is absent, to the vehicle's original part, it is provided with a durably legible mark from the part manufacturer and is manufactured under the same technical and qualitative preconditions as the original part.

The part manufacturer's quality assurance system shall especially ensure that the specifications in relation to the original part and its production are fully available and up-to-date for each identical brake disc or drum and that, by means of suitable measures, compliance with all the requirements stipulated therein, with the exception of the abovementioned marking, is guaranteed for each part manufactured.

- 2.3.4. "Replacement brake disc": in the context of this regulation, this is a brake disc that is not classified as an original brake disc pursuant to 2.3.1., as an identical brake disc as per 2.3.3.
- 2.3.5. "Replacement brake drum": in the context of this regulation, this is a brake drum that is not classified as an original brake drum pursuant to 2.3.2, as an identical brake drum as per 2.3.5.
- 2.3.6. "Functional dimensions": all the measurements that are relevant with regard to the fitting and functioning of the components of the braking system (cf. 5.3.3.1. and Annex 9).
- 2.3.7. "Tolerances": these are dimensional tolerances in accordance with ISO 286-1 and shape and positional tolerances according to ISO 1101.
- 2.3.8. "Shielding": this is a deflection of the outside diameter of the disc from the plane of the inside diameter.
- 2.3.9. "Type of brake disc and drum": combination of brake discs/drums having the same basic structure and material group in accordance with the classification criteria pursuant to 5.3.1.
- 2.3.10. "Test group": combination of one type of brake discs/drums having the same characteristics pursuant to 5.3.2.
- 2.3.11. "Variant": individual brake disc/drum possessing a part number from the manufacturer.
- 2.3.12. "Material": chemical analysis and physical properties as per 3.4.1.2.
- 2.3.13. "Material group": (e.g. grey cast iron, steel, aluminium, etc.)

Paragraphs 3.1 to 3.6.1, amend to read:

- 3.1. An application for approval of a replacement part for (a) specific vehicle type(s) shall be submitted by the manufacturer of the replacement part or his duly accredited representative.

- 3.2. An application may be submitted by the holder of (a) vehicle type approval(s) to Regulation No. 13 or Regulation No. 78 in respect of replacement part conforming to the type recorded in the vehicle type approval(s) documentation.

Insert a new paragraph 3.3, to read:

- 3.3. In the case of an application regarding the approval of a replacement brake lining assembly type, a replacement drum brake lining type or a drum brake lining:

Paragraphs 3.3 to 3.6.1 (former), renumber as paragraphs 3.3.1 to 3.3.3.4.1 as follows:

- 3.3.1. An application for approval shall be accompanied, in triplicate, by a description of the replacement brake lining assembly or replacement drum brake lining with regard to the items specified in annex 1A to this Regulation, and by the following particulars:
- 3.3.1.1. diagrams showing functional dimensions of the replacement brake lining assembly or replacement drum brake lining;
- 3.3.1.2. an indication of the positions of the replacement brake lining assembly or replacement drum brake lining on the vehicles for which approval to fit is sought.
- 3.3.2. Brake lining assemblies or drum brake linings of the type for which approval is sought shall be made available in sufficient quantity to perform the approval tests.
- 3.3.3. The applicant shall agree with and make available to the technical service responsible for conducting approval tests the suitable representative vehicle(s) and/or brake(s).
- 3.3.4. The competent authority shall verify the existence of satisfactory arrangements for ensuring effective control of the conformity of production before type approval is granted.
- 3.3.4.1 The applicant shall submit values for friction behaviour in accordance with annex 8 A, paragraph 2.4.1. or 3.4.1. respectively of this Regulation.

Insert the new paragraphs 3.4 to 3.4.2.1, to read:

- 3.4. In the case of an application regarding the approval of a replacement brake drum or a replacement brake disc.
- 3.4.1. An application for approval shall be accompanied, in triplicate, by a description of replacement brake drum or a replacement brake disc with regard to the items specified in annex 1B to this Regulation, and by the following particulars:

3.4.1.1 Drawing including all the accessories

- Location and nature of the marking pursuant to 5.3, - dimensions in mm,
- weight in grams,
- material.

3.4.1.2 Component description

The manufacturer shall compile all the important data pertaining to the manufacture of the part(s) in a description.

- The manufacturer of the unmachined part,
- a description of the process of manufacture of the unmachined part,
- proof of the reliability of the process (e.g. freedom from cracks and cavities, dimensions),
- mechanical processing,
- material composition using chemical analysis and according to its mechanical properties (test certificate pursuant to DIN 50049),
- corrosion or surface protection, description of the balancing measures, maximum permissible balance error,
- degree of wear and tear (minimum thickness) in the case of brake discs or the maximum inside diameter in the case of brake drums,
- as regards category L vehicles, the maximum permissible tolerance in the disc thickness across the circumference.

3.4.1.3 Fitting instruction

3.4.1.3.1 The manufacturer shall specify in a fitting instruction (specimen) all the important data relating to the installation of the component, including - directions on the starting torque of the threaded joints in Nm and - instructions concerning the degreasing/dewaxing of the brake disc/drums.

3.4.2. The competent authority shall verify the existence of satisfactory arrangements for ensuring effective control of the conformity of production before type approval is granted.

3.4.2.1 The applicant shall submit ??? in accordance with annex 8 B , paragraph 2.4.1. or 3.4.1. respectively of this Regulation.

Note: The issue of conformity of production has to be discussed in an international ad hoc group at a later time.

4. APPROVAL

- 4.1. If the replacement part submitted for approval pursuant to this Regulation meet the requirements of paragraph 5. below, approval of the replacement part shall be granted.
- 4.1.1. In the case of replacement brake lining assemblies for vehicles of category L with a combined braking system in the meaning of paragraph 2.9. of Regulation No. 78, the approval must be restricted to the brake lining assembly combination(s) on the axles of the vehicle having been tested according to annex 7 of this Regulation.

Paragraphs 4.2 to 4.5, amend to read:

- 4.2. To each replacement part approved there shall be assigned an approval number comprising three groups of digits:
- 4.2.1. The first two digits (at present 01 for the Regulation in its 01 series of amendments) shall indicate the series of amendments incorporating the most recent major technical amendments made to the Regulation at the time of issue of the approval.
- 4.2.2. The following three digits shall indicate the type of the brake lining, the disc or the drum. ... **???** *has to be defined later*
- 4.2.3. A suffix of three digits shall indicate
- the shoe or back plate or specific dimension in the case of drum brake linings,
 - ... **???*** in the case of a replacement disc
 - ... **???*** in the case of replacement drum

*** has to be defined later**

- 4.3. The same Contracting Party may not assign the same number to another replacement part. The same type approval number may cover the use of that replacement part on a number of differing vehicle types.
- 4.4. Notice of approval or of extension or refusal of approval or withdrawal of approval or production definitely discontinued of a replacement part pursuant to this Regulation shall be communicated to the Parties to the 1958 Agreement which apply this Regulation by means of a form conforming to the model in annex 1 to this Regulation.

- 4.5. There shall be affixed, conspicuously and in a readily accessible place, to every replacement part approved under this Regulation, an international approval mark consisting of:

Paragraphs 4.7, amend to read:

- *** 4.7. Annex 2 to this Regulation gives examples of arrangements of the approval mark and approval data referred to above and in paragraph 6.5. below.

* has to be defined later

5. SPECIFICATIONS AND TESTS

Paragraph 5.1 and its subparagraphs, amend to read:

5.1. General

A replacement part shall be so designed and constructed that, when substituted for the part originally fitted to a vehicle, the braking efficiency of that vehicle accords with that of the approved vehicle type.

Specifically:

- (a) a vehicle equipped with replacement part shall satisfy the relevant braking prescriptions of Regulation No. 13 including the 09 series of amendments or Regulation No. 78 including the 01 series of amendments;
- (b) a replacement part shall display performance characteristics similar to that of the original part it is intended to replace;
- (c) a replacement part must possess adequate mechanical characteristics;
- (d) brake linings shall not contain asbestos;
- (e) a replacement brake disc/drum shall exhibit sufficient deformation resistance under temperature.

- 5.1.1. Replacement brake lining assemblies or replacement drum brake linings conforming to the type specified in vehicle type approval documentation to Regulation No. 13 or Regulation No. 78 and brake discs/drums which are manufactured according to the specifications and production standards provided by the vehicle manufacturer for the production of these components for the vehicle in question are deemed to satisfy the requirements of paragraph 5. of this Regulation.

Insert a new paragraph 5.2, to read:

5.2. Requirements regarding the approval of a replacement brake lining assembly type, a replacement drum brake lining type or a drum brake lining:

Paragraphs 5.2 to 5.3.2.3 (former), renumber as paragraphs 5.2.1 to 5.2.2.3. as follows:

5.2.1. Performance requirements

5.2.1.1. Replacement brake lining assemblies for vehicles of categories M1, M2 and N1

Replacement brake lining assemblies shall be tested according to the prescriptions of annex 3 and must satisfy the requirements stated in this annex. For speed sensitivity and cold performance equivalence one of the two methods described in annex 3 shall be used.

5.2.1.2. Replacement brake lining assemblies and replacement drum brake linings for vehicles of categories M3, N2 and N3

Replacement brake lining assemblies and replacement drum brake linings shall be tested according to the prescriptions of annex 4, using one of the two methods described in paragraph 1 (vehicle test) or in paragraph 2 (inertia dynamometer test) and shall satisfy the requirements stated in this annex.

5.2.1.3. Replacement brake lining assemblies for vehicles of categories O1 and O2

Replacement brake lining assemblies shall be tested according to the prescriptions of annex 5 and shall satisfy the requirements stated in this annex.

5.2.1.4. Replacement brake lining assemblies and replacement drum brake linings for vehicles of categories O3 and O4

Replacement brake lining assemblies and replacement drum brake linings shall be tested according to the prescriptions of annex 6 and shall satisfy the requirements stated in this annex. For the tests one of the three methods described in paragraph 3 of appendix 2 to annex 11 of Regulation No. 13 shall be used.

5.2.1.5. Replacement brake lining assemblies for vehicles of category L

Replacement brake lining assemblies shall be tested according to the prescriptions of annex 7 and shall satisfy the requirements stated in this annex.

5.2.2. Mechanical characteristics

5.2.2.1. Replacement brake lining assemblies for vehicles of categories M1, M2, N1, O1, O2, and L

5.2.2.1.1. Replacement brake lining assemblies of the type for which approval is requested shall be tested for shear strength according to Standard ISO 6312:1981.

The minimum acceptable shear strength is 250 N/cm² for pad assemblies and 100 N/cm² for shoe assemblies.

5.2.2.1.2. Replacement brake lining assemblies of the type for which approval is requested shall be tested for compressibility according to Standard ISO 6310:1981.

The compressibility values shall not exceed 2 per cent at ambient temperature and 5 per cent at 400 EC for pad assemblies and 2 per cent at ambient temperature and 4 per cent at 200 EC for shoe assemblies.

5.2.2.2. Replacement brake lining assemblies and replacement drum brake linings for vehicles of categories M3, N2, N3, O3, and O4

5.2.2.2.1. Shear strength

This test applies only to disc brake pad assemblies.

Replacement brake lining assemblies of the type for which approval is requested shall be tested for shear strength according to Standard ISO 6312:1981. Brake lining assemblies may be divided into two or three parts to match the test machine's capability.

The minimum acceptable shear strength is 250 N/cm².

5.2.2.2.2. Compressibility

Replacement brake lining assemblies and replacement drum brake linings of the type for which approval is requested shall be tested for compressibility according to Standard ISO 6310:1981. Flat specimens according to sample type I may be used.

The compressibility values shall not exceed 2 per cent at ambient temperature and 5 per cent at 400 EC for pad assemblies and 2 per cent at ambient temperature and 4 per cent at 200 EC for shoe assemblies and drum brake linings.

5.2.2.2.3. Material hardness

This requirement applies to drum brake lining assemblies and drum brake linings.

Replacement brake lining assemblies or replacement drum brake linings of the type for which approval is requested shall be tested for hardness according to Standard ISO 2039-2:1987.

The hardness figure for the friction material at the rubbing surface shall be the mean value out of five sample linings from different production batches (if available) by taking five measurements at different places of each brake lining.

Insert the new paragraphs 5.3 to 5.3.3.3, to read:

5.3. Requirements regarding the approval of a replacement brake drum or a replacement brake disc:

5.3.1. Type classification criteria

Brake discs/drums that do not differ in terms of their main characteristics below shall be regarded as one type within one report or approval:

- 5.3.1.1 Type classification criteria for brake discs
- Type of cooling (ventilated/non-ventilated)
 - Hat (with (with or without integrated parking brake drum)/without)
 - Hub (with/without)
 - Material group
 - Bond (rigid, semi-floating, floating, etc.)
- 5.3.1.2 Type classification criteria for brake drums
- Material group
 - Ground finish (e.g. steel, cast iron)
- 5.3.2. Classification criteria for test groups within the same type
- From each of the test groups mentioned below, at least one variant is subject to the corresponding tests laid down in Annexes 10, 11 or 12.
- Determining the test groups and the choice of part to be tested each time is laid down by the expert in agreement with the applicant.
- 5.3.2.1 Replacement brake discs
- 5.3.2.1.1 Criteria concerning the formation of test groups with regard to replacement brake discs in vehicles belonging to categories M1, M2, N1, N2, O1 and O2
- 5.3.2.1.1.1 Test group relating to the tests stipulated in Sections 1 to 5 of Annex 10 or Annex 11
- This test group includes all brake discs where the outside diameter of the disc do not vary by more than 6 mm and and the disc thickness by not more than 4 mm.
- 5.3.2.1.1.2 In the case of different materials within a group of materials, proof shall be furnished for each separate material that the requirements stipulated in Annex 10 or Annex 11 are met.
- 5.3.2.1.2 Criteria concerning the formation of test groups with regard to replacement brake discs in vehicles belonging to categories M3, N3, O3 and O4
- 5.3.2.1.2.1 Test group relating to the tests stipulated in Sections 1 to 5 of Annex 10 or Annex 11
- This test group includes all brake discs where the outside diameter of the disc do not vary by more than 10 mm and and the disc thickness by not more than 4 mm.
- 5.3.2.1.2.2 In the case of different materials within a group of materials, proof shall be furnished for each separate material that the requirements stipulated in Annex 10 or Annex 11 are met.

- 5.3.2.1.3 Criteria concerning the formation of test groups with regard to replacement brake discs in category L vehicles
 - 5.3.2.1.3.1 Test group relating to the tests stipulated in Sections 1 to 5 of Annex 12
This test group includes all brake discs where the outside diameter of the disc do not vary by more than ± 20 mm and the disc thickness by not more than ± 0.5 mm.
 - 5.3.2.1.3.2 In the case of different materials within a group of materials, proof shall be furnished for each separate material that the requirements stipulated in Annex 12 are met.

- 5.3.2.2 Replacement brake drums
 - 5.3.2.2.1 Criteria concerning the formation of test groups with regard to replacement brake drums in vehicles belonging to categories M1, M2, N1, N2, O1 and O2
 - 5.3.2.2.1.1 Test group relating to the tests stipulated in sections 1 to 5 of Annex 10 or Annex 11
This test group includes all brake drums that do not vary by more than 30 mm in terms of the inside diameter of the drum and by more than 10 mm as regards the shoe width of the drum brake.
 - 5.3.2.2.1.2 In the case of different materials within a group of materials, proof shall be furnished for each separate material that the requirements stipulated in Annex 10 or Annex 11 are met.
 - 5.3.2.2.2 Criteria concerning the formation of test groups with regard to replacement brake drums in vehicles belonging to categories M3, N3, O3 and O4
 - 5.3.2.2.2.1 Test group relating to the tests stipulated in Sections 1 to 5 of Annex 10 or Annex 11
This test group includes all brake drums that do not vary by more than 10% (referring to the smallest value) in terms of the inside diameter of the drum and by more than 40 mm as regards the shoe width of the drum brake.
 - 5.3.2.2.2.2 In the case of different materials within a group of materials, proof shall be furnished for each separate material that the requirements stipulated in Annex 10 or Annex 11 are met.
 - 5.3.2.2.3 Criteria concerning the formation of test groups with regard to replacement brake drums in category L vehicles
 - 5.3.2.2.3.1 Test group relating to the tests stipulated in Sections 1 to 5 of Annex 12
This test group includes all brake drums that do not vary by more than 10 mm (categories L1 to L4) or 20 mm (category L5) in terms of the inside diameter of the drum, and by more than 5 mm (categories L1 to L4) or 10 mm (category L5) as regards the shoe width of the drum brake.

5.3.2.2.3.2 In the case of different materials within a group of materials, proof shall be furnished for each separate material that the requirements stipulated in Annex 12 are met.

5.3.3. Scope of testing with regard to replacement brake discs/drums

5.3.3.1. Geometric tests

Compared with original parts, replacement brake discs/drums shall be tested in terms of the following characteristics (cf. also Annex 9):

- Disc/drum diameter (in the case of parking brake drums, the inside diameter of the drum as well),
- disc thickness (original dimensions and the level of wear and tear), - top hat depth and wall thickness,
- screwed flange (diameter and thickness at bore),
- pitch circle diameter,
- number of boreholes for fixing,
- flange diameter,
- thickness of bearing surface,
- type of centring,
- as regards parking brake drums, also the width of the surface contact area, - the heat compensation groove,
- in the case of ventilated brake discs
 - the type of ventilation (internal/external)
 - the number of ribs and
 - the dimensions of the cooling ductshall also be tested.

5.3.3.2. Balancing provision

The balancing provision with regard to the replacement brake discs/drums shall correspond to that of the original part being replaced.

5.3.3.3. Further tests

Each test group within a particular type of replacement brake disc/drum shall be tested (see 5.3.2.).

6. PACKAGING AND MARKING

Insert a new paragraph 6.1, to read:

- 6.1. Packaging and marking requirements regarding a replacement brake lining assembly type, a replacement drum brake lining type or a drum brake lining:

Paragraphs 6.1 to 6.5.3 (former), renumber as paragraphs 6.1.1 to 6.1.5.3. as follows:

- 6.1.1. Replacement brake lining assemblies or replacement drum brake linings conforming to a type approved in accordance with this Regulation shall be marketed in axle sets.
- 6.1.2. Each axle set shall be contained in a sealed package constructed to show previous opening.
- 6.1.2.1. In the case of replacement drum brake linings rivets of suitable size and material shall be provided together with the brake linings.
- 6.1.3. Each package shall display the following information:
- 6.1.3.1. the quantity of replacement brake lining assemblies or replacement drum brake linings in the package;
- 6.1.3.2. manufacturer's name or trade mark;
- 6.1.3.3. make and type of replacement brake lining assemblies or replacement drum brake linings;
- 6.1.3.4. the vehicles/axles/brakes for which the contents are approved;
- 6.1.3.5. the approval mark.
- 6.1.4. Each package shall contain fitting instructions in an official ECE language, supplemented by the corresponding text in the language of the country where it is sold:
- 6.1.4.1. with particular reference to auxiliary parts;
- 6.1.4.2. stating that replacement brake lining assemblies or replacement drum brake linings should be replaced in axle sets;
- 6.1.4.3. with, in the case of replacement drum brake linings, a general statement calling attention to the following points:
the integrity of the shoe platform, abutment and pivot;
freedom of the shoe from distortion, deformation and corrosion;
the type and size of rivet to be used;
the required riveting tools and forces.
- 6.1.4.4. with, additionally, in the case of combined braking systems in the meaning of paragraph 2.9. of Regulation No. 78 giving the approved brake lining assembly combination(s).
- 6.1.5. Each replacement brake lining assembly or replacement drum brake lining shall display permanently one set of approval data:

- 6.1.5.1. the approval mark;
- 6.1.5.2. the date of manufacture, at least month and year;
- 6.1.5.3. make and type of brake lining.

Insert new paragraph 6.2 to 6.2.1, to read:

- 6.2. Packaging and marking requirements regarding an identical brake disc or identical brake drum and a replacement brake drum or a replacement brake disc:
 - 6.2.1. Every unit sold shall at least exhibit the following information:
 - 6.2.1.1. part number,
 - 6.2.1.2. make, type and trade name of the vehicle, the axle intended to be fitted, period of manufacturing of the vehicle¹⁾
 - 6.2.1.3. that the fitting of brake discs/drums may only be effected on an axle in pairs,
 - 6.2.1.4. fitting instructions, giving particular consideration, if necessary, to any accessories
 - 6.2.2. Marking
 - Every brake disc/drum approved in accordance with this regulation shall be durably marked, carrying at least the following information:
 - 6.2.2.1 The manufacturer or registered trademark,
 - 6.2.2.2 the brake disc/drum type, variant and approval number
 - 6.2.2.3 an indication of the casting batch,
 - 6.2.2.4 the minimum thickness of the brake disc or the maximum permissible inside diameter of the brake drum.

Paragraphs 7 to 7.1.1, amend to read:

- 7. **MODIFICATIONS AND EXTENSION OF APPROVAL OF REPLACEMENT PARTS**
- 7.1. Every modification of the replacement part shall be notified to the administrative department which granted the type approval. The department may then either:

¹⁾ A reference to the comparable original equipment product number specifying the maximum test load is also deemed sufficient.

- 7.1.1. consider that the modifications made are unlikely to have appreciable adverse effects and that in any event the replacement part still complies with the requirements; or

8. CONFORMITY OF PRODUCTION

Insert a new paragraph 8.1, to read:

- 8.1. Conformity of production requirements regarding a replacement brake lining assembly type, a replacement drum brake lining type or a drum brake lining:

Paragraphs 8.1 to 8.5.5 (former), renumber as paragraphs 8.1.1 to 8.1.5.5. as follows:

- 8.1.1. Replacement brake lining assemblies or replacement drum brake linings approved to this Regulation shall be so manufactured as to conform to the type approved.
- 8.1.2. Original brake lining assemblies or original drum brake linings being the subject of an application under paragraph 3.2. are deemed to satisfy the requirements of paragraph 8.1.
- 8.1.3. To verify that the requirements of paragraph 8.1.1. are met, suitable controls of the production shall be applied. These shall encompass the control of raw materials and components used.
- 8.1.4. The holder of an approval shall in particular:
- 8.1.4.1. ensure that for each replacement brake lining assembly type or replacement drum brake lining type at least the relevant tests prescribed in paragraph 5.3. and a friction behaviour test as prescribed in annex 8 to this Regulation are carried out on a statistically controlled and random basis in accordance with a regular quality assurance procedure;
- 8.1.4.2. ensure existence of procedures for the effective control of the quality of products;
- 8.1.4.3. have access to the control equipment necessary for checking the conformity of each approved type;
- 8.1.4.4. analyze the results of each type of test in order to verify and ensure the consistency of the product characteristics, making allowance for variation of an industrial production;
- 8.1.4.5. ensure that data of test results are recorded and that annexed documents remain available for a period to be determined in agreement with the administrative service;
- 8.1.4.6. ensure that any samples or test pieces giving evidence of non-conformity with the type of test considered shall give rise to another sampling and another test. All the necessary steps shall be taken to re-establish the conformity of the corresponding production.
- 8.1.5. The competent authority which has granted type-approval may at any time verify the conformity control methods applicable to each production unit.

- 8.1.5.1. In every inspection, the test books and production survey records shall be presented to the visiting inspector.
- 8.1.5.2. The inspector may take samples at random to be tested in the manufacturer's laboratory. The minimum number of samples may be determined according to the results of the manufacturer's own verification.
- 8.1.5.3. When the quality level appears unsatisfactory or when it seems necessary to verify the validity of the tests carried out in application of paragraph 8.1.5.2. the inspector shall select samples to be sent to the technical service which has conducted the type approval tests.
- 8.1.5.4. The competent authority may carry out any tests prescribed in this Regulation.
- 8.1.5.5. The normal frequency of inspections authorized by the competent authority shall be one per year. In the case where negative results are recorded during one of these visits, the competent authority shall ensure that all necessary steps are taken to re-establish the conformity of production as rapidly as possible.

Insert a new paragraph 8.2, to read:

- 8.2. Conformity of production requirements regarding a replacement brake drum or a replacement brake disc:
 - 8.2.1. Replacement brake drums or replacement brake discs approved to this Regulation shall be so manufactured as to conform to the type approved.
 - 8.2.2. ??? ...

* The necessity of COP has to be discussed in the GRRF

9. PENALTIES FOR NON-CONFORMITY OF PRODUCTION

Paragraph 9.1, amend to read:

- 9.1. The approval granted in respect of a replacement brake lining assembly type or drum brake lining type pursuant to this Regulation may be withdrawn if the requirements laid down in paragraph 8.1.1. above are not complied with.

The approval granted in respect of the type of a replacement brake drum or a replacement brake disc pursuant to this Regulation may be withdrawn if the requirements laid down in paragraph 8.2.1. above are not complied with.

Paragraph 10, amend to read:

10. PRODUCTION DEFINITELY DISCONTINUED

If the holder of the approval completely ceases to manufacture a replacement part approved in accordance with this Regulation, he shall so inform the authority which granted the approval. Upon receiving the relevant communication that

authority shall inform thereof the other Parties to the 1958 Agreement applying this Regulation by means of a communication form conforming to the model in annex 1A or 1B to this Regulation.

ANNEXES 1A and 1B

Heading of Annex 1 (former) renumber as Annex 1A, amend to read:

Annex 1A

Insert a new Annex 1B, to read:

Annex 1B

COMMUNICATION

(maximum format: A4 (210 x 297 mm))

issued by: Name of administration:

.....
.....
.....

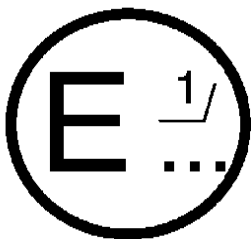

concerning: 2/ APPROVAL GRANTED
 PPROVAL EXTENDED
 PPROVAL REFUSED
 PPROVAL WITHDRAWN
 RODUCTION DEFINITELY DISCONTINUED

of a replacement brake drum or a replacement brake disc pursuant to Regulation No. 90

Approval No.

Extension No.

- 1. Applicant's name and address
- 2. Manufacturer's name and address
- 3. Make and type of brake discs/drum

* has to be defined later

ANNEX 2

ARRANGEMENTS OF THE APPROVAL MARK AND APPROVAL DATA

Paragraph reference, amend to read:

(See paragraph 4.8. of this Regulation)

Add a new note, to read:

Example 1 of an approval mark

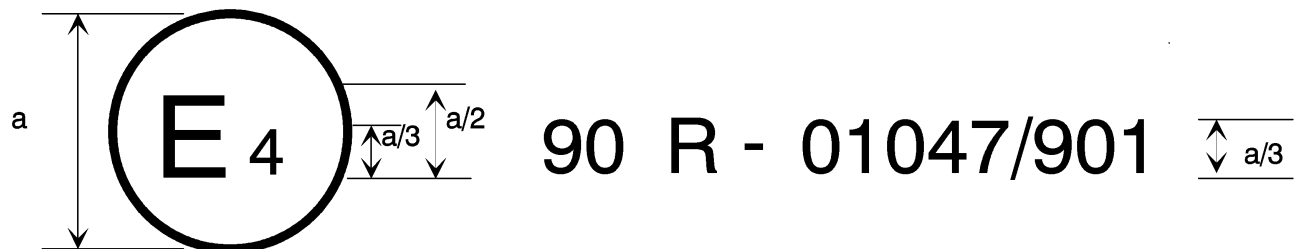

??? Add a new example 2 of an approval mark, to read:

(See paragraph **???** of this Regulation)

??? Example 2 of an approval mark

* has to be defined later

ANNEXES 8A and 8B

Heading, amend to read:

Annex 8 A

DETERMINATION OF FRICTION BEHAVIOUR BY MACHINE TESTING

Insert a new Annex 8B, to read:

* has to be defined later

ANNEX 9

ILLUSTRATIONS

1. Brake disc

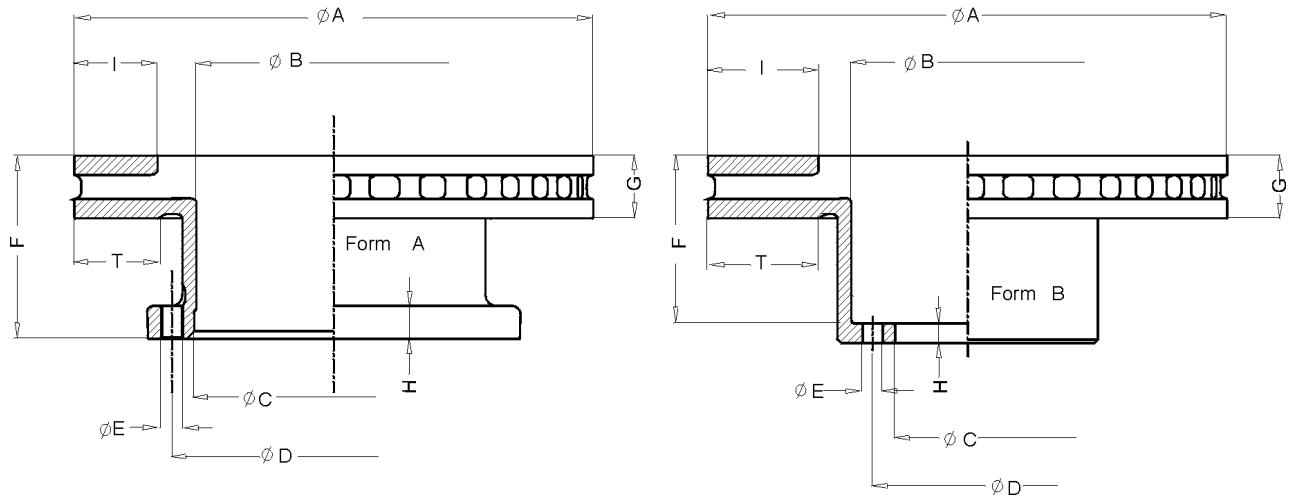

- A Outside disc diameter
- B Inside diameter of hat
- C Flange diameter
- D Pitch circle diameter x number of boreholes
- E Through hole/borehole for fixing
- F Fitting depth
- G Disc thickness
- H Bearing surface thickness
- I Inside width of friction ring
- T Width of the friction ring on the hat side

2 Brake drum

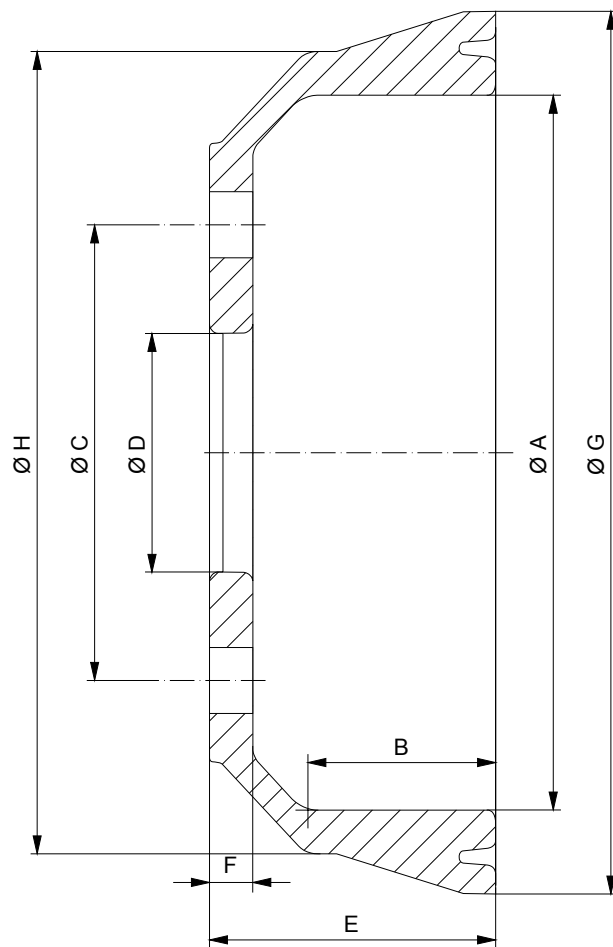

- A Inside diameter of the drum
- B Friction ring width
- C Pitch circle diameter x number of boreholes
- D Flange diameter
- E Outside drum height
- F Bearing surface thickness
- G Outside diameter of the drum
- H Casing diameter

3 Diagram of damage to the brake disc

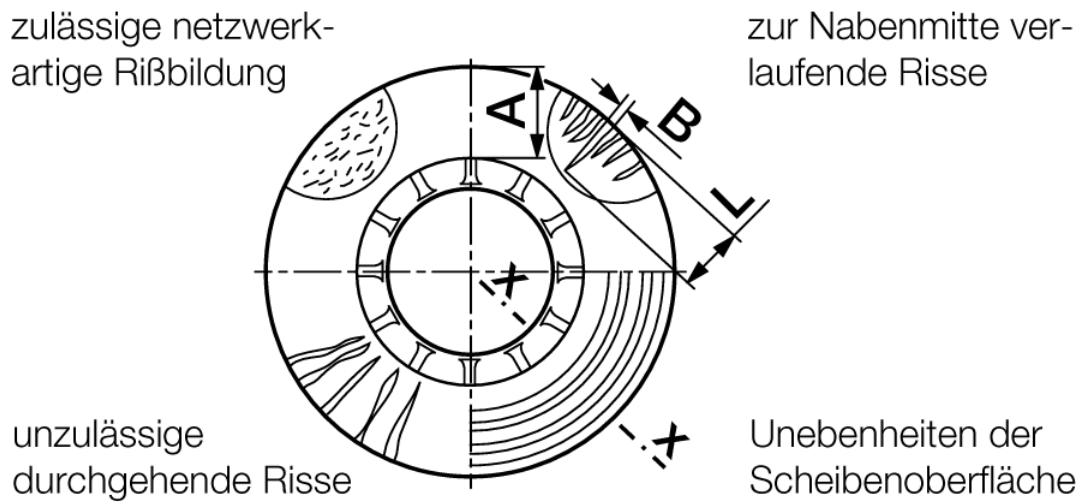

X - X
(gedreht gezeichnet)

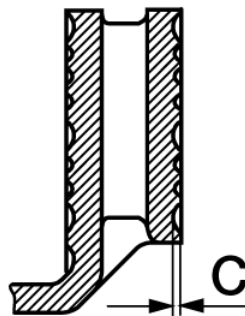

Key to diagram

- | | |
|--------------------------------------|---|
| zulässige netzwerkartige Rissbildung | = permissible lattice-like cracking |
| Zur Nabenmitte verlaufende Risse | = cracks running to the centre of the hub |
| unzulässige durchgehende Risse | = impermissible continuous cracks |
| Unebenheiten der Scheibenoberfläche | = unevenness in the surface of the disc |
| gedreht gezeichnet | = side-on view |

- A Friction ring width
- B Crack width
- C Tread depth
- L Crack length

A diagram of damage in the context of this regulation (see 4.1.1.1.3 and 4.1.1.2.3 in Annexes 10 and 11) is not provided if the following limit values are not exceeded:

Vehicle categories	M ₁ , M ₂ , N ₁ , N ₂ , O ₁ , O ₂	M ₃ , N ₃ , O ₃ , O ₄
Crack width B	0,2 mm	1,0 mm
Crack length L	0,5 x A	0,5 x A
Tread depth	0,2 mm	1,0 mm

ANNEX 10

REQUIREMENTS FOR REPLACEMENT BRAKE DISCS/DRUMS FOR VEHICLES OF CATEGORY M AND N

1 Verification of the statutory requirements in the road test

1.1 Test vehicle

A vehicle that is representative for the type in respect of which an approval or parts report for a replacement brake disc/drum is applied for shall be fitted with this replacement brake disc/drum as well as be equipped with test devices for testing the brakes pursuant to the provisions of ECE Regulation No 13.

The replacement brake disc/drum shall be fitted to the axle in question together with an accompanying original brake lining. Unless a uniform procedure is laid down for how braking is to be effected, the test shall be carried out following agreement with the Technical Service. All the tests listed below shall be carried out on brakes that have been bedded in. The same “bedding in” program shall be used for both replacement and original brake discs and drums.

2. Conformity with ECE Regulation No 13

Proof of compliance with the requirements laid down in ECE Regulation No 13 shall be furnished according to the respective vehicle type by means of the following tests stipulated in Table A10/2.1 A or Table A10/2.1 B:

2.1 Test overview

Table A10/2.1 A: Vehicles in categories M1, N1

Road test	Alternative dynamometer test
2.2.1 Type 0, engine disconnected	-
2.2.2 Type 0, engine connected	-
2.2.3 Type I *	-
2.3 Parking braking system (if required)	-
2.4 Testing the dynamic frictional properties (comparison test conducted on the individual axles)	3.5 Testing the dynamic frictional properties (comparison test conducted on the individual wheel brake))
* required by: - disc brakes - drum brake with modified cooling or modified surface contact area compared to the OE-part	

Table A10/2.1 B: Vehicles in categories M₂, M₃, N₂, N₃

Road test	Alternative dynamometer test
2.2.1 Type 0, engine disconnected	3.3.1 Type 0, engine disconnected
2.2.3 Type I *	3.3.2 Type I *
2.2.4 Type II	3.3.3 Type II
2.3 Parking braking system (if required)	3.4 Parking braking system (if required)
2.4 Testing the dynamic frictional properties (comparison test conducted on the individual axles)	3.5 Testing the dynamic frictional properties (comparison test conducted on the individual wheel brake)
* required by: - disc brakes - drum brake with modified cooling or modified surface contact area compared to the OE-part	

2.2 Service braking system

2.2.1 Type 0 brake tests, engine disconnected, vehicle laden

This test shall be carried out pursuant to ECE Regulation No 13, Annex 4, paragraph 1.4.2.

2.2.2 Type 0 brake tests, engine connected, vehicle unladen and laden

This test shall be carried out pursuant to ECE Regulation No 13, Annex 4, paragraph 1.4.3.1 (supplementary test, how the vehicle behaves when braking from high speed).

2.2.3 Type I brake tests

This test shall be carried out pursuant to ECE Regulation No 13, Annex 4, paragraph 1.5.1.

At the end of the Type I brake test, the performance when the brakes are hot is to be satisfied pursuant to ECE Regulation No 13, Annex 4, paragraph 1.5.3.

2.2.4 Type II brake tests

This test shall be carried out pursuant to ECE Regulation No 13, Annex 4, paragraph 1.6.

2.3 Parking braking system (if required)

2.3.1 Static test with 18% gradient, vehicle laden

2.3.2 The vehicle shall satisfy all the relevant provisions laid down in ECE Regulation No 13, Annex 4, Section 2.3 that apply to this category of vehicle.

2.4 Testing the dynamic frictional properties (comparison test conducted on the individual axles)

For this test, the vehicle shall be laden and all brake applications carried out on a flat road with the engine disconnected.

The service braking system of the vehicle shall be provided with a device that separates the front-wheel brakes from the rear-wheel brakes so that they can always be operated independently of one another.

If an approval or a parts report is required in connection with a replacement brake disc/drum for the front-wheel brakes, the rear-wheel brakes shall remain inoperative throughout the test.

If an approval or a parts report is required in connection with a replacement brake disc/drum for the rear-wheel brakes, the front-wheel brakes shall remain inoperative throughout the test.

2.4.1 Performance comparison test when the brakes are cold

With cold brakes, the performance of the replacement brake disc/drum shall be compared with the original equivalents by comparing the results of the test below.

2.4.1.1 Using the replacement brake disc/drum, at least six consecutive brake applications with different, gradually increasing control forces or brake pressures are carried out as part of the process up to the point at which the wheels lock, or up to a mean fully developed deceleration of 6 m/s² (M₁, M₂, N₁) or 3,5 m/s² (M₃, N₂, N₃) or up to the maximum control force permitted for this category of vehicle, in which connection the initial speed for the testing of front and rear axle brake discs and drums is as per the table below:

Table A10/2.4.1.1

Vehicle category	Test speed in km/h	
	Front axle	Rear axle
M ₁	70	45
M ₂	50	40
N ₁	65	50
M ₃ /N ₂ /N ₃	45	45

Prior to each brake application, the initial temperature of the brake disc/drum shall be ≤ 100° C.

2.4.1.2 The brake test described in 2.4.1.1 also has to be carried out using the original brake disc/drum.

2.4.1.3 The dynamic frictional properties of the replacement brake disc/drum can be regarded as similar to those of the original brake disc/drum, provided the values attained in relation to the mean fully developed deceleration at the same operating pressures or control forces in the region of the upper 2/3 of the curve generated do not deviate by more than ± 10% or ± 0.4 m/s² from those of the original brake disc/drum.

3 Verification of statutory requirements by means of tests conducted on the inertia dynamometer/testing the individual wheel brake

3.1 Equipping the dynamometer

For testing purposes, the dynamometer shall be fitted out with the original brake calliper or wheel brake of the vehicle concerned. The inertia dynamometer shall be equipped with devices for recording rotational speed, brake pressure, the number of revolutions after braking has commenced, brake torque, the braking period and the temperature of the brake discs/drums on a continuous basis.

3.2. Test conditions

3.2.1 Mass inertia of the inertia dynamometer

The mass inertia of the inertia dynamometer shall be set as close as possible, with a permissible variation of $\pm 5\%$, to the theoretically required value which corresponds to that part of the total inertia of the vehicle braked by the appropriate wheel. The formula used for calculation purposes is as follows:

$$I = m \cdot r_{\text{dyn}}^2$$

where:

I = rotary inertia (kgm^2);

r_{dyn} = dynamic tyre rolling radius (m);

m = proof mass (part of the maximum mass of the vehicle braked by the appropriate wheel) as stipulated by this regulation

3.2.1.1 Dynamic rolling radius

In calculating the inertia mass moment, the dynamic rolling radius (r_{dyn}) of the largest tyre authorised for the vehicle (or the axle) shall be taken into account.

3.2.1.2 Test mass

The test mass for calculating the inertia mass moment shall be as follows:

a) When testing front axle brake discs and drums:

$$m = \frac{x \cdot m_{Fz}}{2 \cdot n_{VA}}$$

m_{Fz} : max. permitted mass of the vehicle

n_{VA} : number of front axles

b) When testing rear axle brake discs and drums:

$$m = \frac{y \cdot m_{Fz}}{2 \cdot n_{HA}}$$

m_{Fz} : max. permitted mass of the vehicle

n_{HA} : number of rear axles

Table A10/3.2.1.2

Vehicle category	Percentage by mass m to be taken into account	
	X values (front axle)	Y values (rear axle)
M ₁	77	32
M ₂	69	44
N ₁	66	39
M ₃ /N ₂ /N ₃	55	55

- 3.2.2 The initial rotational speed of the dynamometer shall correspond to the linear speed of the vehicle of 80 km/h (M₁) or 60 km/h (M₂, M₃, N₁, N₂, N₃) based on the mean of the dynamic rolling radii of the largest and smallest tyre of the authorized tyre sizes.
- 3.2.3 The brakes may be cooled using air at the flow rate permitted by ECE-Regulation No. 13.
- 3.3 Service braking system
- 3.3.1 Type 0 brake tests, engine disconnected, vehicle laden
This test shall be carried out analogous to the provisions of ECE Regulation No 13, Annex 4, paragraph 1.4.2.
- 3.3.2 Brake tests type I
This test shall be carried out analogous to the provisions of ECE Regulation No 13, Annex 4, paragraph 1.5.1.
At the end of the Type I brake test, the performance when the brakes are hot is to be satisfied pursuant to ECE Regulation No 13, Annex 4, paragraph 1.5.3.
- 3.3.3 Brake tests type II
This test shall be carried out analogous to the provisions of ECE Regulation No 13, Annex 4, paragraph 1.6.
- 3.4 Parking braking system (if applicable)
Proof of compliance with the provisions listed in Section 2.3 of this Annex can be furnished by means of substitute tests.
- 3.5 Testing the dynamic frictional properties (comparison test conducted on the individual wheel brake)
With cold brakes, the performance of the replacement brake disc/drum shall be compared with the original equivalents by comparing the results of the test below.

- 3.5.1 Using the replacement brake disc/drum, at least six consecutive brake applications with different, gradually increasing control forces or brake pressures are carried out as part of the process up to a mean fully developed deceleration of 6 m/s² (M₁/M₂, N₁) or 5 m/s² (M₃, N₂/N₃). Prior to each brake application, the initial temperature of the brake disc/drum shall be ≤ 100° C.
- 3.5.2 The brake test described in 3.5.1 also has to be carried out using the original brake disc/drum.
- 3.5.3 The dynamic frictional properties of the replacement brake disc/drum can be regarded as similar to those of the original brake disc/drum, provided the values attained in relation to the mean fully developed deceleration at the same operating pressures or control forces in the region of the upper 2/3 of the curve generated do not deviate by more than ± 10% or ± 0.4 m/s² from those of the original brake disc/drum.
- 4 Dynamic component test on the inertia dynamometer
- Assessment of the dynamic component test is effected by means of the tests in 4.1 or 4.2.
- The respective tests shall be carried out on at least two uniform spare/special parts per test group, in which connection proof that one spare/special part satisfies requirements can be furnished by means of the in-house tests conducted by the part manufacturer.
- In terms of establishing an idea of the damage to the original equipment part as reference, the test only needs to be carried out on one component.
- The brakes are installed according to the fitting position in the vehicle (rigidly mounted brakes or those installed by means of a stub axle are exempt).
- The temperature may be recorded as the tester sees fit, but must remain the same for all the tests.
- 4.1 Brake discs
- 4.1.1 Crack resistance test
- This test is conducted using a brand-new disc and new linings without green coatings.
- 4.1.1.1 Vehicles of categories M1 / N1
- 4.1.1.1.1 Test conditions
- The mass inertia of the inertia dynamometer shall be determined in accordance with the requirements laid down in 3.2.1, 3.2.1.1 and 3.2.1.2 of Annex 1.
- The rotational speed of the dynamometer shall correspond to the linear test speed of the vehicle based on the mean of the largest and smallest dynamic rolling radius of the tyres authorised for that vehicle.

4.1.1.1.2 Test programme

Table A10/4.1.1.1.2

Test provision	Cracking
Vehicle categories	M ₁ / N ₁
Type of braking	Sequential brake applications
Braking interval (= t _{ges})	70 s
Number of brake applications per cycle	2
Brake torque in accordance with a [m/s ²]	5,0
Total number of braking cycles	100 Failure criteria ⇒ see paragraph 8.3 (diagram of damage)
Brake applications from to	0,8 v _{max} (maxsp) 20 km/h
Initial temperature of the 1st brake application in each cycle	≤ 100 °C

maxsp maximum design speed (as per its range of use)

t_{Brems} actual braking period during the test

t_{Beschl} minimum acceleration time in accordance with the accelerating power of the respective vehicle

t_H rest period

t_{ges} Braking interval (t_{Brems} + t_{Beschl} + t_H)

4.1.1.1.3 Test result

The test is regarded as having been passed if:

- once the 100 cycles are complete, the brake disc does not exhibit any signs of damage

or

- the level of damage is no worse compared with the original brake disc.

Damage in this context (see also para. 8.3) includes:

- The appearance of yawning cracks
- Demolition of the hat
- Through-cracking of the friction ring

4.1.1.2 Vehicles of categories $M_2 - M_3 - N_2 - N_3$

4.1.1.2.1 Test conditions

4.1.1.2.1.1 Vehicles with a maximum permissible mass $> 7,5$ t

By means of the following test programme, brake discs are tested as components of the braking system. It does not imitate actual driving conditions but is understood as being purely a component test. The parameters listed below in Table A10/4.1.1.2.1.1 cover the brakes that are presently used as a rule on vehicles with a maximum permitted mass 7,5 t.

Table A10/4.1.1.2.1.1

Outside disc diameter	Test parameter	Test parameter	Example of equipment
	Test mass m [kg]	r_{dyn} [m]	“Brake size”/smallest possible rim size
320 – 350	3100	0,386	17,5“
351 – 390	4500	0,445	19,5“
391 – 440	5300	0,527	22,5“
> 440*	*	*	-

* There is presently no empirical evidence available relating to these brake disc sizes. Tests using these brake discs shall be carried out in accordance with the state of the art.

The mass inertia of the inertia dynamometer shall be determined in accordance with the requirements laid down in 3.2.1 of Annex 1 in conjunction with the parameters specified in the table above (test mass and r_{dyn}).

The rotational speed of the dynamometer shall correspond to the linear test speed of the vehicle based on the dynamic tyre rolling radii specified in Table A10/4.1.1.2.1.1.

4.1.1.2.1.2 Vehicles with a maximum permissible mass $> 3,5$ t and $\leq 7,5$ t

As regards vehicles with a maximum permitted mass $> 3,5$ t and $\leq 7,5$ t in respect of which the parameters listed in Table A10/4.1.1.2.1.1 do not apply, the test parameters shall be selected in such a way that the worst case scenario that formed the basis of the range of use of the replacement brake disc (maximum permitted vehicle mass, maximum tyre equipment size) is covered. The mass inertia of the inertia dynamometer shall be determined in accordance with the requirements laid down in 3.2.1, 3.2.1.1 and 3.2.1.2 of Annex 1.

The rotational speed of the dynamometer shall correspond to the linear test speed of the vehicle based on the mean of the largest and smallest dynamic rolling radius of the tyres authorised for that vehicle.

4.1.1.2.2 Test programme

Table A10/4.1.1.2.2

„Bedding in” procedure	100 Brake applications Initial speed: 60 km/h Final speed: 30 km/h d_m alternating between 1 m/s ² and 2 m/s ² Initial temperature : $\leq 300^\circ\text{C}$ (beginning at room temperature)
1. Conditioned braking	10 Brake applications from 60 to 30 km/h d_m alternating between 1 m/s ² and 2 m/s ² Initial temperature: $\leq 250^\circ\text{C}$
2. High-speed braking	2 Brake applications from 130 to 80 km/h d_m 3 m/s ² Initial temperature: $\leq 100^\circ\text{C}$
3. Conditioned braking	see test stage 1
4. High-speed braking	see test stage 2
5. Conditioned braking	see test stage 1
6. Continuous braking (1)	5 Brake applications at a constant speed of: 85 km/h Decelerating torque corresponding to 0,5 m/s ² Braking period 60 s Initial temperature: $\leq 80^\circ\text{C}$
7. Conditioned braking	see test stage 1
8. Continuous braking (2)	5 Brake applications at a constant speed of: 85 km/h Decelerating torque corresponding to 1,0 m/s ² Braking period 40 s Initial temperature: $\leq 80^\circ\text{C}$
9. Repeat test stages 1 to 8:	9 times

d_m distance-related mean deceleration

4.1.1.2.3 Test result

The test is regarded as having been passed if:

- once the 10 cycles are complete, the brake disc does not exhibit any signs of damage or
- the level of damage is no worse compared with the original brake disc.

Damage in this context (see also para. 8.3) includes

- The appearance of yawning cracks
- Demolition of the hat
- Through-cracking of the friction ring

4.1.2 Strength test

The strength test shall be conducted on the same test specimens following the positive crack resistance test.

4.1.2.1 Vehicles of categories $M_1 - N_1$

4.1.2.1.1 Test conditions

see above paragraph 4.1.1.1.1

4.1.2.1.2 Test programme

The test has to be carried out according to the following table:

Table A10/4.1.2.1.2

Test provision	Strength test
Vehicle categories	M_1 / N_1
Type of braking	Single brake applications
Number of brake applications	50
Initial temperature at the beginning of braking	$\leq 100 \text{ }^\circ\text{C}$
Brake torque in accordance with a [m/s^2]	10,0 (however, brake pressure $p_{\text{max}} \leq 160 \text{ bar}$)
Brake applications from to	100 km/h 10 km/h

4.1.2.2 Vehicles of categories $M_2 - M_3 - N_2 - N_3$

4.1.2.2.1 Test conditions

see above paragraph 4.1.1.2.1

4.1.2.2.2 Test programme

500 brake applications are carried out from a speed of 50 km/h to 10 km/h with a brake torque of 90% of the maximum brake torque specified by the applicant.

Initial temperature: $\leq 200^\circ\text{C}$

4.1.2.2.3 Test result

The test is regarded as having been passed if the brake disc does not exhibit any signs of fracture after 500 brake applications.

4.2 Brake drums

4.2.1 Crack resistance test

This test is conducted using a brand-new drum and new linings.

4.2.1.1 Vehicles of categories M und N

This test is conducted using a brand-new drum and new linings.

4.2.1.1.1 Test conditions

The mass inertia of the inertia dynamometer shall be determined in accordance with the requirements laid down in 3.2.1, 3.2.1.1 and 3.2.1.2 of Annex 1.

The rotational speed of the dynamometer shall correspond to the linear test speed of the vehicle based on the mean of the largest and smallest dynamic rolling radius of the tyres authorised for that vehicle.

4.2.1.1.2 Test programme

Table A10/4.2.1.1.2

Test provision	
Type of braking	Sequential brake applications
Number of brake applications	300 <u>NB:</u> The test is interrupted when a through crack appears.
Brake torque in accordance with a $[m/s^2]$	3,0

Brake applications from to	130 80 km/h
Initial temperature of each brake application	≤ 50 °C
Cooling pursuant to 3.2.3	permitted

4.2.1.1.3 Test result

The test is regarded as having been passed if:

- once the 300 brake applications are complete, no through-crack appears and the maximum crack length is not greater than 25% of the shoe width - or
- the level of damage is no worse compared with the original brake drum.

4.2.2 Strength test

The strength test shall be conducted on the same test specimens following the crack resistance test.

4.2.2.1 Vehicles of categories M und N

The strength test shall be carried out on motor vehicles where the permitted static axle load mass exceeds 1200 kg.

4.2.2.1.1 Test conditions

The mass inertia of the inertia dynamometer shall be determined in accordance with the requirements laid down in 3.2.1, 3.2.1.1 and 3.2.1.2 of Annex 1.

The rotational speed of the dynamometer shall correspond to the linear test speed of the vehicle based on the mean of the largest and smallest dynamic rolling radius of the tyres authorised for that vehicle.

4.2.2.1.2 Test programme

Table A10/4.2.1.2

Test provision	
Type of braking	Brakings to standstill
Total number of brake applications	150
Initial temperature of the brake drum [°C] every time the brake is operated	100
Brake applications from [km] to [km]	60 0

Brake torque in accordance with a [m/s ²]	6
Cooling (also deviating from para. 3.2.3)	permitted

4.2.2.1.3 Test result

The test result is positive provided the brake drum does not fracture.

5 Material testing

The following tests (5.1 to 5.3) are necessary if the manufacturer is not able to present work's test certificate(s) "2.3" or inspection certificate(s) "3.1.B" as per DIN EN 10204 "Metallic materials – Types of inspection documents".

5.1 Chemical material analysis

5.2 Brinell hardness pursuant to DIN 50351

5.3 Tensile strength in accordance with DIN 50 109 (sampling as per DIN 1691) or, alternatively, the wedge penetration test pursuant to consultative document P340 (presently, as at November 1994) for grey cast iron materials.

ANNEX 11

REQUIREMENTS FOR REPLACEMENT BRAKE DISCS/DRUMS FOR VEHICLES OF CATEGORY O

1 Verification of the statutory requirements in the road test

1.1 Test vehicle

A vehicle that is representative for the type in respect of which an approval or parts report for a replacement brake disc/drum is applied for shall be fitted with this replacement brake disc/drum as well as be equipped with test devices for testing the brakes pursuant to the provisions of ECE Regulation No 13.

The replacement brake disc/drum shall be fitted to the axle in question together with an accompanying original brake lining. Unless a uniform procedure is laid down for how braking is to be effected, the test shall be carried out following agreement with the Technical Service. All the tests listed below shall be carried out on brakes that have been bedded in. The same “bedding in” programme shall be used for both replacement and original brake discs and drums.

2. Conformity with ECE Regulation No 13

Proof of compliance with the requirements laid down in ECE Regulation No 13 shall be furnished according to the respective vehicle type by means of the following tests stipulated in Table A11/2.1 A or Table A11/2.1 B:

2.1 Test overview

Table A11/2.1 A: Vehicles of categories O₂, O₃

Track test	Alternative dynamometer test
2.2.1 Type 0	3.3.1 Type 0
2.2.2 Type I *	3.3.2 Type I *
2.3 Parking brake system (if applicable)	3.4 Parking brake system (if applicable)
2.4 Testing the dynamic frictional properties (comparison test conducted on the individual axles)	3.5 Testing the dynamic frictional properties (comparison test conducted on the individual axles)
* required by: - disc brakes - drum brake with modified cooling or modified surface contact area compared to the OE-part	

Table A11/2.1 B: Vehicles of categories O₄

Track test	Alternative dynamometer test
2.2.1 Type 0	3.3.1 Type 0
2.2.3 Type III*	3.3.3 Type III*
2.3 Parking brake system (if applicable)	3.4 Parking brake system (if applicable)
2.4 Testing the dynamic frictional properties (comparison test conducted on the individual axles)	3.5 Testing the dynamic frictional properties (comparison test conducted on the individual axles)
* required by: <ul style="list-style-type: none"> - disc brakes - drum brake with modified cooling or modified surface contact area compared to the OE-part 	

2.2 Service braking system

2.2.1 Brake tests type 0, vehicle laden

This test shall be carried out pursuant to ECE Regulation No 13, Annex 4, paragraph 1.4.4.

2.2.2 Brake tests type I

This test shall be carried out pursuant to ECE Regulation No 13, Annex 4, paragraph 1.5.2.

At the end of the Type I brake test, the performance when the brakes are hot is to be satisfied pursuant to ECE Regulation No 13, Annex 4, paragraph 1.5.3.

2.2.3 Brake tests type III

This test shall be carried out pursuant to ECE Regulation No 13, Annex 4, Section 1.7.

2.3 Parking braking system (if applicable)

2.3.1 Static test with 18% gradient, vehicle laden

2.3.2 The vehicle shall satisfy all the relevant provisions laid down in ECE Regulation No 13, Annex 4, paragraphs 2.3 and 3.2 that apply to this category of vehicle.

2.4 Testing the dynamic frictional properties (comparison test conducted on the individual axles)

For this test, the vehicle shall be laden and all brake applications carried out on a flat road.

The service braking system of the vehicle shall be provided with a device that separates the front-wheel brakes from the rear-wheel brakes so that they can always be operated independently of one another.

If an approval or a parts report is required in connection with a replacement brake disc/drum for the front-wheel brakes, the rear-wheel brakes shall remain inoperative throughout the test.

If an approval or a parts report is required in connection with a replacement brake disc/drum for the rear-wheel brakes, the front-wheel brakes shall remain inoperative throughout the test.

2.4.1 Performance comparison test when the brakes are cold

With cold brakes, the performance of the replacement brake disc/drum shall be compared with the original equivalents by comparing the results of the test below

2.4.1.1 Using the replacement brake disc/drum, at least six consecutive brake applications with different, gradually increasing control forces or brake pressures are carried out as part of the process up to the point at which the wheels lock, or up to a mean fully developed deceleration of 3.5 m/s^2 , or up to the maximum control force permitted for this category of vehicle, in which connection the initial speed for testing purposes is 45 km/h:

Prior to each brake application, the initial temperature of the brake drum shall be $\leq 100^\circ \text{ C}$.

2.4.1.2 The brake test described in 2.4.1.1 also has to be carried out using the original brake disc/drum.

2.4.1.3 The dynamic frictional properties of the replacement brake disc/drum can be regarded as similar to those of the original brake disc/drum, provided the values attained in relation to the mean fully developed deceleration at the same operating pressures or control forces in the region of the upper 2/3 of the curve generated do not deviate by more than $\pm 15\%$ or $\pm 0.4 \text{ m/s}^2$ from those of the original brake disc/drum.

3 Verification of statutory requirements by means of tests conducted on the inertia dynamometer/testing the individual wheel brake

3.1 Equipment of the dynamometer

For testing purposes, the dynamometer shall be fitted out with the original wheel brake of the vehicle concerned. The inertia dynamometer shall be equipped with devices for recording rotational speed, brake pressure, the number of revolutions after braking has commenced, brake torque, the braking period and the temperature of the brake drum on a continuous basis.

3.2. Test conditions

3.2.1 Mass inertia of the inertia dynamometer

The mass inertia of the inertia dynamometer shall be set as close as possible, with a permissible variation of $\pm 5\%$, to the theoretically required value which corresponds to that part of the total inertia of the vehicle braked by the appropriate wheel. The formula used for calculation purposes is as follows:

$$I = m \cdot r_{\text{dyn}}^2$$

where:

I = rotary inertia (kgm^2);

r_{dyn} = dynamic tyre rolling radius (m);

m = proof mass (part of the maximum mass of the vehicle braked by the appropriate wheel) as stipulated by this regulation

3.2.1.1 Dynamic rolling radius

In calculating the inertia mass moment, the dynamic rolling radius (r_{dyn}) of the largest tyre authorised for the vehicle (or the axle) shall be taken into account.

3.2.1.2 Test mass

The test mass for calculating the inertia mass moment shall be as follows:

a) When testing brake discs and drums of full trailers:

$$m = \frac{0,55 \cdot m_{Fz}}{2 \cdot n}$$

m_{Fz} : max. permitted mass of the vehicle

n : number of front- or rear-axles

b) When testing brake discs and drums of semi-trailers or centre-axle trailers:

$$m = \frac{0,55 \cdot m_{Fz}}{2 \cdot n}$$

m_{Fz} : max. permitted mass of the vehicle

n : number of axles

3.2.2 The initial rotational speed of the dynamometer shall correspond to the linear speed of the vehicle of 60 km/h based on the smallest dynamic tyre rolling radius.

3.2.3 The brakes may be cooled using air at the flow rate permitted by ECE-Regulation No. 13.

- 3.3 Service braking system
- 3.3.1 Brake tests type 0, vehicle laden
- This test shall be carried out analogous to the provisions of ECE Regulation No 13, Annex 4, paragraph 1.4.4.
- 3.3.2 Brake tests type I
- This test shall be carried out analogous to the provisions of ECE Regulation No 13, Annex 4, paragraph 1.5.2.
- At the end of the Type I brake test, the performance when the brakes are hot is to be satisfied pursuant to ECE Regulation No 13, Annex 4, paragraph 1.5.3.
- 3.3.3 Brake tests type III
- This test shall be carried out analogous to the provisions of ECE Regulation No 13, Annex 4, Section 1.7.
- 3.4 Parking braking system (if applicable)
- Proof of compliance with the provisions listed in Section 2.3 of this Annex can be furnished by means of substitute tests.
- 3.5 Testing the dynamic frictional properties (comparison test conducted on the individual wheel brake)
- With cold brakes, the performance of the replacement brake disc/drum shall be compared with the original equivalents by comparing the results of the test below.
- 3.5.1 Using the replacement brake disc/drum, at least six consecutive brake applications with different, gradually increasing control forces or brake pressures are carried out as part of the process to a mean fully developed deceleration of 5 m/s². Prior to each brake application, the initial temperature of the brake drum shall be ≤ 100°C
- 3.5.2 The brake test described in 3.5.1 also has to be carried out using the original brake disc/drum.
- 3.5.3 The dynamic frictional properties of the replacement brake disc/drum can be regarded as similar to those of the original brake disc/drum, provided the values attained in relation to the mean fully developed deceleration at the same operating pressures or control forces in the region of the upper 2/3 of the curve generated do not deviate by more than ± 10% or ± 0.4 m/s² from those of the original brake disc/drum.

4 Dynamic component test on the inertia dynamometer

Assessment of the dynamic component test is effected by means of the tests in 4.1 or 4.2.

The respective tests shall be carried out on at least two uniform spare/special parts per test group, in which connection proof that one spare/special part satisfies requirements can be furnished by means of the in-house tests conducted by the part manufacturer.

In terms of establishing an idea of the damage to the original equipment part as reference, the test only needs to be carried out on one component.

The brakes are installed according to the fitting position in the vehicle (rigidly mounted brakes or those installed by means a stub axle are exempt).

The temperature may be recorded as the tester sees fit, but must remain the same for all the tests.

4.1 Brake discs

4.1.1 Crack resistance test

This test is conducted using a brand-new disc and new linings without „green coating”.

4.1.1.1 Vehicles of categories O₁ / O₂

4.1.1.1.1 Test conditions

The mass inertia of the inertia dynamometer shall be determined in accordance with the requirements laid down in 3.2.1, 3.2.1.1 and 3.2.1.2 of Annex 1.

The rotational speed of the dynamometer shall correspond to the linear test speed of the vehicle based on the mean of the largest and smallest dynamic rolling radius of the tyres authorised for that vehicle.

4.1.1.1.2 Test programme

Table A11/4.1.1.1.2

Test provision	Cracking
Vehicle categories	O ₁ / O ₂
Type of braking	Sequential brake applications
Braking interval (= t _{ges})	70 s
Number of brake applications per cycle	2
Brake torque in accordance with a [m/s ²]	5,0
Total number of braking cycles	250 Failure criteria ⇒ see paragraph 8.3 (diagram of damage)
Brake applications from to	0,9 v _{max} (maxsp) 20 km/h
Initial temperature of the 1st brake application in each cycle	≤ 100 °C

maxsp maximum design speed (as per its range of use)

t_{Brems} actual braking period during the test

t_{Beschl} minimum acceleration time in accordance with the accelerating power of the respective vehicle

t_H rest period

t_{ges} Braking interval (t_{Brems} + t_{Beschl} + t_H)

4.1.1.1.3 Test result

The test is regarded as having been passed if:

- once the 250 cycles are complete, the brake disc does not exhibit any signs of damage

or

- the level of damage is no worse compared with the original brake disc.

Damage in this context (see also para. 8.3) includes:

- The appearance of yawning cracks
- Demolition of the hat
- Through-cracking of the friction ring

4.1.1.2 Vehicles of categories O₃ und O₄

4.1.1.2.1 Test conditions

4.1.1.2.1.1 Vehicles with a maximum permissible mass > 7,5 t

By means of the following test programme, brake discs are tested as components of the braking system. It does not imitate actual driving conditions but is understood as being purely a component test. The parameters listed below in Table A11/4.1.1.2.1.1 cover the brakes that are presently used as a rule on vehicles with a maximum permitted mass > 7,5 t.

Table A11/4.1.1.2.1.1

Outside disc diameter	Test parameter	Test parameter	Example of equipment
	Test mass m [kg]	r _{dyn} [m]	“Brake size”/smallest possible rim size
320 – 350	3100	0,386	17,5“
351 – 390	4500	0,445	19,5“
391 – 440	5300	0,527	22,5“
> 440*	*	*	-

* There is presently no empirical evidence available relating to these brake disc sizes. Tests using these brake discs shall be carried out in accordance with the state of the art.

The mass inertia of the inertia dynamometer shall be determined in accordance with the requirements laid down in 3.2.1 of Annex 2 in conjunction with the parameters specified in the table above (test mass and r_{dyn}).

The rotational speed of the dynamometer shall correspond to the linear test speed of the vehicle based on the dynamic tyre rolling radii specified in Table A11/4.1.1.2.1.1.

4.1.1.2.1.2 Vehicles with a maximum permissible mass $> 3,5$ t and $\leq 7,5$ t

As regards vehicles with a maximum permitted mass > 3.5 t and ≤ 7.5 t in respect of which the parameters listed in Table A11/4.1.1.2.1.1 do not apply, the test parameters shall be selected in such a way that the worst case scenario that formed the basis of the range of use of the replacement brake disc (maximum permitted vehicle mass, maximum tyre equipment size) is covered.

The mass inertia of the inertia dynamometer shall be determined in accordance with the requirements laid down in 3.2.1, 3.2.1.1 and 3.2.1.2 of Annex 2.

The rotational speed of the dynamometer shall correspond to the linear test speed of the vehicle based on the mean of the largest and smallest dynamic rolling radius of the tyres authorised for that vehicle.

4.1.1.2.2 Test programme

Table A11/4.1.1.2.2

„Bedding in” procedure	100 Brake applications Initial speed: 60 km/h Final speed: 30 km/h d_m alternating between 1 m/s ² und 2 m/s ² Initial temperature : ≤ 300°C (beginning at room temperature)
1. Conditioned braking	10 Brake applications from 60 to 30 km/h d_m alternating between 1 m/s ² und 2 m/s ² Initial temperature : ≤ 250°C
2. High-speed braking	2 Brake applications from 130 to 80 km/h $d_m = 3 \text{ m/s}^2$ Initial temperature: ≤ 100°C
3. Conditioned braking	see test stage 1
4. High-speed braking	see test stage 2
5. Conditioned braking	see test stage 1
6. Continuous braking (1)	5 Brake applications at a constant speed of: 85 km/h Decelerating torque corresponding to 0,5 m/s ² Braking period 60 s Initial temperature: ≤ 80°C
7. Conditioned braking	see test stage 1
8. Continuous braking (2)	5 Brake applications at a constant speed of: 85 km/h Decelerating torque corresponding to 1,0 m/s ² Braking period 40 s Initial temperature: ≤ 80°C
9. Repeat test stages 1 to 8:	9 times

d_m distance-related mean deceleration

4.1.1.2.3 Test result

The test is regarded as having been passed if:

- once the 10 cycles are complete, the brake disc does not exhibit any signs of damage or
- the level of damage is no worse compared with the original brake disc.

Damage in this context (see also para. 8.3) includes:

- The appearance of yawning cracks
- Demolition of the hat
- Through-cracking of the friction ring

4.1.2 Strength test

The strength tests shall be conducted on the same test specimens following the crack resistance test.

4.1.2.1 Vehicles of categories O₁ und O₂
not applicable4.1.2.2 Vehicles of categories O₃ und O₄

4.1.2.2.1 Test conditions

see above paragraph 4.1.1.2.1

4.1.2.2.2 Test programme

500 brake applications are carried out from a speed of 50 km/h to 10 km/h with a brake torque of 90% of the maximum brake torque specified by the applicant.

Initial temperature: $\leq 200^{\circ}\text{C}$

4.1.2.2.3 Test result

The test is regarded as having been passed if the brake disc does not exhibit any signs of fracture after 500 brake applications.

4.2 Brake drums

4.2.1 Crack resistance test

This test is conducted using a brand-new drum and new linings.

4.2.1.1 Vehicles in category O

Crack resistance tests shall be carried out on towed vehicles where the permitted static axle load mass exceeds 1200 kg.

4.2.1.1.1 Test conditions

The mass inertia of the inertia dynamometer shall be determined in accordance with the requirements laid down in 3.2.1, 3.2.1.1 and 3.2.1.2 of Annex 1.

The rotational speed of the dynamometer shall correspond to the linear test speed of the vehicle based on the mean of the largest and smallest dynamic rolling radius of the tyres authorised for that vehicle.

4.2.1.1.2 Test programme

Table A11/4.2.1.1.2

Test provision	
Type of braking	Sequential brake applications
Number of brake applications	300 <u>NB:</u> The test is interrupted when a through crack appears.
Brake torque in accordance with a [m/s ²]	3,0
Brake applications from to	130 80 km/h
Initial temperature of each brake application	≤ 50 °C
Cooling pursuant to 3.2.3	permitted

4.2.1.1.3 Test result

The test is regarded as having been passed if:

- once the 300 brake applications are complete, no through-crack appears and the maximum crack length is not greater than 25% of the shoe width - or
- the level of damage is no worse compared with the original brake drum.

4.2.2 Strength test

The strength test shall be conducted on the same test specimens following the crack resistance test.

4.2.2.1 Vehicles in category O

The strength test shall be carried out on towed vehicles where the permitted static axle load mass exceeds 1200 kg.

4.2.2.2 Test conditions

The mass inertia of the inertia dynamometer shall be determined in accordance with the requirements laid down in 3.2.1, 3.2.1.1 and 3.2.1.2 of Annex 1.

The rotational speed of the dynamometer shall correspond to the linear test speed of the vehicle based on the mean of the largest and smallest dynamic rolling radius of the tyres authorised for that vehicle.

4.2.2.3 Test programme

Table A11/4.2.2.3

Test provision	
Type of braking	Brakings to standstill
Total number of brake applications	150
Initial temperature of the brake drum [°C] every time the brake is operated	100
Brake applications from [km]	60
to [km]	0
Brake torque in accordance with a [m/s ²]	6
Cooling (also deviating from para. 3.2.3)	permitted

4.2.2.4 Test result

The test result is positive provided the brake drum does not fracture.

- 5 Material testing
The following tests (5.1 to 5.3) are necessary if the manufacturer is not able to present work's test certificate(s) "2.3" or inspection certificate(s) "3.1.B" as per DIN EN 10204 "Metallic materials – Types of inspection documents".
- 5.1 Chemical material analysis
- 5.2 Brinell hardness pursuant to DIN 50351
- 5.3 Tensile strength in accordance with DIN 50 109 (sampling as per DIN 1691) or, alternatively, the wedge penetration test pursuant to consultative document P340 (presently, as at November 1994) for grey cast iron materials.

ANNEX 12

REQUIREMENTS FOR REPLACEMENT BRAKE DISCS/DRUMS FOR VEHICLES OF CATEGORY L

1. Conformity with ECE Regulation No 78

Proof of conformity with the requirements laid down in ECE Regulation No 78 shall be furnished in the form of a vehicle test.
- 1.1 Test vehicle

A vehicle that is representative for the type in respect of which an approval or parts report for a replacement brake disc/drum is applied for shall be fitted with this replacement brake disc/drum as well as be equipped with test devices for testing the brakes pursuant to the provisions of ECE Regulation No 78.
- 1.2 The replacement brake disc/drum shall be fitted to the axle in question together with accompanying original brake linings or, in the case of brake discs/drums that are to be used exclusively in combination with other, non-serial brake linings, with this type of brake lining and, unless a uniform procedure is laid down for how braking is to be effected, subjected to braking according to the information provided by the brake lining manufacturer or as per the stipulations of the Technical Service which conducts the test.
- 1.3 As regards replacement brake discs/drums for vehicles with a combined braking system within the meaning of paragraph 2.9 of Regulation No 78, the replacement brake disc/drum shall be tested in all combinations with the corresponding wheel brakes (brake linings and/or brake discs and drums) on the other axle to which the approval is to apply.
2. Verification of the statutory requirements in the road test
 - 2.1. The braking system of the vehicle shall be tested in accordance with the requirements for the vehicle category in question (L1, L2, L3, L4 or L5) as laid down in ECE Regulation No 78, Annex 3 Section 1. The requirements or tests to be applied are as follows:
 - 2.1.1. Brake tests type 0, engine disconnected

The test shall only be carried out when the vehicle is laden. At least six consecutive brake applications with different, gradually increasing control forces or brake pressures are carried out as part of the process up to the point at which the wheels lock, or up to a mean fully developed deceleration of 6 m/s^2 , or up to the maximum control force permitted for this category of vehicle.

- 2.1.2 Brake tests type 0, engine connected
This test shall only be carried out on vehicles in categories L3, L4 and L5.
- 2.1.3 Brake tests type 0 with wet brakes
It is not necessary to carry out these brake tests in the case of category L5 vehicles or with drum brakes or fully encased disc brakes.
- 2.1.4 Brake tests type I
This test is only to be carried out on category L3, L4 and L5 vehicles.
- 2.2 The vehicle shall satisfy all the relevant requirements pertaining to this category of vehicle as stipulated in ECE Regulation No 78, Annex 3 Section 2.
- 3 Additional requirements
- 3.1 Performance comparison test with cold brakes
With cold brakes, the performance of the replacement brake disc/drum shall be compared with the original equivalents by comparing the results of the Type 0 brake tests pursuant to 2.1.1.
- 3.1.1 The Type 0 brake test described in 2.1.1 shall also be carried out using the original brake disc/drum.
- 3.1.2 The dynamic frictional properties of the replacement brake disc/drum can be regarded as similar to those of the original brake disc/drum, provided the values attained in relation to the mean fully developed deceleration at the same operating pressures or control forces in the region of the upper 2/3 of the curve generated do not deviate by more than $\pm 15\%$ or $\pm 0.4 \text{ m/s}^2$ from those of the original brake disc/drum. The satisfactory proportioning of the braking system shall be guaranteed.
- 4 Strength test conducted on the inertia dynamometer
As a strength test on the inertia dynamometer, sequential brake applications are conducted under the following test conditions for repeated loading of the component's replacement brake disc/drum with overlapping mechanical and thermal stresses:
- 4.1 Equipment of the dynamometer
For testing purposes, the dynamometer shall be fitted out with the original brake calliper or wheel brake of the vehicle in question. The inertia dynamometer shall be equipped with devices that enable deceleration, speed, time, distance, brake pressure, brake torque, brake disc temperature and brake lining temperature to be recorded on a continuous basis.

4.2 Test conditions

From every test group, the heaviest/fastest type (differentiating between single and dual disc brakes) – speed-dependant cooling, is taken.

4.2.1 Front-wheel brake

Equivalent inertia mass: 75% of the maximum permitted mass of the vehicle

Conditioning				
Step:	from [km/h]	to [km/h]	a [m/s ²]	t [s]
1	80	40	-3	3,7
2	40	80	3	3,7
3	80	80	-	20
Repeat steps 1 to 3 nineteen times				

Emergency stop				
Step:	from % v _{max}	to % v _{max}	a [m/s ²]	t [s]
1	80	0	-10	0,08 · v _{max} (v in m/s)
2	0	80	3	0,27 · v _{max} (v in m/s)
3	80	80	0	240

Drive profile				
Step:	from % v _{max}	to % v _{max}	a [m/s ²]	t [s]
1	80	40	-8	0,05 · v _{max} (v in m/s)
2	40	80	6	0,05 · v _{max} (v in m/s)
3	80	20	-8	0,075 · v _{max} (v in m/s)
4	20	80	6	0,1 · v _{max} (v in m/s)
5	80	40	-8	0,05 · v _{max} (v in m/s)
6	40	60	6	0,033 · v _{max}

Drive profile				
Step:	from % v_{\max}	to % v_{\max}	a [m/s^2]	t [s]
				(v in m/s)
7	60	40	-6	$0,033 \cdot v_{\max}$ (v in m/s)
8	40	60	6	$0,033 \cdot v_{\max}$ (v in m/s)
9	60	40	-6	$0,033 \cdot v_{\max}$ (v in m/s)
10	40	80	6	$0,067 \cdot v_{\max}$ (v in m/s)
11	80	60	-8	$0,025 \cdot v_{\max}$ (v in m/s)
12	60	60	-	10
13	60	40	-6	$0,033 \cdot v_{\max}$ (v in m/s)
14	40	80	6	$0,067 \cdot v_{\max}$ (v in m/s)
Repeat steps 1 to 14 twenty-nine times				

4.2.2 Rear-wheel brake

Equivalent inertia mass: 55% of the maximum permitted mass of the vehicle

Conditioning				
Step:	from [km/h]	to [km/h]	a [m/s ²]	t [s]
1	80	40	-2	5,56
2	40	80	3	3,7
3	80	80	-	20
Repeat steps 1 to 3 nineteen times				

Emergency stop				
Step:	from % v _{max}	to % v _{max}	a [m/s ²]	t [s]
1	50	0	-5	0,1 · v _{max} (v in m/s)
2	0	50	3	0,17 · v _{max} (v in m/s)
3	50	50	0	240

Drive profile				
Step:	from % v _{max}	to % v _{max}	a [m/s ²]	t [s]
1	50	20	-3	0,1 · v _{max} (v in m/s)
2	20	50	6	0,05 · v _{max} (v in m/s)
3	50	10	-3	0,14 · v _{max} (v in m/s)
4	10	50	6	0,067 · v _{max} (v in m/s)
5	50	20	-3	0,1 · v _{max} (v in m/s)
6	20	40	6	0,033 · v _{max} (v in m/s)
7	40	10	-2	0,15 · v _{max} (v in m/s)
8	10	40	6	0,05 · v _{max} (v in m/s)

Drive profile				
Step:	from % v_{\max}	to % v_{\max}	a [m/s^2]	t [s]
9	40	10	-2	$0,15 \cdot v_{\max}$ (v in m/s)
10	10	50	6	$0,067 \cdot v_{\max}$ (v in m/s)
11	50	20	-3	$0,1 \cdot v_{\max}$ (v in m/s)
12	20	40	6	$0,033 \cdot v_{\max}$ (v in m/s)
13	40	10	-2	$0,15 \cdot v_{\max}$ (v in m/s)
14	10	50	6	$0,067 \cdot v_{\max}$ (v in m/s)
Repeat steps 1 to 14 twenty-nine times				

4.3 Assessment criteria:

- a) Braking system behaviour during and between applications (performance, marches of temperature)
 - b) After the driving cycle, general inspection of the replacement brake disc/drum for mechanical damage, primarily cracking in the surface contact areas and in places that are especially at risk mechanically speaking (perforation holes, grooves etc.), as well as for signs of exceptional wear and tear or residual deformation. Additional assessment of the brake linings in terms of sturdiness of the lining and wear and tear.
 - c) If changes pursuant to b) occur, a comparison with the original equipment part is necessary.
 - d) The damage to the replacement part may not be worse compared with the original equipment part.
-