

DRAFT PROPOSAL:
GLOBAL TECHNICAL REGULATION

**LIGHTING AND LIGHT-SIGNALLING DEVICES FOR ROAD VEHICLE
- INSTALLATION PROVISIONS FOR VEHICLES OTHER THAN MOTORCYCLES**

Transmitted by the expert from Canada

Text of the document is based on TRANS/WP.29/GRE/2001/6/Rev.2. Proposed text modifications are indicated by revision marks: additions are underlined and strike-through characters mark deletions.

DRAFT

GLOBAL TECHNICAL REGULATION

LIGHTING AND LIGHT-SIGNALLING DEVICES FOR ROAD VEHICLE: INSTALLATION PROVISIONS FOR VEHICLES OTHER THAN MOTORCYCLES

TABLE OF CONTENT:

1. SCOPE AND PURPOSE
2. APPLICATION
3. DEFINITIONS
4. GENERAL SPECIFICATIONS
5. INDIVIDUAL SPECIFICATIONS
 - 5.1. DRIVING BEAM HEADLAMP
 - 5.2. PASSING BEAM HEADLAMP
 - 5.3. FRONT FOG LAMP
 - 5.4. REVERSING LAMP
 - 5.5. DIRECTION INDICATOR LAMP
 - 5.6. HAZARD WARNING SIGNAL
 - 5.7. STOP LAMP
 - 5.8. REAR REGISTRATION PLATE ILLUMINATING DEVICE
 - 5.9. FRONT POSITION LAMP
 - 5.10. REAR POSITION LAMP
 - 5.11. REAR FOG LAMP
 - 5.12. PARKING LAMP
 - 5.13. END-OUTLINE MARKER LAMP

- 5.14. REAR RETRO-REFLECTOR, NON-TRIANGULAR
- 5.15. REAR RETRO-REFLECTOR, TRIANGULAR
- 5.16. FRONT RETRO-REFLECTOR, NON-TRIANGULAR
- 5.17. SIDE RETRO-REFLECTOR, NON-TRIANGULAR
- 5.18. SIDE-MARKER LAMPS
- 5.19. DAYTIME RUNNING LAMP
- 5.20. IDENTIFICATION LAMPS
- 5.21. CORNERING LAMP
- 5.22. CONSPICUITY TREATMENT

- Annex 1 LAMP SURFACES, AXIS AND CENTRE OF REFERENCE, AND ANGLES OF GEOMETRIC VISIBILITY

- Annex 2 VISIBILITY OF A RED LAMP TO THE FRONT AND VISIBILITY OF A WHITE LAMP TO THE REAR

- Annex 3 IDENTIFICATION OF SYMBOLS REGARDING MEASUREMENTS AND ANGLES OF GEOMETRIC VISIBILITY DESCRIBED IN THIS REGULATION

1. SCOPE AND PURPOSE

This global technical regulation specifies requirements for the location, geometric visibility and operation (electric connection) of lighting and light-signalling devices if they are installed on road vehicles.

The purpose of this regulation is to ensure the effectiveness, visibility (both in daylight and darkness or other condition of reduced visibility) and functioning of lighting and light-signalling devices in order to reduce the safety hazards caused by a) inadequate illumination of the roadway or glare caused by vehicle lighting devices; and b) confusion and diversion of the driver's attention from the driving task caused by miscomprehension of information from the vehicle's light-signalling devices as they relate to presence, identification and/or behaviour of the vehicle on the road.

2. APPLICATION

This regulation applies to road vehicles category 1 and 2 and their trailers 1/. This regulation does not apply to installation of additional lighting and light-signalling devices on public works vehicles.

3. DEFINITIONS

For the purpose of this regulation:

3.1. "Contracting Party" means a country or a regional economic integration, as prescribed by the AGREEMENT CONCERNING THE ESTABLISHING OF GLOBAL TECHNICAL REGULATIONS FOR WHEELED VEHICLES, EQUIPMENT AND PARTS WHICH CAN BE FITTED AND/OR BE USED ON WHEELED VEHICLES done at Geneva on 25 June 1998, that has adopted this regulation, and in whose jurisdiction the vehicle would be registered.

3.2. Vehicle characteristics

3.2.1. "Transverse plane" means a vertical plane perpendicular to the median longitudinal plane of the vehicle.

3.2.2. "Unladen vehicle" means a vehicle without driver, crew, passengers and load, but with a full supply of fuel, spare wheel and the tools normally carried.

1/ per "gtr 0" {the final text of "gtr 0" should be consulted and referred in the footnote once GRSG, WP.29 and AC.3 finish their deliberations.}

- 3.2.3. "Overall length" means the distance between two transverse planes touching the front-end and rear-end of the vehicle. All parts of the vehicle, including any original equipment parts projecting from the front or rear (towing-hooks, bumpers, etc.) are contained between these two planes.
- 3.2.4. "Extreme outer edge" on either side of the vehicle, means the plane parallel to the median longitudinal plane of the vehicle and touching its lateral outer edge, disregarding the projection:
- 3.2.4.1. of tyres near their point of contact with the ground, and of connections for tyre-pressure gauges;
- 3.2.4.2. of any anti-skid devices mounted on the wheels;
- 3.2.4.3. of rear-view mirrors;
- 3.2.4.4. of side direction indicator lamps, end-outline marker lamps, front and rear position lamps, parking lamps, retro-reflectors and side-marker lamps;
- 3.2.4.5. of Customs seals affixed to the vehicle, and of devices for securing and protecting such seals.
- 3.2.5. "Overall width" means the distance between the two opposite extreme outer edges of a vehicle.
- 3.2.6. "Operating tell-tale" means a visual or auditory signal (or any equivalent signal) indicating that a device has been switched on and is operating correctly or not.
- 3.2.7. "Circuit-closed tell-tale" means a visual (or any equivalent signal) indicating that a device has been switched on, but not indicating whether it is operating correctly or not.
- 3.2.8. "Ground" means a substantially horizontal surface on which the vehicle stands.
- 3.2.9. "Movable components" means those vehicle body panels or other vehicle parts the position(s) of which can be changed by tilting, rotating or sliding without the use of tools. They do not include tiltable driver cabs of trucks.
- 3.2.10. "Normal position of use of a movable component" means the position(s) of a movable component specified by the vehicle manufacturer for the normal condition of use and the park condition of the vehicle.
- 3.2.11. "Normal condition of use of a vehicle" means:

- 3.2.11.1. for a motor vehicle, when the vehicle is ready to move with its movable components in the normal position(s) of use and its propulsion system activated;
- 3.2.11.2. and for a trailer, when the trailer is connected to a drawing motor vehicle in the normal condition of use and the trailer's movable components are in the normal position(s) of use.
- 3.2.12. "Park condition of a vehicle" means:
 - 3.2.12.1. for a motor vehicle, when the vehicle is at standstill with its movable components in the normal position(s) of use and its propulsion system not activated;
 - 3.2.12.2. and for a trailer, when the trailer is connected to a drawing motor vehicle in the normal condition of use and the trailer's movable components are in the normal position(s) of use.
- 3.2.13. **"Light-duty vehicle" means passenger car, utility vehicle or light commercial vehicle not exceeding 6,000 mm in length, 2,032 mm in width, or [5,500] kilograms in gross vehicle weight.**
- 3.2.14. **"Heavy-duty vehicle" means on-road vehicles equal to or exceeding 6,000 mm in length, 2,032 mm in width, or [5,500] kilograms in gross vehicle weight. {Other suggestions are welcomed}**
- 3.2.15. "Front" means that part of the vehicle between the transverse vertical plane tangent to the extreme front-end including all original equipment components and the transverse vertical plane passing through the centre of the foremost axle.
- 3.2.16. "Rear" means that part of the vehicle between the transverse vertical plane tangent to the extreme rear-end including all original equipment components and the transverse vertical plane passing through the centre of the rearmost axle.
- 3.3. **LIGHTING AND LIGHT SIGNALLING DEVICES CHARACTERISTICS**
 - 3.3.1. "Device" means an element or an assembly of elements used to perform one or more functions.
 - 3.3.2. "Function"
 - 3.3.2.1. "Lighting function" means the light emitted by a device to illuminate the road and objects in the direction of vehicle movement, as defined in paragraphs 3.7.9., 3.7.10., 3.7.18., 3.7.20 and 3.7.27;
 - 3.3.2.2. "Light-signalling function" means the light emitted or reflected by a device to give to other road users visual information on the presence and/or the change of movement

of the vehicle, as defined in paragraphs 3.7.11. to 3.7.17. and paragraphs 3.7.19. to 3.7.26.

- 3.3.3. "Lamp" means a device designed to illuminate the road or to emit a light signal to other road users. Rear registration plate illuminating device and retro-reflectors are likewise to be regarded as lamps.
- 3.3.4. "Light source with regard to filament lamps" means the filament itself. In the case of a lamp having several filaments, each one shall constitute a light source.
- 3.3.5. "Objective luminous flux" means a design value of the luminous flux of a replaceable light source. It shall be achieved, within the specified tolerances, when the replaceable light source is energised by the power supply at the specified test voltage, as indicated in the data sheet of the light source.
- 3.3.6. "Independent lamps" means devices having separate illuminating surfaces 2/, separate light sources and separate lamp bodies.
- 3.3.7. "Grouped lamps" means devices having separate illuminating surfaces 2/ and separate light sources, but a common lamp body.
- 3.3.8. "Combined lamps" means devices having separate illuminating surfaces, 2/ but a common light source and a common lamp body.
- 3.3.9. "Reciprocally incorporated lamps" means devices having separate light sources or a single light source operating under different conditions (for example, optical, mechanical, electrical differences), totally or partially common illuminating surfaces 2/ and a common lamp body.
- 3.3.10. "Concealable lamp" means a lamp capable of being partly or completely hidden, when not in use. This result may be achieved by means of a movable cover, by displacement of the lamp or by any other suitable mean. The term "retractable" is used more particularly to describe a concealable lamp the displacement of which enables it to be inserted within the bodywork.
- 3.3.11. "Light emitting surface" of a lighting device light-signalling device or a retro-reflector means all or part of the exterior surface of the transparent material as defined by the manufacturer of the device (see annex 1).
- 3.3.12. "Illuminating surface" (see annex 1).

2/ In the case of lighting devices for the rear registration plate and the side direction indicators, replace by "light-emitting surface" in the absence of an illuminating surface.

- 3.3.12.1. "Illuminating surface of a lighting device" (paragraphs 3.4.1. to 3.4.5.) means the orthogonal projection of the full aperture of the reflector, or in the case of headlamps with an ellipsoidal reflector of the "projection lens" on a transverse plane. If the lighting device has no reflector, the definition of paragraph 3.3.12.2. shall be applied. If the light-emitting surface of the lamp extends over part only of the full aperture of the reflector, then the projection of that part only is taken into account.

In the case of a passing beam headlamp, the illuminating surface is limited by the apparent trace of the cut-off on to the lens. If the reflector and lens are adjustable relative to one another, the mean adjustment should be used.

- 3.3.12.2. "Illuminating surface of a light-signalling device other than a retro-reflector" (paragraphs 3.5.1. to 3.5.13. and 3.5.15. to 3.5.18.) means the orthogonal projection of the lamp in a plane perpendicular to its axis of reference and in contact with the exterior light-emitting surface of the lamp, this projection being bounded by the edges of screens situated in this plane, each allowing only 98 per cent of the total luminous intensity of the light to persist in the direction of the axis of reference.

To determine the lower, upper and lateral limits of the illuminating surface, only screens with horizontal or vertical edges shall be used.

- 3.3.12.3. "Illuminating surface of a retro-reflector" (paragraph 3.5.14.) means the orthogonal projection of a retro-reflector in a plane perpendicular to its axis of reference and delimited by planes contiguous to the outermost parts of the retro-reflector's optical system and parallel to that axis. For the purposes of determining the lower, upper and lateral edges of the device, only horizontal and vertical planes shall be considered.

- 3.3.13. "Apparent surface" for a defined direction of observation means, at the request of the manufacturer or his duly accredited representative, the orthogonal projection of either:

- the boundary of the illuminating surface projected on the exterior surface of the lens (a-b), or
- the light-emitting surface (c-d),

in a plane perpendicular to the direction of observation and tangential to the most exterior point of the lens (see annex 1 to this regulation).

- 3.3.14. "Axis of reference (reference axis)" means the characteristic axis of the lamp determined by the manufacturer (of the lamp) for use as the direction of reference ($H=0^\circ$, $V=0^\circ$) for angles of field for photometric measurements and for installing the lamp on the vehicle.

- 3.3.15. "Centre of reference" means the intersection of the axis of reference with the exterior light-emitting surface; it is specified by the manufacturer of the lamp.
- 3.3.16. "Angles of geometric visibility" means the angles, which determine the field of the minimum solid angle in which the apparent surface of the lamp must be visible. That field of the solid angle is determined by the segments of the sphere, the centre of which coincides with the centre of reference of the lamp, and the equator is parallel with the ground. These segments are determined in relation to the axis of reference. The horizontal angles β (beta) correspond to the longitude and the vertical angles α (alpha) to the latitude.
- 3.3.17. The following shall be deemed to be:
- 3.3.17.1. "**A single lamp**" means a device or part of a device having one lighting or light-signalling function, one or more light source(s) and one apparent surface in the direction of the reference axis, which may be a continuous surface or composed of two or more distinct parts as defined by an applicable regulations of a Contracting Party.
- 3.3.17.2. "Two lamps (an even number of lamps)", means a single light-emitting surface in the shape of a band or strip if such band or strip is placed symmetrically in relation to the median longitudinal plane of the vehicle, extends on both sides to within at least 400 mm of the adjacent extreme outer edge of the vehicle, and is not less than 0.8 m long; the illumination of such surface shall be provided by not less than two light sources placed as close as possible to its ends; the light-emitting surface may be constituted by a number of juxtaposed elements on condition that the projections of the several individual light-emitting surfaces on a transverse plane occupy not less than 60 per cent of the area of the smallest rectangle circumscribing the projections of the said individual light-emitting surfaces.

3.4. LIGHTING DEVICES

- 3.4.1. "Driving beam (main-beam, high-beam) headlamp" means a lamp used to illuminate the road over a long distance ahead of the vehicle.
- 3.4.2. "Passing beam (dipped-beam, low-beam) headlamp" means a lamp used to illuminate the road ahead of the vehicle without causing undue dazzle or discomfort to oncoming drivers and other road-users.
- 3.4.3. "Front fog lamp" means a lamp used to **illuminate or** improve the illumination of the road **ahead of the vehicle** in case of fog, snowfall, rainstorm or dust clouds.

3.4.4. "Cornering lamp" means a lamp used to provide supplementary illumination of that part of the road which is located near to the forward corner of the vehicle at the side towards which the vehicle is going to turn.

3.4.5. "Reversing lamp" means a lamp used to illuminate the road to the rear of the vehicle and to warn pedestrians and other road-users that the vehicle is reversing or is about to reverse.

3.5. LIGHT SIGNALLING DEVICES

3.5.5. "Direction indicator lamp" means a lamp used to indicate to other road-users that the driver intends to change direction to the right or to the left.

3.5.6. "Hazard warning signal" means the simultaneous operation of all of a vehicle's direction indicator lamps to show that the vehicle temporarily constitutes a special danger to other road-users.

3.5.7. "Stop lamp" means a lamp used to indicate to other road-users to the rear of the vehicle that the service brake is applied and/or longitudinal movement of the vehicle is intentionally retarded.

3.5.8. "Rear registration plate illuminating device" means a device used to illuminate the space reserved for the rear registration plate; such a device may consist of several optical components.

3.5.9. "Front position lamp" ("Parking lamp" in North America) means a lamp used to indicate the presence and the width of the vehicle when viewed from the front.

3.5.10. "Rear position lamp (tail lamp)" means a lamp used to indicate the presence and width of the vehicle when viewed from the rear.

3.5.11. "Rear fog lamp" means a lamp used to improve the visibility of a vehicle from the rear in case of fog, snowfall, rainstorms or dust clouds.

3.5.12. "Parking lamp" means a lamp, which is used to draw attention to the presence of a stationary vehicle.

3.5.13. "End-outline marker lamp (clearance lamp)" means a lamp fitted near to the extreme outer edge and as close as possible to the top of the vehicle and used to indicate clearly the vehicle's overall width. This lamp is intended, for certain vehicles and trailers, to complement the vehicles' front and rear position lamps.

3.5.14. "Retro-reflector" means a device used to indicate the presence **and parameters** of a vehicle by the reflection of light emanating from a light source not connected to the vehicle, the observer being situated near the source.

For the purposes of this regulation the following are not considered as retro-reflectors:

- 3.5.14.1. retro-reflecting registration plates;
- 3.5.14.2. the retro-reflecting signals mentioned in the ADR (European Agreement concerning the International Carriage of Dangerous Goods by Road);
- 3.5.14.3. other retro-reflecting plates and signals which must be used to comply with national requirements for use as regards certain categories of vehicles or certain methods of operation.
- 3.5.15. "Side-marker lamp" means a lamp used to indicate the presence of the vehicle when viewed from the side.
- 3.5.16. "Daytime running lamp" means a lamp facing in a forward direction used to make the vehicle more easily visible when driving during daytime.
- 3.5.17. "Identification lamps (ID lamps)" means a cluster of three lamps fitted at the top and about the centreline of a vehicle to draw particular attention to its bulk. These lamps are intended for certain vehicles and trailers, to complement the vehicle's front and rear position and end outline marker lamps.
- 3.5.18. "Conspicuity treatment" means a system of retro-reflective devices providing information regarding presence, width, length and bulk of a certain type of vehicles under condition of low or no ambient light.

4. GENERAL SPECIFICATIONS

- 4.1. **As installed on the vehicle**, any lighting and light-signalling device shall conform with all regulations **prescribed** for this device **by a Contracting Party**.
- 4.2. The lighting and light-signalling devices shall be so fitted that under normal conditions of use of the vehicle and notwithstanding any vibrations to which they may be subjected, they retain the characteristics prescribed by this regulation and enable the vehicle to comply with the requirements of this regulation. In particular, it shall not be possible for the lamps to be inadvertently maladjusted.
- 4.3. All lighting (road illumination) devices, except reversing and cornering lamps, shall be so installed that correct adjustment of their orientation can be carried out according to the instructions provided with the vehicle by the vehicle manufacturer without the use of special tools other than those provided with the vehicle by the

vehicle manufacturer. **The adjustment mechanism shall conform to the requirements prescribed to it by a Contracting Party.**

- 4.4. For all light-signalling devices, including those mounted on the side panels, the reference axis of the lamp when fitted to the vehicle must be parallel to the ground; in addition it must be perpendicular to the median longitudinal plane of the vehicle in the case of side retro-reflectors, and of side-marker lamps and parallel to that plane in the case of all other light-signalling devices. In each direction, a tolerance of $\pm 3^\circ$ shall be allowed. In addition, any specific instructions, laid down by the lamp manufacturer with regard to fitting of the light-signalling device on a vehicle, must be complied with.
- 4.5. In the absence of specific instructions, the height and orientation of the lamps shall be verified with the unladen vehicle under normal condition of use and placed on a ground.
- 4.6. In the absence of specific instructions, lamps of the same function, installed on the vehicle in an even number shall:
 - 4.6.1. be fitted to the vehicle symmetrically in relation to the median longitudinal plane (this estimate to be based on the exterior geometrical form of the lamp and not on the edge of its illuminating surface);
 - 4.6.2. be symmetrical to one another in relation to the median longitudinal plane, this requirement is not valid with regard to the interior structure of the lamp;
 - 4.6.3. satisfy the same colorimetric requirements; and
 - 4.6.4. have substantially identical photometric characteristics.
- 4.7. On vehicles whose external shape is asymmetrical, the above requirements shall be satisfied so far as possible.
- 4.8. **Grouped, combined or reciprocally incorporated lamps**
 - 4.8.1. **Except as specified in paragraphs 4.8.2. and 4.8.3., lamps may be grouped, combined or reciprocally incorporated with one another provided that all requirements regarding position, orientation, geometric visibility, electrical connections and other requirements, if any, of this regulation, as well as requirements regarding presence and colour of the function prescribed by a Contracting Party are fulfilled.**
 - 4.8.2. **Rear end outline marker lamp shall not be combined or reciprocally incorporated with a rear position lamp.**

- 4.8.3. A centre high mounted stop lamp shall be independent of any other lamp or retro-reflective device, except that it may be grouped with a lamp illuminating the cargo compartment.**
- 4.9. Measurements (see annex 3)
- 4.9.1. In height:
- “H1” – the maximum height above the ground shall be measured from the highest point; and
- “H2” – the minimum height from the lowest point of the apparent surface, in the direction of the reference axis.
- In the case of passing beam headlamp,
“H2” is measured from the lowest point of the effective outlet of the optical system (e.g. reflector, lens, projection lens) independent of its utilisation.
- 4.9.2. In width:
- “E” – the maximum distance of the lamp from the adjacent extreme outer edge of the vehicle shall be measured from that edge of the apparent surface in the direction of the reference axis which is the furthest from the median longitudinal plane of the vehicle.
- 4.9.3. In length:
- “K” – the maximum distance between the lamp and the transverse plane which marks the forward or rearward boundary of the vehicle's overall length (front-end or rear-end of the vehicle) shall be measured from that edge of the apparent surface in the direction of the reference axis which is the closest, respectively, to the front-end or rear-end of the vehicle.
- 4.9.4. Distance between two lamps:**
- “D” – the distance between two lamps, which face in the same direction, shall be measured between those edges of the two apparent surfaces of these two lamps in the direction of the reference axis, which are the closest to each other.**
- 4.9.5. Where the position, as regards maximum or minimum height, width, length, or distance between lamps, clearly meets the requirements of the regulation, the exact edges of any apparent surface need not be determined.

4.10. Visibility of red light to the front of a vehicle and of white light to the rear of a vehicle

Note: No account shall be taken of lighting devices fitted for the interior lighting of a vehicle.

4.10.1. For the visibility of red light towards the front of a vehicle, with the exception of a red rearmost side-marker lamp, there must be no direct visibility of the apparent surface of a red lamp if viewed by an observer moving within Zone 1 as specified in annex 2.

4.10.2. For the visibility of white light towards the rear of a vehicle, with the exception of the reversing lamp(s) **and the cornering lamp**, there must be no direct visibility of the apparent surface of a **white lamp capable of projecting or reflecting white light** if viewed by an observer moving within Zone 2 as specified in annex 2.

4.11. Electrical connections

4.11.1. The electrical connections must be such that the front and rear position lamps, the side-marker lamps, the rear registration plate illuminating device and the end-outline marker lamps, if they exist, can only be switched on and off simultaneously. This condition does not apply when using front and rear position lamps, as well as side-marker lamps when combined or reciprocally incorporated with said lamps, as parking lamps, and when side-marker lamps are permitted to flash.

4.11.2. The electrical connections must be such that driving beam and passing beam headlamps and the front fog lamps cannot be switched on unless the front and rear position lamps, the side-marker lamps, the rear registration plate illuminating device and the end-outline marker lamps, if they exist, are also switched on.

This requirement shall not apply, however, to driving beam or passing beam headlamps when their luminous warnings consist of the intermittent lighting up at short intervals of the driving beam headlamp or the intermittent lighting up at short intervals of the passing beam headlamp or the alternate lighting up at short intervals of the driving beam and passing beam headlamps **nor when the driving beam or passing beam headlamps are used at reduced intensity as daytime running lamps.**

4.11.3. **Unless otherwise specified in this regulation, lighting and light-signalling devices shall be steady burning when activated.**

4.11.4. In the absence of specific provision no lighting or light-signalling device shall be automatically operated.

4.12. Tell-tale

Where a "circuit-closed" tell-tale is prescribed by this regulation, it may be replaced by an "operating" tell-tale.

4.13. Concealable lamps

- 4.13.1. Lamps shall not be concealable with the exception of the driving beam headlamps, the passing beam headlamps and the front fog lamps, which may be concealed when they are not in use.
- 4.13.2. In the event of any failure affecting the operation of the concealment device(s) the lamps shall remain in the position of use, if already in use, or shall be capable of being moved into the position of use without the aid of tools.
- 4.13.3. It must be possible to move the lamps into the position of use and to switch them on by means of a single control, without excluding the possibility of moving them into the position of use, without switching them on. However, in the case of grouped driving beam and passing beam headlamps, the control referred to above is required only to activate the passing beam headlamps.
- 4.13.4. It must not be possible deliberately, from the driver's seat, to stop the movement of switched-on lamps before they reach the position of use. If there is a danger of dazzling other road users by the movement of the lamps, they shall light up only when they have reached their position of use.
- 4.13.5. When the concealment device has a temperature of $-30\text{ }^{\circ}\text{C}$ to $+50\text{ }^{\circ}\text{C}$ the headlamps must be capable of reaching the position of use within three seconds of initial operation of the control.

4.14. Number of lamps

If lamps or retro-reflective devices described by this regulation are required or allowed by a Contracting Party to be installed on a vehicle, their number shall be equal to the number(s) specified in paragraphs 5.1. to 5.22.

4.15. Lighting devices installed on, or covered by, movable components:

- 4.15.1. Rear position lamps, all direction indicators except side direction indicators and all mandatory retro- reflectors must not be installed on movable components unless at all fixed positions of the movable components the lamps on the movable components meet all the **location and geometric visibility** requirements for those lamps, or a device meeting all requirements for those lamps is installed.

- 4.15.2. There must not be any movable component, with or without a light-signalling device installed on it, which in any fixed position hides more than 50 per cent of the apparent surface of front and rear position lamps, front and rear direction indicator lamps, side-marker lamps or any retro-reflector when viewed in the reference axis of this specific device. If this is not practicable:
- 4.15.2.1. an alternative device meeting all requirements for those lamps may be installed; or
- 4.15.2.2. a notice in the vehicle shall inform the user that in certain position(s) of the movable components other road users shall be warned of the presence of the vehicle on the road by means provided by the manufacturer with the vehicle.
- 4.15.3. No road illumination device (driving beam headlamp, passing beam headlamp, front fog lamp, etc) shall be mounted on movable component whose movement causes the beam pattern of the device to move upwards, unless the device mounted on such movable component will be automatically switched off while the movable component is moved out of its normal position of use specified for a vehicle being in the normal condition of use.
- 4.15.4. When a lamp is installed on a movable component and the movable component is in the normal position(s) of use, the lamp must always return to the position(s) specified by the manufacturer in accordance with this regulation. In the case of passing beam headlamps and front fog lamps, this requirement shall be considered satisfied if, when the movable components are moved and returned to the normal position 10 times, no value of the angular inclination of these lamps, relative to its support, measured after each operation of the movable component, differs by more than 0.15 per cent from the average of the 10 measured values.
- 4.15.5. If equipment mounted on a vehicle (e.g. mirrors, snowploughs wrecker booms, backhoes, winches, etc.) obstructs the performance of a required by a Contracting Party lamp or retro-reflecting device, a lamp or retro-reflecting device, meeting all requirements of the obstructed device shall be installed.**
- 4.16. No lamp, required by a Contracting Party, shall be installed on a vehicle component that can be removed from the vehicle without rendering the vehicle inoperable or illegal to be operated.**
- 4.17. The presence of partitions or other items of equipment on the vehicle shall not give rise to reflections causing discomfort glare to other road users.**
- 4.18. Lamps shall be fitted in a vehicle in such a way that the light source can be correctly replaced according to the instructions provided with the vehicle by the vehicle manufacturer without the use of special tools other than those provided with the vehicle by the vehicle manufacturer. This requirement is not applicable to devices equipped with a non-replaceable light source.

- 4.19. **Lighting and light signalling devices shall be marked in accordance with the laws and regulations of a Contracting Party.**
- 4.20. **Lamps not described in this regulation may be installed on a vehicle on condition that they do not interfere with any lamp or retro-reflecting device required or allowed by a Contracting Party and that they do not cause discomfort glare to road users.**
- 4.21. With the exception of retro-reflectors, a lamp ~~even bearing an approval mark~~ is deemed not to be present when it cannot be made to operate by the sole installation of a light source.
- 4.22. Any temporary fail-safe substitution of **any** light-signalling function ~~of a rear position lamp~~ is allowed, provided that the substituting function is identical in colour, main intensity and position to the function that has ceased to operate and provided that the substituting device remains operational in its original safety function. During substitution **for the rear position lamp**, a tell-tale shall indicate occurrence of a temporary substitution and need for repair.
- 4.23. Geometric visibility
- 4.23.1. There must be no obstacle on the inside of the angles of geometric visibility, as described in paragraph 3.3.16., to the propagation of light from any part of the apparent surface of the lamp observed from infinity; **however, no account is taken of obstacles, if they were already present when the lamp was photometrically tested.**
- 4.23.2. If measurements are taken closer to the lamp, the direction of observation must be shifted parallel to achieve the same accuracy.
- ~~On the inside of the angles of geometric visibility, no account is taken of obstacles, if they were already present when the lamp was photometrically tested.~~
- 4.23.3. If, when the lamp is installed, any part of the apparent surface of the lamp is hidden by any ~~further~~ parts of the vehicle, the part of the lamp not hidden by obstacles must still conform to the photometric values prescribed for the device.
- 4.23.4. When the vertical angle of geometric visibility below the horizontal may be reduced to 5° (lamp at less than 750 mm above the ground) the photometric field of measurements of the installed optical unit may be reduced to 5° below the horizontal.

5. INDIVIDUAL SPECIFICATIONS

5.1. DRIVING BEAM HEADLAMP

5.1.1. **Functional purpose**

Lamps intended to provide primarily distant forward illumination for a vehicle other than trailer under normal condition of use; primarily for use outside of the urban area and when not meeting or following other vehicles.

5.1.2. Number

Two or four

5.1.3. Arrangement:

No point on the apparent surface in the direction of the reference axis of the driving beam headlamp shall be further outboard than any point on the apparent surface in the direction of reference axis of the passing beam headlamp, which is closest to the adjacent extreme outer edge of the vehicle.

Fitted in such a way that the light emitted does not cause discomfort glare to the driver either directly or indirectly through the rear-view mirrors and/or other reflecting surfaces of the vehicle.

5.1.4. Position

5.1.4.1. In width: no individual specifications.

5.1.4.2. In height: no individual specifications.

5.1.4.3. In length: no individual specifications.

5.1.5. Geometric visibility

The visibility of the illuminating surface, including its visibility in areas which do not appear to be illuminated in the direction of observation considered, must be ensured within a divergent space defined by generating lines based on the perimeter of the illuminating surface and forming an angle of not less than 5° with the axis of reference of the headlamp.

The origin of the angles of geometric visibility is the perimeter of the projection of the illuminating surface on a transverse plane tangent to the foremost part of the lens of the headlamp.

5.1.6. Orientation

Towards the front.

5.1.7. Electrical connections

5.1.7.1. The driving beam headlamps may be switched on only when the master light switch is in the "headlamps-on" position except when they are used to provide light signals consisting of intermittent illumination at short intervals.

5.1.7.2. If there are two pairs of the driving beam headlamps they shall be switched on in pairs. For changing over from the passing to the driving beam only the first pair of driving beam headlamps shall be switched on. For changing over from the driving beam to the passing beam all driving beam headlamps shall be switched off simultaneously and the second pair shall then remain off until deliberately switched on again.

5.1.7.3. If there are two pairs of driving beam headlamps, the passing beams may remain switched on at the same time as one pair of driving beams.

5.1.7.4. Where four concealable headlamps are fitted their raised position must prevent the simultaneous operation of any additional headlamps fitted, if these are intended to provide light signals consisting of intermittent illumination at short intervals in daylight.

5.1.7.5. Automatic switching from driving beam to passing beam mode is allowed.

5.1.8. Tell-tale

Circuit-closed tell-tale mandatory.

5.1.9. Other provisions

5.1.9.1. Driving beam headlamp and/or its beam pattern may swivel about a substantially vertical axis in accordance to the direction of the vehicle travel.

5.1.9.2. Where a vehicle is fitted with four concealable driving beam headlamps the installation of two more headlamps shall be allowed only for the purpose of providing light-signalling, consisting of intermittent illumination, at short intervals in the daylight.

5.1.9.3. The aggregate maximum intensity of all driving beam headlamps shall conform with the requirements of a Contracting Party.

5.2. PASSING BEAM HEADLAMP

5.2.1. **Functional purpose**

Lamps intended to provide illumination of the road ahead of the vehicle other than trailer under normal condition of use without causing undue discomfort to oncoming drivers and other road users. Primarily for use in urban areas and when meeting or following another vehicle.

5.2.2. Number

Two.

5.2.3. Arrangement

Fitted in such a way that the light emitted does not cause discomfort glare to the driver either directly or indirectly through the rear-view mirrors and/or other reflecting surfaces of the vehicle.

5.2.4. Position (see annex 3)

5.2.4.1. In width:

E less or equal to 400 mm;

5.2.4.2. In height:

H2 more or equal to 500 mm; and

Light duty vehicles and vehicles equipped with headlamps whose light sources have an objective luminous flux exceeding 2,000 lumen each

H2 less or equal to 950 mm.

Heavy-duty vehicles:

H2 less or equal to 1,200 mm.

5.2.4.3. In length:

at the front of the vehicle.

5.2.5. Geometric visibility (see annex 3)

Horizontal angles:

β_1 equal to 45° and
 β_2 equal to 10° .

Vertical angles:

α_1 equal to 15° and
 α_2 equal to 10° ,

5.2.6. Orientation

5.2.6.1. Towards the front.

5.2.6.2. **Each Contracting Party may prescribe specific initial vertical and/or horizontal orientation of the passing beam cut-off and/or other characteristic of the projected pattern.**

5.2.6.3. Each Contracting Party may prescribe specific provisions regarding manual or automatic levelling devices for passing beam headlamps.

5.2.7. Electrical connections

The control for changing over to the passing beam must switch off all driving beam headlamps simultaneously.

The passing beams may remain switched on at the same time as one pair of driving beams.

Passing beam headlamps equipped with gas-discharge light sources shall remain switched on during the driving beam operation.

~~One additional light source, located inside the passing beam headlamps or in a lamp (except the driving beam headlamp) grouped or reciprocally incorporated with the respective passing beam headlamps, may be activated to produce bend lighting, provided that the horizontal radius of curvature of the trajectory of the centre of gravity of the vehicle is 500 m or less. This may be demonstrated by the manufacturer by calculation or by other means accepted by the Contracting Party.~~

Passing-beam headlamps may be switched ON or OFF automatically.

Each Contracting Party may require that it shall always be possible to switch the passing-beam headlamps ON and OFF manually.

5.2.8. Tell-tale

Tell-tale optional.

5.2.9. Other provisions

The requirements of paragraph 4.6.2. shall not apply to passing beam headlamps.

Passing beam headlamp and/or its beam pattern may swivel about a substantially vertical axis according to the direction of the vehicle travel.

Passing beam headlamps with a light sources having combined objective luminous flux, which exceeds 2,000 lumen shall only be installed in conjunction with the installation of headlamp cleaning device(s) **and automatic levelling device maintaining vertical inclination of the headlamp under different vehicle loading conditions.**

Mechanical headlamp cleaning devices (wipers) shall not be installed on headlamps with plastic lenses.

5.3. FRONT FOG LAMP^{3/}

5.3.1. Functional Purpose

Lamps **installed on vehicles other than trailers and** intended to provide or enhance forward visibility under limited ambient light condition in case of fog, rain, dust clouds and snow.

5.3.2. Number

Two.

5.3.3. Arrangement

No point on the apparent surface in the direction of the reference axis may be higher than the highest point on the apparent surface in the direction of the reference axis of the passing beam headlamp.

5.3.4. Position

5.3.4.1. In width:

^{3/} Applies only if this device is regulated by a Contracting Party.

E less or equal to 400 mm

5.3.4.2. In height:

H1 more or equal to 250 mm

H2 less or equal to 800 mm

5.3.4.3. In length:

at the front of the vehicle and fitted in such a way that the light emitted does not cause discomfort glare to the driver either directly or indirectly through the rear-view mirrors and/or other reflecting surfaces of the vehicle.

5.3.5. Geometric visibility

Horizontal angles:

β_1 equal to 45°

β_2 equal to 10°

Vertical angles:

α_1 equal to 5°

α_2 equal to 5°

5.3.6. Orientation

Towards the front.

They must be directed forward without causing undue dazzle or discomfort glare to oncoming drivers and other road users.

5.3.7. Electrical connections

Shall be such that:

5.3.7.1. The front fog lamps may be switched on and off independently of driving and/or passing beam headlamps.

5.3.7.2. The front fog lamps may continue to operate until the position lamps are switched off, and the front fog lamps shall then remain off until deliberately switched on again.

5.3.8. Tell-tale

Circuit-closed tell-tale mandatory. An independent non-flashing warning light.

5.3.9. Other provisions

None.

5.4. REVERSING LAMP

5.4.1. **Functional Purpose**

Lamp(s) intended to provide illumination behind the vehicle and a warning signal to pedestrians and other drivers when the vehicle's transmission is placed in reverse.

5.4.2. Number

One or two.

5.4.3. Arrangement

No special requirement.

5.4.4. Position

5.4.4.1. In width:

no special requirement.

5.4.4.2. In height:

H1 more or equal to 250 mm

H2 less or equal to 1,200 mm

5.4.4.3. In length:

at the **back** of the vehicle.

5.4.5. Geometric visibility

5.4.5.1. Horizontal angles:

If one lamp:

β_1 equal to 45°

β_2 equal to 45°

If two lamps:

β_1 equal to 45°

β_2 equal to 30°

Vertical angles:

α_1 equal to 15°

α_2 equal to 5°

5.4.5.2. In case of reversing lamps installed in accordance with paragraph 5.4.9.:

Horizontal angles:

if only one lamp

β_1 equal to 45°

β_2 equal to 45°

if two lamps

β_1 equal to 45°

β_2 equal to 10°

Vertical angles:

α_1 equal to 5°

α_2 equal to 5°

5.4.6. Orientation

Rearwards.

5.4.7. Electrical connection

5.4.7.1. Electrical connections shall be such that the lamp can light up only if the reverse gear is engaged and if the device which controls the starting and stopping of the engine is in such a position that operation of the engine is possible. It shall not light up or remain lit if either of the above conditions is not satisfied.

5.4.7.2. When reversing lamp(s) installed in accordance with 5.4.9. it (they) shall be switched on and off separately from the mandatory lamp(s), while at the same time the conditions of paragraph 5.4.7.1. remain satisfied. When one of the conditions of paragraph 5.4.7.1. is no longer satisfied, the lamp(s) shall be switched off, and remain off until the conditions of paragraph 5.4.7.1. are fulfilled and the lamp(s) are deliberately switched on again.

5.4.8. Tell-tale

Tell-tale optional.

5.4.9. Other provisions

One or two optional reversing lamps may be fitted on all motor vehicles over 6,000 mm in length and all trailers.

5.5. DIRECTION INDICATOR LAMP

5.5.1. Functional Purpose

Flashing lamps intended to indicate the intention of the operator of a vehicle to change direction or change lanes by giving a flashing signal on the side toward which the turn or manoeuvre will be made.

5.5.2. Number

Motor vehicle:

2 front direction indicator lamps

2 rear direction indicator lamps

2 optional rear direction indicator lamps

2 side direction indicator lamps 3/

2 middle-side direction indicators 3/ on vehicles exceeding 9 m in length.

Trailer:

2 side direction indicator lamps 3/ for trailers of 6,000 mm or more in overall length,

2 rear direction indicator lamps

2 optional rear direction indicator lamps.

5.5.3. Arrangement

- 5.5.3.1. Where lamps combining the functions of front direction indicator lamps and side direction indicator lamps are fitted, in addition two side direction indicator lamps may be installed to meet the visibility requirements of paragraph 5.5.5.
- 5.5.3.2. If the distance between the edge of the apparent surface in the direction of the reference axis or the optical centre of the direction indicator lamp and that of the apparent surface in the direction of the reference axis of the passing-beam headlamp and/or the front fog lamp is less than respectively 40 mm or 100 mm the photometric output of the direction indicator must be increased according to the regulation of a Contracting Party.
- 5.5.4. Position (see annex 3)
- 5.5.4.1. In width (front and all rear):
- E less or equal to 400 mm
- D more or equal to 600 mm
- vehicles less than 1,300 mm wide
- D more or equal to 400 mm
- 5.5.4.2. In height (all):
- H2 more or equal to 350 mm
- H1 less or equal to 1,500 mm
- If the structure of the vehicle does not permit the upper limit to be respected, and if the optional lamps are not installed,
- H1 less or equal to 2,100 mm.
- If optional rear direction indicator lamps are installed, they shall be placed at a height compatible with the applicable requirements of paragraph 5.5.4.1. and the symmetry of the lamps, and at a vertical distance as large as the shape of the bodywork makes it possible, but not less than 600 mm, above the mandatory direction indicator lamps.
- 5.5.4.3. In length:
- Front direction indicator lamps:
- at the front.

Side direction indicator lamps 3/ on motor vehicles:

K less or equal to the lesser of 2,500 mm, or half of the vehicle's overall length, measured from the front of the vehicle.

Side direction indicator lamps 3/ on trailers:

the side direction indicator lamp shall be in the middle third of the vehicle

Middle-side direction indicator lamps 3/:

Rear direction indicator lamps:

at the rear.

5.5.5. Geometric visibility (see annex 3)

5.5.5.1. Horizontal angles:

Front direction indicators:

β_1 equal to 80°

β_1 equal to 45° when direction indicator is supplemented by flashing front side-marker lamp.

β_2 equal to 45°

Rear direction indicator:

Motor vehicles:

β_1 equal to 80°

β_1 equal to 45° when direction indicator is supplemented by flashing rear amber side-marker lamp.

β_2 equal to 45°

Trailer:

β_1 equal to 80°

β_2 equal to 45°

Side direction indicator 3/:

β_3 equal to 60°

η equal to 5°

(angles β_3 and η are measured from the plane tangent to the lens of the side turn signal lamp and parallel to the longitudinal plane of the vehicle)

5.5.5.2. Vertical angles:

α_1 equal to 15° (5° if H1 of the optional direction indicator lamps is more than 2,100 mm)

α_2 equal to 15° (5° if H1 is less than 750mm)

side direction indicator lamps 3/:

α_1 equal to 30°

α_2 equal to 5°

5.5.5.3. For the direction indicator to be considered visible throughout the angles of geometric visibility one of the following shall be met:

The minimum luminous intensity within the above angles must not be less than 0.3 cd;

or

Throughout the angles of geometric visibility, with the outward angle up to 45° , the lamp must provide an unobstructed view of the apparent surface of at least 12.5 cm^2 , except for the side direction indicator 3/ for which the minimum area is 10 cm^2 . The apparent surface of any retro-reflector shall be excluded.

5.5.6. Orientation

According to the specifications for installation by the manufacturer, if any.

5.5.7. Electrical connections

Direction indicator lamps shall switch on independently of the other lamps.

All direction indicator lamps on one side of a vehicle shall be switched on and off by means of one control and shall flash in phase.

The amber side-marker lamps, if they flash, shall also flash at the same frequency [and in phase] with the direction indicator lamps.

All direction indicator lamps may also flash simultaneously in association with vehicle alarm systems and/or immobilisers to draw attention to the vehicle and/or during the arming and disarming of the vehicle's alarm system.

5.5.8. Tell-tale

Operating tell-tale mandatory for front and rear direction indicator lamps. It may be visual or auditory or both. If it is visual it shall be a flashing light which, at least in the event of the malfunction of any of the front or rear direction indicator lamps, is either extinguished, or remains alight without flashing, or shows a marked change of frequency. If it is auditory only, it shall be clearly audible and shall show a marked change of frequency, at least in the event of the malfunction of any of the front or rear direction indicator lamps.

If a motor vehicle is equipped to draw a trailer, it must be fitted with a special visual operational tell-tale for the direction indicator lamps on the trailer unless the tell-tale of the drawing vehicle allows the failure of any one of the direction indicator lamps on the vehicle combination thus formed to be detected.

For the optional pair of rear direction indicator lamps on trailers, operating tell-tale shall not be mandatory.

5.5.9. Other provisions

The direction indicator shall emit light at a steady rate of 90 ± 30 flashes per minute.

Operation of the light-signal control shall be followed within not more than one second by the emission of light and within not more than one and one-half seconds by its first extinction.

If a motor vehicle is equipped to draw a trailer, the control of the direction indicator lamps on the drawing vehicle shall also operate the direction indicator lamps of the trailer.

In case of failure, other than short-circuit, of one direction indicator lamp, the others must continue to flash, but the frequency in this condition may be different from that prescribed.

Rear direction indicator lamps must not be reciprocally incorporated with stop lamps.

5.6. HAZARD WARNING SIGNAL

5.6.1. Functional Purpose

Flashing lamps intended to be used as the hazard warning system when all turn signal lamps on the vehicle are activated and flash simultaneously to indicate to other drivers the presence of a vehicular hazard.

5.6.2. Number

As specified in paragraph 5.5.2.

5.6.3. Arrangement

As specified in paragraph 5.5.3.

5.6.4. Position

5.6.4.1. In width:

As specified in paragraph 5.5.4.1.

5.6.4.2. In height:

As specified in paragraph 5.5.4.2.

5.6.4.3. In length:

As specified in paragraph 5.5.4.3.

5.6.5. Geometric visibility

As specified in paragraph 5.5.5.

5.6.6. Orientation

As specified in paragraph 5.5.6.

5.6.7. Electrical connections

The signal shall be operated by means of a separate control enabling all direction indicators and, if used, side marker lamps to flash in accordance with the requirements of paragraph 5.5. above.

5.6.8. Tell-tale

Circuit-closed tell-tale mandatory. Flashing warning light, which can operate in conjunction with the tell-tale(s) specified in paragraph 5.5.8.

5.6.9. Other provisions

As specified in paragraph 5.5.9. If a power-driven vehicle is equipped to draw a trailer the hazard warning signal control shall also be capable of bringing the direction indicator **and, if used, side marker** lamps on the trailer into action. The hazard warning signal shall be able to function even if the device which starts or stops the propulsion system of the vehicle is in a position which makes it impossible to start the propulsion system.

5.7. STOP LAMP

5.7.1. **Functional Purpose**

Lamps, which give a steady burning warning light to the rear of the vehicle, are intended to indicate to the following traffic that the vehicle is about to stop or is diminishing its speed.

5.7.2. Number

light duty motor vehicles: 3

other motor vehicles and trailers: 2, 3 or 4 (see arrangement)

5.7.3. Arrangement

All vehicles:

one pair of stop lamps

light-duty vehicles (optional on other vehicles):

In addition to the pair of stop lamps, one centre stop lamp mounted on the centreline of the vehicle.

Only, when the median longitudinal plane of the vehicle is not located on a fixed body panel but separates one or two movable parts of the vehicle (e.g. doors), and lacks sufficient space to install a single centre stop lamp on the median longitudinal plane above or below such movable parts, either:

Centre stop lamp composed of two devices may be installed, one on each movable part, or

one centre stop lamp may be installed offset to the left or to the right of the median longitudinal plane.

In addition on other motor vehicles and trailers:

one optional pair of stop lamps may be installed if centre stop lamp is not installed.

5.7.4. Position

5.7.4.1. In width:

For each lamp of the pair of stop lamps:

E less or equal to 400 mm;

For centre stop lamp:

the centre of reference shall be situated on the median longitudinal plane of the vehicle.

However, in the case where a centre stop lamp composed of two devices is installed, according to paragraph 5.7.3., they shall be positioned as close as possible to the median longitudinal plane, one on each side of this plane.

In the cases where one centre stop lamp offset from the median longitudinal plane is permitted according to paragraph 5.7.2., this offset shall not exceed 150 mm from the median longitudinal plane to the centre of reference of the lamp.

5.7.4.2. In height:

For the pair of stop lamps:

H2 more or equal to 350 mm (380 mm to the optical centre of the lamp)

H1 less or equal to 1,500 mm (2,100 mm if the shape of the bodywork makes it impossible to keep within 1,500 mm and if the optional lamps are not installed. If the optional lamps are installed, they shall be positioned at a height compatible with the requirements of the width and the symmetry of the lamps, and at the vertical distance as large as the shape of the bodywork makes it possible, but not less than 600 mm above the mandatory lamps).

For centre stop lamp the horizontal plane tangential to the lower edge of the apparent surface shall be:

not more than 150 mm below the horizontal plane tangential to the lower edge of the exposed surface of the glass or glazing of the rear window, or

H2 more or equal to 850 mm

However, the horizontal plane tangential to the lower edge of the apparent surface of centre stop lamp shall be above the horizontal plane tangential to the upper edge of the apparent surface of the symmetrical pair of stop lamps.

5.7.4.3. In length:

For a pair of stop lamps:

at the rear of the vehicle.

For centre stop lamp:

no special requirement.

5.7.5. Geometric visibility

Horizontal angles:

For a pair of stop lamps:

β_1 equal to 45°

β_2 equal to 45°

For centre stop lamp:

10° to the left and to the right of the longitudinal axis of the vehicle;

Vertical angles:

For the pair of stop lamps:

α_1 equal to 15° (5° if H1 of the optional stop lamps is more than 2,100 mm)

α_2 equal to 15° (5° if H1 is less than 750 mm)

For centre stop lamp:

α_1 equal to 10°

α_2 equal to 5°

5.7.6. Orientation

Towards the rear of the vehicle.

5.7.7. Electrical connections

All stop lamps must light up simultaneously when either the service brake or endurance brake (e.g. retarder) is activated. They must also light up when a complete or partial braking system is activated for the purpose of generating vehicle speed retardation with or without a direct action of the driver.

The stop lamps need not function if the device, which starts and/or stops the engine, is in a position that makes it impossible for the engine to operate."

5.7.8. Tell-tale

Tell-tale optional; where fitted, this tell-tale must be an operating tell-tale consisting of a non-flashing warning light which comes on in the event of the malfunctioning of the stop lamps.

5.7.9. Other provisions

5.7.9.1. The centre stop lamp may be installed outside or inside the vehicle.

5.7.9.2. In the case where it is installed inside the vehicle:

the light emitted shall not cause discomfort glare to the driver through the rear-view mirrors and/or other surfaces of the vehicle (i.e. rear window); and

the photometric requirements of the centre stop lamp must be met with the glazing behind which the lamp is to be installed.

5.7.9.3. Any stop lamp must not be reciprocally incorporated with rear direction indicator lamp.

5.8. REAR REGISTRATION PLATE ILLUMINATING DEVICE

5.8.1. Functional Purpose

Device intended to illuminate the license plate on the rear of a vehicle.

5.8.2. Number

Such that the device illuminates the site of the registration plate.

5.8.3. Arrangement

Such that the device illuminates the site of the registration plate.

5.8.4. Position

5.8.4.1. In width:

such that the device illuminates the site of the registration plate.

5.8.4.2. In height:

such that the device illuminates the site of the registration plate.

5.8.4.3. In length:

such that the device illuminates the site of the registration plate.

5.8.5. Geometric visibility

Such that the device illuminates the site of the registration plate.

5.8.6. Orientation

Such that the device illuminates the site of the registration plate.

5.8.7. Electrical connections

In accordance with paragraph 4.11.

5.8.8. Tell-tale

Tell-tale optional. If it exists, its function must be carried out by the tell-tale required for the front and rear position lamps.

5.8.9. Other provisions

When the rear registration plate illuminating device is combined with the rear position lamp, reciprocally incorporated in the stop lamp or in the rear fog lamp, the photometric characteristics of the rear registration plate illuminating device may be modified during the illumination of the stop lamp or the rear fog lamp.

5.9. FRONT POSITION LAMP

5.9.1. Functional Purpose

Lamps intended to mark the vehicle under normal conditions of use when temporarily parked in an area where use of the headlamps or hazard warning lamps is not warranted. In addition, these front lamps serve to indicate the vehicle width in the event of passing beam headlamp failure.

5.9.2. Number

Two.

5.9.3. Arrangement

No special requirement.

5.9.4. Position

5.9.4.1. In width:

as close as practicable to the adjacent extreme edge of the vehicle while:

motor vehicles:

E less or equal to 400 mm

trailers:

E less or equal to 150 mm.

5.9.4.2. In height:

H2 more or equal to 350 mm (380 mm from the optical centre of the lamp)

H1 less or equal to 1,500 mm (2,100 mm if the shape of the bodywork makes it impossible to keep within 1,500 mm)

5.9.4.3. In length:

no individual specification.

5.9.4.4. Where the front position lamp and another lamp are reciprocally incorporated, the apparent surface in the direction of the reference axis of the other lamp must be used to verify compliance with the positioning requirements (paragraphs 5.9.4.1. to 5.9.4.3.).

5.9.5. Geometric visibility

5.9.5.1. Horizontal angles:

β_1 equal to 45°

β_2 equal to 45°

Vertical angles:

α_1 equal to 15°

α_2 equal to 15° (5° if H1 less than 750 mm)

- 5.9.5.2. For the front position lamp to be considered visible throughout the angles of geometric visibility the following shall be met:

The minimum luminous intensity within the above angles must not be less than 0.05 cd;

or

The lamp must provide an unobstructed view of the projected apparent surface of at least 12.5 cm^2 .

The illuminating surface area of any retro-reflector that does not transmit light shall be excluded.

- 5.9.6. Orientation

Forwards.

- 5.9.7. Electrical connections

In accordance with paragraph 4.11.

- 5.9.8. Tell-tale

Circuit-closed tell-tale mandatory. This tell-tale shall be non-flashing and shall not be required if the instrument panel lighting can only be turned on simultaneously with the front position lamps.

- 5.9.9. Other provisions

None.

- 5.10. REAR POSITION LAMP

- 5.10.1. Functional Purpose**

Lamps intended to designate the rear of a vehicle. When viewed from the rear, they indicate the presence and width of a vehicle.

5.10.2. Number

Two.
[Two optional. See 5.10.4.2.]

5.10.3. Arrangement

No special requirement.

5.10.4. Position

5.10.4.1. In width:

as close as practicable to the adjacent extreme edge of the vehicle while:

**E less or equal to 400 mm
[this condition shall not apply to the optional rear position lamps]**

5.10.4.2. In height:

H2 more or equal to 350 mm (380 mm from the optical centre of the lamp)

H1 less or equal to 1,500 mm (2,100 mm if the shape of the bodywork makes it impossible to keep within 1,500 mm and if the optional lamps are not installed.

[If the optional lamps are installed, they shall be placed at a height compatible with the applicable requirements of paragraph 5.10.4.1., the symmetry of the lamps, and at a vertical distance as large as the shape of the bodywork makes it possible, but not less than 600 mm above the mandatory lamps.]

5.10.4.3. In length:

at the rear of the vehicle.

5.10.5. Geometric visibility

5.10.5.1. Horizontal angles:

β_1 equal to 45°
 β_2 equal to 45°

Vertical angles:

α_1 equal to 15° (5° if H1 of the optional rear position lamps more 2,100 mm)

α_2 equal to 15° (5° if H1 less than 750 mm)

- 5.10.5.2. For the rear position lamp to be considered visible throughout the angles of geometric visibility the following shall be met:

The minimum luminous intensity within the above angles must not be less than 0.05 cd;

or

The lamp must provide an unobstructed view of the projected apparent surface of at least 12.5 cm^2 .

The illuminating surface area of any retro-reflector that does not transmit light shall be excluded.

- 5.10.6. Orientation

Rearwards.

- 5.10.7. Electrical connections

In accordance with paragraph 4.11.

- 5.10.8. Tell-tale

Circuit-closed tell-tale mandatory. It must be combined with that of the front position lamps.

- 5.10.9. Other provisions

Except in the case where end-outline marker lamps are installed, two optional position lamps may be installed on all vehicles other than light-duty vehicles.

- 5.11. REAR FOG LAMP 3/

- 5.11.1. Functional Purpose

Lamp(s) intended to provide light of higher intensity than a rear position lamp for the purpose of marking the rear of a vehicle during fog or similar conditions of reduced visibility.

- 5.11.2. Number

One or two.

5.11.3. Arrangement

No special requirement.

5.11.4. Position

5.11.4.1. In width:

two lamps:

no specific requirements

one lamp:

it must be on the opposite side of the median longitudinal plane of the vehicle to the direction of traffic prescribed in the country of registration, the centre of reference may also be situated on the median longitudinal plane of the vehicle.

5.11.4.2. In height:

H2 more or equal to 250 mm

H1 less or equal to 1,000 mm.

5.11.4.3. In length:

at the rear of the vehicle.

5.11.5. Geometric visibility

Horizontal angles:

β_1 equal to 25°

β_2 equal to 25°

Vertical angles:

α_1 equal to 5°

α_2 equal to 5°

5.11.6. Orientation

Rearwards.

5.11.7. Electrical connections

These must be such that:

5.11.7.1. The rear fog lamp(s) cannot be switched on unless the driving beams, passing beams or front fog lamps are lit;

5.11.7.2. The rear fog lamp(s) can be switched off independently of any other lamp;

5.11.7.3. If not switched off manually, the rear fog lamp(s) may continue to operate until the position lamps are switched off. The rear fog lamp(s) shall then remain off until deliberately switched on again.

5.11.7.4 Except as provided in paragraphs 5.11.7.1. and 5.11.7.3., the operation of the rear fog lamp(s) shall not be affected by switching on or off any other lamps.

5.11.8. Tell-tale

Circuit-closed tell-tale mandatory. An independent non-flashing warning light.

5.11.9. Other provisions

In all cases, the distance between the rear fog lamp and each stop-lamp must be greater than 100 mm.

5.12. PARKING LAMP ^{3/}

5.12.1. Functional purpose

Light duty vehicle lamps intended to provide low level light to draw attention to the presence of parked vehicle under dark ambient conditions.

5.12.2. Number

According to the arrangement.

5.12.3. Arrangement

Four lamps: two lamps at the front and two lamps at the rear,
or
Two lamps: one lamp on each side.

5.12.4. Position

5.12.4.1. In width:

E less or equal to 400 mm.

If there are two lamps, they shall be on the sides of the vehicle.

5.12.4.2. In height:

no special requirement;

5.12.4.3. In length:

no special requirement.

5.12.5. Geometric visibility

Horizontal angles:

For lamps mounted on the front and rear of the vehicle:

β_1 equal to 45°

For lamps mounted on the side of the vehicle:

β_1 equal to 45°

β_2 equal to 45°

Vertical angles:

α_1 equal to 15°

α_2 equal to 15° (5° if H1 less than 750 mm)

5.12.6. Orientation

Such that the lamps meet the requirements for visibility forwards and rearwards.

5.12.7. Electrical connections

The connection must allow the parking lamp(s) on the same side of the vehicle to be lit independently of any other lamps. The parking lamp(s) must be able to function even if the device which activates the propulsion system of the vehicle is in a position which makes it impossible for the vehicle to operate.

5.12.8. Tell-tale

Circuit-closed tell-tale optional. If there is one, it must not be the same as the tell-tale for the front and rear position lamps.

5.12.9. Other provisions

The functioning of this lamp may also be performed by simultaneously switching on the front and rear position lamps on the same side of the vehicle.

5.13. END-OUTLINE MARKER LAMP

5.13.1. Functional Purpose

Lamps intended for heavy-duty vehicles to indicate the vehicles' overall width.

5.13.2. Number

**2 or 4 visible from the front and
2 or 4 visible from the rear.**

5.13.3. Arrangement

No special requirement.

5.13.4. Position

5.13.4.1. In width:

Front:
as close as possible to the adjacent extreme outer edge of the vehicle.
This condition is deemed to have been met when:

Motor vehicles:

E less or equal to 400 mm

Trailers:

E less or equal 100 mm

Rear:
as close as possible to the adjacent extreme outer edge of the vehicle.
This condition is deemed to have been met when:

E less or equal to 100 mm

5.13.4.2. In height:

Front:

Motor vehicles:

the horizontal plane tangential to the upper edge of the apparent surface in the direction of the reference axis of the device must not be lower than the horizontal plane tangential to the upper edge of the transparent zone of the wind-screen.

Trailers and semi-trailers:

at the maximum height compatible with the requirements relating to the width, design and operational requirements of the vehicle and to the symmetry of the lamps.

Rear:

At the maximum height compatible with the requirements relating to the width, design and operational requirements of the vehicle and to the symmetry of the lamps.

5.13.4.3. In length:

no special requirement.

5.13.5. Geometric visibility

Horizontal angles:

β_1 equal to 45°

β_2 equal to 45°

Vertical angles:

α_1 equal to 10°

α_2 equal to 20°

5.13.6. Orientation

Such that the lamps meet the requirements for visibility forwards and rearwards.

5.13.7. Electrical connections

In accordance with paragraph 4.11.

5.13.8. Tell-tale

Tell-tale optional. If it exists, its function shall be carried out by the tell-tale required for the front and rear position lamps.

5.13.9. Other provisions

Provided that all other requirements are met, the lamp visible from the front and the lamp visible from the rear on the same side of the vehicle may be combined in one device.

5.14. REAR RETRO-REFLECTOR, NON-TRIANGULAR

5.14.1. Functional Purpose

Retro-reflecting devices intended to indicate the presence and width of a vehicle when lamps of that vehicle are off.

5.14.2. Number

Two

5.14.3. Arrangement

No special requirement.

5.14.4. Position

5.14.4.1. In width:

**as close as practicable to the adjacent extreme edge of the vehicle and
E less or equal to 400 mm**

5.14.4.2. In height:

H2 more or equal to 350 mm

H1 less or equal to 900 mm (1,500 mm if the shape of the bodywork makes it impossible to keep within 900 mm).

5.14.4.3. In length:

at the rear of the vehicle.

5.14.5. Geometric visibility

Horizontal angles:

β_1 equal to 30°

β_2 equal to 30°

Vertical angles:

α_1 equal to 10°

α_2 equal to 10° (5° H1 less than 750 mm)

5.14.6. Orientation

Rearwards.

5.14.7. Other provisions

5.14.7.1. The illuminating surface of the retro-reflector may have parts in common with the apparent surface of any other lamp situated at the rear.

5.14.7.2. Additional retro-reflecting devices and materials are permitted provided they do not impair the effectiveness of the mandatory lighting and light-signalling devices.

5.15. REAR RETRO-REFLECTOR, TRIANGULAR 3/

5.15.1. Functional Purpose

Retro-reflecting devices intended to indicate the presence and width of a trailer when lamps of that trailer are off.

5.15.2. Number

Two.

5.15.3. Arrangement

The apex of the triangle shall be directed upwards.

5.15.4. Position

5.15.4.1. In width:

as close as practicable to the adjacent extreme edge of the vehicle and E less or equal to 150 mm (400 mm if the shape of the bodywork makes it impossible to keep within 150 mm).

D more or equal to 600 mm (400 mm if the overall width of the vehicle is less than 1,300 mm)

5.15.4.2. In height:

H2 more or equal to 350 mm

H1 less or equal to 900 mm (1,500 mm if the shape of the bodywork makes it impossible to keep within 900 mm).

5.15.4.3. In length:

at the rear of the vehicle.

5.15.5. Geometric visibility

Horizontal angles:

β_1 equal to 30°

β_2 equal to 30°

Vertical angles:

α_1 equal to 15°

α_2 equal to 15° (5° if H1 less than 750 mm)

5.15.6. Orientation

Rearwards.

5.15.7. Other provisions

5.15.7.1. No other lamp shall be placed inside the triangle.

5.15.7.2. Additional retro-reflecting devices and materials are permitted provided they do not impair the effectiveness of the mandatory lighting and light-signalling devices.

5.16. FRONT RETRO-REFLECTOR, NON-TRIANGULAR 3/

5.16.1. Functional Purpose

Retro-reflecting devices intended to indicate the presence and with of a vehicle when the front lamps of that vehicle are off.

5.16.2. Number

Two.

5.16.3. Arrangement

No special requirement.

5.16.4. Position

5.16.4.1. In width:

as close as practicable to the adjacent extreme edge of the vehicle and

motor vehicle:

E less or equal to 400 mm

trailer:

E less or equal to 150 mm

5.16.4.2. In height:

H2 more or equal to 250 mm

H1 less or equal to 900 mm (1,500 mm if the shape of the bodywork makes it impossible to keep within 900 mm)

5.16.4.3. In length:

at the front of the vehicle.

5.16.5. Geometric visibility

Horizontal angles:

β_1 equal to 30°

β_2 equal to 30°

In the case of trailers:

β_2 may be reduced to 10° .

If because of the construction of the trailers this angle cannot be met by the mandatory retro-reflectors, then additional (supplementary) retro-reflectors shall be fitted, without the width limitation (paragraph 5.16.4.1.), which shall, in conjunction with the mandatory retro-reflectors, give the necessary visibility angle.

Vertical angles:

α_1 equal to 10°

α_2 equal to 10° (5° H1 less than 750 mm)

5.16.6. Orientation

Towards the front.

5.16.7. Other provisions

5.16.7.1 The illuminating surface of the retro-reflector may have parts in common with the apparent surface of any other lamp situated at the front.

5.16.7.2. Additional retro-reflecting devices and materials are permitted provided they do not impair the effectiveness of the mandatory lighting and light-signalling devices.

5.17. SIDE RETRO-REFLECTOR, NON-TRIANGULAR

5.17.1. Functional Purpose

Retro-reflecting devices intended to indicate the presence and length of a vehicle when lamps of that vehicle are off.

5.17.2. Number

Vehicles less than 6,000 mm in length:

4 - 2 on each side of the vehicle.

Vehicles 6,000 mm or more in length:

Such that the requirements for longitudinal positioning are complied with.

5.17.3. Arrangement

no special requirement.

5.17.4. Position

5.17.4.1. In width:

no special requirement.

5.17.4.2. In height:

H2 more or equal to 350 mm

H1 less or equal to 900 mm (1,500 mm if the shape of the bodywork makes it impossible to keep within 900 mm).

5.17.4.3. In length:

K less or equal to 400 mm from the front (600 mm if the shape of the bodywork makes it impossible to keep within 400 mm); in the case of trailers, account shall be taken of the length of the drawbar for the measurement of this distance.

K less or equal to 400 mm from the rear.

vehicles over 6,000 mm long

D_n less or equal to 3,000 mm (If the structure of the vehicle makes it impossible to comply with such a requirement, this distance may be increased to 4,000 mm)

5.17.5. Geometric visibility

Horizontal angles:

β_1 equal to 45°

β_2 equal to 45°

Vertical angles:

α_1 equal to 10°

α_2 equal to 10° (5° if H1 less than 750 mm)

5.17.6. Orientation

Towards the side.

5.17.7. Other provisions

5.17.7.1. The illuminating surface of the side retro-reflector may have parts in common with the apparent surface of any other side lamp.

5.17.7.2. Additional retro-reflecting devices and materials are permitted provided they do not impair the effectiveness of the mandatory lighting and light-signalling devices.

5.18. SIDE-MARKER LAMPS

5.18.1. Functional Purpose

Lamps intended to provide steady light to the side in order to indicate the presence and overall length of the vehicle.

5.18.2. Number.

Vehicles less than 6,000 mm in length:

4 – 2 on each side of the vehicle.

Vehicles 6,000 mm or more in length:

Such that the requirements for longitudinal positioning are complied with.

On chassis-cabs only the front side-marker lamps are required.

5.18.3. Arrangement

no individual specifications.

5.18.4. Position

5.18.4.1. In width:

no individual specifications.

5.18.4.2. In height:

H2 more or equal to 350 mm

H1 less or equal to 1,500 mm (2,100 mm if the shape of the bodywork makes it impossible to keep within 1,500 mm)

5.18.4.3. In length:

Foremost side-marker lamp:

K less or equal to 400 mm (600 mm if the shape of the bodywork makes it impossible to keep within 400 mm)

on trailers equipped with a drawbar:

K more or equal to 1,000 mm from the front of the drawbar and less or equal to 1,500 mm from the front of the drawbar.

Rearmost side marker lamp:

K less or equal to 400 mm

vehicles over 6,000 mm long

D_n less or equal to 3,000 mm (If the structure of the vehicle makes it impossible to comply with such a requirement, this distance may be increased to 4,000 mm)

5.18.5. Geometric visibility

Horizontal angles:

β_1 equal to 45°

β_2 equal to 45°

β_2 for the forward side marker lamps and for the rearward side marker lamp and both β_1 and β_2 angles for the intermediate side marker lamps may be reduced to 30° .

Vertical angles:

α_1 equal to 10°

α_2 equal to 10° (5° if H1 less than 750 mm)

5.18.6. Orientation

Only towards the side.

5.18.7. Electrical connections

In accordance with paragraph 4.11.

The amber side-marker lamps may be wired to flash, provided that this flashing is **[in phase and]** at the same frequency with the direction indicator lamps at the same side of the vehicle.

The amber side-marker lamps may also flash simultaneously in association with vehicle alarm systems and/or immobilisers to draw attention to the vehicle and/or during the arming and disarming of the vehicle's alarm system.

5.18.8. Tell-tale

Tell-tale optional. If it exists, its function shall be carried out by the tell-tale required for the front and rear position lamps.

5.18.9. Other provisions

5.18.9.1. When the rearmost side-marker lamp is combined with the rear position lamp reciprocally incorporated with the rear fog lamp or stop lamp, the photometric characteristics of the side-marker lamp may be modified during the illumination of the rear fog lamp or stop lamp.

5.18.9.2. Additional side-marker lamps are permitted provided they do not impair the effectiveness of other mandatory lighting and light-signalling devices.

5.19. DAYTIME RUNNING LAMP (DRL) 3/

5.19.1. Functional Purpose

Lamps intended to improve the front and front side conspicuity of a vehicle under normal conditions of use during the daytime when the regular headlamps are not required for driving. They are activated without the driver's input whenever the vehicle is in normal condition of use and the headlamps are not switched on. DRL function may be provided by dedicated DRL lamps as described in ECE Regulation No. 87 or SAE J2087, or other lighting or light signalling devices permitted by a Contracting Party.

5.19.2. Number

Two.

5.19.3. Arrangement

No special requirement.

5.19.4. Position

5.19.4.1. In width:

E less or equal to 400 mm

D more or equal to 600 mm (400 mm where the overall width of the vehicle is less than 1,300 mm)

5.19.4.2. In height:

H2 more or equal to 350 mm

H1 less or equal to ~~950~~1,100 mm – may be higher if another, regulated lighting or light signalling device accomplishes daytime running light function.

5.19.4.3. In length:

at the front of the vehicle.

5.19.5. Geometric visibility

Horizontal angles:

β_1 equal to 20°

β_2 equal to 20°

Vertical angles:

α_1 equal to 10°

α_2 equal to 10°

5.19.6. Orientation

Towards the front.

5.19.7. Electrical connections

If installed, the daytime running lamps shall be switched ON automatically each time the device, which starts and/or stops the engine, is in a position, which makes it possible for the engine to operate, unless the automatic transmission control is in the park or neutral position, the parking brake is applied, or the propulsion system is started but the vehicle was not set in motion for the first time.

At the discretion of a Contracting Party means may be required such that the daytime running lamps can be intentionally switched OFF for the remainder of the trip or for a specified time or distance ~~off and subsequently on.~~

The daytime running lamps shall switch off automatically when the headlamps are switched on, except when the latter are used to give intermittent luminous warnings at short intervals.

Rear position lamps are permitted to operate simultaneously with the daytime running lamps.

5.19.8. Tell-tale

Circuit-closed tell-tale mandatory if a vehicle is not equipped with a device automatically activating all lamps required for operation of a vehicle at diminished ambient lighting condition.

5.20. IDENTIFICATION LAMPS (Front and Rear)^{3/}

5.20.1. Functional Purpose

Lamps intended to indicate presence of a wide vehicle.

5.20.2. Number

on motor vehicles over 2,032 mm wide: three facing forward

on all vehicles over 2,032 mm wide excluding truck-tractors: three facing rearward

5.20.3. Arrangement

As specified in paragraph 5.20.4.1.

5.20.4. Position

5.20.4.1. In width:

The lamps shall form a three-lamp group with lamp centres spaced evenly and horizontally with distance of 150 mm to 300 mm between each two lamps. This group shall be mounted horizontally as close as practicable about the median longitudinal plane of vehicle with the reference axis of the middle lamp on that plane.

5.20.4.2. In height:

as high as practicable

The rear identification lamps may be located lower if the door header is narrower than 25 mm, however, H2 shall be more or equal to 350 mm.

5.20.4.3. In length:

no specific requirement.

5.20.5. Geometric visibility

Horizontal angles:

β_1 equal to 45°

β_2 equal to 45°

Vertical angles:

α_1 equal to 20°

α_2 equal to 20°

5.20.6. Orientation

front facing forward and rear facing rearward.

5.20.7. Electrical connections

In accordance with paragraph 4.11.

5.20.8. Tell-tale

Tell-tale optional. If it exists, its function must be carried out by the tell-tale required for the front and rear position lamps.

5.21. CORNERING LAMP 3/

5.21.1. Functional Purpose

Steady burning lamps used in conjunction with the direction indicator system or activated by steering wheel, intended to supplement the headlamps by providing additional illumination in the direction of turn.

5.21.2. Number

Two.

5.21.3. Arrangement

No special requirement.

5.21.4. Position

5.21.4.1. In width:

E less or equal to 400 mm

5.21.4.2. In length:

K less or equal to 1,000 mm

5.21.4.3. In height:

H2 more or equal to 250 mm

H1 less or equal to 900 mm

No point on the apparent surface in the direction of the reference axis must be higher than the highest point on the apparent surface in the direction of the reference axis of the passing-beam headlamp.

5.21.5. Geometric visibility

Horizontal angles:

30° to 60° outwards.

Vertical angles:

α_1 equal to 10°

α_2 equal to 10°

5.21.6. Orientation

Towards the front side.

5.21.7. Electrical connections

The cornering lamps must be so connected that they cannot be on unless the driving-beam headlamps or the passing-beam headlamps are on the same time. The cornering lamp on one side of the vehicle shall be activated when the direction indicators on the same side of the vehicle are switched on and/or when the steering angle is changed from the straight-ahead position towards the same side of the vehicle.

5.21.8. Tell-tale

None.

5.21.9. Other provisions

5.21.9.1. The distance between the cornering lamp and front direction indicator lamp on the same side of the vehicle shall be at least **[20 mm]**.

5.21.9.2. The cornering lamps shall not be activated at the vehicle speed above 40 km/h.

5.21.9.3. The vertical inclination shall be specified by the manufacturer.
For height see paragraph 5.21.4.3. above.

5.22. CONSPICUITY TREATMENT 3/

5.22.1. Functional Purpose

System of retro-reflecting devices provided to increase vehicle's side and rear conspicuity. It augments or replaces the reflex reflectors in their function to indicate the presence and dimensions of a wide, long, and heavy vehicle when lamps of that vehicle are on or especially when lamps of that vehicle are off.

5.22.2. Number

trailers:

**rear: continuous strip across rear lower body and bumper bar, and
if trailer has an upper body structure, 2 pairs of upper body markings
each consisting of two white 300 mm long strips forming inverted "L",**

side: alternating white and red continuous strip or sections

truck tractors:

**rear: 2 pairs of upper body markings each consisting of two white 300 mm long
strips forming inverted "L" on the rear of the cab, and
2 continuous 600 mm long strips, alternating white and red.**

5.22.3. Arrangement

The edge of white sheeting of the conspicuity system shall not be located closer than 75 mm to the edge of the luminous lens area of any lamp required by this regulation.

The edge of red sheeting of the conspicuity system shall be located not closer than 75 mm to the edge of the luminous lens area of any amber lamp specified by this regulation.

5.22.4. Position

5.22.4.1. In width:

upper body markings as far apart as practicable,

trailer:

continuous strip full width of horizontal member of the underride protection device,

truck tractor:

strips as far apart as practicable

5.22.4.2. In height:

upper body markings as high as practicable

Truck tractor:

strips, on fenders, on mud flaps brackets, or within 300 mm below the top of mud flaps.

**If no mud flaps or other supporting structure available on the rear:
strips mounted horizontally on the cab or on frame mounted brackets and as close as practicable to the range of 375 to 1,525 mm above the ground.**

**If on the rear of truck tractor's cab:
minimum 100 mm above the height of rear tires.**

Trailer on the rear:

continuous strip on the frame, as close as practicable to the range of 375 to 1,525 mm above the ground.

continuous strip on the underride protection device, no height requirement.

Trailer on the side:

as close as practicable to the range of 375 to 1,525 mm above the ground

5.22.4.3. In length:

Trailer on the side

full length or evenly spaced segments over minimum of 50 per cent of vehicle's length, starts and ends at the extreme front and rear of the vehicle,

5.22.5. Geometric visibility

As installed on the vehicle, the conspicuity system shall be visible throughout all angles required for the device to comply with photometric requirements, with all vehicular obstructions considered.

5.22.6. Orientation

Rear markings: facing rearward

Side markings: facing sideways

All strips as horizontal as practicable and applied to the surface as vertical as practicable.

Conspicuity treatment manufacturer shall specify acceptable angular deviation from vertical or horizontal.

5.22.7. Electrical connections

N/A

5.22.8. Tell-tale

N/A

5.22.9. Other provisions

N/A

Annex 1

LAMP SURFACES, AXIS AND CENTRE OF REFERENCE,
AND ANGLES OF GEOMETRIC VISIBILITY

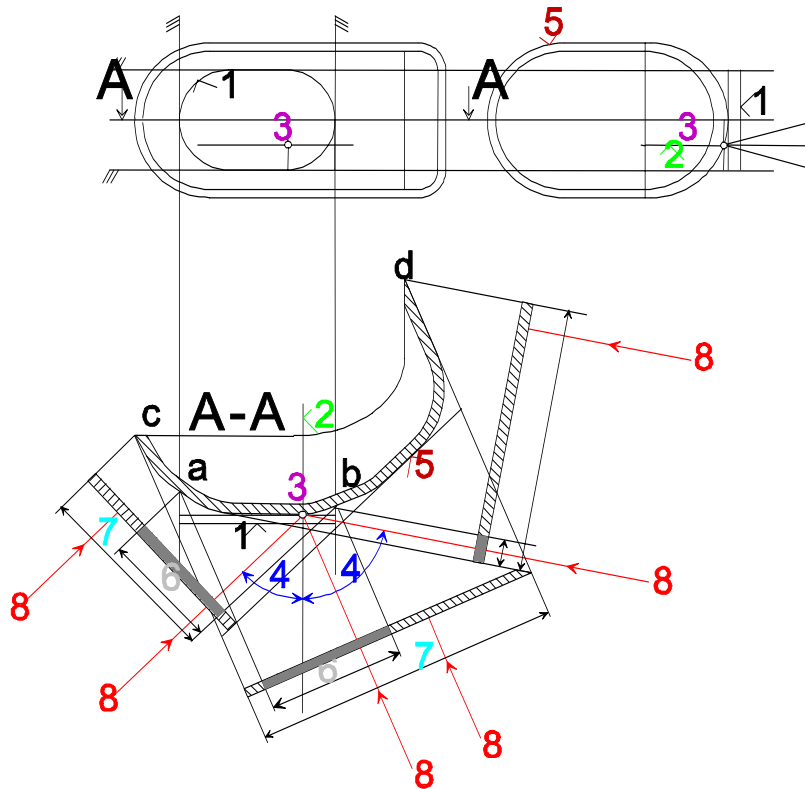

KEY

1. Illuminating surface
2. Axis of reference
3. Centre of reference
4. Angle of geometric visibility
5. Light-emitting surface
6. Apparent surface based on illuminating surface
7. Apparent surface based on light-emitting surface
8. Direction of visibility

Note: Notwithstanding the drawing, the apparent surface is to be considered as tangent to the light-emitting surface.

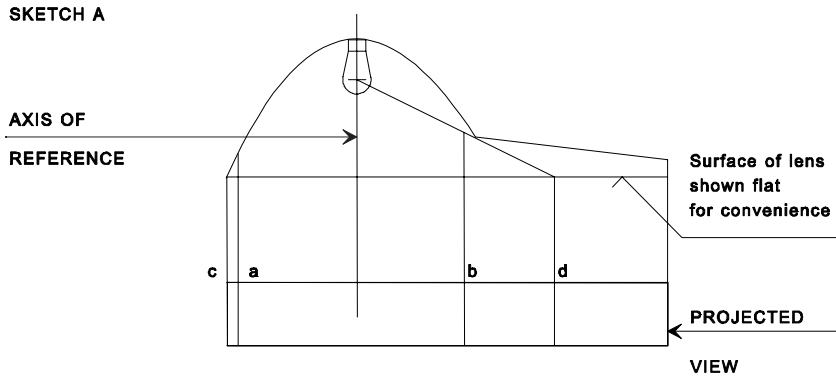

ILLUMINATING SURFACE IN COMPARISON WITH LIGHT-EMITTING SURFACE
 (See paragraphs 3.9. and 3.8. of this regulation)

	Illuminating surface	Light-emitting surface
--	----------------------	------------------------

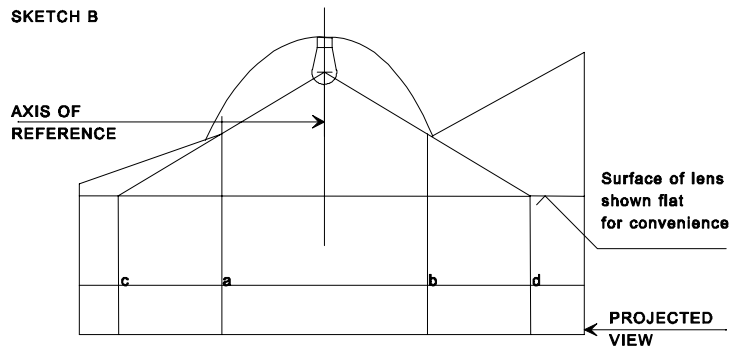

Edges are	a and b	c and d
-----------	---------	---------

	Illuminating surface	Light-emitting surface
Edges are	a and b	c and d

Annex 2

VISIBILITY OF A RED LAMP TO THE FRONT
AND VISIBILITY OF A WHITE LAMP TO THE REAR
(See paragraphs 4.10.1. and 4.10.2. of this regulation)

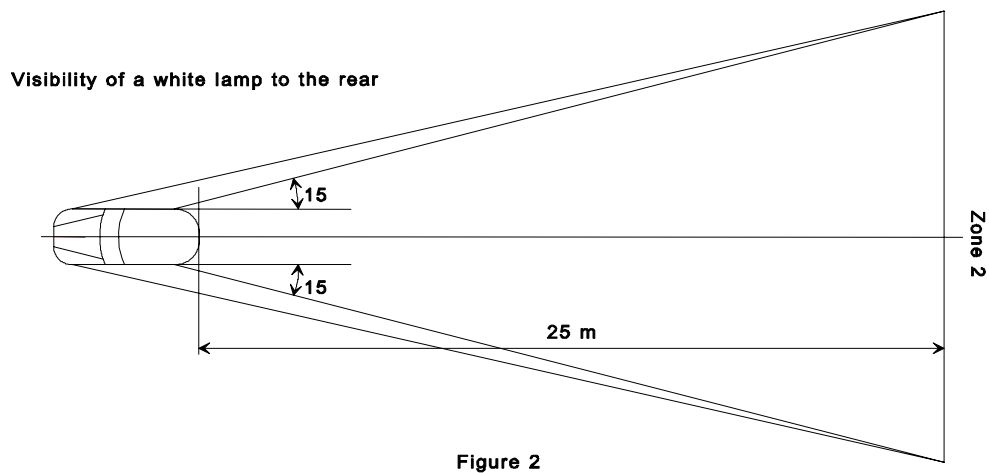
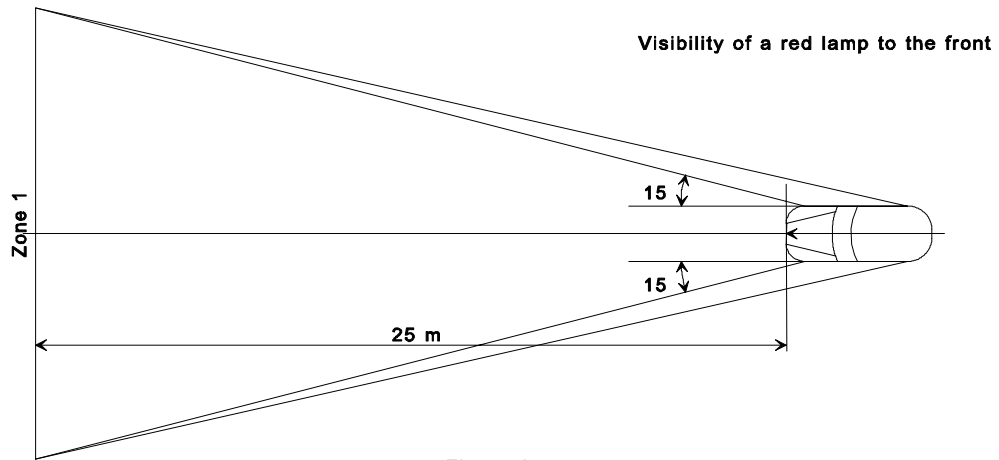

In their respective planes, the zones 1 and 2 explored by the eye of the observer are bounded;

In height: by two horizontal planes 1 m and 2.2 m respectively above the ground,

In width: by two vertical planes which, forming to the front and to the rear respectively an angle of 15° outwards from the vehicle's median longitudinal plane, pass through the point or points of contact of vertical planes parallel to the vehicle's median longitudinal plane delimiting the vehicle's overall width; if there are several points of contact, the foremost shall correspond to the forward plane and the rearmost to the rearward plane.

Annex 3

IDENTIFICATION OF SYMBOLS REGARDING MEASUREMENTS AND ANGLES OF GEOMETRIC VISIBILITY DESCRIBED IN THIS REGULATION

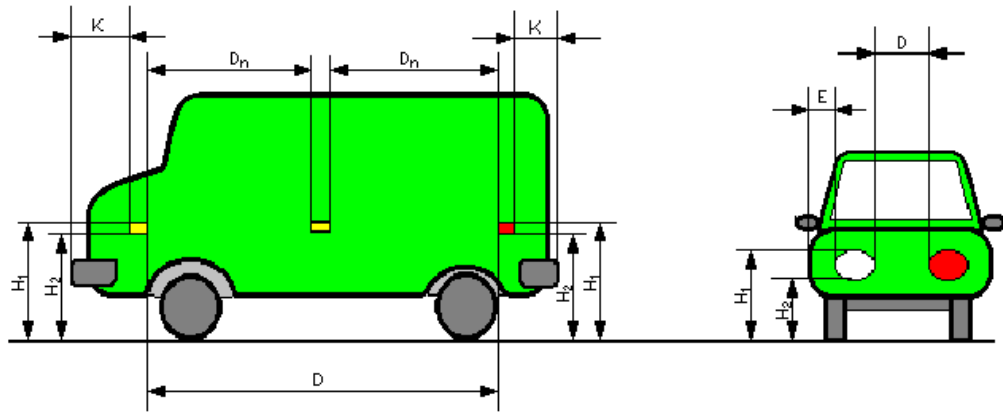

Figure 1. Identification of symbols regarding measurements described in this regulation

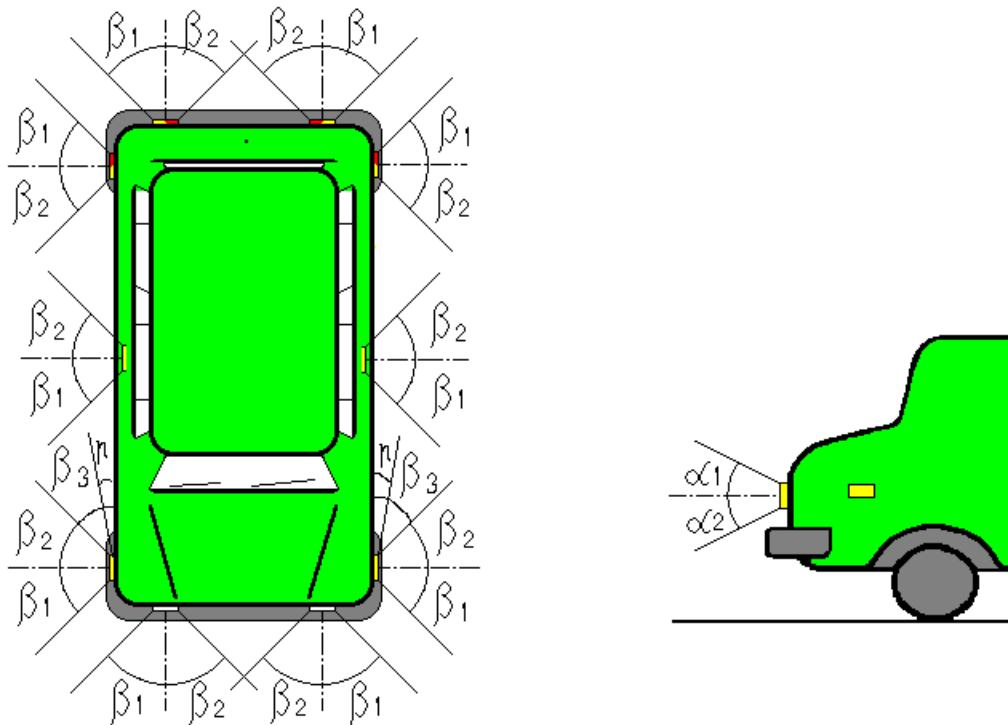

Figure 2. Identification of symbols regarding angles of geometric visibility described in this regulation