

Informal document No. **WP.29-133-12**
(133rd WP.29, 22-25 June 2004,
agenda items 5.2. and B2.3.8.)

PROPOSAL FOR A GLOBAL TECHNICAL REGULATION ON
DOOR LOCKS AND DOOR RETENTION COMPONENTS

Transmitted by the Working Party on Passive Safety

TABLE OF CONTENTS

A	STATEMENT OF TECHNICAL RATIONALE AND JUSTIFICATION.....	3
B	REGULATORY LANGUAGE.....	15
1.	SCOPE AND PURPOSE.....	15
2.	APPLICATION.....	15
3.	DEFINITIONS.....	15
4.	GENERAL REQUIREMENTS.....	17
5.	PERFORMANCE REQUIREMENTS.....	17
6.	TEST CONDITIONS.....	20
7.	TEST PROCEDURE.....	21

ANNEXES

Annex 1	Latch Test for Load Test One, Two, and Three Force Application.....	22
Annex 2	Inertial Test Procedures.....	27
Annex 3	Hinge Test Procedure.....	34
Annex 4	Sliding Side Door, Full Door Test.....	38
Annex 5	Vehicle Category Definitions.....	42

A. Statement of Technical Rationale and Justification

I. Introduction

Current regulations were designed to test for door openings in vehicles that were built in the 1960s. Aside from changes made to U.S. and Canadian requirements in the early to mid-1990s to address rear door openings, no significant changes have been made to any of the current regulations. While existing regulations governing door openings have proven largely effective, doors openings continue to present a risk of serious injury or death to vehicle occupants, particularly when an occupant is unbelted.

The precise size of the safety problem posed by inadvertent door openings is difficult to quantify because very few jurisdictions gather the type of crash data needed to evaluate the problem. This task is further compounded by the effect of occupant belt use on injury risk. Notwithstanding the difficulty in quantifying the overall benefit associated with the establishment of a global technical regulation internationally, the types of changes to door retention components needed to upgrade existing regulations and standards appear to be quite small. Additionally, vehicle manufacturers, and the ultimate consumers of motor vehicles, can expect to achieve further cost savings through the formal harmonization of differing sets of regulations and standards that already largely replicate each other.

Research conducted by the United States indicates that there are approximately 42,000 door openings in crashes in the United States per year.¹ While this number corresponds to less than one percent of the roughly six million crashes that occur in that country each year, the majority of those crashes do not occur at speeds where a door opening is likely. Rather, door failures appear to be most common in moderate- to high-speed crashes.²

Structural failures of the latch and striker are the leading cause of door openings. The United States' evaluation of its data indicates that about two-thirds (64.5 %) of door openings involve damage to the latch or striker, either alone or in combination with damage to one or more hinges. The next most likely causes of a door opening are the failure of the vehicle structure holding the door in place or the door itself. In 8.37 % of the evaluated cases, the door support, e.g., B-pillar or C-pillar, was damaged; while in 9.68 % of the evaluated cases, the door structure caused the door to open without damaging the actual door retention components. Only rarely did a door open with no damage to the door whatsoever (2.15 %).

The type of crash also has an impact on the likely type of door failure. The primary source of failure in side impact crashes was damage to the latch/striker assembly, while damage to the door supports was a distant secondary source. In rollover crashes, non-structural failures, i.e., those where there is no damage to the door, are more common.

¹ At the request of the Working Party on Passive Safety, the U.S. provided data on the magnitude of the door ejections and door openings based on 1994-99 National Automotive Sampling System (NASS) and Fatal Analysis Reporting System (FARS) annual estimates. No data from other jurisdictions were presented.

² In the United States the average delta V for crashes where a door opens is approximately 30.5 km/h; the average delta V for crashes where there is no failure of the door retention system is approximately 21 km/h.

In 1991, the United States conducted an engineering analysis of door latch systems in cases involving vehicle side door openings to determine the loading conditions and failure modes of door latch systems in crashes.³ This analysis revealed the following four distinct failure modes:

Structural Failures. Structural failures are characterized as physical damage to the latch, striker, or hinges. Other types of structural failures include broken attachment hardware or separation of a latch, striker, or hinge from its support structure.

Detent Lever-Fork Bolt Misalignment (Bypass) Failures. Detent lever-fork bolt misalignment (bypass) failures may occur when the striker is subjected to longitudinal forces in conjunction with lateral forces. These forces cause the fork bolt to move and become misaligned with the detent lever, causing the latch to open. These forces most typically occur in frontal and oblique frontal impacts.

Linkage Actuation Failures. Linkage actuation failures are caused by forces being transmitted to the door's linkage system (i.e., the connection between the door handle and the door latch) due to vehicle deformation during a crash. It may be possible to observe some bowing of the door after a linkage actuation failure.

Inertial Force Failures. Inertial force failures are latch openings due to acceleration of latch system components relative to each other, which produce sufficient inertial force to activate the latch. Often, there is no visible damage to the latch or striker system. Inertial loading typically occurs in rollover crashes or when a portion of the vehicle other than the door is impacted at a high speed.

These four failure modes can be categorized as either structural failures or actuation failures. Structural failures usually leave clear evidence of the component failure and result in an inoperable door retention system. Actuation failures consist of latch by-pass, linkage actuation, and inertial force failures. Often a door opening caused by an actuation failure will not leave any readily visible evidence that the crash caused the door to open and will not affect the retention system's subsequent ability to open and close correctly. Thus, many of the failures associated with a latch by-pass, linkage actuation, or inertial force failure will be represented by the 2.15 % of crashes where no damage to the door was observed.

According to the U.S. statistics, less than one percent of occupants who sustain serious and fatal injuries in tow-away crashes are ejected through doors. Yet, despite the relatively rare occurrence of door ejections in crashes, the risk of serious or fatal injury is high when ejection does occur. Door ejections are the second leading source of ejections in all crashes in the U.S. They are particularly likely in rollover crashes. Door ejections constitute 19 percent (1,668) of all ejection fatalities and 22 percent (1,976) of all ejection serious injuries in the United States each year. Of the approximately 42,000 door openings in the U.S. each year, side door openings constitute approximately 90 percent (1,501) of all door ejection fatalities and 93 percent (1,838) of the serious injuries.

The rate of ejections through doors is heavily dependent on belt use. 94 % of serious injuries and fatalities attributable to ejections through doors in the United States involve unbelted occupants. While

³ Door Latch Integrity Study: Engineering Analysis and NASS Case Review, December, 1991, Docket No. NHTSA-1998-3705.

the risk of ejection will likely vary from jurisdiction to jurisdiction, based on differing rates of belt use, the incidence of door openings should be relatively constant among various jurisdictions given the similarity in door designs and the lack of occupant behaviour patterns as a factor in door failures.

II. Procedural Background

During the 126th session of WP.29 of March 2002, the Executive Committee of the 1998 Global Agreement (1998 Agreement) adopted a Program of Work, which includes the development of a global technical regulation (gtr) to address inadvertent door opening in crashes. The Executive Committee also charged the Working Party on Passive Safety (GRSP) to form an informal working group to discuss and evaluate relevant issues concerning requirements for door locks and door retention components to make recommendations regarding a potential gtr.

The informal working group was established in September 2002. The United States volunteered to lead the group's efforts and develop a document detailing the recommended requirements for the gtr. The U.S. presented a formal proposal to the Executive Committee of the 1998 Agreement, which was adopted in June 2003 (TRANS/WP.29/2003/49). The GRSP developed the door lock and door retention gtr. At its May 2004 session, the GRSP concluded its work and agreed to recommend the establishment of this gtr to the Executive Committee.

III. Existing Regulations, Directives, and International Voluntary Standards

There are several existing regulations, directives, and standards that pertain to door locks and door retention components. All share similarities. The Canadian and US regulations are very similar to each other and the Japanese and ECE regulations are very similar to each other. The European Union Directive is an exact alternative of the ECE regulation requirements. The Australian regulation has commonalities to both of the above-mentioned pairs. A preliminary analysis has been made to identify the differences in the application, requirements, and test procedures of the North American and ECE R11 regulations (TRANS/WP.29/GRSP/2001/1 and TRANS/WP.29/2003/49). There are no apparent conflicts between the gtr and other existing international regulations or standards. However, the gtr does incorporate aspects of the existing regulations, directives and standards that are not common to all existing requirements. Given the generally minor variability in the door retention designs among these jurisdictions that currently regulate door design, it is not expected that the additional requirements imposed by the gtr are likely to drive major, costly changes to existing door retention designs.

IV. Discussion of Issues Addressed by the GTR

The proposed gtr provides that certain door retention components on any door leading directly into an occupant compartment, i.e., a compartment containing one or more seating accommodations, must comply with the requirements of the gtr. Tractor trailers are excluded because they do not meet this criterion. Likewise, doors leading into cargo compartments that are separated by a barrier would not be regulated since an individual could not access the occupant compartment through those doors. The gtr excludes folding doors, roll-up doors, detachable doors, and doors that provide emergency egress, as these types of doors would require entirely new test procedures and are not in such common use as to justify the development of new requirements and test procedures. Thus, for certain vehicle designs, some, but not all doors would be regulated by the gtr.

During the development of the gtr, all sections were thoroughly discussed. The following discussions reflect the evaluation of the issues that lead to the final recommendations.

a. Applicability

The application of the requirements of this gtr refers, to the extent possible, to the revised vehicle classification and definitions that the Working Party on General Safety (GRSG) Common Task Group has prepared. Difficulties were encountered in determining which vehicles would be covered. Currently, ECE regulations only apply to M1 vehicles (passenger vehicles with up to 9 seats in total) and N1 vehicles (goods vehicles weighing up to 3,500 kg gross vehicle mass). It was posited that it would be difficult to apply full door tests, such as the proposed inertial load, to large trucks and specialized vehicles. With the decision not to propose the inclusion of two full door tests, discussed in greater detail below, these concerns were largely resolved. Likewise, the retention of a calculation for meeting the inertial load requirements would allow a jurisdiction to avoid applying a full-door inertial load test for doors on heavier vehicles. To address concerns about the applicability of door retention requirements on heavier vehicles, it was proposed that the gtr only apply to passenger cars, light commercial vehicles, and vans and that other vehicles be excluded initially, then added in the future after further evaluation of various door designs. The argument in favor of a more inclusive gtr focuses attention on the current U.S., Canadian, Japanese, and Australian requirements that already apply to all vehicles other than buses (M2 and M3 vehicles) and that the applicability of existing requirements to commercial trucks has not proven problematic for vehicle manufacturers. This argument supports the exclusion of specific door types rather than entire classes of vehicles.

Heavy trucks in the U.S. have been subject to that country's door retention requirements since 1972. The U.S. requirement was extended to trucks because researchers from a major U.S. university determined in a study published in 1969 that the rate of door ejection from truck doors was approximately twice that from doors on passenger cars that met the door retention requirements. The authors of the study concluded that at 40.3 %, the level of door failure in the truck fleet was approximately four times the failure rate of regulated passenger cars and roughly equivalent to the rate of failure in passenger cars manufactured before 1956. They also concluded that sufficient door retention was a problem across vehicle weight classifications, with pick-up trucks, medium-weight trucks and tractor trailers all exhibiting a door failure rate in excess of 33%.

To accommodate both positions, the gtr will apply to all vehicles except buses, with exceptions for specific door designs. The gtr incorporates the definitions of Category 1-1 vehicles and Category 2 vehicles developed in draft Consolidated Resolution (R.E.) 5, which will be finalized in the near future. If a jurisdiction determines that its domestic regulatory scheme is such that full applicability is inappropriate, it may limit domestic regulation to vehicles with a gross vehicle weight of 3,500 kg or less. The jurisdiction could also decide to phase-in the door retention requirements for heavier vehicles, delay implementation for a few years, or even to impose only some of the gtr requirements to these heavier vehicles. For example, it is unlikely that a jurisdiction would want to require heavier truck doors meet the dynamic inertial test rather than the calculation. On the other hand, the longitudinal and transverse load requirements have been applicable to heavy trucks in the U.S. and Canada for over thirty years without imposing any hardship on vehicle manufacturers.

b. Definitions

Definitions, used in this gtr, are defined in section B, paragraph 3 of this regulation, with the exception of those related to the applicability. Definitions that relate to the applicability are drawn from the draft R.E. 5 and are listed in Annex 5.

c. General Requirements

The GRSP agreed to recommend that the gtr should specify requirements for side and back doors, door retention components and door locks. U.S., Canadian, and Australian regulations have provisions for back doors and door locks, the ECE regulations do not.

Currently, ECE regulations require that the sliding door systems be tested in a fully latched position and an intermediate latched position. If there is no intermediate position, when unlatched, the door must move into an apparent open position. The U.S and Canadian regulations have no latching system requirements for the sliding doors. The working party decided it was appropriate to regulate the sliding side door latching system, but recognized that the existing ECE requirement to determine whether a sliding side door was unlatched was too subjective. Accordingly, the gtr specifies a door closure warning system that activates when the sliding side door is not latched and there is no intermediate/secondary latching position.

The inclusion of a requirement in the gtr that side doors remain shut during vehicle dynamic crash tests, as well as a requirement that at least one door per row be operable following a crash test, was considered. Existing ECE regulations with dynamic crash test components already require all doors to stay closed during the test and at least one door per seat row to be operable afterwards. It is believed that it is unnecessary to repeat this requirement in the gtr and its inclusion would make the certification process under this regulation very difficult. However, recognizing the value of such a requirement, non-ECE countries have agreed to consider including a similar requirement in their domestic regulations. This will result in a harmonized requirement outside of the context of the gtr.

Force levels identified in the current component static tests for latches and hinges have been harmonized to eliminate variations due to rounding of unit conversions.

d. Performance Requirements

i. Hinged Doors Issues

Currently, ECE R11 has similar hinged door requirements to FMVSS No. 206, although ECE R11 does not distinguish between cargo and non-cargo door latches. The working party agreed to recommend that cargo doors (i.e., double doors) meet the same requirements as hinged doors if they provide access to the occupant seating compartment. Additionally, the term “cargo door” has been eliminated to clarify that doors that do not lead into an occupant compartment with one or more seat positions are not regulated by the gtr.

ii. Load Tests

Both regulations require load tests of the hinge systems in the longitudinal and transverse directions. These tests remain, but have been reworded such that the loads are applied based on the alignment of the hinge system and not the alignment of the vehicle. A load test in the vertical direction was evaluated and ultimately rejected except for back doors. Since a large number of door openings occur during vehicle rollovers, it was suggested that perhaps a load test in the vertical direction would help reduce these types of openings. However, it was ultimately determined that the addition of a load test

conducted in a direction orthogonal to the existing tests could not be justified at the present time. Those countries concerned about protecting against rollover crash door openings may determine that such a test would be useful outside the context of the gtr.

iii. Inertial Test

A dynamic inertial test requirement was added to the gtr, as an option to the inertial calculation. There are provisions for this type of testing in both the ECE and North American regulations, but there is no specified test procedure. A test procedure was developed based on the testing currently conducted for the ECE requirement and validated by the US and Canada. In addition to the longitudinal and transverse tests, tests in the vertical direction were considered. Conducting the inertial test in the vertical direction is feasible, but it is much more difficult to conduct than the tests in the longitudinal and transverse directions. Since the most common failure mode demonstrated in the inertial tests conducted by Canada was in the direction of door opening, the committee determined that a test in the vertical direction appeared to be beneficial only for back door designs, which commonly open in the vertical direction. However, those countries concerned about protecting against rollover crash door openings may determine that such a test would be useful outside the context of the gtr.

iv. New Combination Component Test

The U.S. developed a new combination test procedure for hinged side doors that is representative of the combination of longitudinal compressive and lateral tensile forces that occur in real-world latch failures. Currently, no regulation, directive, or international voluntary standard has such a requirement, although it is possible that a test developed by one vehicle manufacturer may be suitable for substitution once it has been fully evaluated and a benefits correlation has been conducted.

Examples of the types of crashes in which forces addressed by the combination test could occur are crashes in which either the front or the rear of the vehicle is impacted (including in an offset mode). The proposed combination test procedure was a static bench test capable of evaluating the strength of the latching systems and designed to detect fork bolt detent bypass failures. No other test procedure within the gtr simulates these types of latch failure conditions.

In the combination test, the latch is mounted on a flat steel plate that moves horizontally and the striker is mounted on a vertically moving ram device. During the test, the latch and striker, while in their primary coupled position, are simultaneously moved such that lateral tension (i.e., force applied perpendicularly to the coupled latch and striker) and longitudinal compressive forces (i.e., force applied against the latch toward the striker) are applied at their interface.

The required forces for the primary position of the hinged side door latching systems would be simultaneous forces of 16,000 N longitudinal compressive force and 6,650 N lateral tensile force. The longitudinal force application device is moved at a rate of one centimeter per minute until the longitudinal force is achieved.

There is widespread support for a test that addresses the door failure modes represented by this test. However, in some vehicles, the test set-up is such that the striker cannot interface with the faceplate of the latch, rendering the test meaningless. While it is possible to modify the striker portion of the latch system so that the test can be conducted, there is strong concern regarding the adoption of this type of procedure and its potential for enforceability questions.

The adoption of the combination test into the gtr is not supported at this time due to the technical difficulties in conducting the test. Instead, the working party delegates and representatives will continue to review work on the modification of the U.S.-based procedure, or the development of a new procedure, to capture the benefits associated with a test addressing door failures due to simultaneous compressive longitudinal and tensile lateral loading of latch systems in real world crashes. Any acceptable procedure developed could then be added to the gtr as an amendment.

v. Door Hinges

Both the ECE and FMVSS regulations have the same load testing requirements for door hinges. The current side door requirements for hinges, which are based on SAE Recommended Practice J934, *Vehicle Passenger Door Hinge Systems*, appear to test adequately the strength and design of door hinges. The United States' comprehensive analysis of its data and possible failure modes has not revealed problems with door hinges. Accordingly, these requirements have been included in the gtr. The current ECE requirements only allow for the hinges to be mounted on the forward edge in the direction of travel. This requirement was based on the safety concern of a possible inadvertent opening while the vehicle is in motion. This requirement, as stated, was found to be design restrictive and the safety concerns were resolved by developing text to regulate the design and not prohibit it.

vi. Hinged Side Door System Tests (Full Door Tests)

A new series of test procedures was designed to simulate real world door openings in crashes. These tests consist of door-in-frame quasi-static (full door) tests in both longitudinal and lateral directions, independent from the door system.

The lateral full door test is designed to simulate latch failures in crashes that produce outwards forces on the door (i.e., through occupant loading or inertial loading) such as side crashes that result in vehicle spin and rollover. The longitudinal full door test is designed to simulate a collision in which the side of the vehicle is stretched, leading to the possibility that the striker could be torn from its mated latch (i.e., far side door in side impacts, and front and rear offset crashes on the opposite side door).

The inclusion of the full door tests in the gtr was not supported because the tests raise concerns about unduly restricting door designs, developing a repeatable and enforceable test procedure, and addressing door openings under real world conditions. Because of the current ECE requirement for both the component tests and a door closure requirement in dynamic tests, there is some question as to whether a full door test provides any additional value. In an analysis of the proposed tests using its FARS and NASS databases, the United States was unable to correlate the proposed tests with a reduction on door openings in real world crashes at a level that was statistically significant.

The contemplated test procedures were evaluated and concerns were expressed that the new procedure will end up being unduly design restrictive, given the limitations of the test frame. For example, it may be that multiple test frames would be required to ensure an appropriate "fit" between the door and the test frame. This is because placement of the test load relative to the latch mechanism may be sufficiently different to produce significantly different results, and because door specific holes must be drilled into the test frame. Additionally, the test frame may not adequately address new latch designs that may be mounted in non-traditional locations. Likewise, the procedure does not allow

manufacturers the benefit of non-latch attachments that are primarily used for side impact purposes but also may have a positive effect on door closure.

Concerns were voiced that conducting the proposed tests on a test frame rather than on the full vehicle is impractical because not all loads can be applied to a closed door. However, it may be possible to cut the door frame and attach it to the test fixture, although such an approach may not fully replicate the actual door-in-frame as installed in the vehicle since cutting the door frame may change its characteristics. Such an approach may address the fit between the latch and striker, as well as the physical characteristics of the door and the doorframe. Accordingly, it was finally agreed not to include these proposals.

vii. Side Sliding Doors Issues

The requirements and test procedures in both ECE R11 and the North American standards for the track and slide combinations of side sliding doors are included in the gtr. The latch/striker system requirements of ECE R11 are also included. However, neither regulation had a detailed full vehicle sliding door test procedure that simulates real world door openings in crashes.

Simply testing the strength of the latch fails to fully account for the design of a sliding door. The current regulations for hinged doors adequately address door retention components because they test both the latch system and the hinge system. Since a sliding door has no hinges, only the latch is evaluated. The lack of a test for retention components other than the latch is an obvious weakness in the existing standards. Yet evaluating these components through a bench test would be impossible. The retention components simply are not amenable to a component test. The full-door test overcomes the lack of a component test similar to the hinge test for other doors by evaluating all retention components while the door interfaces with the doorframe.

The procedure involves a full vehicle test in which a sliding door is tested by applying force against the two edges of the door. The test setup is initiated by placing two loading plates against the interior of the door. The loading plates are placed adjacent to the latch/striker system located at the door edge. If the door edge has two latch/striker systems, the loading plate is placed between the two systems. If a door edge does not have a latch/striker system, the loading plate is placed at a point midway along the length of the door edge. An outward lateral force of 18,000 N total is then applied to the loading plates, placing force against the two door edges. A test failure would be indicated by a 100 mm separation of the interior of door from the exterior of the vehicle's doorframe at any point or either force application device reaching a total displacement of 300 mm. The gtr requires that there be no more than 100 mm of separation, even if the latch system does not fail, because, unlike hinged doors, the configuration of sliding doors allows for separation of the door from the frame without the latch system failing. The 100 mm limit is based on a commonly used measurement for maximum allowable open space in U.S. and Canada for school bus opening requirements.

The sliding door test procedure specifies that the test be conducted with force application devices that, when installed as part of the test setup, are each capable of reaching a total displacement of at least 300 mm after placement of the loading plates against the interior of the door. Under the test, the force application device displacement must be sufficiently large to permit a test failure. Assuming a distance between the interior of the door and its outside skin of approximately 100 mm, the force application device must be capable of displacing at least 200 mm. Additionally, because one force application

device may displace (typically on a door edge without a latch system) while the other holds a constant steady force, some additional displacement may be required to move the failing edge of the door at least 100 mm. Accordingly, the test procedure has been changed to specify the use of force application devices capable of at least 300 mm displacement. Longer force application devices may be used, but are not required.

The test procedure has been further refined to ensure the load is maintained for a sufficient period to allow measurement of any separation between the door and doorframe. Concerns were raised regarding the sustained application of an 18,000 N load while measuring the gap between the door and its frame. The safety of the technicians conducting the test is a paramount concern. However, the complete release of the load prior to measuring the gap could result in a relaxation of the door position and a consequent reduction of the maximum gap achieved. It is likely that many test facilities may choose to measure separation during the application of load by some means other than attempting to pass an item through the door opening.

viii. Door Locks

Unlike the door lock and door retention component requirements in North America, ECE R11 does not have provisions for door locks. It was agreed to recommend the North American requirements for front door locks of having the outside handle be inoperative when the locking mechanism is engaged, since this is already standard practice in Europe and Japan. There was more debate over the requirements for rear door locks.

The North American standards require that when the door lock is engaged, both the inside and outside release controls shall be inoperative. Concerns were expressed about including such requirements in the gtr, because it might hamper egress from the vehicle in a post crash environment. It was, conversely, argued that such requirements are necessary for the protection of children in the rear seat. In discussing this issue, several recommendations were made for inclusion in the gtr:

- i) a door that can be opened with a single movement of the door handle when the door is in a locked position must be fitted with a child safety lock,
- ii) automatic door locks that allow the driver to engage or disengage the child safety locks from the front seat would be acceptable,
- iii) doors that require some action other than the release of the door with a single movement of the door handle when the door is in a locked position may have child locks, but would not be required to have such locks; these doors could be required to have a manual door-lock release that would allow rear-seat passengers to open the door in the event of a crash.

The U.S. indicated that child locks are not regulated in the current North American standards, and that it is important that doors not be allowed to open from the interior with a single movement of the door handle when the door is locked.

The philosophical difference in opinion on how to best address the need for egress from a rear seat, while respecting the need to prevent children from opening a locked door, precluded a single solution to rear door lock requirements. Instead, it was agreed to recommend that the interior door locking mechanism on a rear door, when engaged, must be releasable by an action other than the simple, single pull on the interior door handle. In some instances, the locking mechanism is incorporated directly into the door handle. For such systems, the single movement of the handle cannot be sufficient to unlock and unlatch a locked latch system. In others, the locking mechanism functions separately from the

interior door handle, and no amount of movement will operate the door lock. Since movement of the handle has no effect on the lock release mechanism, there would be no restriction on this movement. Both systems meet the regulatory requirement that the interior door handle or other interior latch release control may not operate when the door is locked. A jurisdiction may require that the separate action be directly available to either the driver of the vehicle or an occupant immediately adjacent to the locked door, or that the vehicle be equipped with either an automatic or manual child lock system. Currently ECE and Japanese regulations have no requirements for door locks. However, based on comments from working party delegates and representatives, it appears that Japanese manufacturers could meet the first option while European manufacturers could meet the second option without any changes in vehicle design. Neither type of system would be prohibited as a supplemental safety device, and a jurisdiction could determine that either system was acceptable as the primary safety device.

V. Regulatory Impact and Economic Effectiveness

The adoption of the gtr will result in an overall reduction in door openings, and associated injuries and fatalities, while maximizing economic effectiveness of door retention regulations globally. In order to estimate the potential costs and benefits associated with a harmonized gtr on door retention components, an economic analysis of the new requirements was conducted. First, those requirements that would be new to the U.S. and Canadian regulations were evaluated. Second, those requirements that would be new to ECE R11 were evaluated. Since the Australian regulation contains requirements similar to both sets of regulations, no separate analysis was conducted. Finally, those requirements that are new to both sets of regulations were considered.

It is estimated that the addition of secondary latching requirements to double doors and sliding doors not equipped with a telltale would not constitute an additional cost to manufacturers for the U.S. and Canadian market (ECE R11 already has such a requirement). This is because a cursory survey of vehicles equipped with double doors in the United States revealed that all such doors were already equipped with latches with both a fully and secondary latch position. The same was true of sliding doors. However, inclusion of a secondary latch requirement for these doors will insure that future design changes will not eliminate latches with a secondary latch position. Additionally, it is possible that there are some vehicles manufactured in two or more stages that have double or sliding doors without a secondary latch position. Many of the double doors on these vehicles may be outside of the scope of the gtr because they do not lead directly into an occupant compartment. Others may need to have a secondary latch position added. Based on a 1995 evaluation of its new back door requirements, the U.S. estimates that the cost of adding a secondary latch position is not more than \$1.20 (U.S.) per latch, when adjusted for inflation.

The gtr also proposes to offer an option for inertial testing, while retaining a calculation for determining whether a latch has been designed to sufficiently withstand inertial forces. While ECE R11 already provides an abbreviated test requirement that may be conducted in lieu of the calculation, the U.S. and Canadian standards do not. Because the gtr allows for a calculation rather than testing, it is possible that this addition will have no corresponding cost. Even if the U.S. and Canada were to require inertial testing for some door latch systems, there is no indication that existing latches would need to be redesigned. This is because the calculation requirements should already insure that sufficient countermeasures have already been taken to address inertial loading. In the event some redesigns are required, the cost of such redesigns cannot be quantified at this time.

The primary new requirement impacting only manufacturers producing vehicles under the aegis of ECE R11 is the addition of new back door requirements. Back door retention systems have been regulated in the U.S., Canada and Australia since the mid-1990s. These requirements apply to hatchbacks, station wagons, vans, and sport utility vehicles. In the final rule establishing new back door requirements in the United States, the U.S. estimated that by 1998 there would be approximately 160 fatalities and 200 serious injuries in the United States each year resulting from back door ejections. Adding new back door requirements was expected to reduce these numbers by 13 fatalities and 17 serious injuries per year. The U.S. determined that the cost of needed door upgrades would amount to no more than \$5.00 (U.S.) per affected vehicle. These costs are further broken down by the addition of a secondary latch position (\$0.00-1.00 (U.S.)), the addition of an interior door handle and latch release mechanism (\$0.00-1.00 (U.S.)), and improvements required to meet hinge force requirements (\$0.00-3.00 (U.S.)). The cost associated with meeting the new latch force requirements in three directions was too nominal to be calculated. When adjusted for the inflation rate in the United States, the overall cost of back door requirements would be no more than \$6.00 (U.S.) per door.

The sliding door test requirements are new to manufacturers under both the ECE system and the U.S./Canadian systems. The new sliding door requirement is designed to address ejections related to door retention components on sliding doors other than the latch. U.S. data indicates that there are approximately 926 sliding door failures each year. These failures cause 44 ejections per year, resulting in 8 fatalities and 28 serious injuries. Testing indicates that the easiest way to meet the new sliding door test is to install two latches on a sliding door, one at each end. In general, those doors equipped with two latches performed well, while those with only one latch did not. This is likely because the door retention components other than latches are insufficient to retain the door. The cost of adding a second latch is estimated to be between \$5.00-10.00 (U.S.). To the extent the new test requires an upgrade to latches already installed in sliding doors, that cost is estimated to be \$0.25 (U.S.).

The combination test is designed to address door openings that are due to simultaneous forces acting between the latch and striker in offset crashes. No existing tests account for compressive longitudinal loading with a tensile lateral force, even though such loading is relatively common in crashes. While the decision was made to delay including a combination load requirement due to technical difficulties in conducting the test, it appears that such a requirement would be relatively inexpensive and could yield significant benefits. It is anticipated that latch upgrades needed to meet the requirements of the combination tests would be no more than \$0.21 (U.S.). If tested with a longitudinal compressive force of 15,000 N, it is anticipated that 39% of the existing fleet would require some upgrade in order to pass the new test procedure. That failure rate increase to 43% and 67% when the longitudinal forces are increased to 17,000 N and 19,000 N, respectively. At the proposed 16,000 N load, the reduction in door openings is estimated to be between 8.9% and 13.3%. Based on the number of ejections through side hinged doors in the crash modes represented by the combination test, the new requirement would result in an annual reduction of 28 to 41 fatalities and 17 to 27 serious injuries in the United States alone.

B. REGULATORY LANGUAGE

1. Scope and Purpose. This regulation specifies requirements for vehicle door locks and door retention components, including latches, hinges, and other supporting means, to minimize the likelihood of occupants being thrown from a vehicle as a result of impact.
2. Application. This regulation applies to vehicle door locks and door retention components on side or back doors that lead directly into a compartment that contains one or more seating accommodations in Category 1-1 vehicles, or Category 2 vehicles.
3. Definitions. For the purpose of this gtr, vehicle categories, listed in paragraph 2, are defined in Annex 5
 - 3.1 "Auxiliary Door Latch" is a latch equipped with a fully latched position and fitted to a door or door system equipped with a primary door latch system.
 - 3.2 "Auxiliary Door Latch System" consists, at a minimum, of an auxiliary door latch and a striker.
 - 3.3 "Back Door" is a door or door system on the back end of a motor vehicle through which passengers can enter or depart the vehicle or cargo can be loaded or unloaded. It does not include:
 - (a) A trunk lid; or
 - (b) A door or window that is composed entirely of glazing material and whose latches and/or hinge systems are attached directly to the glazing material.
 - 3.4 "Body Member" is that portion of the hinge normally affixed to the body structure.
 - 3.5 "Child Safety Lock System" is a locking device which can be engaged and released independently of other locking devices and which, when engaged, prevents operation of the interior door handle or other release device. The lock release/engagement device may be manual or electric and may be located anywhere on or in the vehicle.
 - 3.6 "Door Closure Warning System" is a system that will activate a visual signal located where it can be clearly seen by the driver when a door latch system is not in its fully latched position and while the vehicle ignition is activated.
 - 3.7 "Door Hinge System" is one or more hinges used to support a door.
 - 3.8 "Door Latch System" consists, at a minimum, of a latch and a striker.
 - 3.9 "Door Member" is that portion of the hinge normally affixed to the door structure and constituting the swinging member.

- 3.10. "Door System" is the door, latch, striker, hinges, sliding track combinations and other door retention components on a door and on its surrounding doorframe. The door system of a double door includes both doors.
- 3.11. "Double Door" is a system of two doors where the front door or wing door opens first and connects to the rear door or bolted door, which opens second.
- 3.12. "Fork-bolt" is the part of the latch that engages and retains the striker when in a latched position.
- 3.13. "Fork-bolt Opening Direction" is the direction opposite to that in which the striker enters the latch to engage the fork-bolt.
- 3.14. "Fully Latched Position" is the coupling condition of the latch that retains the door in a completely closed position.
- 3.15. "Hinge" is a device used to position the door relative to the body structure and control the path of the door swing for passenger ingress and egress.
- 3.16. "Hinge Pin" is that portion of the hinge normally interconnecting the body and door members and establishing the swing axis.
- 3.17. "Latch" is a device employed to maintain the door in a closed position relative to the vehicle body with provisions for deliberate release (or operation).
- 3.18. "Primary Door Latch" is a latch equipped with both a fully latched position and a secondary latched position.
- 3.19. "Primary Door Latch System" consists, at a minimum, of a primary door latch and a striker.
- 3.20. "Secondary Latched Position" refers to the coupling condition of the latch that retains the door in a partially closed position.
- 3.21. "Side Front Door" is a door that, in a side view, has 50 per cent or more of its opening area forward of the rearmost point on the driver's seat back, when the seat back is adjusted to its most vertical and rearward position.
- 3.22. "Side Rear Door" is a door that, in a side view, has 50 per cent or more of its opening area to the rear of the rearmost point on the driver's seat back, when the driver's seat is adjusted to its most vertical and rearward position.
- 3.23. "Striker" is a device with which the latch engages to maintain the door in the fully latched or secondary latched position.

3.24. "Trunk Lid" is a movable body panel that provides access from outside the vehicle to a space wholly partitioned from the occupant compartment by a permanently attached partition or fixed or fold-down seat back.

4. General Requirements

4.1. The requirements apply to all side and back doors and door components except for those on folding doors, roll-up doors, detachable doors, and doors that are designated to provide emergency egress.

4.2. Door Latches

4.2.1. Each hinged door system shall be equipped with at least one primary door latch system.

4.2.2. Each sliding door system shall be equipped with either:

- a) a primary door latch system, or
- b) a door latch system with a fully latched position and a door closure warning system.

5. Performance Requirements

5.1. Hinged doors

5.1.1. Load Test One.

5.1.1.1 Each primary door latch system and auxiliary door latch system, when in the fully latched position, shall not separate when a load of 11,000 N is applied in the direction perpendicular to the face of the latch such that the latch and the striker anchorage are not compressed against each other, when tested in accordance with paragraph 7.1.1.1.

5.1.1.2. When in the secondary latched position, the primary latch system shall not separate when a load of 4,500 N is applied in the same direction as in paragraph 5.1.1.1, when tested in accordance with paragraph 7.1.1.1.

5.1.2. Load Test Two.

5.1.2.1 Each primary door latch system and auxiliary door latch system, when in the fully latched position, shall not separate when a load of 9,000 N is applied in the fork-bolt opening direction and parallel to the face of the latch, when tested in accordance with paragraph 7.1.1.1.

5.1.2.2. When in the secondary latched position, the primary latch system shall not separate when a load of 4,500 N is applied in the same direction, as in paragraph 5.1.2.1, when tested in accordance with paragraph 7.1.1.1.

- 5.1.3. Load Test Three.
 - 5.1.3.1. Each primary door latch system on back doors shall not disengage from the fully latched position when a load of 9,000 N is applied in a direction orthogonal to the directions specified in paragraphs 5.1.1.1 and 5.1.2.1., when tested in accordance with paragraph 7.1.1.1.
 - 5.1.4. Inertial Load. Each primary door latch system and auxiliary door latch system shall meet the dynamic requirements of either paragraph 5.1.4.1 and 5.1.4.2 or the calculation of inertial load resistance requirements of paragraph 5.1.4.3.
 - 5.1.4.1. Each primary door latch system and auxiliary door latch system on each hinged door shall not disengage from the fully latched position when an inertial load of 30 g is applied to the door latch system, including the latch and its activation device, in the directions parallel to the vehicle's longitudinal and transverse axes with the locking device disengaged and when demonstrated in accordance with paragraph 7.1.1.2.
 - 5.1.4.2. Each primary door latch system and auxiliary door latch system on each hinged back door shall also not disengage from the fully latched position when an inertial load of 30 g is applied to the door latch system, including the latch and its activation device, in the direction parallel to the vehicle's vertical axis, with the locking device disengaged and when demonstrated in accordance with paragraph 7.1.1.2.
 - 5.1.4.3. Each component or subassembly can be calculated for its minimum inertial load resistance in a particular direction. The combined resistance to the unlatching operation must assure that the door latch system, when properly assembled in the vehicle door, will remain latched when subjected to an inertial load of 30 g in the vehicle directions specified in paragraphs 5.1.4.1 and 5.1.4.2, as applicable, in accordance with paragraph 7.1.1.2.
 - 5.1.5. Door Hinges
 - 5.1.5.1. Each door hinge system shall:
 - (a) Support the door,
 - (b) Not separate when a longitudinal load of 11,000 N is applied,
 - (c) Not separate when a transverse load of 9,000 N is applied, and
 - (d) On back doors only, not separate when a vertical load of 9,000 N is applied.
 - 5.1.5.2. All tests required by paragraph 5.1.5.1 are conducted in accordance with paragraph 7.1.2.
 - 5.1.5.3. If a single hinge within the hinge system is tested instead of the entire hinge system, the hinge must bear a load proportional to the total number of hinges in the hinge system.

- 5.1.5.4. On side doors with rear mounted hinges that can be operated independently of other doors,
- (a) The interior door handle shall be inoperative when the speed of the vehicle is greater than or equal to 4 km/h, and
 - (b) A door closure warning system shall be provided for those doors.
- 5.2. Sliding Side Doors
- 5.2.1. Load Test One.
- 5.2.1.1. At least one door latch system, when in the fully latched position, shall not separate when a load of 11,000 N is applied in the direction perpendicular to the face of the latch, when tested in accordance with paragraph 7.2.1.1.
- 5.2.1.2. In the case of a primary door latch system, when in the secondary latched position, the door latch system shall not separate when a load of 4,500 N is applied in the same direction as in paragraph 5.2.1.1, when tested in accordance with paragraph 7.2.1.1.
- 5.2.2. Load Test Two.
- 5.2.2.1. At least one door latch system, when in the fully latched position, shall not separate when a load of 9,000 N is applied in the direction of the fork-bolt opening and parallel to the face of the latch when tested in accordance with paragraph 7.2.1.1.
- 5.2.2.2. In the case of a primary door latch system, when in the secondary latched position, the primary latch system shall not separate when a load of 4,500 N is applied in the same direction as paragraph 5.2.2.1, when tested in accordance with paragraph 7.2.1.1.
- 5.2.3. Inertial Load. Each door latch system meeting the requirements of paragraphs 5.2.1 and 5.2.2 shall meet the dynamic requirements of either paragraph 5.2.3.1 or the calculation of inertial requirements of paragraph 5.2.3.2.
- 5.2.3.1. The door latch system shall not disengage from the fully latched position when an inertial load of 30 g is applied to the door latch system, including the latch and its activation device, in the directions parallel to the vehicle's longitudinal and transversal axes with the locking device disengaged and when tested in accordance with paragraph 7.2.1.2.
- 5.2.3.2. The minimum inertial load resistance can be calculated for each component or subassembly. Their combined resistance to the unlatching operation must assure that the door latch system, when properly assembled in the vehicle door, will remain latched when subjected to an inertial load of 30 g in the vehicle directions specified in paragraph 5.2.1 or 5.2.2, as applicable, in accordance with paragraph 7.2.1.2.

5.2.4. Door System

5.2.4.1. The track and slide combination or other supporting means for each sliding door, while in the closed fully latched position, shall not separate from the door frame when a total force of 18,000 N along the vehicle transverse axis is applied to the door in accordance with paragraph 7.2.2.

5.2.4.2. The sliding door, when tested in accordance with paragraph 7.2.2, fails this requirement if any one of the following occurs:

5.2.4.2.1 A separation between the interior of the door and the exterior edge of the doorframe exceeds 100 mm, while the required force is maintained.

5.2.4.2.2 Either force application device reaches a total displacement of 300 mm.

5.3. Door Locks

5.3.1. Each door shall be equipped with at least one locking device which, when engaged, shall prevent operation of the exterior door handle or other exterior latch release control and which has an operating means and a lock release/engagement device located within the interior of the vehicle.

5.3.2. Rear side doors. Each rear side door shall be equipped with at least one locking device which, when engaged, prevents operation of the interior door handle or other interior latch release control and requires separate actions to unlock the door and operate the interior door handle or other interior latch release control.

5.3.2.1. Based on a determination by each contracting party or regional economic integration organization, the locking device may be a:

(a) child safety lock system, or

(b) lock release/engagement device located within the interior of the vehicle and readily accessible to the driver of the vehicle or an occupant seated adjacent to the door.

5.3.2.2. Either system described in paragraph 5.3.2.1 (a) and (b) shall be permitted as an additional locking feature.

5.3.3. Back doors. Each back door equipped with an interior door handle or other interior latch release control, shall be equipped with at least one locking device located within the interior of the vehicle which, when engaged, prevents operation of the interior door handle or other interior latch release control and requires separate actions to unlock the door and operate the interior door handle or other interior latch release control.

6. Test Conditions

(Reserved)

- 7. Test Procedure
- 7.1. Hinged Doors
 - 7.1.1. Door Latches
 - 7.1.1.1. Load Test One, Two, and Three Force Application. Compliance with paragraphs 5.1.1., 5.1.2. and 5.1.3. is demonstrated in accordance with annex 1.
 - 7.1.1.2. Inertial Force Application. Compliance with paragraph 5.1.4. is demonstrated in accordance with annex 2.
 - 7.1.2. Door Hinges. Compliance with paragraph 5.1.5. is demonstrated in accordance with annex 3.
- 7.2. Sliding Side Doors.
 - 7.2.1. Door Latches
 - 7.2.1.1. Load Test one and Two Force Application. Compliance with paragraphs 5.2.1. and 5.2.2., is demonstrated in accordance with annex 1.
 - 7.2.1.2. Inertial Force Application. Compliance with paragraph 5.2.3. is demonstrated in accordance with annex 2.
 - 7.2.2. Door System. Compliance with paragraph 5.2.4. is demonstrated in accordance with annex 4.

Annex 1

Latch Test for Load Test One, Two, and Three Force Applications

1. Purpose. These tests are intended to establish minimum performance requirements and test procedures for evaluating and testing vehicle door latch systems for their ability to resist force loads in directions perpendicular to the latch face and parallel to the latch face in the fork-bolt opening direction. For back doors only, the tests are intended to also establish minimum performance requirements and a test procedure for evaluating the primary latch system in a direction orthogonal to the first two directions. Primary door latch systems must demonstrate the ability to resist applicable force loads in both the fully and secondary latched positions; auxiliary door latch systems, and other door latch systems with only a fully-latched position, must demonstrate the ability to resist force loads in directions perpendicular to the latch face and parallel to the latch face in the fork-bolt opening direction at the levels specified for the fully latched position.
2. Test Operation
 - 2.1. Load Test One
 - 2.1.1. Equipment. Tensile testing fixture (see Figure 1-1).
 - 2.1.2. Procedures
 - 2.1.2.1. Fully Latched Position
 - 2.1.2.1.1. Adapt the test fixture to the mounting provisions of the latch and striker. Align the direction of engagement parallel to the linkage of the fixture. Mount the latch and striker in the fully latched position to the test fixture.
 - 2.1.2.1.2. Locate weights to apply a 900 N load tending to separate the latch and striker in the direction of the door opening.
 - 2.1.2.1.3. Apply the test load, in the direction specified in paragraph 5.1.1 of this regulation and Figure 1-4, at a rate not to exceed 5 mm/min until the required load has been achieved. Record the maximum load achieved.
 - 2.1.2.2. Secondary Latched Position
 - 2.1.2.2.1. Adapt the test fixture to the mounting provisions of the latch and striker. Align the direction of engagement parallel to the linkage of the fixture. Mount the latch and striker in the secondary latched position to the test fixture.
 - 2.1.2.2.2. Locate weights to apply a 900 N load tending to separate the latch and striker in the direction of the door opening.

- 2.1.2.2.3. Apply the test load, in the direction specified in paragraph 5.1.1 of this regulation and Figure 1-4, at a rate not to exceed 5 mm/min until the required load has been achieved. Record the maximum load achieved.
- 2.1.2.2.4. The test plate on which the door latch is mounted will have a striker cut-out configuration similar to the environment in which the door latch will be mounted on normal vehicle doors.
- 2.2. Load Test Two
 - 2.2.1. Equipment. Tensile testing fixture (see Figure 1-2).
 - 2.2.2. Procedures
 - 2.2.2.1. Fully Latched Position
 - 2.2.2.1.1. Adapt the test fixture to the mounting provisions of the latch and striker. Mount the latch and striker in the fully latched position to the test fixture.
 - 2.2.2.1.2. Apply the test load, in the direction specified in paragraph 5.1.2 of this regulation and Figure 1-4, at a rate not to exceed 5 mm/min until the required load has been achieved. Record the maximum load achieved.
 - 2.2.2.2. Secondary Latched Position
 - 2.2.2.2.1. Adapt the test fixture to the mounting provisions of the latch and striker. Mount the latch and striker in the secondary latched position to the test fixture.
 - 2.2.2.2.2. Apply the test load, in the direction specified in paragraph 5.1.2 of this regulation and Figure 1-4, at a rate not to exceed 5 mm/min until the required load has been achieved. Record the maximum load achieved.
- 2.3. Load Test Three (Back Doors Only)
 - 2.3.1. Equipment. Tensile testing fixture (see Figure 1-3).
 - 2.3.2. Procedure
 - 2.3.2.1. Adapt the test fixture to the mounting provisions of the latch and striker. Mount the latch and striker in the fully latched position to the test fixture.
 - 2.3.2.2. Apply the test load, in the direction specified in paragraph 5.1.3 of this regulation and Figure 1-4, at a rate not to exceed 5 mm/min until the required load has been achieved. Record the maximum load achieved.

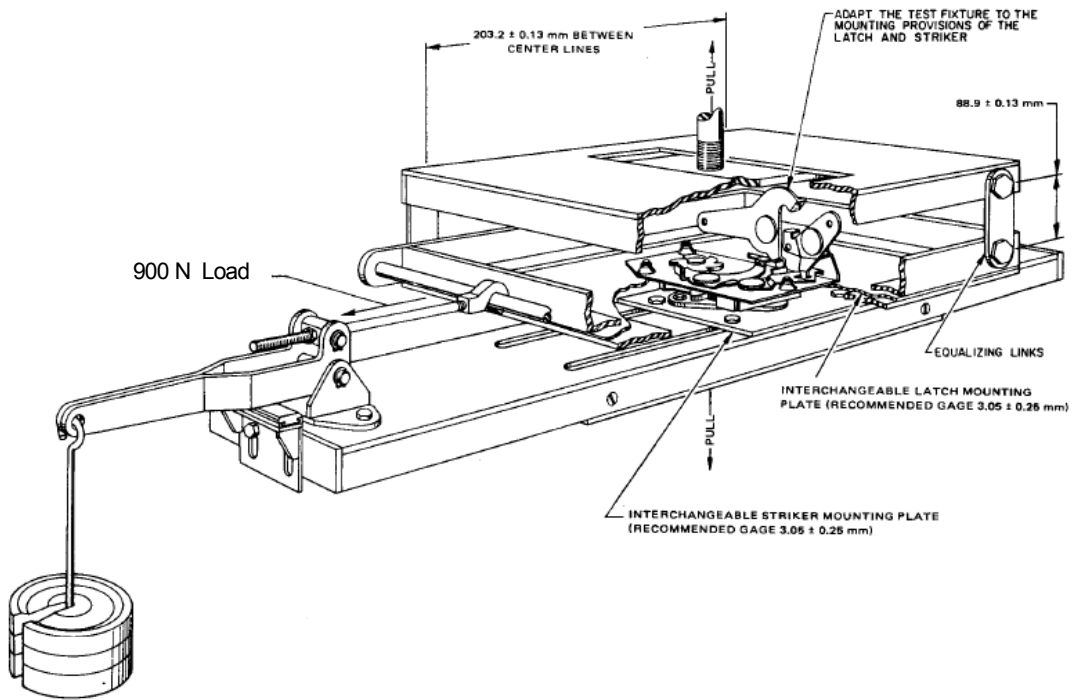

Figure 1-1 – Door Latch - Tensile Testing Fixture for Load Test 1

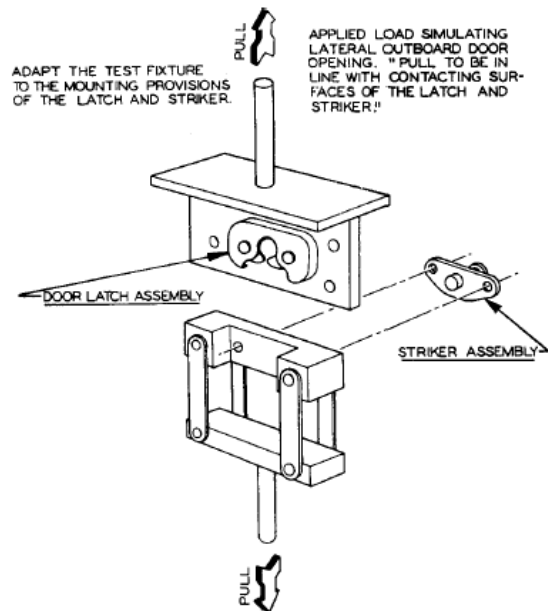

Figure 1-2 – Door Latch – Tensile Testing Fixture for Load Test 2

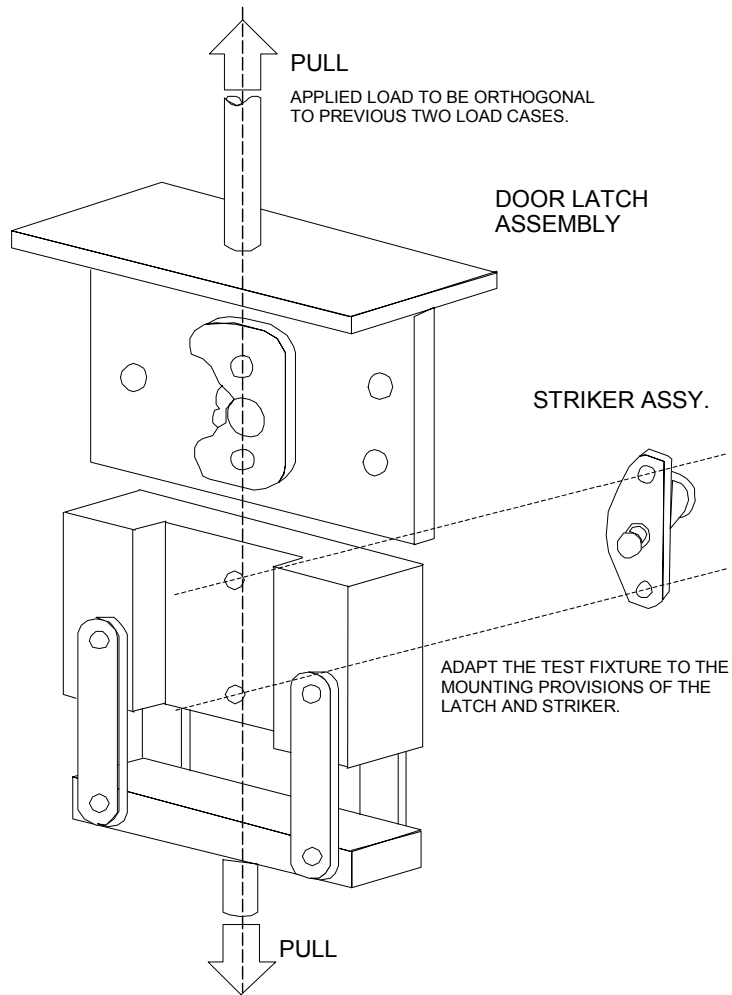

Figure 1-3 - Door Latch – Tensile Testing Fixture for Load Test 3 (Back Doors Only)

DOOR LATCH STATIC LOAD TEST DIRECTIONS

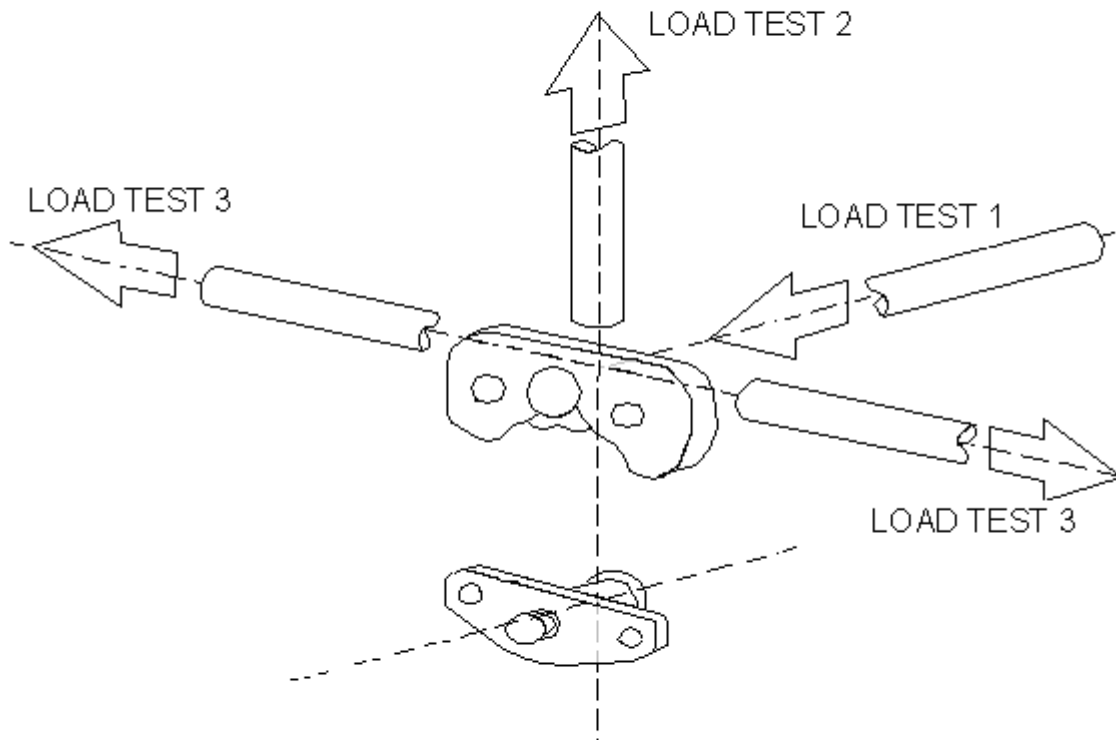

Figure 1-4 – Door Static Load Test Directions

Annex 2

Inertial Test Procedures

1. Purpose. To determine the ability of the vehicle latch system to resist inertial loading by means of a mathematical analysis of the component parts in their true car relationship or by evaluation using a dynamic test.
2. Test Procedures
 - 2.1 Option 1, Calculation
 - 2.1.1. The procedure described in this section provides a means for analytically determining the ability of a door latch system to withstand inertial loading. Spring forces are the average of the minimum spring output in the installed position and the minimum spring output in the release position. Friction effects and work to be done are not considered in the calculations. Gravitational pull on components may also be omitted if it tends to restrict unlatching. These omissions from the calculations are permissible because they provide additional factors of safety.
 - 2.1.2. Calculation Consideration—Each component or subassembly can be calculated for its minimum inertial load resistance in a particular direction. Their combined resistance to the unlatching operation must assure that the door latch system (when properly assembled in the vehicle door) will remain latched when subjected to an inertial load of 30 g in any direction. Figure 2-1 is an example of the components and combinations of components to be considered.
 - 2.2 Option 2, Full Vehicle Dynamic Test
 - 2.2.1 Test Equipment
 - 2.2.1.1 An acceleration (or deceleration) device.
 - 2.2.1.2 One of the following vehicles:
 - 2.2.1.2.1 A full vehicle including at least door(s), door latch(es), exterior door handle(s) with mechanical latch operation, interior door opening lever(s), the locking device(s), interior trim and door seal.
 - 2.2.1.2.2 A vehicle body in white (i.e., vehicle frame, doors and other door retention components) including at least door(s), door latch(es), exterior door handle(s) with mechanical latch operation, interior door opening lever(s), and the locking device(s)

- 2.2.1.3 A device or means for recording door opening¹.
- 2.2.1.4 Equipment for measuring and recording accelerations.
- 2.2.2 Test Setup
 - 2.2.2.1. Rigidly secure the full vehicle or vehicle body in white to a device that when accelerated together will assure that all points on the crash pulse curve are within the corridor defined in Table 2-1 and Figure 2-2.
 - 2.2.2.2 The doors may be tethered to avoid damaging the equipment used to record door opening.
 - 2.2.2.3 Install the equipment used to record door opening.
 - 2.2.2.4 Close the door(s) to be tested and ensure that the door latch(es) are in the fully-latched position, that the door(s) are unlocked, and that all windows, if provided, are closed.
- 2.2.3 Test Directions (see Figure 2-3)
 - 2.2.3.1 Longitudinal Setup 1. Orient the vehicle or body in white so that its longitudinal axis is aligned with the axis of the acceleration device, simulating a frontal impact.
 - 2.2.3.2 Longitudinal Setup 2. Orient the vehicle or body in white so that its longitudinal axis is aligned with the axis of the acceleration device, simulating a rear impact.
 - 2.2.3.3 Transverse Setup 1. Orient the vehicle or body in white so that its transverse axis is aligned with the axis of the acceleration device, simulating a driver-side impact.
 - 2.2.3.4 Transverse Setup 2 (Only for vehicles having different door arrangements on each side). Orient the vehicle or body in white so that its transverse axis is aligned with the axis of the acceleration device, simulating a side impact in the direction opposite to that described in paragraph 2.2.3.3.
- 2.3 Option 3, Door Dynamic Test
 - 2.3.1 Test Equipment

¹ The purpose of this device is to ensure that door opening is recorded if a door opens and re-closes during the test.

- 2.3.1.1 The door assembly(ies) including, at least, the door latch(es), exterior door handle(s) with mechanical latch operation, interior door opening lever(s), and the locking device(s)
- 2.3.1.2 A test fixture to mount the door(s).
- 2.3.1.3 An acceleration (or deceleration) device.
- 2.3.1.4 A tether.
- 2.3.1.5 A device or means for recording door opening¹.
- 2.3.1.6 Equipment for measuring and recording accelerations.
- 2.3.2 Test Setup
 - 2.3.2.1 Mount the door assemblies either separately or combined to the test fixture. Each door and striker should be mounted to correspond to its orientation on the vehicle and to the direction required for inertial load tests (see paragraph 2.3.3).
 - 2.3.2.2 Mount the test fixture to the acceleration device.
 - 2.3.2.3 Install the equipment used to record door opening.
 - 2.3.2.4 Ensure that the door latch is in the fully-latched position, that the door is tethered, unlocked, and that the window, if provided, is closed.
- 2.3.3 Test Directions (see Figure 2-3)
 - 2.3.3.1 Longitudinal Setup 1. Orient the door subsystem(s) on the acceleration device in the direction of a frontal impact.
 - 2.3.3.2 Longitudinal Setup 2. Orient the door subsystem(s) on the acceleration device in the direction of a rear impact.
 - 2.3.3.3 Transverse Setup 1. Orient the door subsystem(s) on the acceleration device in the direction of a driver-side impact.
 - 2.3.3.4 Transverse Setup 2. Orient the door subsystem(s) on the acceleration device in the direction opposite to that described in paragraph 2.3.3.3.
 - 2.3.3.5 Vertical Setup 1. (Only for back doors). Orient the door subsystem(s) on the acceleration device so that its vertical axis (when mounted in a vehicle) is aligned with the axis of the acceleration device, simulating a rollover impact

where the force is applied in the direction from the top to the bottom of the door (when mounted in a vehicle).

- 2.3.3.6 Vertical Setup 2. (Only for back doors). Orient the door subsystem(s) on the acceleration device so that its vertical axis (when mounted in a vehicle) is aligned with the axis of the acceleration device, simulating a rollover impact where the force is applied in the direction opposite to that described in paragraph 2.3.3.5.
- 2.4 Test Operation for Options 2 and 3
 - 2.4.1 A minimum acceleration level of 30g shall be maintained over a period of at least 30 ms, while keeping the acceleration within the pulse corridor as defined in Table 2-1 and graphically shown in Figure 2-2.
 - 2.4.2 Accelerate the test fixture(s) in the following directions:
 - 2.4.2.1 For Option 2 tests:
 - 2.4.2.1.1 In the direction specified in paragraph 2.2.3.1.
 - 2.4.2.1.2 In the direction specified in paragraph 2.2.3.2.
 - 2.4.2.1.3 In the direction specified in paragraph 2.2.3.3.
 - 2.4.2.1.4 In the direction specified in paragraph 2.2.3.4.
 - 2.4.2.2 For Option 3 tests:
 - 2.4.2.2.1 In the direction specified in paragraph 2.3.3.1.
 - 2.4.2.2.2 In the direction specified in paragraph 2.3.3.2.
 - 2.4.2.2.3 In the direction specified in paragraph 2.3.3.3.
 - 2.4.2.2.4 In the direction specified in paragraph 2.3.3.4.
 - 2.4.2.2.5 In the direction specified in paragraph 2.3.3.5.
 - 2.4.2.2.6 In the direction specified in paragraph 2.3.3.6.
 - 2.4.3 If at any point in time the pulse exceeds 36g and the test requirements are fulfilled, the test shall be considered valid.
 - 2.4.4 Ensure that the door did not open and close during the test.

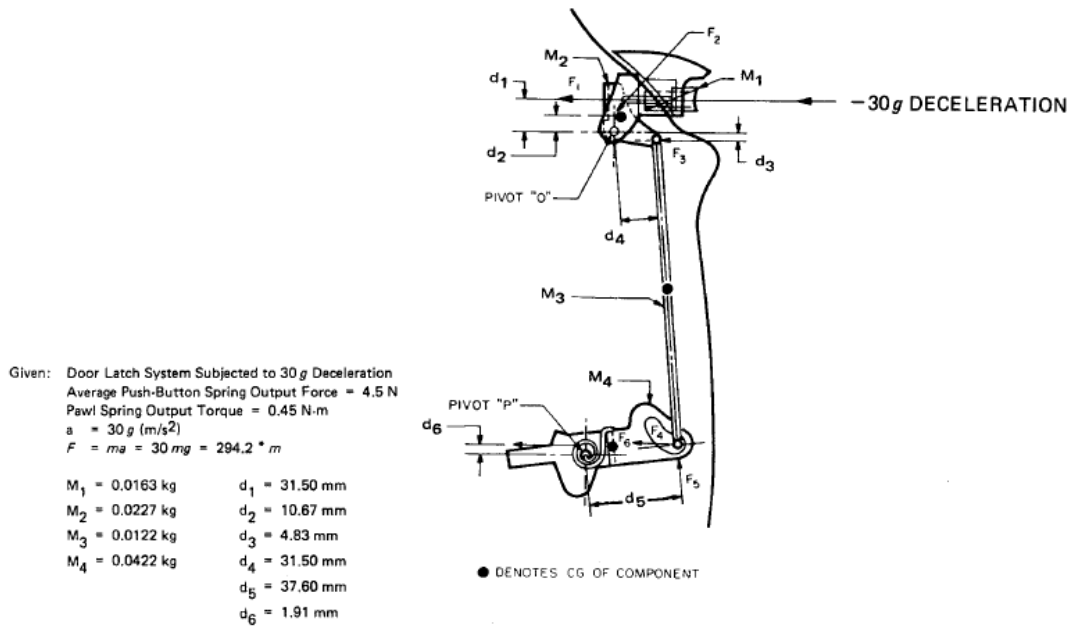

$$F_1 = M_1 a - (\text{avg. spring output}) = (0.0163 \times 294.2) - 4.5 = 0.30 \text{ N}$$

$$F_2 = M_2 a = 0.0227 \times 294.2 = 6.68 \text{ N}$$

$$F_3 = \frac{M_3 a}{2} = (0.0122/2) \times 294.2 = 1.80 \text{ N}$$

$$\Sigma M_o = F_1 \times d_1 + F_2 d_2 - F_3 d_3 = 0.30 \times 31.5 + 6.68 \times 10.67 - 1.80 \times 4.83 = 72.0 \text{ N-mm}$$

$$F_5 = \frac{M_o}{d_4} = \frac{72.0}{31.50} = 2.30 \text{ N}$$

$$F_6 = M_4 a = 0.0422 \times 294.2 = 12.42 \text{ N}$$

$$\Sigma M_p = (\text{pawl spring output}) - \left(\frac{F_5 \times d_5 + F_6 \times d_6}{1000} \right) = 0.45 - \left(\frac{2.30 \times 37.60 + 12.42 \times 1.91}{1000} \right) = 0.34 \text{ N-m}$$

EQUATIONS		METRIC UNITS	
SYMBOL	DEFINITION	SYMBOL	DEFINITION
m	Mass	kg	Kilogram
a	Acceleration	m/s ²	Meter per second squared
g	Gravitational Acceleration	m/s ²	9 806 650 Meter per second squared
d	Distance to Pivot	mm	Millimeter
F	Force	N	Newton
M	Moment About a Point	N-m	Newton Meter (preferred)
		N-mm	(Newton-Millimeter)

Figure 2-1 – Inertial Loading – Sample Calculation

Upper Bound			Lower Bound		
Point	Time (ms)	Acceleration (g)	Point	Time (ms)	Acceleration (g)
A	0	6	E	5	0
B	20	36	F	25	30
C	60	36	G	55	30
D	100	0	H	70	0

Table 2-1 – Acceleration Pulse Corridor

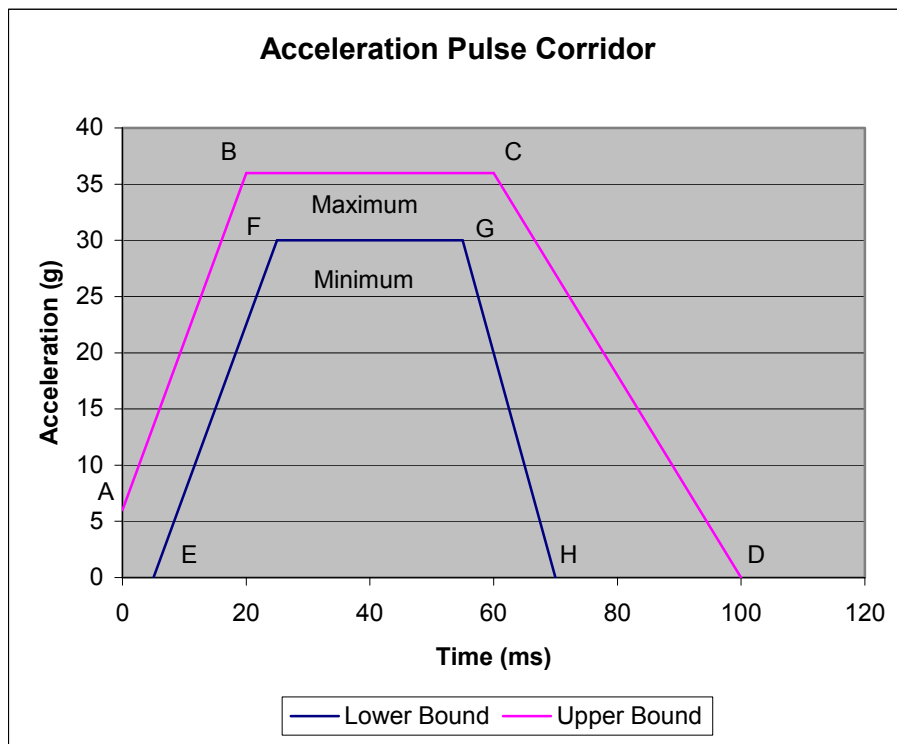
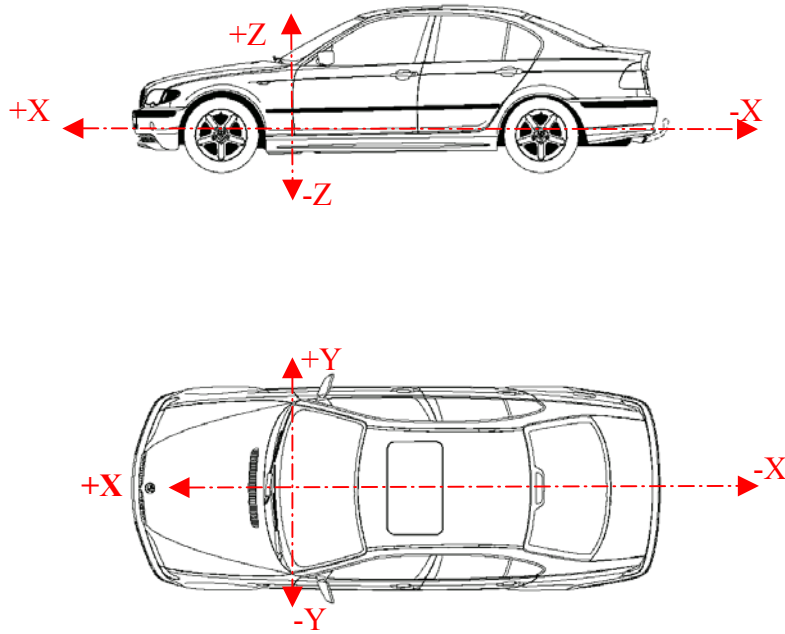

Figure 2-2 – Acceleration Pulse



X = **longitudinal direction**
Y = **transversal direction**
Z = **vertical direction**

Figure 2-3 - Vehicle Coordinate Reference System for Inertial Testing

Annex 3

Hinge Test Procedure

1. Purpose. These tests are conducted to determine the ability of the vehicle hinge system to withstand test loads in the longitudinal, transversal, and, for back doors only, vertical vehicle directions.
2. Test Procedure
 - 2.1. Multiple Hinge System
 - 2.1.1. Longitudinal Load Test
 - 2.1.1.1. Equipment
 - 2.1.1.1.1. Tensile testing fixture
 - 2.1.1.1.2. A typical static test fixture is illustrated in Figure 3-1.
 - 2.1.1.2. Procedure
 - 2.1.1.2.1. Attach the hinge system to the mounting provision of the test fixture. Hinge attitude must simulate vehicle position (door fully closed) relative to the hinge centreline. For test purposes, the distance between the extreme ends of one hinge in the system to the extreme end of another hinge in the system is to be set at 406 ± 4 mm. The load is to be applied equidistant between the linear centre of the engaged portions of the hinge pin and through the centreline of the hinge pin in the longitudinal vehicle direction (Figure 3-2).
 - 2.1.1.2.2. Apply the test load at a rate not to exceed 5 mm/min until the required load has been achieved. Failure consists of a separation of either hinge. Record the maximum load achieved.
 - 2.1.2. Transverse Load Test
 - 2.1.2.1. Equipment
 - 2.1.2.1.1. Tensile testing fixture
 - 2.1.2.1.2. A typical static test fixture is illustrated in Figure 3-1.
 - 2.1.2.2. Procedure
 - 2.1.2.2.1. Attach the hinge system to the mounting provisions of the test fixture. Hinge attitude must simulate vehicle position (door fully closed) relative to the hinge

centreline. For test purposes, the distance between the extreme ends of one hinge in the system to the extreme opposite end of another hinge in the system is to be set at 406 ± 4 mm. The load is to be applied equidistant between the linear centre of the engaged portions of the hinge pins and through the centreline of the hinge pin in the transverse vehicle direction (Figure 3-2).

2.1.3.2.2 Apply the test load at a rate not to exceed 5 mm/min until the required load has been achieved. Failure consists of a separation of either hinge. Record the maximum load achieved.

2.1.3. Vertical Load Test (Backdoors Only)

2.1.3.1. Equipment

2.1.3.1.1. Tensile testing fixture

2.1.3.1.2. A typical static test fixture is illustrated in Figure 3-1.

2.1.3.2 Procedure

2.1.3.2.1 Attach the hinge system to the mounting provisions of the test fixture. Hinge attitude must simulate vehicle position (door fully closed) relative to the hinge centreline. For test purposes, the distance between the extreme ends of one hinge in the system to the extreme opposite end of another hinge in the system is to be set at 406 ± 4 mm. The load is to be applied through the centerline of the hinge pin in a direction orthogonal to the longitudinal and transverse loads (Figure 3-2).

2.1.3.2.2 Apply the test load at a rate not to exceed 5 mm/min until the required load has been achieved. Failure consists of a separation of either hinge. Record the maximum load achieved.

2.2. Single Hinge Evaluation. In some circumstances, it may be necessary to test the individual hinges of a hinge system. In such cases, the results for an individual hinge, when tested in accordance with the procedures below, shall be such as to indicate that system requirements in paragraph 5.1.5.1 of this regulation are met. (For example, an individual hinge in a two-hinge system must be capable of withstanding 50 percent of the load requirements of the total system.)

2.2.1. Test Procedures

2.2.1.1. Longitudinal Load. Attach the hinge system to the mounting provision of the test fixture. Hinge attitude must simulate the vehicle position (door fully closed) relative to the hinge centreline. For test purposes, the load is to be applied equidistant between the linear centre of the engaged portions of the

hinge pin and through the centreline of the hinge pin in the longitudinal vehicle direction. Apply the test load at a rate not to exceed 5 mm/min until the required load has been achieved. Failure consists of a separation of either hinge. Record the maximum load achieved.

- 2.2.1.2. Transverse Load. Attach the hinge system to the mounting provision of the test fixture. Hinge attitude must simulate the vehicle position (door fully closed) relative to the hinge centreline. For test purposes, the load is to be applied equidistant between the linear centre of the engaged positions of the hinge pin and through the centreline of the hinge pin in the transverse vehicle direction. Apply the test load at a rate not to exceed 5 mm/min until the required load is achieved. Failure consists of a separation of either hinge. Record the maximum load achieved.
- 2.2.1.3. Vertical Load. Attach the hinge system to the mounting provision of the test fixture. Hinge attitude must simulate the vehicle position (door fully closed) relative to the hinge centreline. For test purposes, the load is to be applied centerline of the hinge pin in a direction orthogonal to the longitudinal and transverse loads. Apply the test load at a rate not to exceed 5 mm/min until the required load is achieved. Failure consists of a separation of either hinge. Record the maximum load achieved.
- 2.3. For piano-type hinges, the hinge spacing requirements are not applicable and arrangement of the test fixture is altered so that the test forces are applied to the complete hinge.

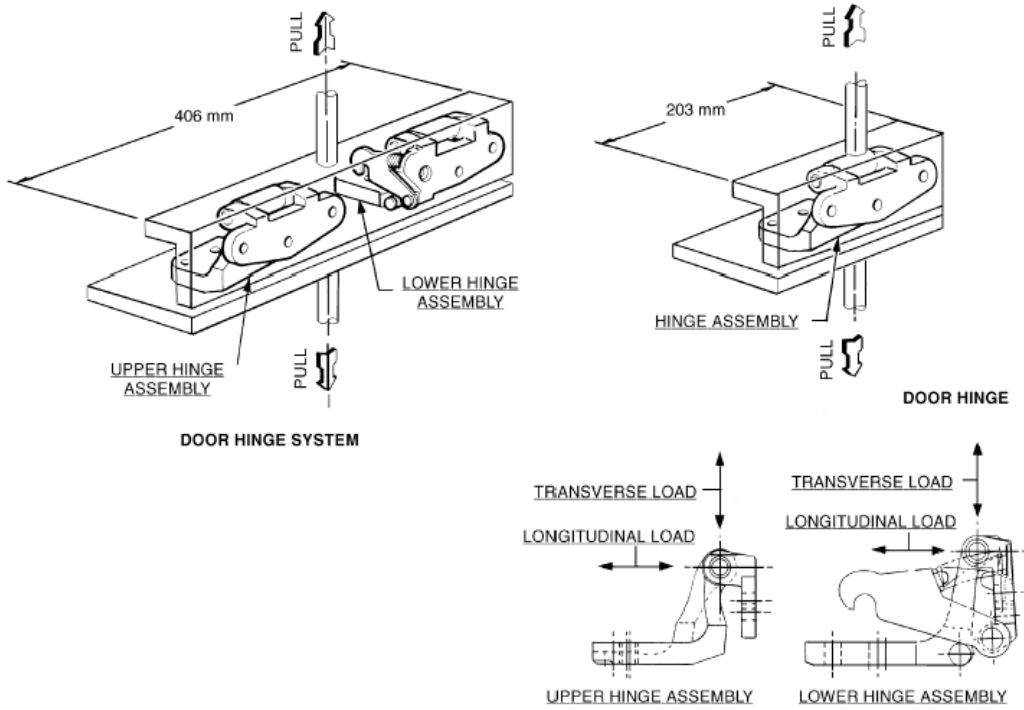

Figure 3-1 – Static load fixtures

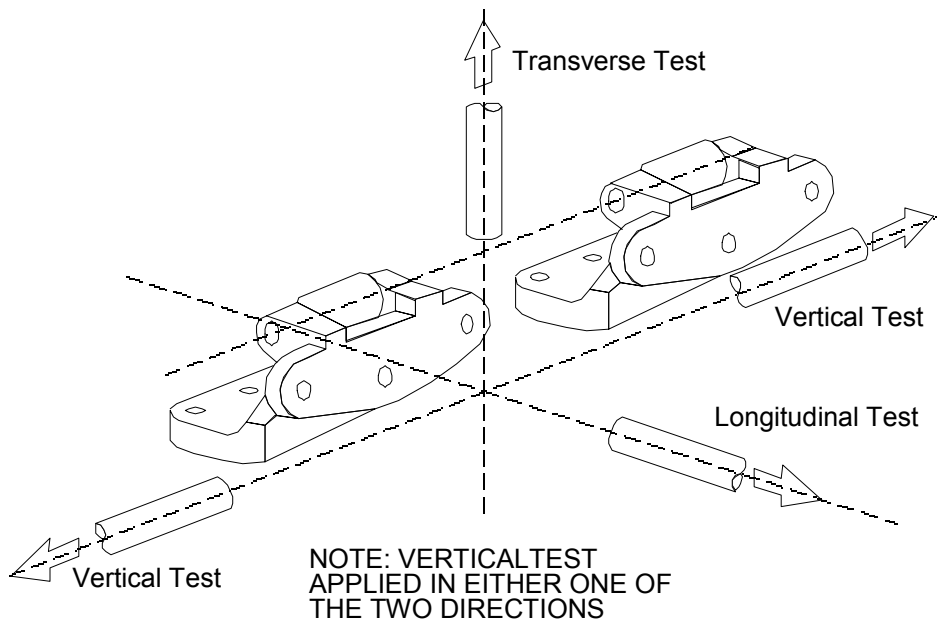

Figure 3-2 – Static load test directions for back doors

Annex 4
Sliding Side Door
Full Door Test

1. Purpose. This test is intended to establish minimum performance requirements and a test procedure for evaluation and testing sliding door retention components when installed on both the door and the doorframe. This test complements the applicable tests in Annex 1 and Annex 2
2. General Provisions
 - 2.1. Tests are conducted using a full vehicle or a body in white with the sliding door and its retention components.
 - 2.2. The test is conducted using two force application devices capable of applying the outward transverse forces specified in paragraph 5.2.4 of this regulation. The test setup is shown in Figure 4-1. The force application system shall include the following:
 - 2.2.1 Two force application plates.
 - 2.2.2 Two force application devices capable of applying the outward transverse load requirements for a minimum displacement of 300 mm.
 - 2.2.3. Two load cells of sufficient capacity to measure the applied loads.
 - 2.2.4. Two linear displacement measurement devices required for measuring force application device displacement during the test.
 - 2.2.5 Equipment for measuring at least 100 mm of separation between the interior of the door and the exterior edge of the doorframe, while respecting all relevant safety and health requirements.
3. Test Setup
 - 3.1. Remove all interior trim and decorative components from the sliding door assembly.
 - 3.2. Remove seats and any interior components that may interfere with the mounting and operation of the test equipment.
 - 3.3. Mount the force application devices and associated support structure to the floor of the test vehicle.
 - 3.4. Determine the forward and aft edge of the sliding door, or its adjoining vehicle structure, that contains a latch/striker.

- 3.5. Close the sliding door, ensuring that all door retention components are fully engaged.
- 3.6. For any tested door edge that contains one latch/striker, the following set-up procedures are used:
 - 3.6.1. The force application plate is 150 mm in length, 50 mm in width, and at least 15 mm in thickness.
 - 3.6.2. Place the force application device and force application plate against the door so that the applied force is horizontal and normal to the vehicle's longitudinal centreline, and vertically centred on the door-mounted portion of the latch/striker.
 - 3.6.3. The force application plate is positioned as close to the edge of the door as possible. It is not necessary for the force application plate to be vertical.
- 3.7. For any tested door edge that contains more than one latch/striker, the following set-up procedures are used:
 - 3.7.1. The force application plate is 300 mm in length, 50 mm in width, and at least 15 mm in thickness.
 - 3.7.2. Place the force application device and force application plate against the door so that the applied force is horizontal and normal to the vehicle's longitudinal centreline, and vertically centred on a point mid-way between the outermost edges of the latch/striker assemblies.
 - 3.7.3. The force application plate is positioned as close to the edge of the door as possible. It is not necessary for the force application plate to be vertical.
- 3.8. For any tested door edge that does not contain at least one latch/striker, the following set-up procedures are used:
 - 3.8.1. The force application plate is 300 mm in length, 50 mm in width, and at least 15 mm in thickness.
 - 3.8.2. Place the force application device and force application plate against the door so that the applied force is horizontal and normal to the vehicle's longitudinal centreline, and vertically centred on a point mid-way along the length of the door edge ensuring that the loading device avoids contact with the window glazing.
 - 3.8.3. The force application plate is positioned as close to the edge of the door as possible. It is not necessary for the force application plate to be vertical.

- 3.9. The door is unlocked. No extra fixtures or components may be welded or affixed to the sliding side door or any of its components.
- 3.10. Attach any equipment used for measuring door separation that will be used to determine separation levels during the test procedure.
- 3.11. Place the load application structure so that the force application plates are in contact with the interior of the sliding door.
4. Test Procedure
 - 4.1. Move each force application device at a rate of 20-90 mm per minute, as specified by the manufacturer, until a force of 9,000 N is achieved on each force application device or until either force application device reaches a total displacement of 300 mm.
 - 4.2. If one of the force application devices reaches the target force of 9,000 N prior to the other, maintain the 9,000 N force with that force application device until the second force application device reaches the 9,000 N force.
 - 4.3. Once both force application devices have achieved 9,000 N each, stop forward movement of the force application devices and hold under the resulting load for a minimum of 10 seconds.
 - 4.4. Maintain the force application device position in 4.3. and measure the separation between the exterior edge of the doorframe and the interior of the door along the perimeter of the door.

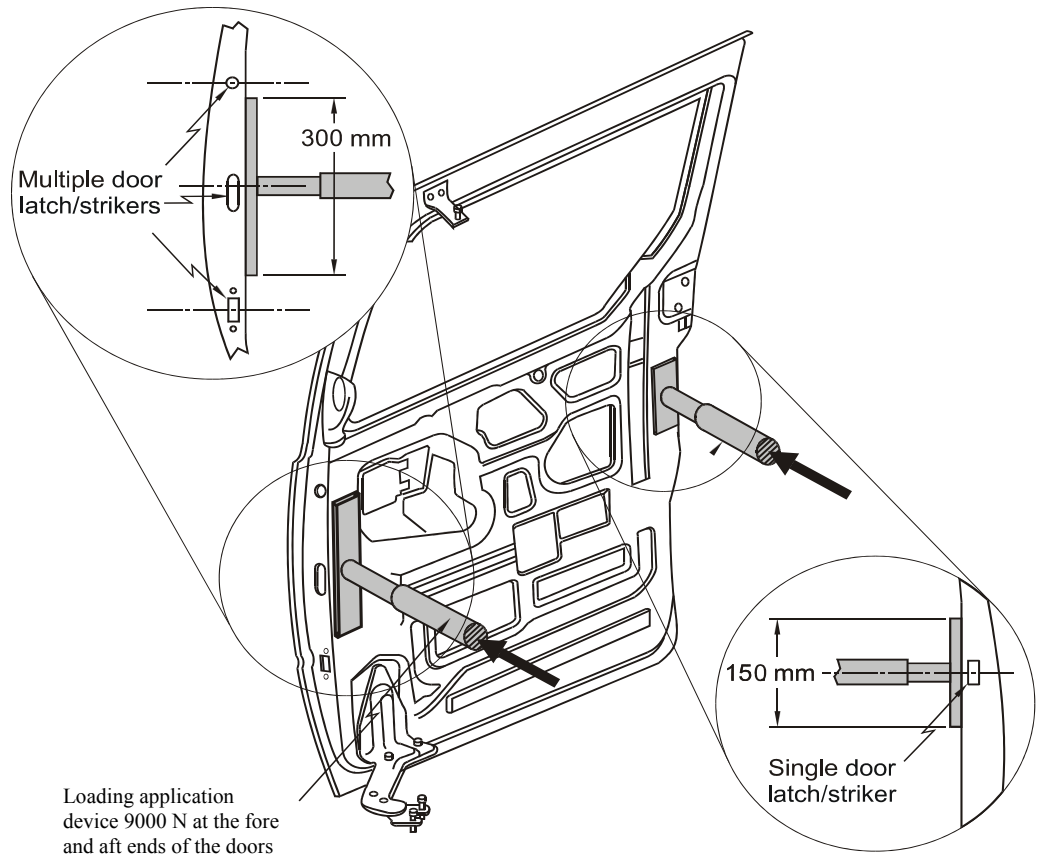

Figure 4-1 – Sliding Side Door Full Vehicle Test Procedure
 (Note: Sliding door is shown separated from the vehicle)

Annex 5
Vehicle Category Definitions

1. Definitions

- 1.1. "Complete Vehicle" means any vehicle which does not require further construction stages in order to be fit for the purpose for which it has been designed and constructed, other than minor finishing operations such as painting.
- 1.2. "Driver Mass" means the nominal mass of a driver that shall be 75 kg (subdivided into 68 kg occupant mass at the seat and 7 kg luggage mass in accordance with ISO standard 2416:1992).
- 1.3. "Gross vehicle mass" of a vehicle means the maximum mass of the fully laden solo vehicle, based on its construction and design performances, as declared by the manufacturer. This shall be less than or equal to the sum of the maximum axles' (group of axles) capacity.
- 1.4. "Mass in running order" means the nominal mass of a vehicle as determined by the following criteria:

Sum of unladen vehicle mass and driver's mass. The driver's mass is applied in accordance with paragraph 1.2.

In the case of category 1-2 vehicles, additional crewmembers for which seating positions are provided shall be included, their mass being equal to, and incorporated in the same way as, that of the driver.

- 1.5. "Maximum axle (group of axles) capacity" means the permissible mass corresponding to the maximum mass to be carried by the axle (group of axles) as defined by the vehicle manufacturer, not exceeding the axle manufacturer's specifications. The maximum axle (group of axles) capacity shall be less than or equal to the sum of the maximum capacities of the tyres.
- 1.6. "Maximum tyre capacity" means the permissible mass corresponding to the maximum mass to be carried by the tyre as defined by the vehicle manufacturer, not exceeding the tyre manufacturer's specifications.
- 1.7. "Passenger mass" means the nominal mass of a passenger that shall be 68 kg except in the case of Category 1-1 vehicle, where each passenger must additionally have 7 kg provision for luggage which shall be located in the luggage compartment(s) in accordance with ISO standard 2416:1992.
- in the case of category 1-2 vehicles not designed to carry standing passengers, where each passenger must have 3 kg additional provision for hand baggage.

- 1.8. "Pay mass" means the goods-carrying capacity of the vehicle which is the figure obtained by subtracting the unladen vehicle mass and the driver and passenger masses from the gross vehicle mass.
- 1.9. "Power driven vehicle" means any self-propelled vehicle designed and constructed to be used on the road and having at least two wheels.
- 1.10. "Trailer" means any non-self propelled vehicle, which is designed and constructed to be towed by a power driven vehicle.
- 1.11. "Unladen Vehicle Mass" means the nominal mass of a complete vehicle as determined by the following criteria:
- 1.11.1. Mass of the vehicle with bodywork and all factory fitted equipment, electrical and auxiliary equipment for normal operation of vehicle, including liquids, tools, fire extinguisher, standard spare parts, chocks and spare wheel, if fitted.
- 1.11.2. The fuel tank shall be filled to at least 90 per cent of rated capacity and the other liquid containing systems (except those for used water) to 100 per cent of the capacity specified by the manufacturer.
- 1.12. "Vehicle" means any power driven vehicle or trailer.
2. Categorization of Vehicles. For the purpose of this gtr, vehicles are classified on the basis of their design and construction features.
- 2.1. "Category 1 vehicle" means a power driven vehicle with four or more wheels designed and constructed primarily for the carriage of (a) person(s).
- 2.1.1. "Category 1-1 vehicle" means a category 1 vehicle comprising not more than eight seating positions in addition to the driver's seating position. A category 1-1 vehicle cannot have standing passengers.
- 2.1.2. "Category 1-2 vehicle" means a category 1 vehicle designed for the carriage of more than eight passengers, whether seated or standing, in addition to the driver.
- 2.2. "Category 2 vehicle" means a power driven vehicle with four or more wheels designed and constructed primarily for the carriage of goods. This category shall also include:
- i) tractive units
- ii) chassis designed specifically to be equipped with special equipment.
- 2.2.1. To determine whether a vehicle is to be regarded as a category 1 vehicle or a category 2 vehicle, the following shall apply in cases where it is not immediately apparent whether a vehicle is a category 1 or 2 vehicle:
- 2.2.2. If a vehicle meets all of the following conditions:
 $P - (M + N \times 68) > N \times 68$,

$N \leq 6$ and

Pay mass as defined in paragraph 1.8 exceeds 150 kg for the vehicle, as configured with the maximum mass of factory fitted optional equipment, the vehicle shall be deemed to be a category 2 vehicle. In all other cases, the vehicle shall be deemed to be a category 1 vehicle.

Where,

P= Gross vehicle mass

M= Mass in running order

N= Maximum number of simultaneous seating and standing positions excluding the driver seating position

- 2.2.2.1. If there is a seat anchor for a removable seat, the removable seat is to be counted in the determination of the number of seating positions and of the pay mass. Seating position means any individual seat or any part of a bench seat intended to seat one person.
- 2.2.2.2. Until the entry into force of a gtr on seats, Contracting Parties can use their own criteria to decide the number of seating positions.