

Distr.
GENERAL

TRANS/WP.29/GRSP/2002/18
30 September 2002

Original: ENGLISH

ECONOMIC COMMISSION FOR EUROPE

INLAND TRANSPORT COMMITTEE

World Forum for Harmonization of Vehicle Regulations (WP.29)

Working Party on Passive Safety (GRSP)
(Thirty-second session, 10-13 December 2002,
agenda item B.1.5.)

PROPOSAL FOR DRAFT 03 SERIES OF AMENDMENTS TO REGULATION No. 29
(Cabs of commercial vehicles)

Transmitted by the Expert from the United Kingdom

Note: The text reproduced below was prepared by the expert from the United Kingdom in order to consolidate all the proposals transmitted by the experts from the Czech Republic, Italy, the Russian Federation and the United Kingdom. Due to the extension of the amendments, the text has been prepared as a Revision of Regulation No. 29. When the proposals from different experts differ, the text includes all of them as options.

Note: This document is distributed to the Experts on Passive Safety only.

Regulation No. 29

UNIFORM PROVISIONS CONCERNING THE APPROVAL OF VEHICLES WITH REGARD TO THE
PROTECTION OF THE OCCUPANTS OF THE CAB OF A COMMERCIAL VEHICLE

1. SCOPE

[Option 1 (Existing)]

This Regulation applies to commercial vehicles which are intended for the carriage of goods. It does not apply to agricultural tractors and machinery.]

[Option 2

This Regulation applies to the motor vehicles of categories N2 and N3 with separate driver's cab. It does not apply to agricultural tractors and machinery."]

[Option 3

This Regulation applies to motor vehicles of category N1 (excluding vehicles with a total mass lower than 1500 kg), N2 and N3. It does not apply to agricultural tractors and machinery."]

[Option 4

This Regulation applied to commercial vehicles which are intended for the carriage of goods with a technically permitted maximum mass exceeding 2.5 tonnes. It does not apply to agricultural tractors and machinery.]

2. DEFINITIONS

For the purpose of this Regulation:

- 2.1. "approval of a vehicle" means the approval of vehicle type pursuant to the requirements of this Regulation, with regard to the protection of the occupants of the cab of a commercial vehicle in the event of a head-on impact, of overturning, or of shifting of the load;
- 2.2. "vehicle type" means a category of power-driven vehicles which do not differ in such essential respects as:
 - 2.2.1. The dimensions, shapes and materials of the components of the vehicle cab; or
 - 2.2.2. the manner of attachment of the cab to the chassis frame;
- 2.3. "transverse plane" means a vertical plane perpendicular to the median longitudinal plane of the vehicle;
- 2.4. "longitudinal plane" means a plane parallel to the median longitudinal plane of the vehicle.

3. APPLICATION FOR APPROVAL

3.1. The application for approval of a vehicle type with regard to the protection of the occupants of the cab of a commercial vehicle shall be submitted by the vehicle manufacture or by his duly accredited representative.

3.2. It shall be accompanied by drawings of the vehicles, showing the position of the cab on the vehicle and the manner of its attachment, and by sufficiently detailed drawings relating to the structure of the cab, all the said drawings being submitted in triplicate.

4. APPROVAL

4.1. If the vehicle type submitted for approval pursuant to this Regulation meets the requirements of paragraph 5. hereof, approval of the vehicle type shall be granted.

4.2. An approval number shall be assigned to each type approved. Its first two digits (at present 03 corresponding to the 03 series of amendments) shall indicate the series of amendments incorporating the most recent major technical amendments made to the Regulation at the time of issue of the approval. The same Contracting Party may not assign the same number to another vehicle type within the meaning of paragraph 2.2. above.

4.3. Notice of approval or of extension or of refusal or of withdrawal of approval or production definitely discontinued of a vehicle type pursuant to this Regulation shall be communicated to the Parties to the Agreement which apply this Regulation by means of a form conforming to the model in annex 1 to this Regulation.

4.4. There shall be affixed, conspicuously and in a readily accessible place specified on the approval form, to every vehicle conforming to a vehicle type approved under this Regulation an international approval mark consisting of:

- 4.4.1. a circle surrounding the letter "E" followed by the distinguishing number of the country which had granted approval; 1/
- 4.4.2. the number of this Regulation, followed by the letter "R", a dash and the approval number to the right of the circle prescribed in paragraph 4.4.1.; and
- 4.4.3. an additional symbol separated from the number of this Regulation by a vertical line and consisting of the letter "C" if the cab meets the requirements of test C.
- 4.5. If the vehicle conforms to a vehicle type approved, under one or more Regulations annexed to the Agreement, in the country which has granted approval under this Regulation, the symbol prescribed in paragraph 4.4.1. need not be repeated; in such a case the additional numbers and symbols of the Regulations under which approval has been granted in the country which has granted approval under this Regulation shall be placed in vertical columns to the right of the symbol prescribed in paragraph 4.4.1.
- 4.6. The approval mark shall be clearly legible and be indelible.
- 4.7. The approval mark shall be placed close to or on the vehicle data plated affixed by the manufacturer.
- 4.8. Annex 2 to this Regulation gives examples of arrangements of approval marks.

5. REQUIREMENTS

- 5.1. The cab of the vehicle shall be so designed and attached to the vehicle as to eliminate to the greatest possible extent the risk of injury to the occupants in the event of an accident.

1/ 1 for Germany, 2 for France, 3 for Italy, 4 for the Netherlands, 5 for Sweden, 6 for Belgium, 7 for Hungary, 8 for the Czech Republic, 9 for Spain, 10 for Yugoslavia, 11 for the United Kingdom, 12 for Austria, 13 for Luxembourg, 14 for Switzerland, 15 (vacant), 16 for Norway, 17 for Finland, 18 for Denmark, 19 for Romania, 20 for Poland, 21 for Portugal, 22 for the Russian Federation, 23 for Greece, 24 for Ireland, 25 for Croatia, 26 for Slovenia, 27 for Slovakia, 28 for Belarus, 29 for Estonia, 30 (vacant), 31 for Bosnia and Herzegovina, 32 for Latvia, 33 (vacant), 34 for Bulgaria, 35 (vacant), 36 for Lithuania, 37 for Turkey, 38 (vacant), 39 for Azerbaijan, 40 for The former Yugoslav Republic of Macedonia, 41 (vacant), 42 for the European Community (Approvals are granted by its Member States using their respective ECE symbol), 43 for Japan, 44 (vacant), 45 for Australia, 46 for Ukraine, 47 for South Africa and 48 for New Zealand. Subsequent numbers shall be assigned to other countries in the chronological order in which they ratify or accede to the Agreement Concerning the Adoption of Uniform Technical Prescriptions for Wheeled Vehicles, Equipment and Parts which can be Fitted and/or be Used on Wheeled Vehicles and the Conditions for Reciprocal Recognition of Approvals Granted on the Basis of these Prescriptions, and the numbers thus assigned shall be communicated by the Secretary-General of the United Nations to the Contracting Parties to the Agreement.

- 5.2. Vehicles, or cabs for vehicles, not exceeding 7 tonnes TPMM shall be subjected, at the manufacturer's choice, either to all the tests specified in annex 3 to this Regulation or only to tests A and B. [However, a vehicle type which has been approved according to Regulation No. 33 may be considered to have satisfied the requirements on frontal impact (test A).] One, two or three cabs, at the manufacture's choice, shall be used for this purpose.
- 5.3. Cabs for vehicles, exceeding 7 tonnes TPMM shall be subjected, at the manufacturer's choice, to test C specified in annex 3 to this regulation and to tests D, and E specified in annex 6 to this Regulation or only to tests D and E. One, two or three cabs, at the manufacturer's choice, shall be used for this purpose.
- 5.4. A vehicle type which meets the requirements of test D shall also be considered to meet the requirements for test A and a vehicle type meeting the requirements for test E shall also be considered to have met the requirements of B.
- 5.5. Survival space required after the test or tests A, B or C.
 - 5.5.1. After undergoing each of the tests referred to in paragraph 5.2. above, the cab of the vehicle shall exhibit a survival space allowing accommodation of the manikin defined in annex 3, appendix 2 on the seat, when the latter is in its median position, without contact between the manikin and non-resilient parts. To facilitate installation, the manikin may be inserted in dismantled form and assembled in the cab. For this purpose, the seat shall be adjusted to its most rearward position and the manikin completely assembled and so placed that its H point coincides with the R point. The seat shall then be moved forward to its median position for the assessment of the survival space.
 - 5.5.2. The space so defined shall be verified for every seat provided by the manufacturer.
 - 5.5.3. Survival space required after the test or tests D and E
 - 5.5.4. After undergoing each of the tests referred to in paragraph 5.3. above, the vehicle shall exhibit a survival space, as occupied by the manikin defined in annex 6, appendix 2 that has not been intruded and does not exhibit evidence of contact between the manikin and any non-resilient parts. Displacement of the limbs of the manikin is acceptable provided that the displacement is unlikely to have resulted in a fracture or other significant injury.
 - 5.5.5. Tests D and E shall be carried out for every seat provided by the manufacturer except that the test need not be repeated for any seat that when in its lowest and most reward position would not cause the manikin to be higher or further forward than at the time of test.
- 5.6. Other conditions
 - 5.6.1. During the tests A, B and C the components by which the cab is secured to the chassis frame may be distorted or broken, provided that the cab remains attached to the chassis frame. During the tests D and E the components by which the cab is secured to the

chassis frame may be distorted provided that the cab remains attached to the chassis frame

5.6.2. None of the doors shall open during the tests, but the doors shall not be required to open after testing.

5.7. Tests B and C need not be carried out if the manufacturer can show by calculations of the strength of the component parts of the cab or by other means that the roof or rear wall will not undergo deformation dangerous to the occupants (penetration into the survival space) if subjected to the conditions of tests B and C.

6. MODIFICATIONS AND EXTENSIONS OF APPROVAL OF THE VEHICLE TYPE

6.1. Every modification of the vehicle type shall be notified to the administration department which approved the vehicle type. That department may then either:

6.1.1. consider that the modifications made are unlikely to have an appreciable adverse effect, and that in any case the vehicle still meets the requirements; or

6.1.2. require a further test report from the technical service responsible for conducting the tests.

6.2. Confirmation or refusal of approval, specifying the alterations, shall be communicated by the procedure specified in paragraph 4.3. above to the Contracting Parties to the Agreement which apply this Regulation.

6.3. The competent authority issuing the extension of approval shall assign a series number for such an extension and inform thereof the other Parties to the 1958 Agreement applying this Regulation by means of a communication form conforming to the model in annex 1 to this Regulation.

7. CONFORMITY OF PRODUCTION

The conformity of production procedures shall comply with those set out in the Agreement, Appendix 2 (E/ECE/324-E/ECE/TRANS/505/Rev.2), with the following requirements:

7.1. Every vehicle bearing an approval mark as prescribed under this Regulation shall conform to the vehicle type approved as regards features capable of affecting the characteristics of the cab.

7.2. In order to verify conformity as prescribed in paragraph 7.1. above, serially-produced vehicles bearing the approval mark required by this Regulation may be subjected to random checks.

7.3. As a general rule, the checks aforesaid shall be confined to the taking of measurements. However, the vehicles shall if necessary be subjected to the tests described in annex 3 to this Regulation.

7.4. The authority which has granted type approval may at any time verify the conformity control methods applied in each production facility.

The manual frequency of these verifications shall be [one every two years].

8. PENALTIES FOR NON-CONFORMITY OF PRODUCTION

8.1. The approval granted in respect of a vehicle type pursuant to this Regulation may be withdrawn if the requirement laid down in paragraph 7.1. above is not complied with or if the cab fails to pass the checks prescribed in paragraphs 7.2. and 7.3. above.

8.2. If a Party to the Agreement which applies this Regulation withdraws an approval it has previously granted, it shall forthwith notify the other Contracting Parties applying this Regulation by means of a communication form conforming to the model in annex 1 to this Regulation.

9. PRODUCTION DEFINITELY DISCONTINUED

If the holder of the approval completely ceases to manufacture a vehicle type approved in accordance with this Regulation, he shall so inform the authority which granted the approval. Upon receiving the relevant communication that authority shall inform thereof the other Parties to the 1958 Agreement which apply this Regulation by means of a communication form conforming to the model in annex 1 to this Regulation.

10. TRANSITIONAL PROVISIONS

10.1. As from the official date of entry into force of the 03 series of amendments, no Contracting Party applying this Regulation shall refuse to grant ECE approval under this Regulation as amended by the 03 series of amendments.

10.2. As from _____ Contracting Parties applying this Regulation shall grant ECE approvals only if the requirements of this Regulation, as amended by the 03 series of amendments are satisfied.

10.3. As from _____ Contracting Parties applying this Regulation may refuse to recognize approvals which were not granted in accordance with the 03 series of amendments to this Regulation.

11. NAMES AND ADDRESSES OF TECHNICAL SERVICES CONDUCTING APPROVAL TESTS, AND OF ADMINISTRATIVE DEPARTMENTS

The Parties to the Agreement which apply this Regulation shall communicate to the Secretariat of the United Nations the names and addresses of the technical services conducting approval tests and of the administrative departments which grant approval and to which forms certifying approval or refusal or withdrawal of approval, issued in other countries, are to be sent.

Annex 1

COMMUNICATION

(maximum format: A4 (210 x 297 mm))

Issued by: Name of administration
.....
.....



Concerning 2/ APPROVAL GRANTED
APPROVAL EXTENDED
APPROVAL REFUSED
APPROVAL WITHDRAW
PRODUCTION DEFINITELY DISCONTINUED

of a vehicle type with regard to the protection of the occupants of the cab
of a commercial vehicle pursuant to Regulation No. 29.

Approval No..... Extension No:.....

1. Trade name or mark of the vehicle
2. Vehicle type
3. Manufacturer's name and address
4. If applicable, name and address of manufacturer's representative
5. Brief description of the cab's design and method of attachment
6. Vehicle submitted for approval on
7. Technical service responsible for conducting approval tests
8. Date of test report issued by that service
9. Number of test report issued by that service
10. Tests passed by cab: A / B / C / D / E/ 2/
11. Approval granted/extended/refused/withdrawn 2/
12. Position of approval mark on the vehicle
13. Place

14. Date
15. Signature

The list of documents deposited with the Administrative Service which has granted approval is annexed to this communication and may be obtained on request.

1/ Distinguishing number of the country which has granted/extended/refused/withdrawn approval (see approval provisions in the Regulation).

2/ Strike out what does not apply.

Annex 2

ARRANGEMENTS OF APPROVAL MARKS

Model A

(See paragraph 4.4. of this Regulation)

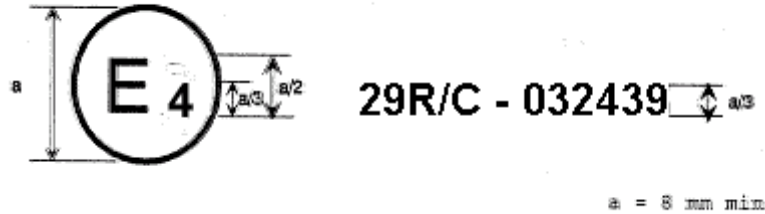

The above approval mark affixed to a vehicle shows the vehicle type concerned has with regard to the protection of the occupants of the cab of a commercial vehicle, been approved in the Netherlands (E 4), under the number 03249 and that the cab of the vehicle meets the requirements of test C. The first two digits of the approval number indicate the Regulation No. 29 already included the 03 series of amendments when the approval was given.

Model B

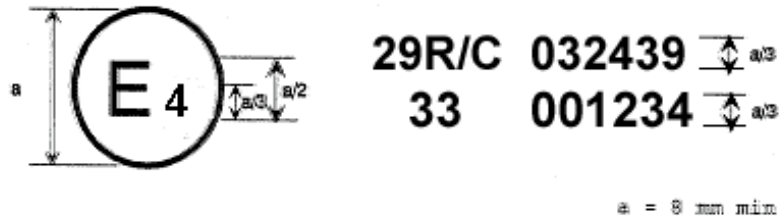

The above approval mark affixed to a vehicle shows that the vehicle type concerned has been approved in the Netherlands (E 4) pursuant to Regulations Nos. 29 and 33 ^{1/}. The cab of the vehicle meets the requirements of test C. The approval numbers indicate that on the dates on which these approvals were granted, Regulation No. 29 included the 03 series of amendments and Regulation No. 33 was in its original version.

^{1/} The later number is given as an example only

Annex 3

TEST PROCEDURE: TESTS A, B and C

1. Doors

Before the test the doors of the cab shall be closed but not locked.

2. Engine

For test A the engine, or a model equivalent thereto in mass, dimensions and mounting, shall be fitted to the vehicle.

3. Anchorage of the cab

For test A, the cab shall be mounted on a vehicle. For test B and C, the cab shall at the manufacturer's choice be mounted either on a vehicle or on a separate frame. The vehicle or frame shall be secured in the manner prescribed in appendix 1 to this annex.

4. Front impact test (test A)

4.1. Description of the impacting pendulum

4.1.1. The rotating assembly shall be of rigid construction and freely suspended. It is constituted of the impactor and two beams rigidly attached to it and spaced not less than 1,000 mm apart.

4.1.2. The impactor shall be made of steel and its mass shall be evenly distributed. Its striking face, rectangular and flat, shall be 2,500 mm wide and 800 mm high. Its edges shall be rounded to a radius of curvature of not less than 1.5 mm. On the reverse, it is allowed to attach the necessary balancing mass.

4.1.3. The beams shall be of "I" section with a web height of not less than 100 mm or shall be of a section having at least an equivalent moment of inertia. The distance between the geometric centre of the striking face and the axis of rotation shall be not less than $d = 3,500$ mm.

4.1.3.1. its striking face is in contact with the foremost part of the vehicle;

4.1.3.2. its centre of gravity is $50 \pm 5/0$ mm below the R-point of the driver's seat, and in no case more than 1,400 mm above the ground; and

4.1.3.3. its centre of gravity is in the median longitudinal plane of the vehicle.

The distance a between the centre of percussion of the pendulum and its axis of rotation is given by the following equation:

$$a = g \cdot (0.5T/\pi)^2 = 0.2485 \cdot T^2$$

where $g = 9.81 \text{ m/s}^2$ and $T =$ the swing period (i.e. time in seconds of one cycle of pendulum movement).

The reduced mass m_a in the centre of percussion of the pendulum is given by the following equation:

$$m_a = m.c/a$$

where:

$m =$ the actual total mass of the pendulum;

$a =$ the distance between the centre of percussion and the axis of rotation;

$c =$ the distance between the centre of gravity of the pendulum and its axis of rotation.

4.1.6. The reduced mass of the pendulum shall be $m_a = 1,500 \pm 250 \text{ kg}$.

4.1.7. The position of the centre of percussion shall comply with the condition

$$a = (0.995 \pm 0.005).d$$

relating to the position d of the geometric centre of the striking face.

4.1.8. With the impact velocity measured in the centre of percussion v_a , the actual impact energy of pendulum can be expressed as:

$$E = 0.5.m_a.v_a^2$$

4.2. The impactor shall be so positioned that in the vertical position:

4.2.1. its striking face is in contact with the foremost part of the vehicle;

4.2.2. the geometric centre of its striking face shall be $50 \pm 5/-0 \text{ mm}$ below the R point for the driver's seat until the lower edge of that face reaches its lowest allowed position closely over the front bumper connected directly to the frame of the vehicle; and

4.2.3. its centre of gravity is in the median longitudinal plane of the vehicle.

4.2.4. The impactor shall strike the cab at the front in the direction towards the rear of the cab. The direction of impact shall be horizontal and shall be parallel to the median longitudinal plane of the vehicle. The impact energy shall be 30 kJ for vehicles of a permissible maximum mass up to 7,000 kg. [and 45 kJ for vehicles for which the permissible maximum mass exceeds this value.]

5. Roof strength (test B)

The roof of the cab shall withstand a static load corresponding to the maximum mass authorised for the front axle or axles of the vehicle, subject to a maximum of 10 tonnes. This load shall be distributed uniformly over all the bearing members of the roof structure of the driver's cab or compartment by means of a suitable-shaped rigid former.

6. Rear-wall strength (test C)

The rear wall of the cab shall be capable of withstanding a static force equivalent to 2 kn. per tonne of permissible useful mass. This load shall be applied by means of a rigid barrier perpendicular to the longitudinal median axis of the vehicle, covering at least the whole of the cab rear wall situated above the chassis frame, and moving parallel to that axis.

Annex 3 - Appendix 1

INSTRUCTIONS FOR SECURING VEHICLES TO THE TEST BED

1. Frontal impact

Test A shall be applied to a cab mounted on the vehicle in the following way (see figure 1 below).

1.1. Anchoring chains or ropes

Each anchoring chain or rope shall be of steel and shall be capable of withstanding a tractive load of at least 10 tons.

1.2. Blocking of the chassis frame

The longitudinal member of the chassis frame shall be supported on wooden blocks across their full width and over a length of not less than 150 mm. The front edges of the blocks must not be situated forward of the rearmost point of the cab, nor rearward of the mid-point of the wheel base. At the manufacturer's request the chassis frame shall be set in the attitude it takes up when loaded.

1.3. Longitudinal attachment

Rearward movement of the chassis frame shall be limited by chains or ropes A attached to the front of the chassis frame symmetrically in relation to its longitudinal axis, the points of attachment being not less than 600 mm apart. The chains or ropes shall when tensioned form a downward angle of not more than 25° with the horizontal and their projection on a horizontal plane shall form an angle of not more than 10° with the longitudinal axis of the vehicle. The chains or ropes may cross one another.

1.4. Lateral attachment

Lateral movement shall be limited by chains or ropes B attached to the chassis frame symmetrically in relation to its longitudinal axis. The points of attachment to the chassis shall be not more than 5 m and not less than 3 m from the front of the vehicle. The chains or ropes shall when tensioned form a downward angle of not more than 20° with the horizontal and their projection on a horizontal plane shall form an angle of not less than 25° and not more than 45° with the longitudinal axis of the vehicle.

1.5. Tensioning of chains or ropes and rear attachment

The chain or rope C shall to begin with be placed under a load of approximately 100 kgf. All slack in the four chains or ropes A and B shall be taken up and chain or rope C shall be subjected to a tensile stress of not less than 1, 000 kgf. The angle of chain or rope C with the horizontal shall not exceed 15°. A vertical blocking force of not less than 50 kgf shall be applied at point D between the chassis frame and the ground.

1.6. Equivalent mounting

At the request of the manufacturer the test may be carried out with the cab mounted on a special frame, on condition that this method of mounting is shown to be equivalent to mounting on the vehicle.

2. Roof strength

2.1. Cab mounted on the vehicle

Measures shall be taken to ensure that the vehicle does not shift appreciably during the test. For this purpose the hand-brake shall be applied, a gear engaged and the front wheels wedged with chocks. Deformation of the various components of the suspension (springs, tyres, etc.) shall be eliminated by means of rigid members. Its striking face, rectangular and flat, shall be 2,500 mm wide and 800 mm high. Its edges shall be rounded to a radius of curvature of not less than 1.5 mm. On the reverse it is allowed to attach the necessary balancing mass.

2.2. Cab mounted on a frame

Measures shall be taken to ensure that the frame does not shift appreciably during the test.

3. Strength of rear wall

3.1. Cab mounted on the vehicle

Measures shall be taken to ensure that the vehicle does not shift appreciably during the test. For this purpose the hand-brake shall be applied, a gear engaged and the front wheels wedged with chocks.

3.2. Cab mounted on a frame

Measures shall be taken to ensure that the vehicle does not shift appreciably during the test.

Front impact test
Fig. 1
Cab mounted on the vehicle

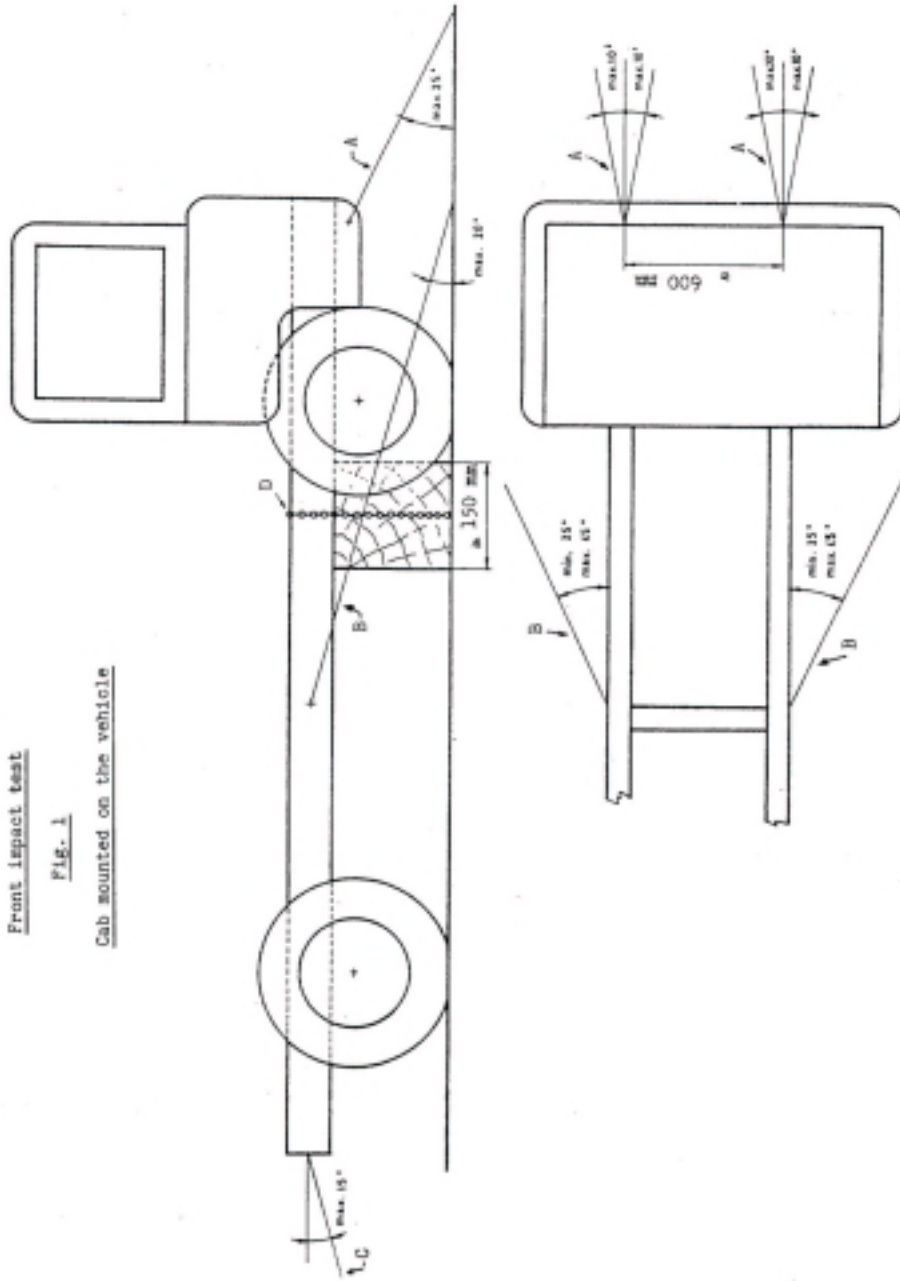

Annex 3 - Appendix 2

MANIKIN TO BE USED TO VERIFY THE SURVIVAL SPACE
(Fiftieth-percentile male body)

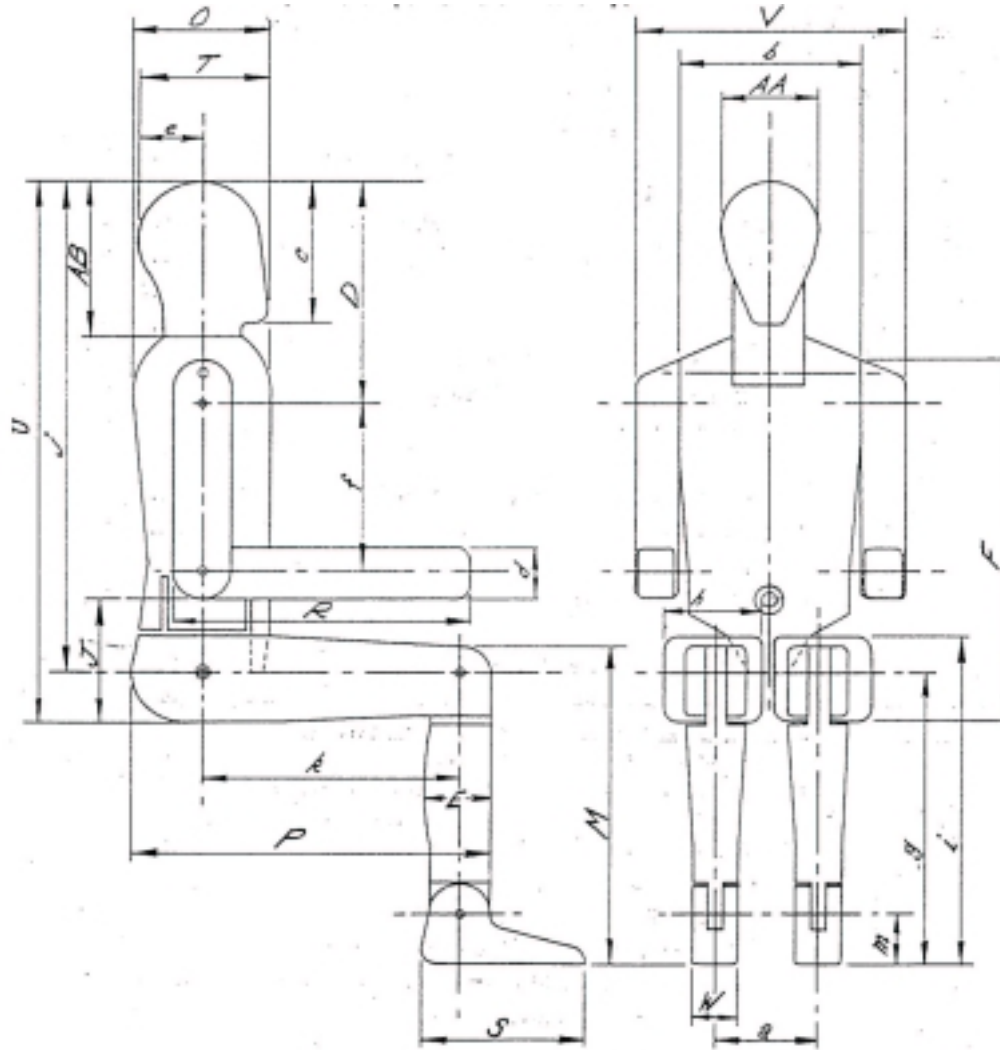

Material: Polystyrene; density 0.0169 g/cm³

Mass: 4.54 kg

Dimensions:	AA	Breadth of head	15.3	cm
	AB	Combined height of head and neck	24.4	cm
	D	Distance from top of head to shoulder pivot	35.9	cm
	E	Calf depth	10.6	cm
	F	Height from seat to top of shoulder	62.0	cm
	J	Height of elbow rest	21.0	cm
	M	Knee height	54.6	cm
	O	Chest depth	23.0	cm
	P	Distance from seat back to knee	59.5	cm
	R	Distance from elbow to fingertip	49.0	cm
	S	Length of foot	26.6	cm
	T	Length of head	21.1	cm
	U	Height from seat to top of head	90.0	cm
	V	Shoulder breadth	45.3	cm
	W	Breadth of foot	7.7	cm
	a	Distance between hip point centres	17.2	cm
	b	Chest breadth	30.5	cm
	c	Height of head and chin	22.1	cm
	d	Forearm thickness	9.4	cm
	e	Distance between vertical centreline of torso and rear of head	10.2	cm
	f	Distance between shoulder pivot and elbow pivot	28.3	cm
	g	Knee pivot, height from ground	50.5	cm
	h	Thigh breadth	16.5	cm
	i	Lap height (sitting)	56.5	cm
	j	Distance from top of head to 'H' point	81.9	cm
	k	Distance between hip pivot and knee pivot	42.6	cm
	m	Ankle pivot, height from ground	8.9	cm

Annex 4

PROCEDURE FOR DETERMINING THE "H" POINT AND THE ACTUAL TORSO ANGLE
FOR SEATING POSITIONS IN MOTOR VEHICLES

1. PURPOSE

The procedure described in this annex is used to establish the "H" point location and the actual torso angle for one or several seating positions in a motor vehicle and to verify the relationship of measured data to design specifications given by the vehicle manufacturer. 1/

2. DEFINITIONS

For the purposes of this annex:

2.1. "Reference data" means one or several of the following characteristics of a seating position:

2.1.1. the "H" point and the "R" point and their relationship,

2.1.2. the actual torso angle and the design torso angle and their relationship.

2.2. "Three dimensional "H" point machine" (3-D-H machine) means the device used for the determination of "H" points and actual torso angles. This device is described in Appendix 1 to this annex;

2.3. ""H" point" means the pivot centre of the torso and the thigh of the 3-D-H machine installed in the vehicle seat in accordance with paragraph 4 below. The "H" point is located in the centre of the centreline of the device which is between the "H" point sight buttons on either side of the 3-D-H machine. The "H" point corresponds theoretically to the "R" point (for tolerances see paragraph 3.2.2. below). Once determined in accordance with the procedure described in paragraph 4., the "H" point is considered fixed in relation to the seat-cushion structure and to move it when the seat is adjusted;

2.4. ""R" point or "seating references point"" means a design point defined by the vehicle manufacturer for each seating position and established by the vehicle manufacturer for each seating position and established with respect to the three-dimensional reference system;

2.5. "Torso-line" means the centreline of the probe of the 3-D-H machine with the probe in the fully rearward position;

2.6. "Actual torso angle" means the angle measured between a vertical line through the "H" point the torso line using the back angle quadrant on the 3-D-H machine. The actual torso angle corresponds theoretically to the design torso angle (for tolerances see paragraph 3.2.2. below):

- 2.7. "Design torso angle" means the angle measured between a vertical line through the "R" point and the torso line in a position which corresponds to the design position of the seat-back established by the vehicle manufacturer;
- 2.8. "Centreplane of occupant" (C/LO) means the median plane of the 3-D-H machine positioned in each designated seating position it is represented by the coordinate of the "H" point on the "Y" axis. For individual seats, the centreplane of the seat coincides with the centreplane of the occupant. For other seats, the centreplane of the occupant is specified by the manufacturer;
- 2.9. "Three-dimensional reference system" means a system as described in Appendix 2 to this annex;
- 2.10. "Fiducial marks" are physical points (holes, surfaces, marks or indentations) on the vehicle body as defined by the manufacturer;
- 2.11. "Vehicle measuring attitude" means the position of the vehicle as defined by the coordinates of fiducial marks in the three-dimensional reference system.

3. REQUIREMENTS

3.1. Data protection

For each seating position where reference data are required in order to demonstrate compliance with the provisions of the present Regulation, all or an appropriate selection of the following data shall be presented in the form indicated in appendix 3 to this annex:

- 3.1.1. the coordinates of the "R" point relative to the three-dimensional reference system;
- 3.1.2. the design torso angle;
- 3.1.3. all indications necessary to adjust the seat (if it is adjustable) to the measuring position set out in paragraph 4.3. below.
- 3.2. Relationship between measured data and design specifications
- 3.2.1. The coordinates of the "H" point and the value of the actual torso angle obtained by the procedure set out in paragraph 4. below shall be compared, respectively, with the coordinates of the "R" point and the value of the design torso angle indicated by the vehicle manufacturer.
- 3.2.2. The relative positions of the "R" point and the "H" point and the relationship between the design torso angle and the actual torso angle shall be considered satisfactory for the seating position in question if the "H" point, as defined by its coordinates, lies within a square of 50 mm side length with horizontal and vertical sides whose diagonals intersect at the "R" point, and if the actual torso angle is within 5° of the design torso angle.

- 3.2.3. If these conditions are met, the "R" point and the design torso angle, shall be used to demonstrate compliance with the provisions of this Regulation.
 - 3.2.4. If the "H" point or the actual torso angle does not satisfy the requirements of paragraph 3.2.2. above, the "H" point and the actual torso angle shall be determined twice more (three times in all). If the results of two of these three operations satisfy the requirements, the conditions of paragraph 3.2.2. above shall apply.
 - 3.2.5. If the results of at least two of the three operations described in paragraph 3.2.4. above do not satisfy the requirements of paragraph 3.2.2. above, or if the verification cannot take place because the vehicle manufacturer has failed to supply information regarding the position of the "R" point or regarding the design torso angle, the centroid of the three measured points or the average of the three measured angles shall be used and be regarded as applicable in all cases where the "R" point or the design torso angle is referred to in this Regulation.
4. PROCEDURE FOR "H" POINT AND ACTUAL TORSO ANGLE DETERMINATION
 - 4.1. The vehicle shall be preconditioned at the manufacturer's discretion, at a temperature of $20 \pm 10^{\circ}$ C to ensure that the seat material reached room temperature. If the seat to be checked has never been sat upon, a 70 to 80 kg person or device shall sit on the seat twice for one minute to flex the cushion and back. At the manufacturer's request, all seat assemblies shall remain unloaded for a minimum period of 30 min prior to installation of the 3-D-H machine.
 - 4.2. The vehicle shall be at the measuring attitude defined in paragraph 2.11. above.
 - 4.3. The seat, if it is adjustable, shall be adjusted first to the rearmost normal driving or riding position, as indicated by the vehicle manufacturer, taking into consideration only the longitudinal adjustment of the seat, excluding seat travel used for purposes other than normal driving or riding positions. Where other modes of seat adjustment exist (vertical, angular, seat-back, etc.) these will be adjusted to the position specified by the vehicle manufacturer. For suspension seats, the vertical position shall be rigidly fixed corresponding to a normal driving position as specified by the manufacturer.
 - 4.4. The area of the seating position contacted by the 3-D-H machine shall be covered by a muslin cotton, of sufficient size and appropriate texture, described as a plain cotton fabric having 18.9 threads per cm² and weighing 0.228 kg/m² or knotted or non-woven fabric having equivalent characteristics. If test is run on a seat outside the vehicle, the floor on which the seat is placed shall have the same essential characteristics 2/ as the floor of the vehicle on which the seat is intended to be used.
 - 4.5. Place the seat and back assembly of the 3-D-H machine so that the centreplane of the occupant (C/LO) coincides with the centreplane of the 3-D-H machine. At the manufacturer's request, the 3-D-H machine

may be moved inboard with respect to the C/LO if the 3-D-H machine is located so far outboard that the seat edge will not permit levelling of the 3-D-H machine.

4.6. Attach the foot and lower leg assemblies to the seat pan assembly, either individually or by using the T-bar and lower leg assembly. A line through the "H" point sight buttons shall be parallel to the ground and perpendicular to the longitudinal centreplane of the seat.

4.7. Adjust the feet and leg positions of the 3-D-H machine as follows:

4.7.1. Designated seating position: driver and outside front passenger

4.7.1.1. Both feet and leg assemblies shall be moved forward in such a way that the feet take up natural positions on the floor, between the operating pedals if necessary. Where possible the left foot shall be located approximately the same distance to the left of the centreplane of the 3-D-H machine as the right foot is to the right. The spirit level verifying the transverse orientation of the 3-D-H machine is brought to the horizontal by readjustment of the seat pan if necessary, or by adjusting the leg and foot assemblies towards the rear. The line passing through the "H" point sight buttons shall be maintained perpendicular to the longitudinal centreplane of the seat.

4.7.1.2. If the left leg cannot be kept parallel to the right leg and the left foot cannot be supported by the structure, move the left foot until it is supported. The alignment of the sight buttons shall be maintained.

4.7.2. Designated seating position: outboard rear

For rear seats or auxiliary seats, the legs are located as specified by the manufacturer. If the feet then rest on parts of the floor which are at different levels, the foot which first comes into contact with the front seat shall serve as a reference and the other foot shall be so arranged that the spirit level giving the transverse orientation of the seat of the device indicates the horizontal.

4.7.3. Other designated seating positions:

The general procedure indicated in paragraph 4.7.1. above shall be followed except that the feet shall be placed as specified by the vehicle manufacturer.

4.8. Apply lower leg and thigh weights and level the 3-D-H machine.

4.9. Tilt the back pan forward against the forward stop and draw the 3-D-H machine away from the seat-back using the T-bar. Reposition the 3-D-H machine on the seat by one of the following methods:

4.9.1. If the 3-D-H machine tends to slide rearwards, use the following procedure. Allow the 3-D-H machine to slide rearwards until a forward horizontal restraining load on the T-bar is no longer

required i.e. until the seat pan contacts the seat-back. If necessary, reposition the lower leg.

- 4.9.2. If the 3-D-H machine does not tend to slide rearward, use the following procedure. Slide the 3-D-H machine rearwards by applying a horizontal rearward load to the T-bar until the seat pan contacts the seat-back (see figure 2 of Appendix 1 to this annex).
- 4.10. Apply a 100 ± 10 N load to the back and pan assembly of the 3-D-H machine at the intersection of the hip angle quadrant and the T-bar housing. The direction of the load application shall be maintained along a line passing by the above intersection to a point just above the thigh bar housing (see figure 2 of Appendix 1 to this annex). Then carefully return the back pan to the seat back. Care must be exercised throughout the remainder of the procedure to prevent the 3-D-H machine from sliding forward.
- 4.11. Install the right and left buttock weights and then, alternately, the eight torso weights. Maintain the 3-D-H machine level.
- 4.12. Tilt the back pan forward to release the tension on the seat-back. Rock the 3-D-H machine from side to side through 10° arc (5° to each side of the vertical centreplane) for three complete cycles to release any accumulated friction between the 3-D-H machine and the seat.

During the rocking action, the T-bar of the 3-D-H machine may tend to diverge from the specified horizontal and vertical alignment. The T-bar must therefore be restrained by applying an appropriate lateral load during the rocking motions. Care shall be exercised in holding the T-bar and rocking the 3-D-H machine to ensure that no inadvertent exterior loads are applied in a vertical or fore and aft direction.

The feet of the 3-D-H machine are not to be restrained or held during this step. If the feet change position, they should be allowed to remain in that attitude for the moment.

Carefully return the back pan to the seat-back and check the two spirit levels for zero position. If any movement of the feet has occurred during the rocking operation of the 3-D-H machine, they must be repositioned as follows:

Alternatively, lift each foot off the floor the minimum necessary amount until no additional feet movement is obtained. During this lifting, the feet are to be free to rotate; and no forward or lateral loads are to be applied. When each foot is placed back in the down position, the heel is to be in contact with the structure designed for this.

Check the lateral spirit level for zero position; if necessary apply a lateral load to the top of the back pan sufficient to level the 3-D-H machine's seat pan on the seat.

- 4.13. Holding the T-bar to prevent the 3-D-H machine from sliding forward on the seat cushion, proceed as follows:
- (a) return the back pan to the seat-back;
 - (b) alternately apply and release a horizontal rearward load, not to exceed 25 N, to the back angle at a height approximately at the centre of the torso weights until the hip angle quadrant indicates that a stable position has been reached after load release. Care shall be exercised to ensure that no exterior downward or lateral loads are applied to the 3-D-H machine. If another level adjustment of the 3-D-H machine is necessary, rotate the back pan forward, re-level, and repeat the procedure from paragraph 4.12.
- 4.14. Take all measurements:
- 4.14.1. The coordinates of the "H" point are measured with respect to the three-dimensional reference system.
 - 4.14.2. The actual torso angle is read at the back angle quadrant of the 3-D-H machine with the probe in its fully rearward position.
- 4.15. If a re-run of the installation of the 3-D-H machine is desired, the seat assembly should remain unloaded for a minimum period of 30 min prior to the re-run. The 3-D-H machine should not be left loaded on the seat assembly longer than the time required to perform the test.
- 4.16. If the seats in the same row can be regarded as similar (bench seat, identical seats, etc.) only one "H" point and one "actual torso angle" shall be determined for each row of seats, the 3-D-H machine described in Appendix 1 to this annex being seated in a place regarded as representative for the row. This place shall be:
- 4.16.1. in the case of the front row, the driver's seat;
 - 4.16.2. in the case of the rear row or rows, an outer seat

1/ In any seating position other than front seats where the "H" point cannot be determined using the "Three dimensional 'H' point machine" or procedures, the "R" point indicated by the manufacturer may be taken as a reference at the discretion of the competent authority.

2/ Tilt angle, height difference with a seat mounting, surface texture, etc.

Annex 4 - Appendix 1

DESCRIPTION OF THE THREE-DIMENSIONAL "H" POINT MACHINE */

(3-D-H machine)

1. Back and seat pans

The back and seat pans are constructed of reinforced plastic and metal; they simulate the human torso and thigh and are mechanically hinged at the "H" point. A quadrant is fastened to the probe hinged at the "H" point to measure the actual torso angle. An adjustable thigh bar, attached to the seat pan, establishes the thigh centreline and serves as a baseline for the hip angle quadrant.

2. Body and leg elements

Lower leg segments are connected to the seat pan assembly at the T-bar joining the knees, which is a lateral extension of the adjustable thigh bar. Quadrants are incorporated in the lower leg segments to measure knee angles. Shoe and foot assemblies are calibrated to measure the foot angle. Two spirit levels orient the device in space. Body element weights are placed at the corresponding centres of gravity to provide seat penetration equivalent to a 76 kg male. All joints of the 3-D-H machine should be checked for free movement without encountering noticeable friction.

*/ For details of the construction of the 3-D-H machine refer to Society of Automobile Engineers (SAE), 400 Commonwealth Drive, Warrendale, Pennsylvania 15096, United States of America.

The machine corresponds to that described in ISO standard 6549-1980.

Annex 4 - Appendix 1

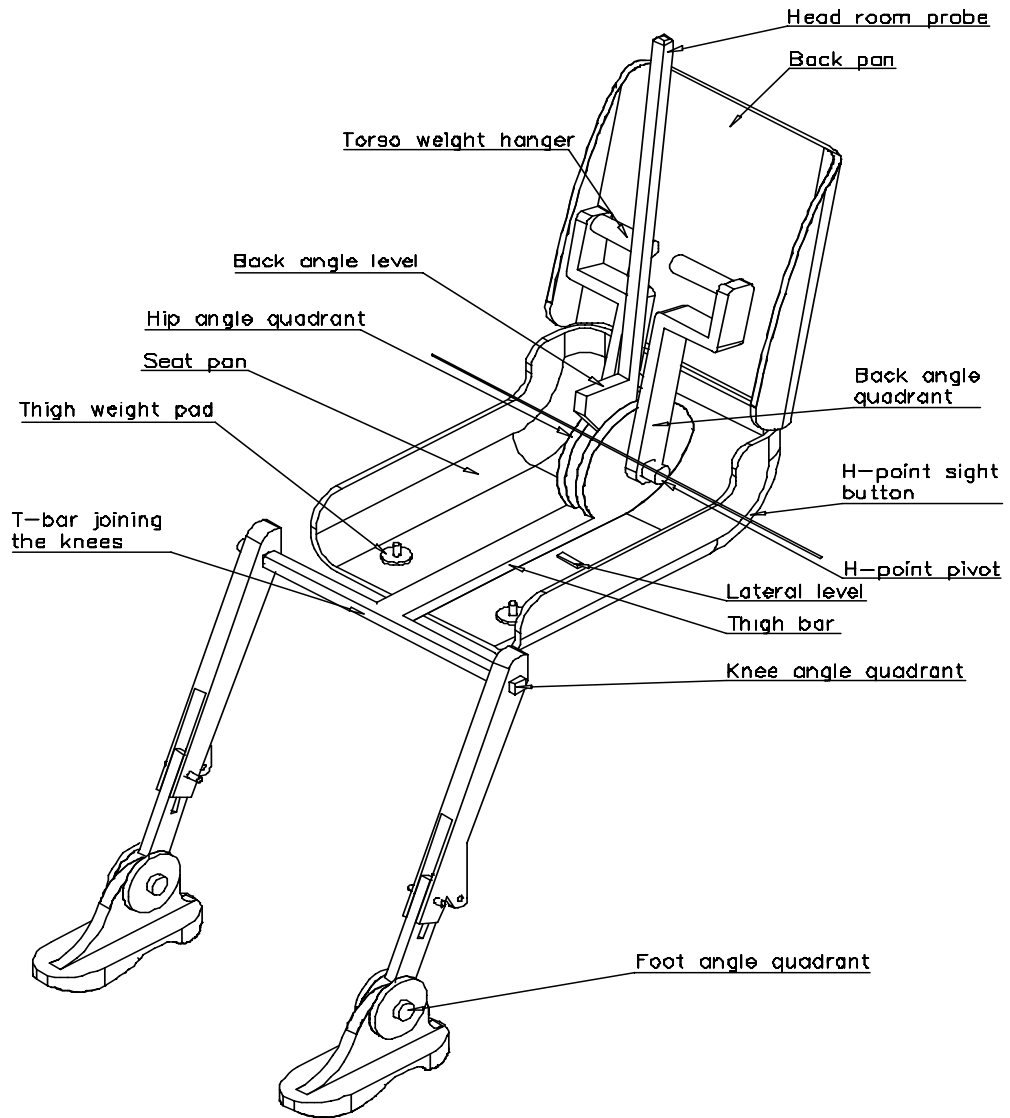

Figure 1: 3-D-H machine elements designation

Annex 4 - Appendix 1

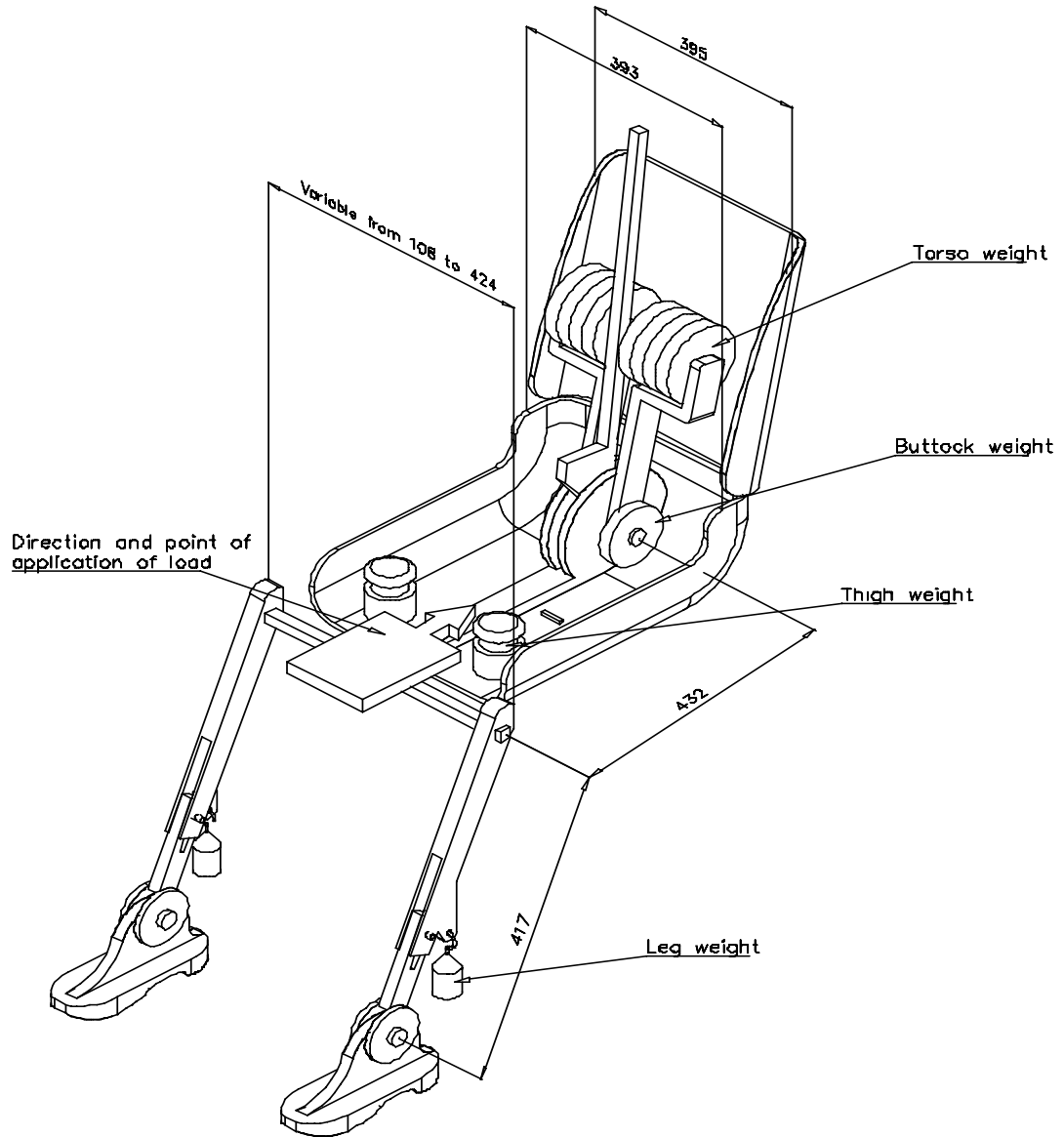

Figure 2: Dimensions of the 3-D-H machine elements and load distribution

Annex 4 - Appendix 2

THREE-DIMENSIONAL REFERENCE SYSTEM

1. The three-dimensional reference system is defined by three orthogonal planes established by the vehicle manufacturer (see figure)*/.
2. The vehicle measuring attitude is established by positioning the vehicle on the supporting surface such that the coordinates of the fiducial marks correspond to the values indicated by the manufacturer.
3. The coordinates of the "R" point and the "H" point are established in relation to the fiducial marks defined by the vehicle manufacturer.

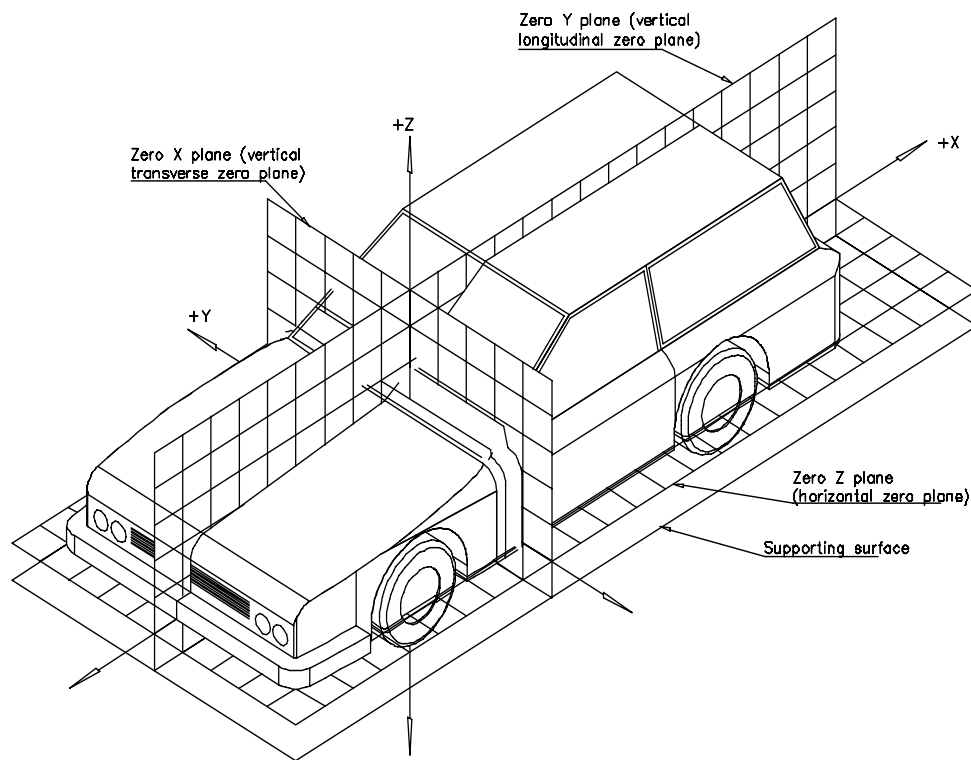

Figure Three dimensional reference system

*/ The reference system corresponds to ISO Standard 4130 - 1978.

Annex 5

REFERENCE DATA CONCERNING SEATING POSITIONS

1. Coding of reference data

Reference data are listed consecutively for each seating position. Seating positions are identified by a two-digit code. The first digit is an Arabic numeral and designates the row of seats, counting from the front of the rear of the vehicle. The second digit is a capital letter which designates the location of the seating position in a row, as viewed in the direction of forward motion of the vehicle; the following letters shall be used:

L = left

C = centre

R = right

2. Description of vehicle measuring attitude

2.1. Coordinates of fiducial marks

X

Y

Z

3. List of reference data

3.1. Seating position:

3.1.1. Coordinates of "R" point

X

Y

Z

3.1.2. Design torso angle:

3.1.3. Specifications for seat adjustment*

horizontal:

vertical:

angular:

torso angle:

Note: List reference data for further seating positions under 3.2., 3.3., etc.

Annex 6

TEST PROCEDURE FOR TESTS D AND E

1. Doors

Before the test the doors of the cab shall be closed but not locked.

2. Engine

For test D the engine, or a model equivalent to in mass, dimensions and mounting corresponding to the engine of smallest overall dimensions normally installed in vehicles that the cab being tested is used with, shall be fitted.

3. Anchorage of the cab

The cab shall be mounted on a separate frame. The frame shall be secured in the manner prescribed in Appendix 1 to this annex.

4. Front impact test (test D)

4.1. Description of the swing-bob

4.1.1. The swing-bob shall be made of steel and its mass shall be evenly distributed; its mass shall be not less than 1000 kgs and not more than 1500 kgs. It shall be of cylindrical construction $1000 \pm 10\text{mm}$ in length and $600 \pm 10\text{mm}$ in diameter Its edges shall be rounded to a radius of curvature of not less than 1.5 mm.

4.1.2. The swing-bob shall be of rigid construction. The swing-bob shall be freely suspended by two chains. The chains shall be not less than 3500 mm long from the axis of suspension and the geometric centre of the bob.

4.1.3. The swing-bob shall be so positioned that in the vertical position (see figure 2):

4.1.3.1. its striking face is in contact with the foremost part of the vehicle;

4.1.3.2. The longitudinal axis of the swing-bob shall lie in the transverse plane of the cab

4.1.4. The swing-bob shall strike the cab at the front in the direction towards the rear of the cab. The direction of impact shall be horizontal and shall be parallel to the median longitudinal plane of the vehicle. The impact energy shall be 40 kJ.

4.1.5. The foremost edge of the swing-bob shall strike the cab at a median point between

4.1.5.1. A horizontal plane level with the lowest part of the underside of the drivers floor between:

- 4.1.5.2. A transverse plane passing through the centre of the most forward seat mounting point and a transverse plane passing through the centre of the pivot of the service brake pedal and:
- 4.1.5.3. A horizontal plane level with the lowest part of the lower edge of the windscreen aperture.
 - 4.1.5.3.1. If the windscreen is stepped this shall be the longest edge or if an equal split the upper edge.
- 4.1.6. The outermost edge of the swing-bob shall lie between two parallel vertical planes 30mm apart, the inner one of which is parallel to the mean longitudinal plane and tangential to the outermost part of the drivers door not including any fitted projections such as, but not limited to, door handles, mirrors and trim.
- 5. Roof strength (test E)
 - 5.1. The cab shall be tilted to an angle of 25 degrees about its longitudinal axis so that the drivers side is uppermost (see figure three).
 - 5.2. The roof of the cab shall withstand a static load of 2.7 x the unladen weight of the front axle, or axles, of any vehicle to which it may be fitted, subject to a maximum load of 10 tonnes.
 - 5.3. The load shall be applied by a suitably shaped rigid platen the underside of which shall be evenly and uniformly covered in grease.

Figure 2
Front impact test. Test D

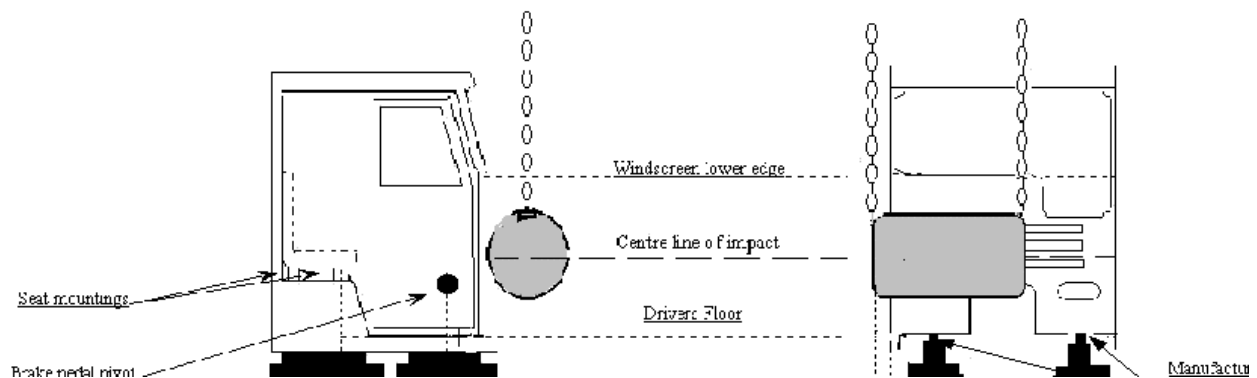
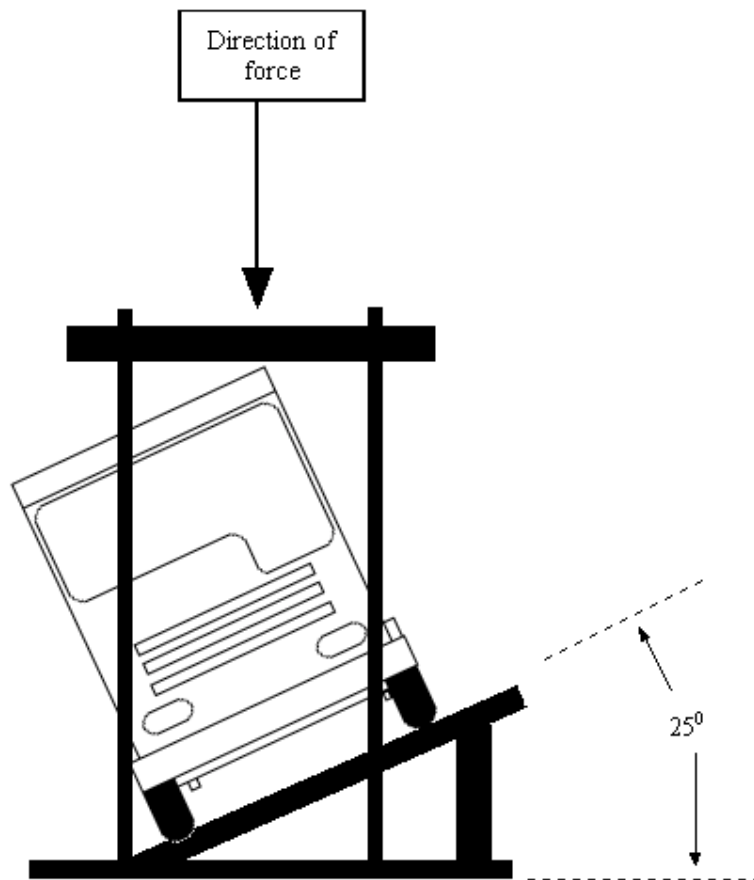

Figure 3

Roof crush test. Test E



INSTRUCTIONS FOR SECURING CABS TO THE TEST BED

1. Anchorage of the cab
 - 1.1. The cab shall be mounted on the frame using only the cabs normal mountings, mounting points and fasteners. This may include any cab-locking device or any other component fitted as standard between the cab and the vehicle chassis at the manufacturers request.
 - 1.2. For test E It may be necessary to provide additional lateral support to the mountings to avoid excessive displacement during the test.
-

Annex 6 - Appendix 2

MANIKIN TO BE USED TO VERIFY THE SURVIVAL SPACE:

(Ninety-five - percentile male body)

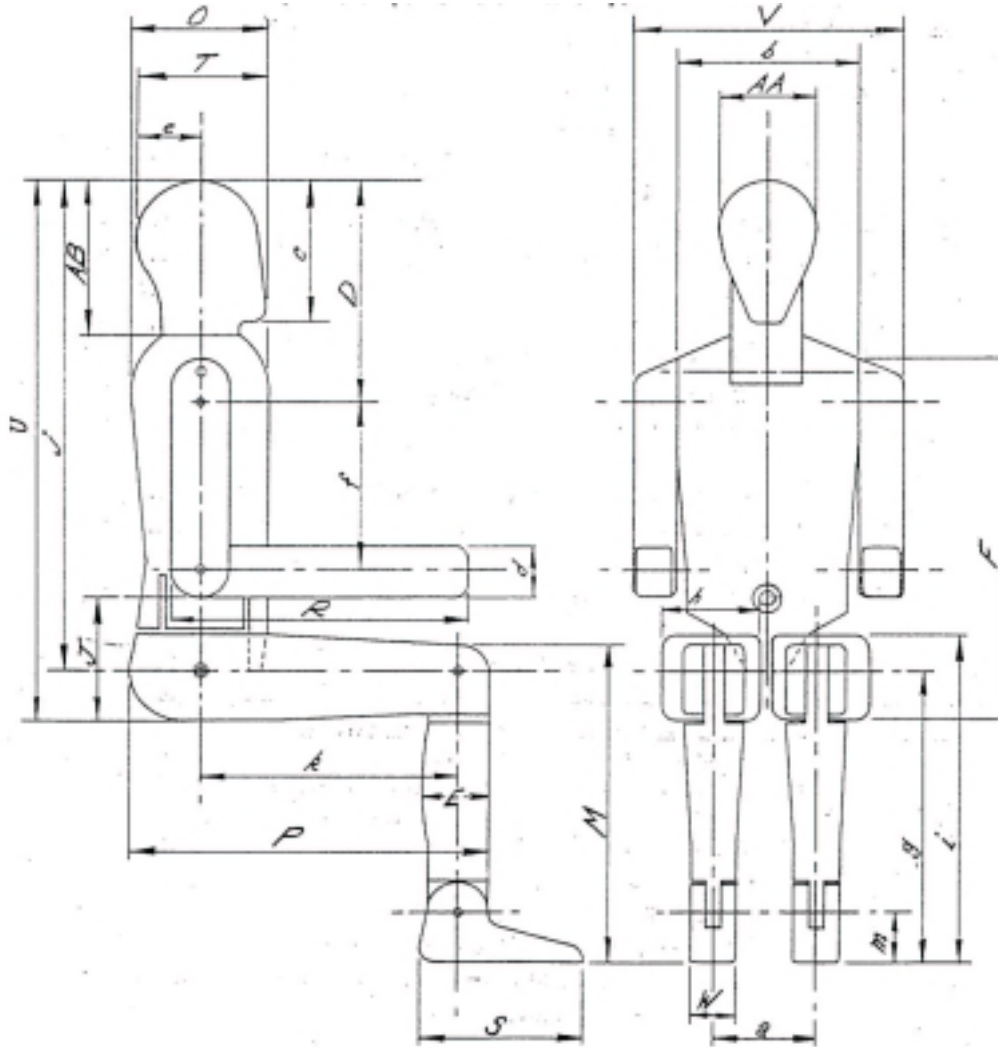

Annex 6 - Appendix 2

Dimensions:	AA	Breadth of head	15.8	cm
	AB	Combined height of head and neck	28.6	cm
	D	Distance from top of head to shoulder pivot	36.3	cm
	E	<u>Calf depth</u>	12.3	cm
	F	Height from seat to top of shoulder	63.6	cm
	J	Height of elbow rest	26.9	cm
	M	Knee height	65.0	cm
	O	Chest depth	29.2	cm
	P	Distance from seat back to knee	63.5	cm
	R	Distance from elbow to fingertip	51.6	cm
	S	Length of foot	37.1	cm
	T	Length of head	21.4	cm
	U	Height from seat to top of head	96.7	cm
	V	Shoulder breadth	49.7	cm
	W	Breadth of foot	12.2	cm
	a	Distance between hip point centres	21.6	cm
	b	Chest breadth	33.9	cm
	c	Height of head and chin	22.9	cm
	d	Forearm thickness	10.4	cm
	e	Distance between vertical centreline of torso and rear of head	12.2	cm
	f	Distance between shoulder pivot and elbow pivot	28.5	cm
	g	Knee pivot, height from ground	56.6	cm
	h	Thigh breadth	18.7	cm
	i	Lap height (sitting)	66.7	cm
	j	Distance from top of head to 'H' point	86.9	cm
	k	Distance between hip pivot and knee pivot	44.0	cm
	m	Ankle pivot, height from ground	10.7	cm

Annex 7

PROCEDURE FOR POSITIONING OF THE MANIKIN

1. Seating position
 - 1.1. The seat, if adjustable, shall be adjusted so that it is:
 - 1.1.1. In its lowest position
 - 1.1.2. Is as close as possible to, but not exceeding, a point in the horizontal plane, 100mm forward of its rearmost position.
 - 1.1.3. In all circumstances when considering any seat adjustment it is only the limit of adjustment for normal driving or riding positions that should be considered and should not include adjustment provided for any other purpose.
 - 1.2. suspension seats

the vertical position shall be rigidly fixed corresponding to a normal driving position as specified by the manufacturer commensurate with the size of the manikin used.
2. Steering wheel position
 - 2.1. The steering wheel, if it is adjustable, in any plane or arc, shall be adjusted to its highest and most forward position.
 - 2.2. In all circumstances when considering steering wheel adjustment it is only the limit of adjustment for normal driving that should be considered and should not include adjustment provided for any other purpose.
3. Positioning of the manikin
 - 3.1. A manikin of the same dimensions and as a Hybrid III 95 percentile male dummy shall be positioned in the drivers seat in the following manner:
 - 3.1.1. Centrally on the seat as far back as is possible in a normal sitting position and so the centre plane of the seat and of the manikin lie in the same vertical plane.
 - 3.1.2. This shall be achieved by adjusting the seat back or by the use suitable padding between the seat and the manikin or a combination of both.
 - 3.1.3. The manikin shall maintain an upright posture.
 - 3.1.4. The torso shall be securely fastened to the seat back with sticky tape or other suitable means.
 - 3.1.5. The feet of the manikin shall be positioned flat on the floor between the operating pedals in as natural position as possible and taped in place.
 - 3.1.6. The feet and legs shall, as far as is practicable, be kept parallel to each other.
 - 3.1.7. The hands of the manikin shall be placed on the steering wheel at the ten-to-two position and taped in place.

3.1.8. The hands and arms shall, as far as is practicable, be kept parallel with each other.

* * *

B. JUSTIFICATION

Introduction

A number of concerns have been raised about the suitability of Regulation No. 29 in its current form. These concerns fall into two areas, the suitability of the Regulation for light goods vehicles and those with integral load and cab area (vans) and the effectiveness of the existing test procedure, for vehicles over 7 tonnes of Gross Vehicle Permissible Mass, to ensure sufficient strength of the cab in an accident.

This proposal draws together formal and informal proposals from the Czech Republic, Italy, Russian Federation and the United Kingdom. The proposal is presented as a complete revised text of the Regulation. It has been presented in this way to improve the readability of the proposals. Also by combining most of the current proposals into one document it will allow them to be discussed as one item.

The individual proposals do at times conflict or overlap with one another. Where this occurs these are presented as options.

Re. to para. 1.,

This has been presented as a series of options as there are various suggestions to limit the scope to exclude vehicles less than 1,500 kg, 2,500kg, and 3,500 kg.

For information the original scope of this regulation was for vehicles over 7,000 kg only.

Re. to para. 5.2.,

The reference to Regulation No. 33 is in square brackets because if the scope is changed to exclude the smaller vehicles it will no longer be relevant.

Re. to para. 5.3.,

This requires tests D and E which replace tests A and B for vehicles over 7 tonnes and keeps test C as optional.

Re. to para. 5.4.,

If a vehicle meets the test requirements for over 7 tonnes this would be acceptable for those less than 7 tonnes.

Re. to paras. 5.5. and 5.6.,

The creation of two new paragraphs 5.3. and 5.4. means that the existing paragraphs 5.3. and 5.4. have been renumbered 5.5. and 5.6. respectively.

Re. to annex 3 para. 4.4.2.,

The original proposal also included an impact energy of 45 kJ for vehicles of more than 7000 kJ. However a different test for these heavier vehicles is also proposed and is dealt with later in the text.

Re. to annex 3 para 4.1.7.,

The coincidence of the centre of percussion with the geometric centre of the striking face, as demanded in paragraph 4.1.7. of annex 3, was derived from the CSN EN 10045-2 of November 1992: Charpy impact test. CSN EN is the Czech standard complying with the relevant EN standard.

Re. to annex 3 para. 4.2.4.,

The proposed text should more precisely present the conditions for the definition of the pendulum physical parameters for test A and bring them nearer the level of the published text incorporated in annex 4 Regulation No. 21 (03 series of amendments) and Regulation No. 32 in its original form.

Re. to annex 3 para. 6.,

The proposed amendment should remove the uncertainty in the case of the expression "the load" - load of 200 kgf = describes force (unit being Newton), tonne = describes mass (unit being kg). Useful load in tonnes = means mass (unit being kg, t).

Re. to annex 6 para. 4.1.6.,

The proposal to change the shape of the swing-bob (or impactor) is a direct result of research carried out by Cranfield Impact Centre (CIC). This concluded that the cylindrical shape of the swing-bob; the positioning of it, essentially mid-point between the windscreen lower edge and the drivers floor and, offset to one side replicated the effects of real world accidents much better than the existing test. As well as an improvement in the survival space to reduce fatalities it will also reduce the very significant number of lower limb injuries that occur in frontal impacts.

Re. to annex 6 para. 5.3.,

Again this change comes from research carried out by CIC and is more representative of rollover accidents than the existing test.
