

**THE PROBLEM OF HIGH-DECKER COACHES IN THE STANDARD
ROLLOVER TEST**
(Presented by Hungary)

1. Precedents.

- 1.1. On the 80th Meeting of GRSG Hungary raised the problem of the geometrically limited deformation of HD coaches in the standard rollover test (Informal doc. No.9.) GRSG agreed to extend the mandate of the ad-hoc expert group (AHEG) and asked AHEG to discuss this subject looking for a solution (TRANS/WP29/GRSG/59.para.25)
- 1.2. AHEG discussed the problem on its Brussels meeting where Hungary presented the problem. The decision was delayed to the next AHEG meeting, which was held in Frankfurt. UK presented a paper (AHEG-20) in which they expressed, that it was not a requirement to assure the same type of deformation for any kind of buses and they did not see the reason to modify the test bench geometry. The majority of AHEG agreed with the UK opinion. Hungary reserved the right to turn once more to GRSG in this subject (See Informal doc. No.2. on the 82nd Meeting of GRSG, para.13)

2. Geometrically limited deformation of the superstructure

- 2.1. In the case of a HD coach, tested according to the standard rollover test, if its superstructure has a four plastic hinges (PH) deformation mechanism (where the PH-s are located close to the cantrails and waistrails), the structural deformation stops, when the waistrails also touches the ground (See Fig.1.) As the results of the dynamic mass load “F” the bus slips away on the concrete surface of the ditch. The possible distortion of the superstructure may be characterised by the angle “ ω ”, depending on total height (H) of the coach.
- 2.2. In the case of the 4 PH-s deformation mechanism, which is very frequent in the existing bus constructions, the maximum acceptable distortion of the superstructure (when the window pillars just touch the survival space) may be characterised by the angle “ ν ”, depending on residual space geometry in the passenger compartment.
- 2.3. If $\omega < \nu$ that means: the distortion of the superstructure in a standard rollover test will be stopped because of the geometrical configuration of the test bench, even in the case of a weak superstructure, too.

3. The problem of the standard rollover test.

- 3.1. The consequence of the geometrically limited deformation is, that in the case of HD coaches, the standard rollover test can not separate the weak superstructure from the strong one. There is no meaning of the approval procedure, because every HD coach will be approved, independently from its strength.
- 3.2. According to their height (H) the buses may be ranged into three groups:
 - a) $H < 3,1$ m The standard rollover test is appropriate, the approval is correct
 - b) $3,1$ m $< H < 3,4$ m This is a “dark” range, in which different geometrical parameters (shape of the body, height of the waistrail related to the floor under the seats, floor height related to the ground, etc.) decide whether the positive test result is due to the strength of the superstructure or to the limited deformation.
 - c) $H > 3,4$ m The standard rollover test is not adequate.

4. Test evidences

During the AHEG meetings a lot of full scale rollover tests, body section rollover tests as well as computer simulation of these dynamic tests have been presented, in which the phenomenon of the limited deformation, the slipping away of the bus could be observed.

5. The origin of the test bench used in the standard rollover test

5.1. In the '70s there was a long discussion about the standard rollover test. Three different test methods have been tried out and discussed:

- Hungarian method (rolling down on a slope)
- UK method (lateral speed and deceleration, rolling into a ditch)
- Combined Hungarian-UK method (the existing approval test)

5.2. After the test method was agreed, long discussion was going on (in the early '80s) about the depth of the ditch:

- Hungarian proposal: 1000 mm
- UK and French proposal: 600 mm
- Swedish proposal: more than 1000 mm (They have made tests with a ditch depth of 1000 mm and 1400 mm)

After 2-3 years discussion: 800 mm has been accepted

5.3. This compromise does not relate to any

- a) accident statistics
- b) real road situation
- c) road construction practice or standard
- d) strong physical argument

5.4. Considering wide range of different bus constructions: low floor buses, HD coaches, traditional buses, midi buses (all belonging to Reg.36.) using the standard rollover test, the following main mechanical characteristics are different for the different bus construction:

- the impact force on the cantrail (both the direction and magnitude)
- the kinetic energy of the bus as an input data
- the relative kinetic energy (related to the mass)
- the structurally absorbed energy (both absolute and relative)
- the deformation possibility (limited or unlimited)

5.5. Summarising these facts, there is now logical reason to be stuck to the existing test bench if we want to eliminate the problem of limited deformation.

6. Hungary's position

6.1. Having a well established suspicion that the existing standard rollover test is not appropriate for the higher buses (HD coaches), this approval test method can not separate the strong superstructure from the weak one, GRSG as the component international expert group, or WP29 as the authorised decision making body is responsible for avoiding future catastrophes and tragedies, to make the necessary steps.

6.2 Hungary does not want to fight alone in this subjects. If GRSG and WP29 has the opinion that nothing to do, Hungary takes notice of that.

6.3. If GRSG and/or WP29 accepts that something has to be done to solve this problem, the possible steps could be:

- to finalise the modification Reg.66 without solving this problem
- to study the possible ways to avoid the limited deformation and to find the easiest, smallest change in the existing standard rollover test
- to combine this solution with the EU demand to extend Reg.66 to the small buses to (which belong to Reg.52.) and modifying Reg.66. accordingly.

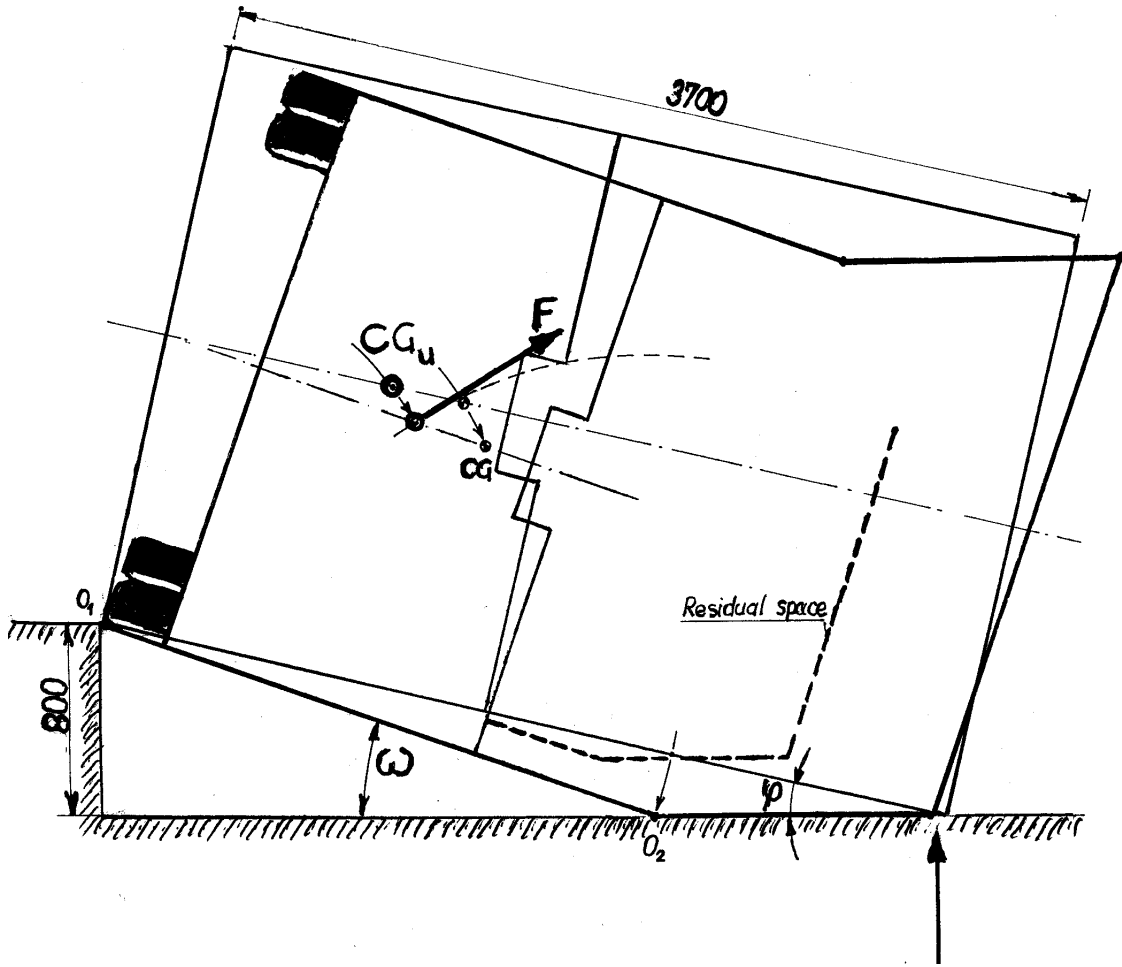

Fig.1. Deformation stops when the waistrail touches the ground (O_2)

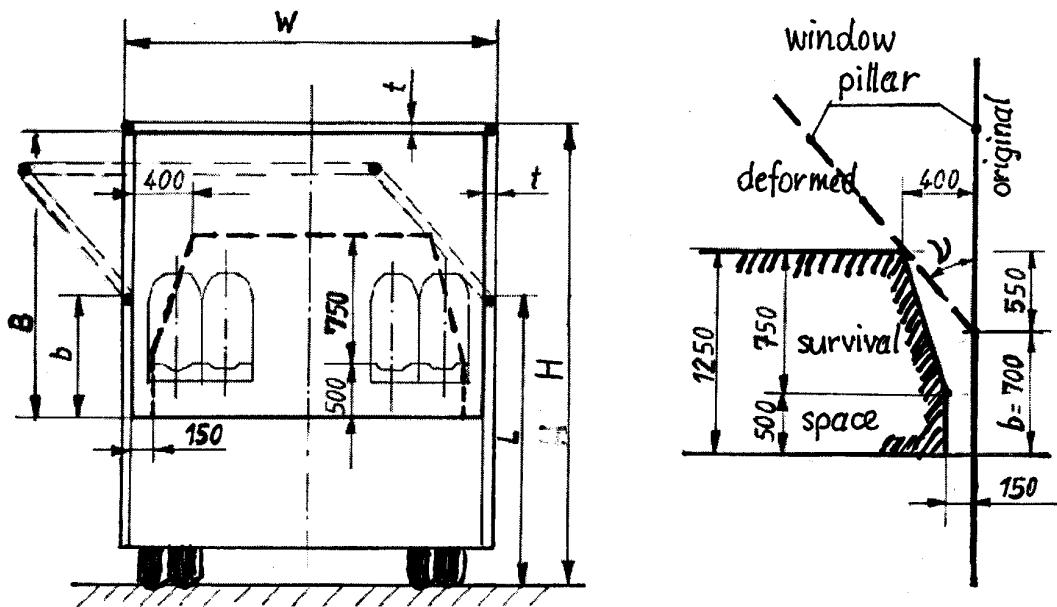

Fig.2. The acceptable limit of structural deformation